

MODEL: T1H3 Helicopter Tug



Contents

1. Components	3
1-1. <i>Components in the Box (1)</i>	3
1-2. <i>Components in the Box (2)</i>	4
1-3. <i>Components in the Box (3)</i>	5
1-4. <i>Components in the Box (4)</i>	6
1-5. <i>Tug Components (1)</i>	7
1-6. <i>Tug Components (2)</i>	8
1-7. <i>Radio Components</i>	9
1-8. <i>Charger Components</i>	10
1-9. <i>Spare Parts Kit</i>	11
1-10. <i>Spare Parts: Track Tools</i>	12
2. Quick Guide	14
2-1. <i>Air Bag</i>	14
2-2. <i>Auxiliary Wheels and Lifter Pole</i>	15
3. Tug Assembly	16
3-1 <i>Front End Assembly</i>	16
3-2 <i>Back End Assembly</i>	22
4. Tug Operation	27
4-1. <i>Radio Operation</i>	27
4-2. <i>Operating the Tug</i>	28
4-3. <i>Adjusting the Width of the T1H3 Tug</i>	30
4-4. <i>Loading the T1H3 Under the Helicopter Skids</i>	31
4-5. <i>Moving the helicopter with the T1H3 tug</i>	37
4-6. <i>Unloading the helicopter from the T1H3 tug</i>	38
5. Tug Care	39
5-1. <i>Adjusting the Track Tension</i>	39
5-2. <i>Charging the Tug</i>	41
5-3. <i>Charging the Transmitter</i>	42
5-4. <i>Replacing Radio Batteries</i>	43
6. Troubleshooting	45
7. Warranty	49

1. Components

1-1. Components in the Box (1)

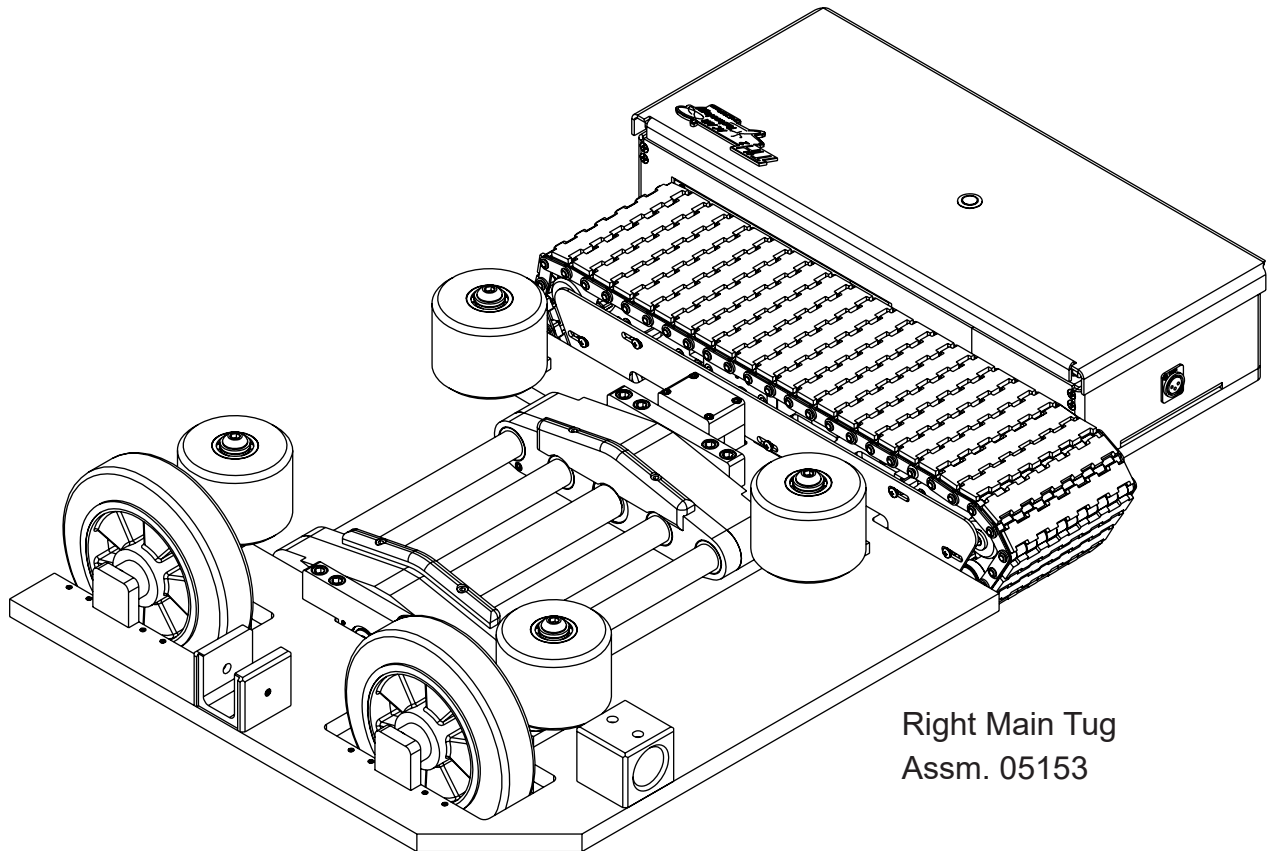

Right Main Tug
Assm. 05153

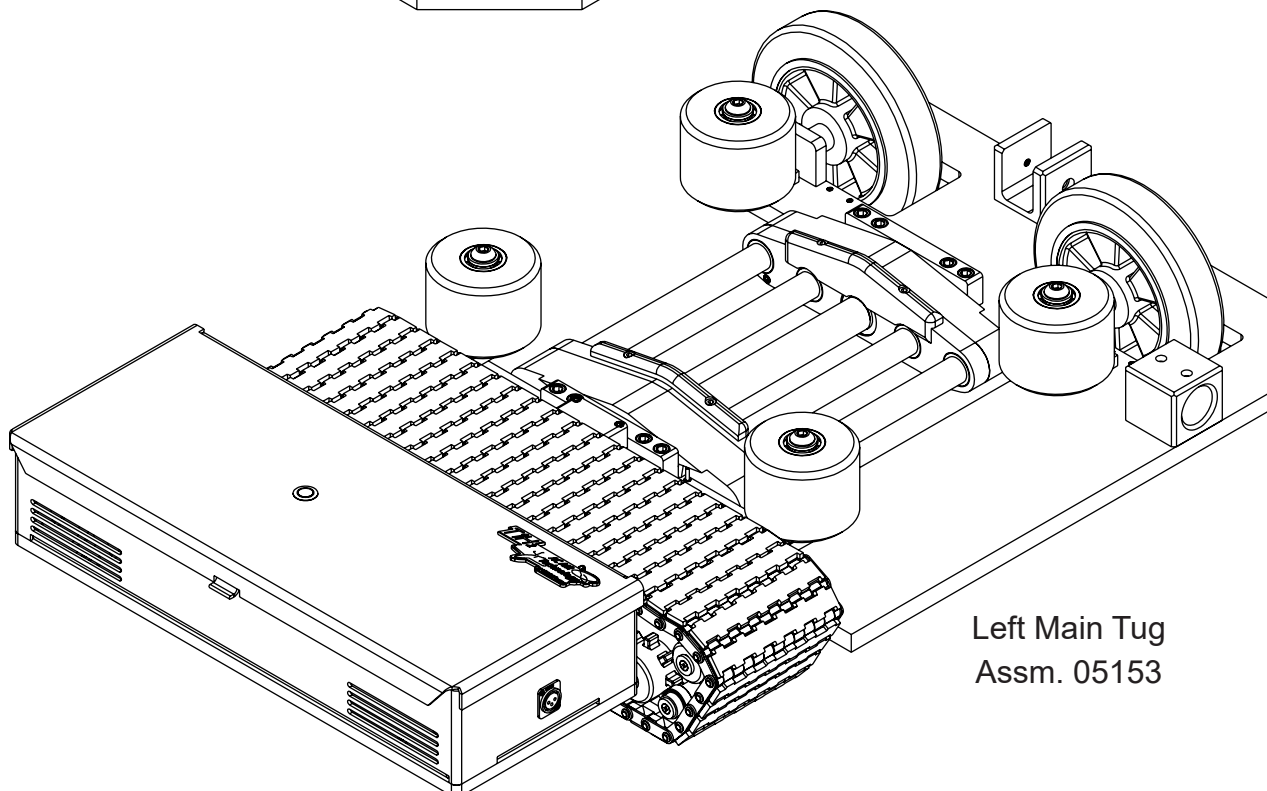

Left Main Tug
Assm. 05153

1-2. Components in the Box (2)

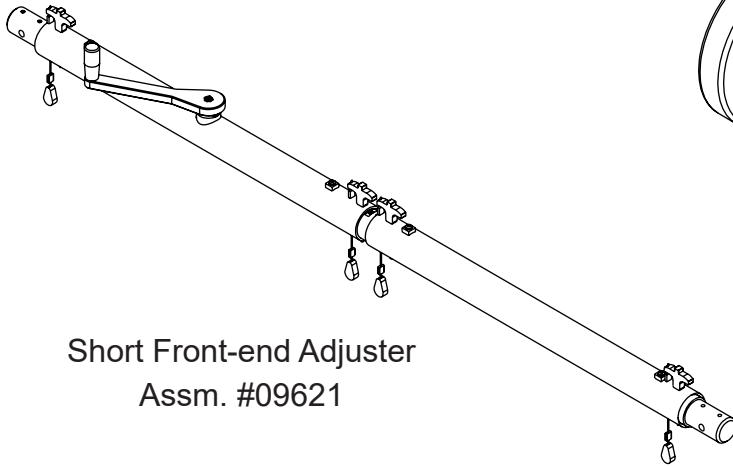

Short Front-end Adjuster
Assm. #09621

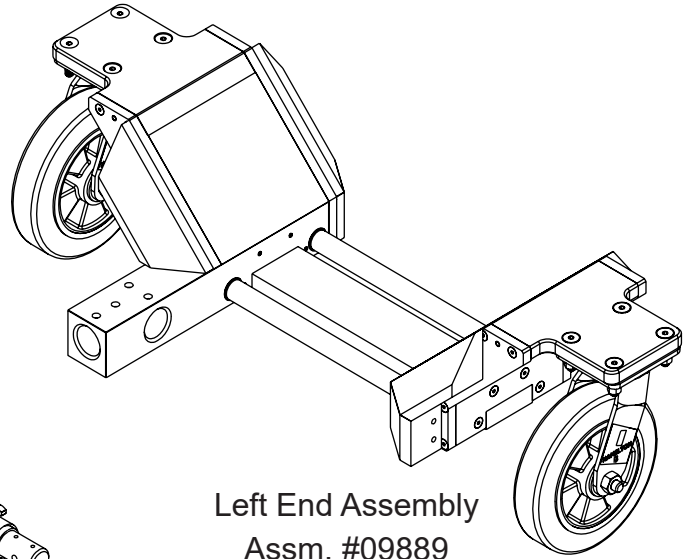

Left End Assembly
Assm. #09889

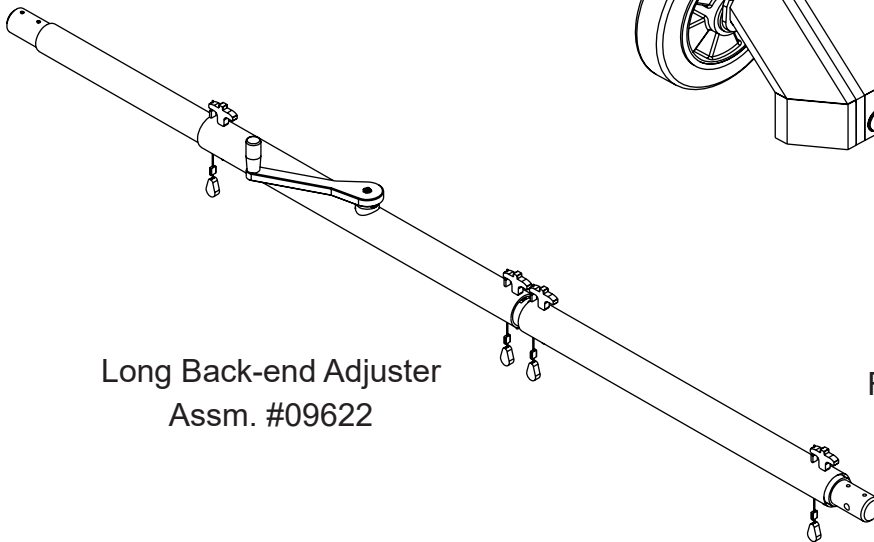

Long Back-end Adjuster
Assm. #09622

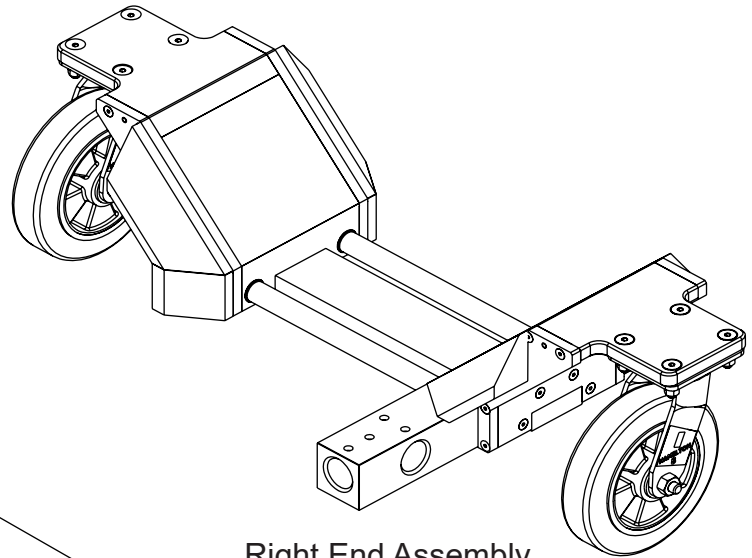

Right End Assembly
Assm. #09993

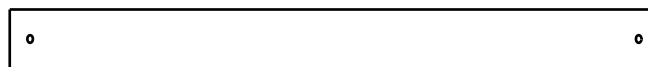

(2X) Frame Side Support
Part #02617

1-3. Components in the Box (3)

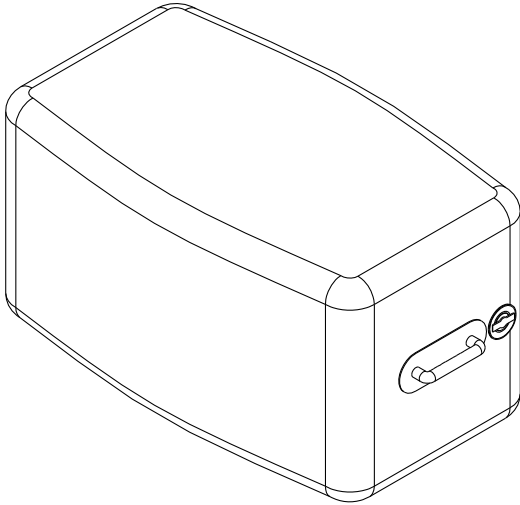

Air Bag
Part #95623

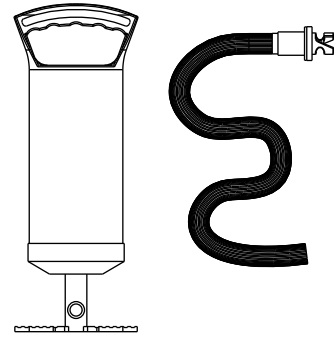

Hand Pump and Hose
Assm. #02532

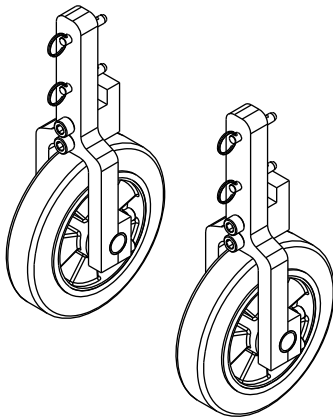

Auxiliary Wheels
Assm. #02532

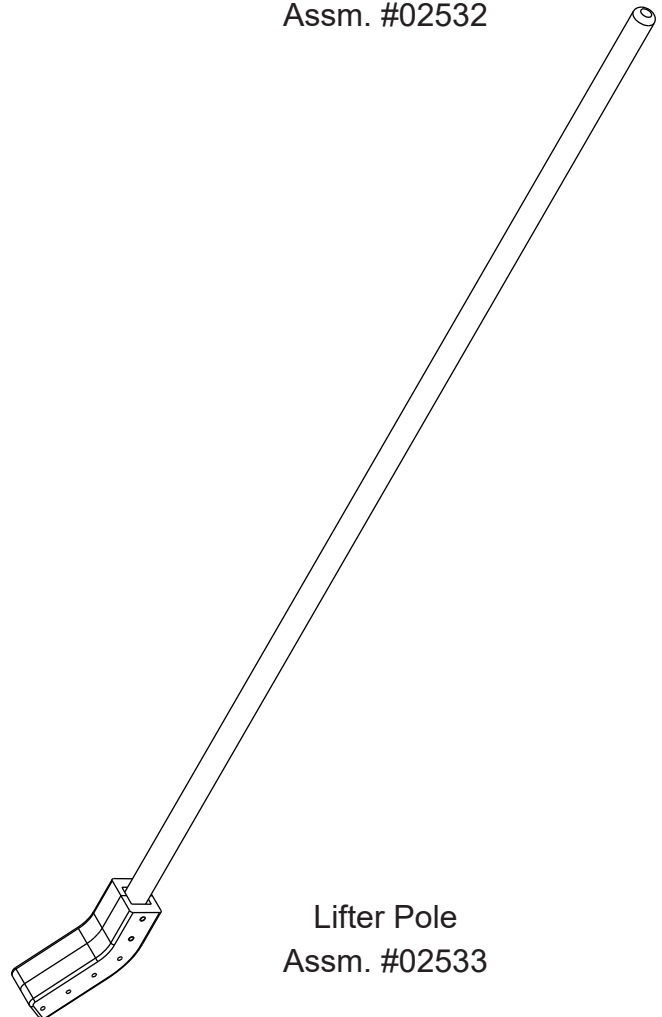

Lifter Pole
Assm. #02533

1-4. Components in the Box (4)

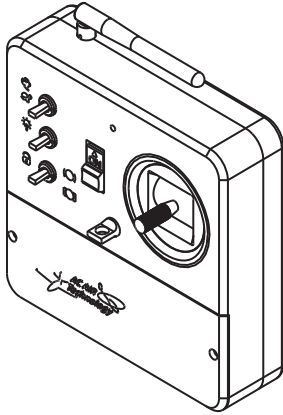

Radio Transmitter
Part #02629

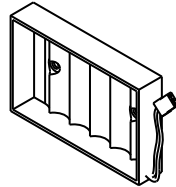

Battery Tray
Part #95087

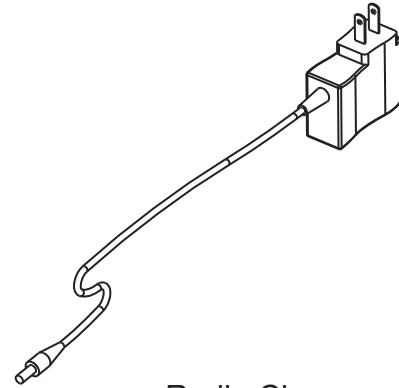

Radio Charger
Part #95102

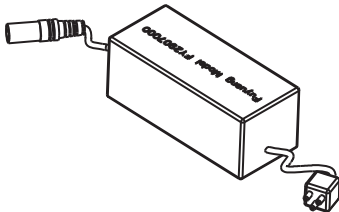

(2X) Tug Charger
Part #95394

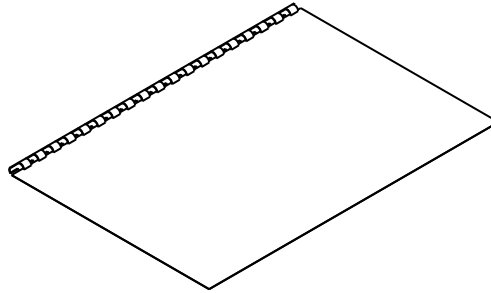

Owners Manual
Part #95679

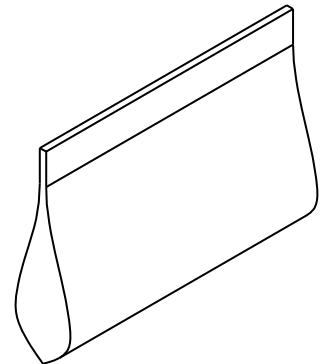

(2X) Spare Parts Bag
Part #09551

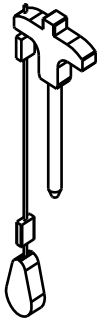

(4X) T-Handle
Part #95545

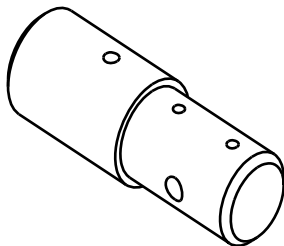

(4X) T1H3 Frame Insert
Part #24244

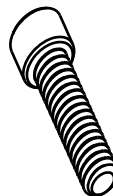

(12X) Socket Head
Part #95117

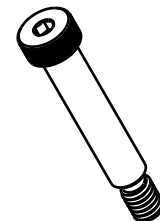

(2X) Shoulder Bolt
Part #95669

1-5. Tug Components (1)

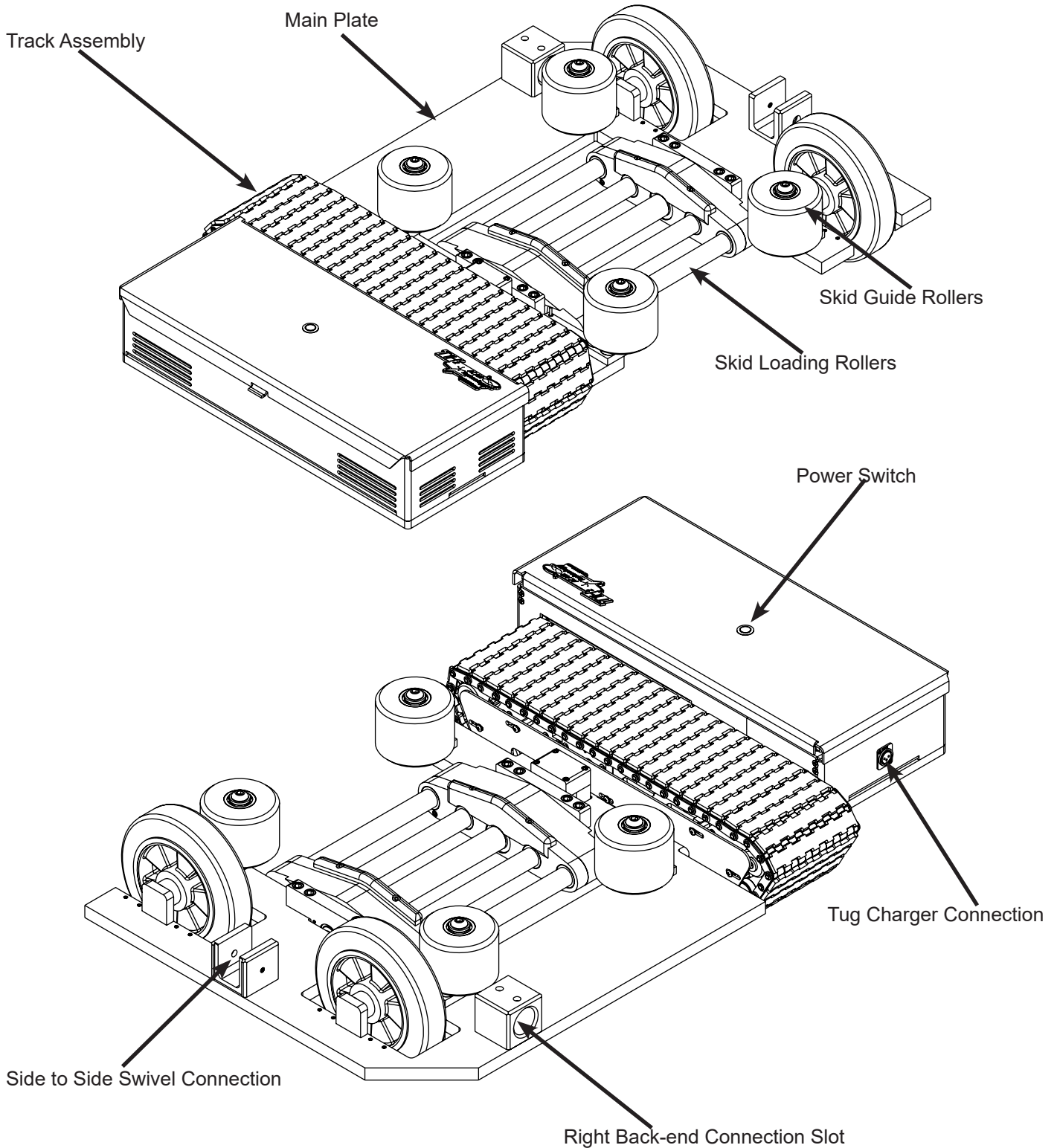

*Note Left Main Tug is an Identical Mirrored Component

1-6. Tug Components (2)

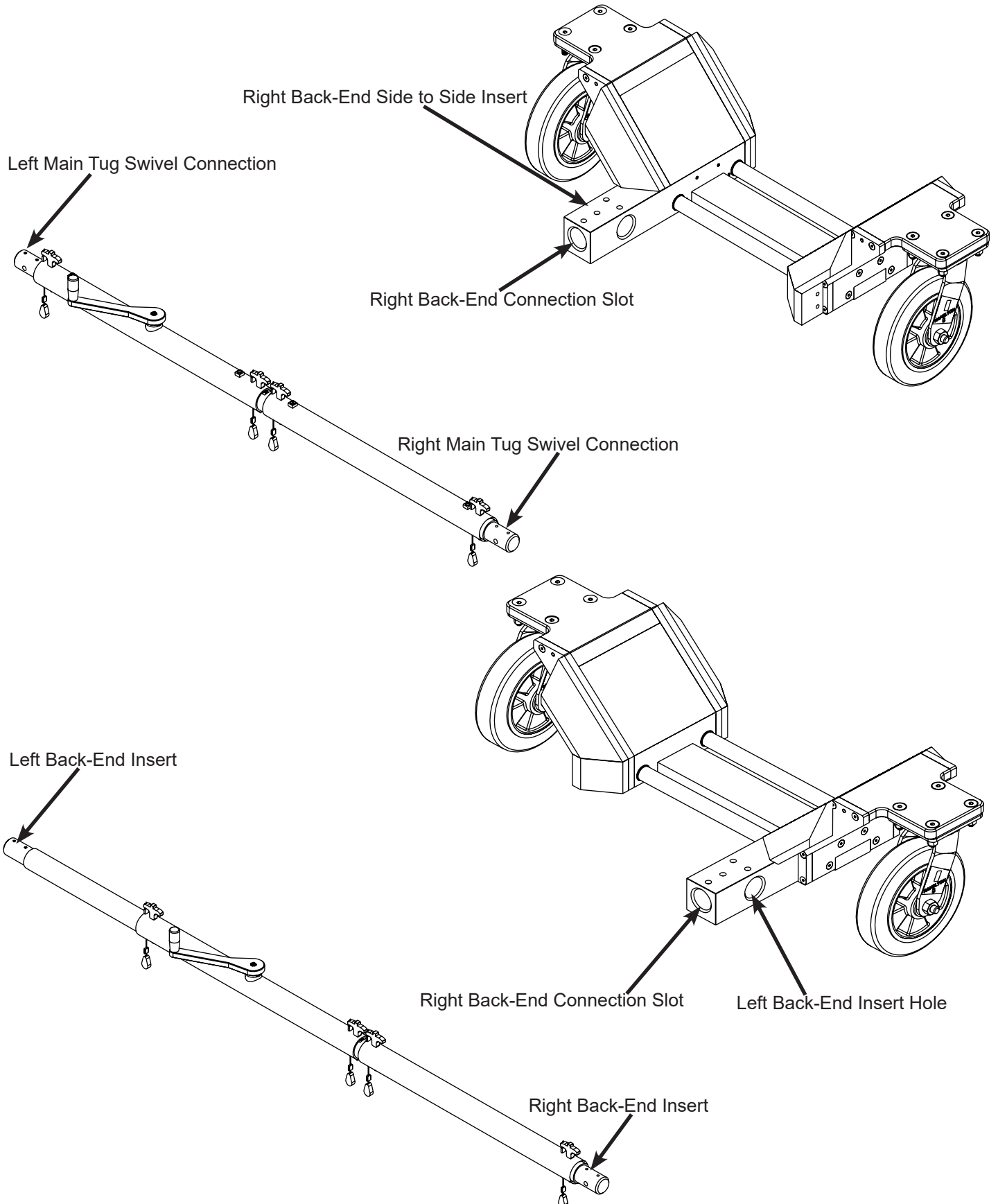

1-7. Radio Components

Radio Controller

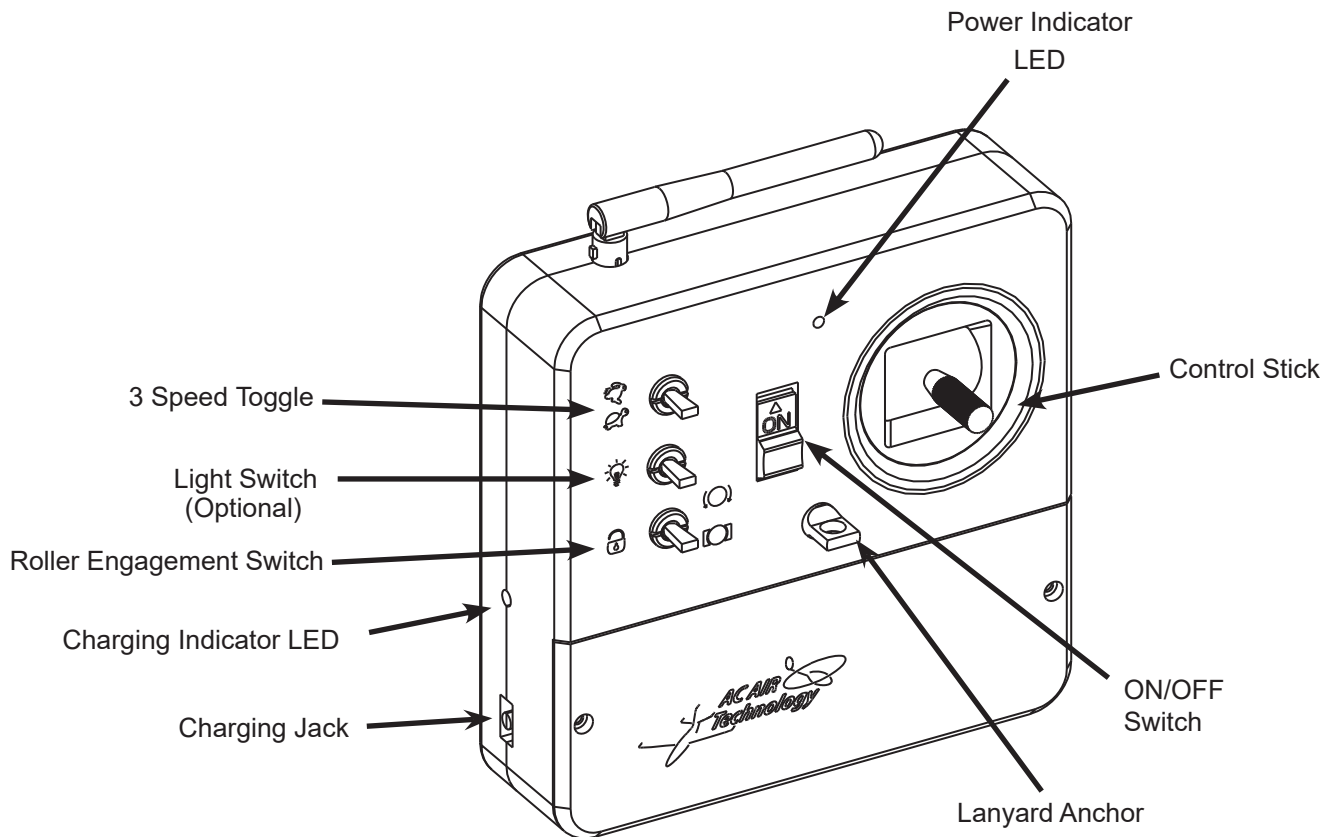

Warning: The control stick on the remote is very sensitive and will cause the tug to move if it is moved accidentally. When not using the remote it is recommended that the power switch is turned OFF.

Note: If the remote is not used for more than a couple minutes it will start beeping as a indicator that it is still in the ON position. This is not an indicator of a low battery.

1-8. Charger Components

Tug Charger (2 Included)

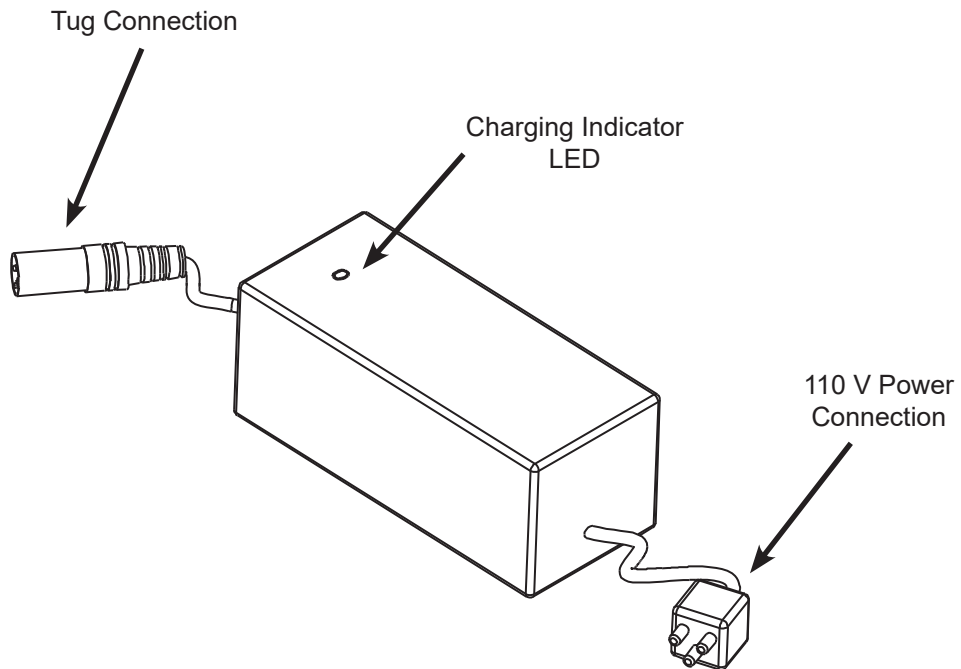

Radio Charger

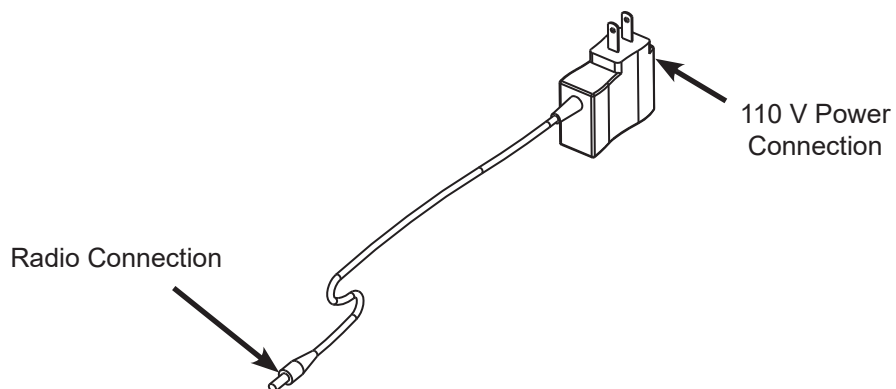

1-9. Spare Parts Kit

- **Spare Track Parts**

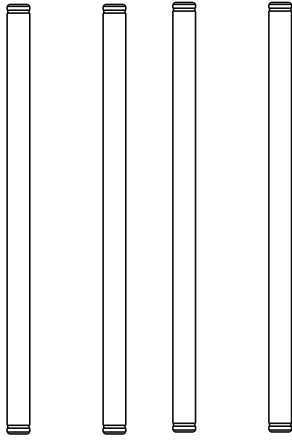

Pins

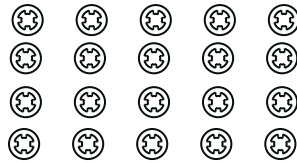

Rotoclips

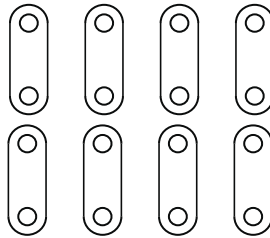

Links

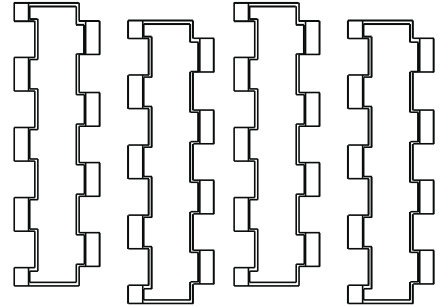

Treads

- **Track Install Tools**

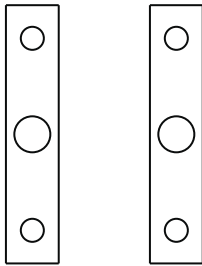

Track Pin Tools

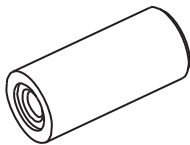

Retainer Clip Tool

- **Spare Track Parts**

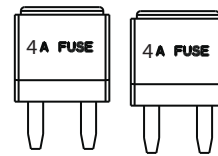

4 Amp Replacement Light Fuse

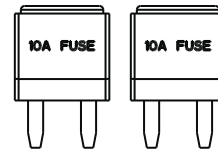

4 Amp Replacement Light Fuse

1-10. Spare Parts: Track Tools

The Track Tools are used to assist in the installation of new tracks.

This section is intended to show how the tools are used only. A detailed instruction guide is provided when purchasing new tracks. Refer to that instruction guide when installing new tracks.

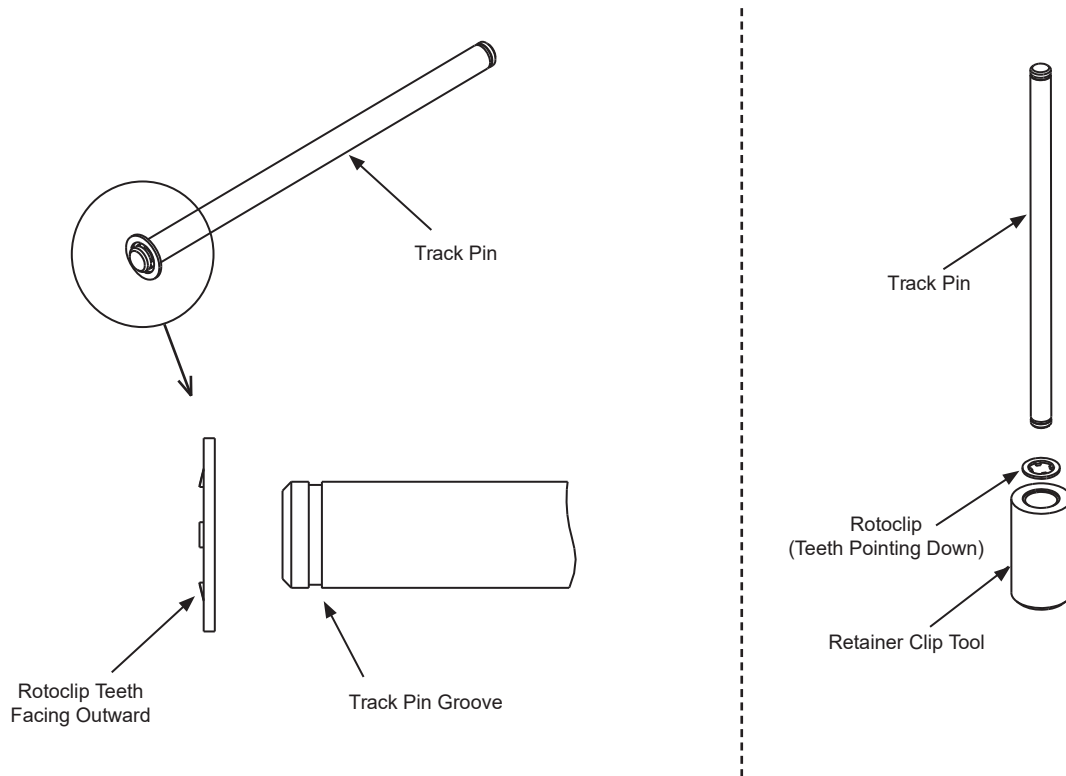

When Rotoclip is properly installed in the track pin groove it should rotate freely inside of the groove.

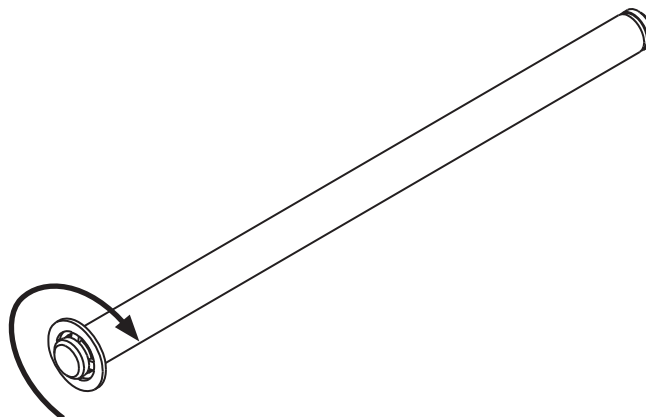

The Track Pin Tools are used to assist in the installation of new tracks when the tracks are too tight making it difficult to align the pin holes.

Insert the Track Pin Tools on the inside and outside adjacent pins to the missing pin hole. Note: You will need to hold these in place by hand.

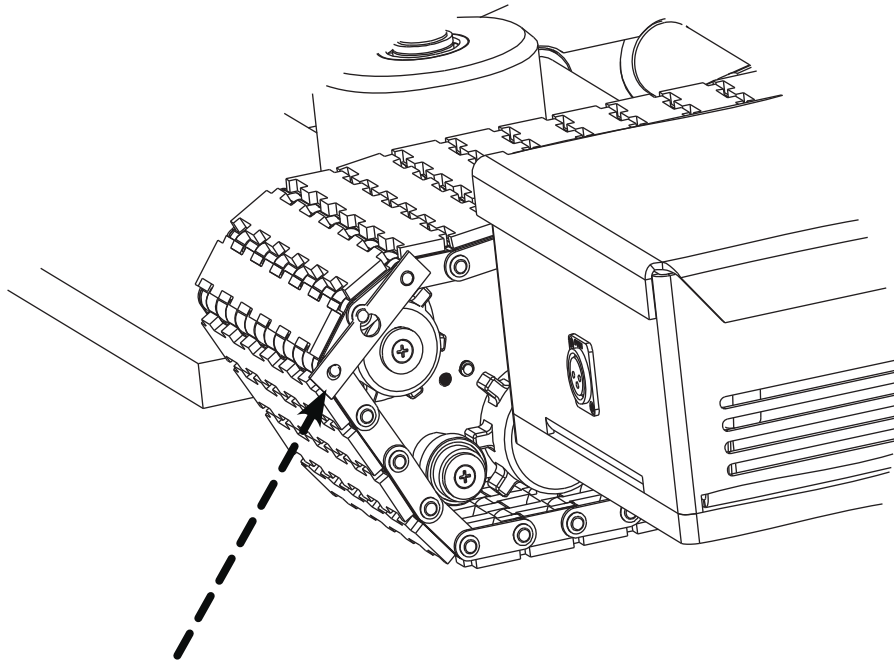

2. Quick Guide

2-1. Air Bag

1

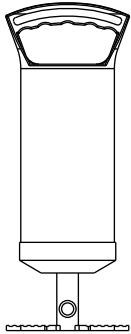

Hand Pump

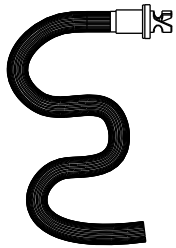

Hose

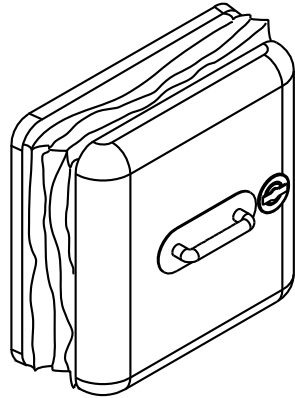

Air Bag

2

Inflate the Air Bag to 50-60% capacity

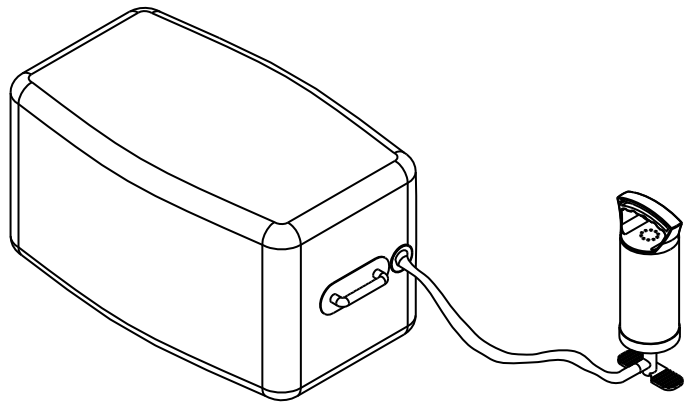

3 Place the Air Bag centered underneath the tail of the helicopter as shown

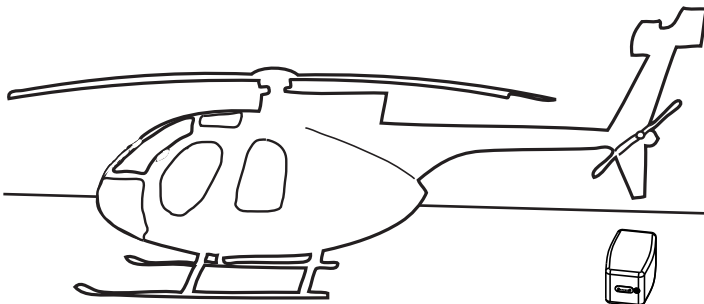

4 As the tug approaches the helicopter's center of gravity the tail will pivot down and rest on the air bag, protecting the tail from hitting the ground

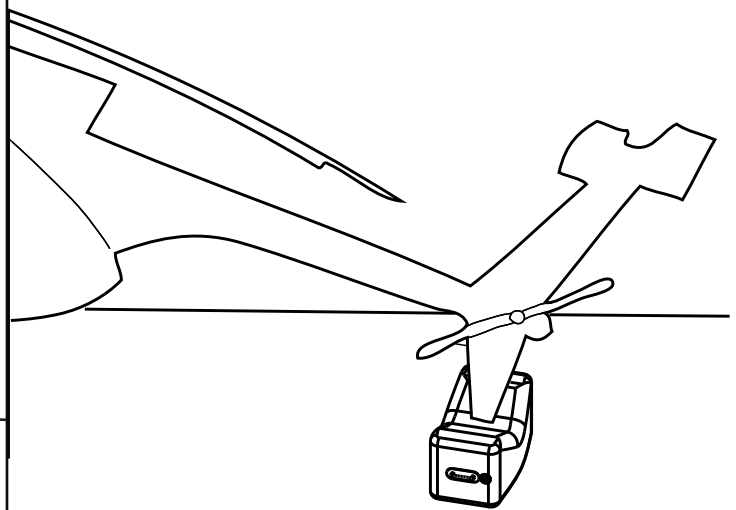

2-2. Aux. Wheels and Lifter Pole

1 If one track loses power, the auxiliary wheels can be installed to temporarily get the failed track off the ground and the helicopter off of the tug.

Auxiliary Wheels

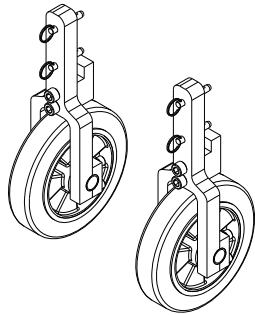

Lifer Pole

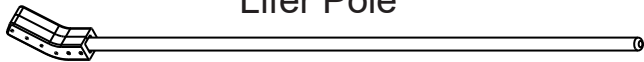

2 At one end of the track, position the Lifer Pole **underneath the tug main plate.**

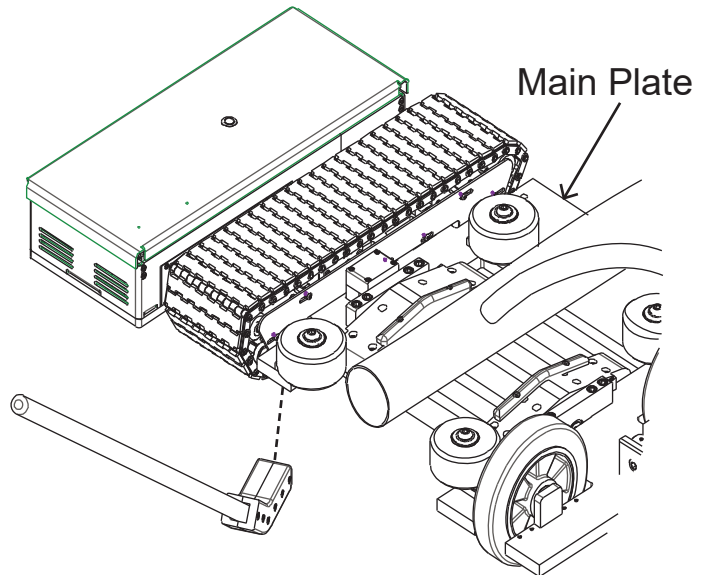

3 Rotate the pole to lift the track off the ground and install the first auxiliary wheel. There are 4 mating holes on the main plate, 2 per wheel. They are located at each end of the track.

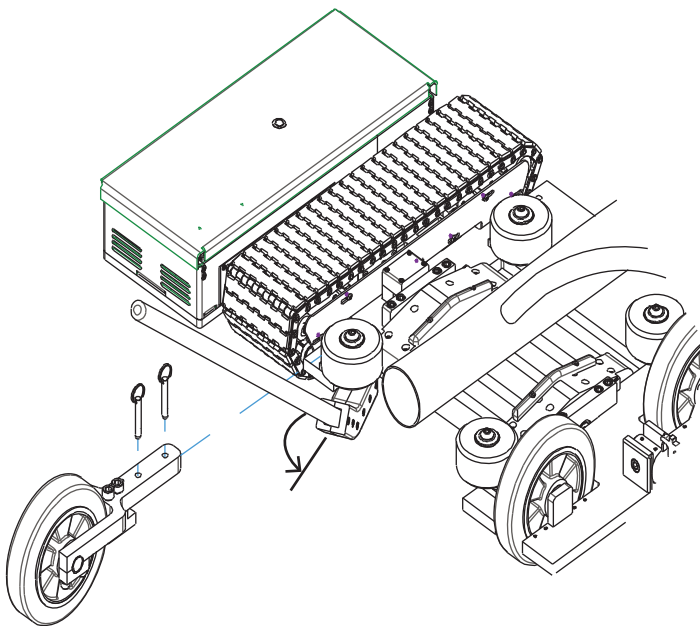

4 On the opposite end of the track, position the Lifer Pole underneath the main plate. Install the second auxiliary wheel.

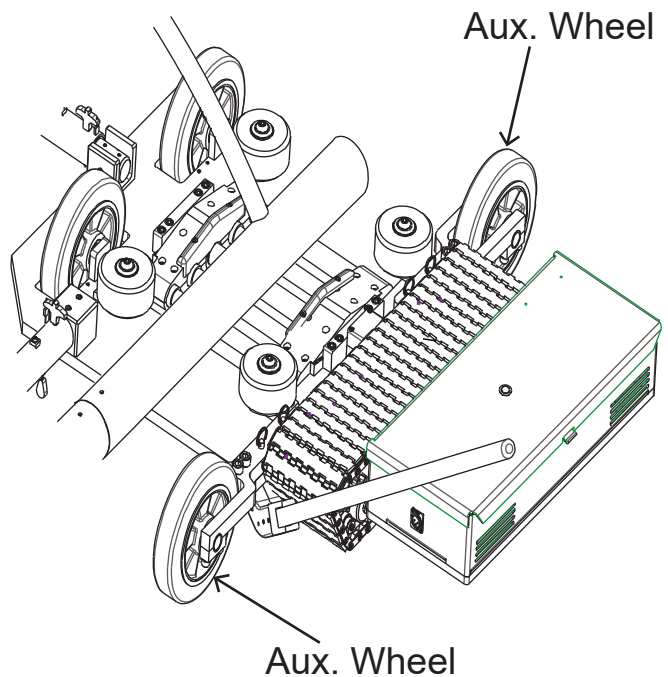

3. Tug Assembly

3-1 Front End Assembly

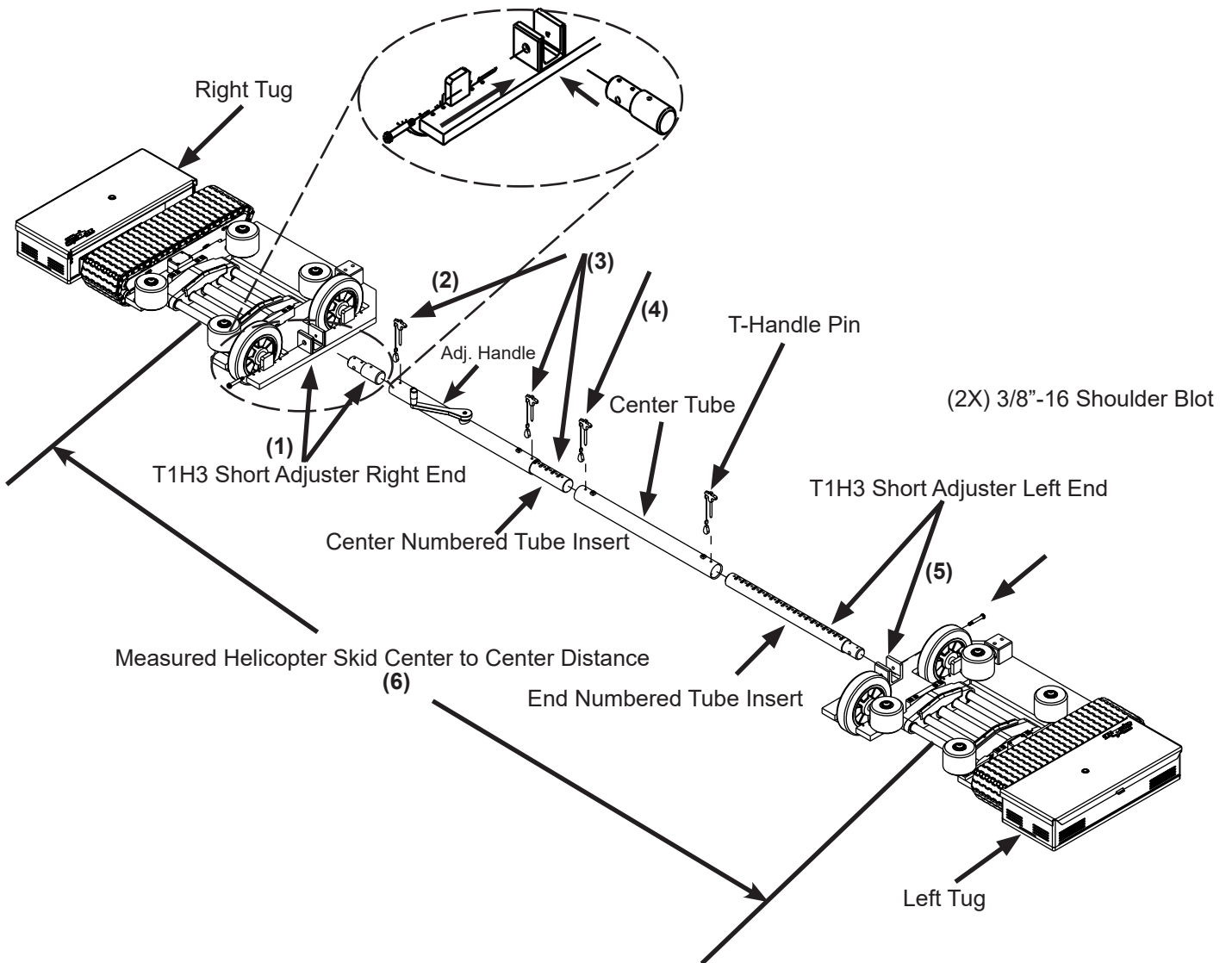

Assembly Figure 1

NOTE

BEFORE STARTING ASSEMBLY PROCESS PLACE BOTH RIGHT AND LEFT TUGS APART ABOUT 5 INCHES LESS THAN THE SKID WIDTH MEASURED EARLIER. IT IS POSSIBLE BOTH TUGS CANNOT BE PLACED 5 INCHES LESS WITHOUT INTERFERING AND IN THIS CASE THE TUG WIDTH WILL BE AT ITS MOST MINIMUM.

1. Slide the smaller diameter end of the Helicopter Frame Insert (Part #24244) into swivel connection shown above. Align the non threaded thru holes and while holding the insert in place screw in Shoulder Bolt (Part #95669).

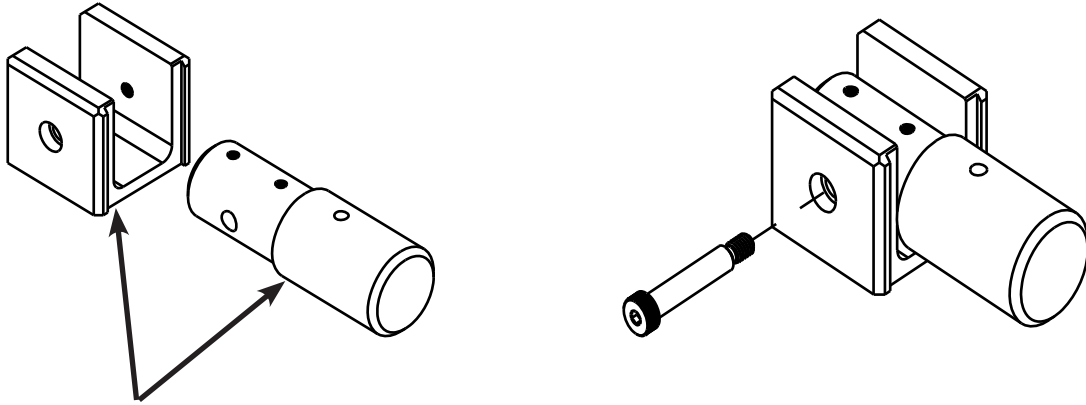

2. Insert larger diameter end of Helicopter Frame Insert (Part #24244) into the end of the tube of assembly #09621. Align the thru holes on both the helicopter frame insert and end of the tube shown and insert T-Handle pin (Part #95545) far enough until the handle cannot slide out freely.

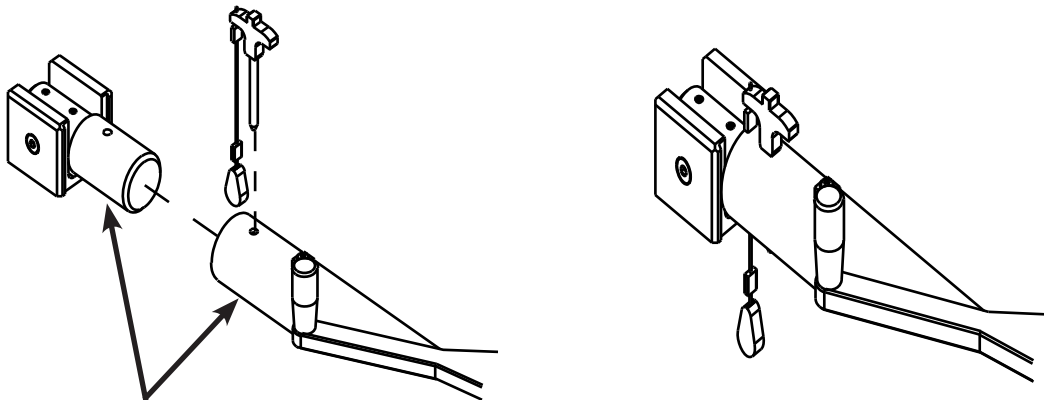

- Align the thru holes on both the center numbered tube and end of the tube shown and insert T-Handle pin (Part #95545) far enough until the handle cannot slide out freely. Take note this pin will be removed and adjusted in step 6 of this process when connecting both the right and left tugs.

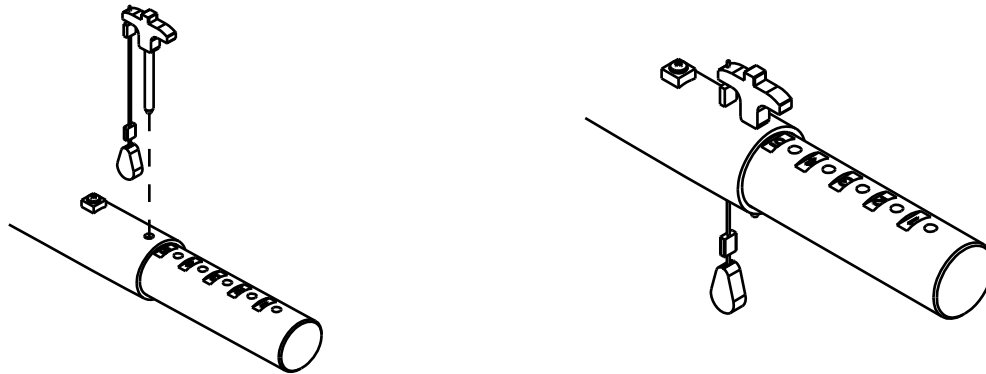

- Align the center numbered #1 thru hole and one end of the center tube shown and insert the T-Handle pin (Part #95545) far enough until the handle cannot slide out freely. Remove the T-Handle Pin on the side with the adjustment handle and leave out until the tug's width has been adjusted to the previously measured width. This connection does not adjust and will remain intact when adjusting the width of the T1H3 tug. Facing down on the adjustment handle turn it counter-clockwise until it can no longer turn.

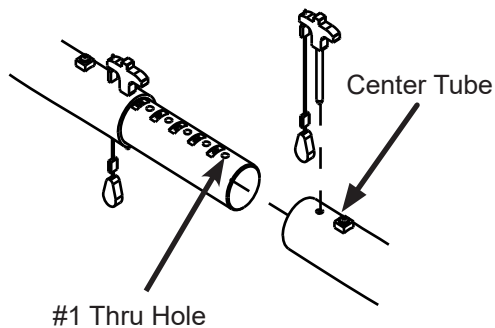

Figure 1

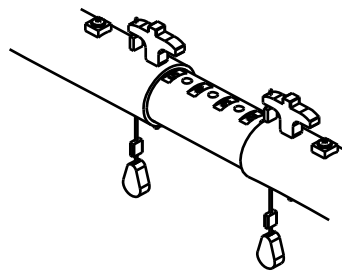

Figure 2

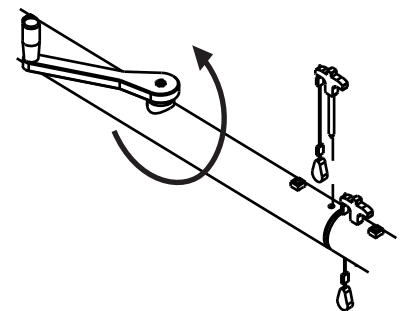
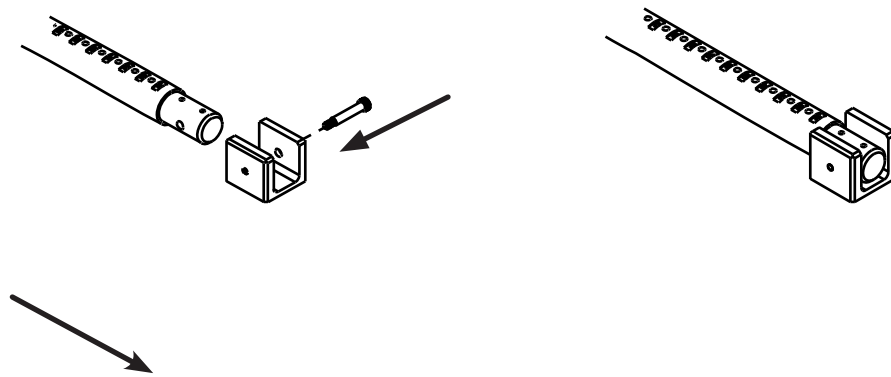
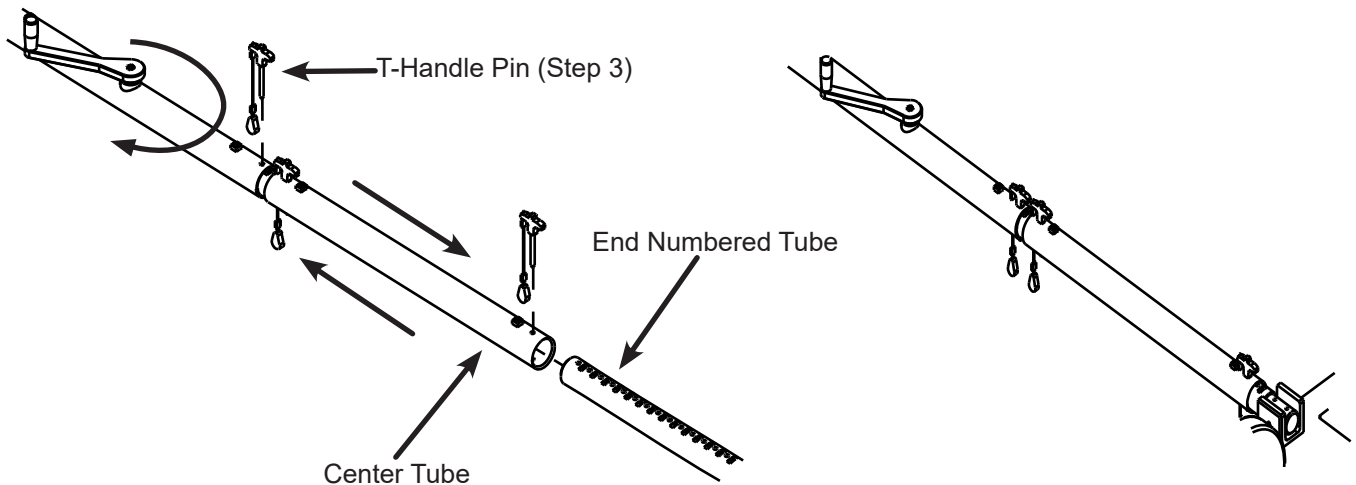

Figure 3

5. Slide the smaller diameter end of the end numbered tube insert into the swivel connection shown above. Align the non threaded thru holes and while holding the insert in place screw in Shoulder Bolt (Part #95669).



6. With both tugs placed 5 inches less than the width measured, assuming it is possible and not at its minimum width, power one of the tugs on to aid in aligning the tubes. Align the center tube and the end numbered tube insert so they are concentric with one another. Remove the T-Handle pin from step three and looking down on the adjustment handle rotate it clockwise guiding the tube to the desired length. Once the desired length has been achieved insert the T-Handle pin to connect both the center tube and end numbered tube together



7. Both the right and left tugs are now connected together. Take note of the numbers the T-Handle Pins have been inserted to after adjustment is complete as shown in the figure below. These numbers will aid with the back end assembly width adjustment in the final step.

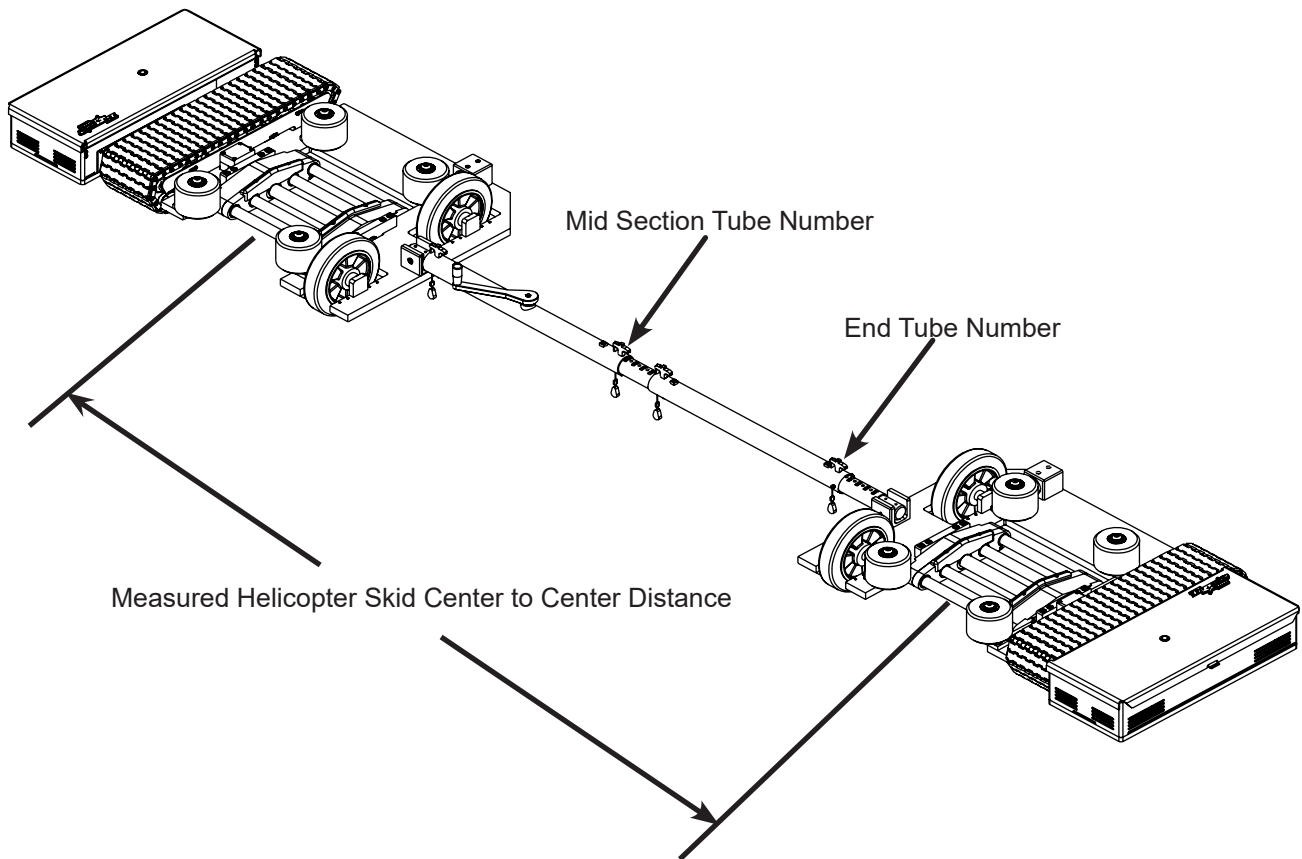

8. Insert (2x) T1H3 Frame Insert into the separate Heli Rail Support blocks attached individually to each tug. Align the two threaded holes on each of the T1H3 Frame Inserts with the thru holes on the Heli Rail Support blocks. Using a 3/16" allen wrench screw in and firmly tightened (4X) socket head screws, two per side. Insert (2X) Frame Side Support tubes into the larger diameter ends of T1H3 Frame Inserts. Align the thru holes on both the T1H3 Frame Insert and Frame Side Support and insert (2X) T-Handle Pin for each side.

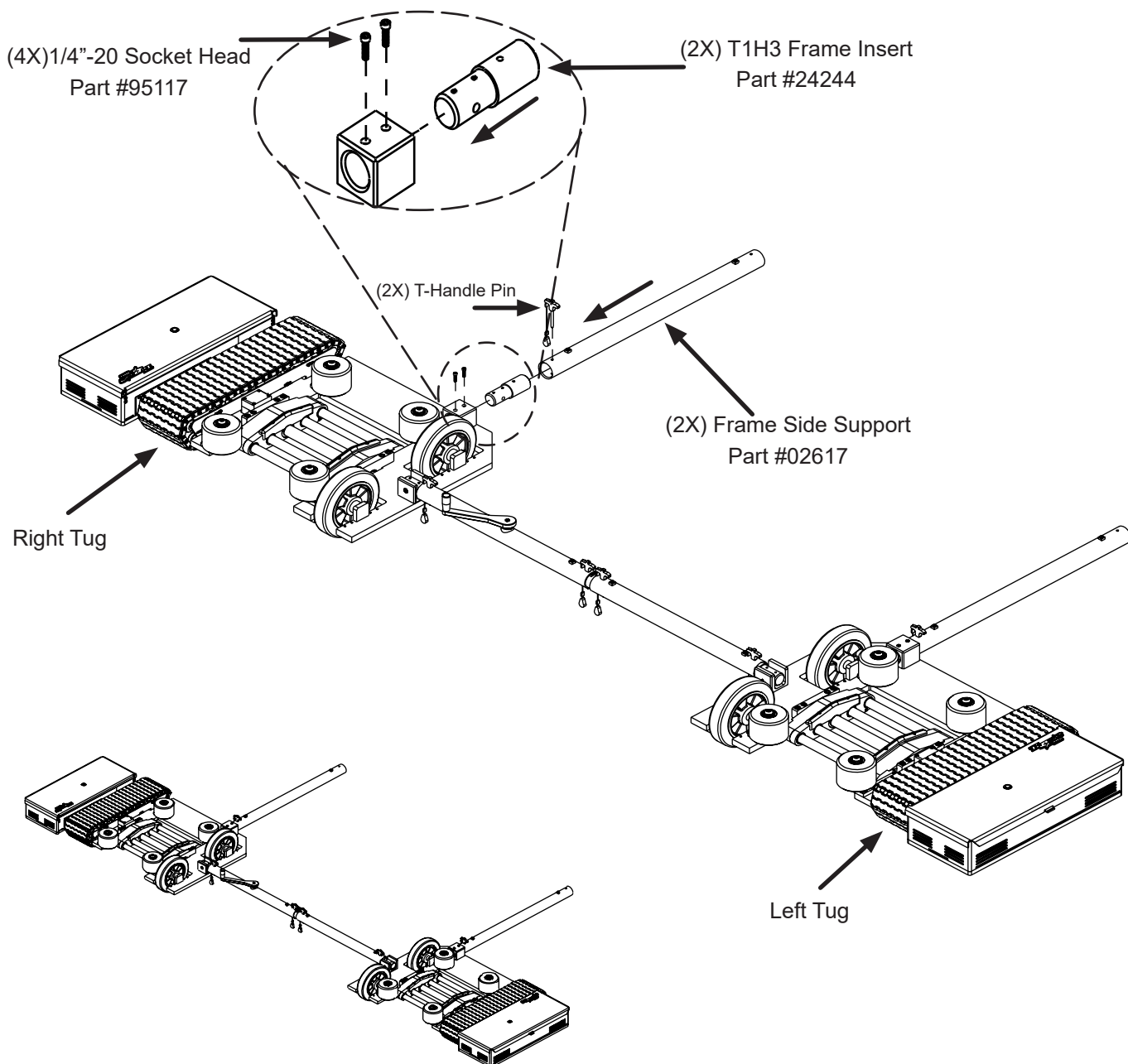

3-2 Back End Assembly

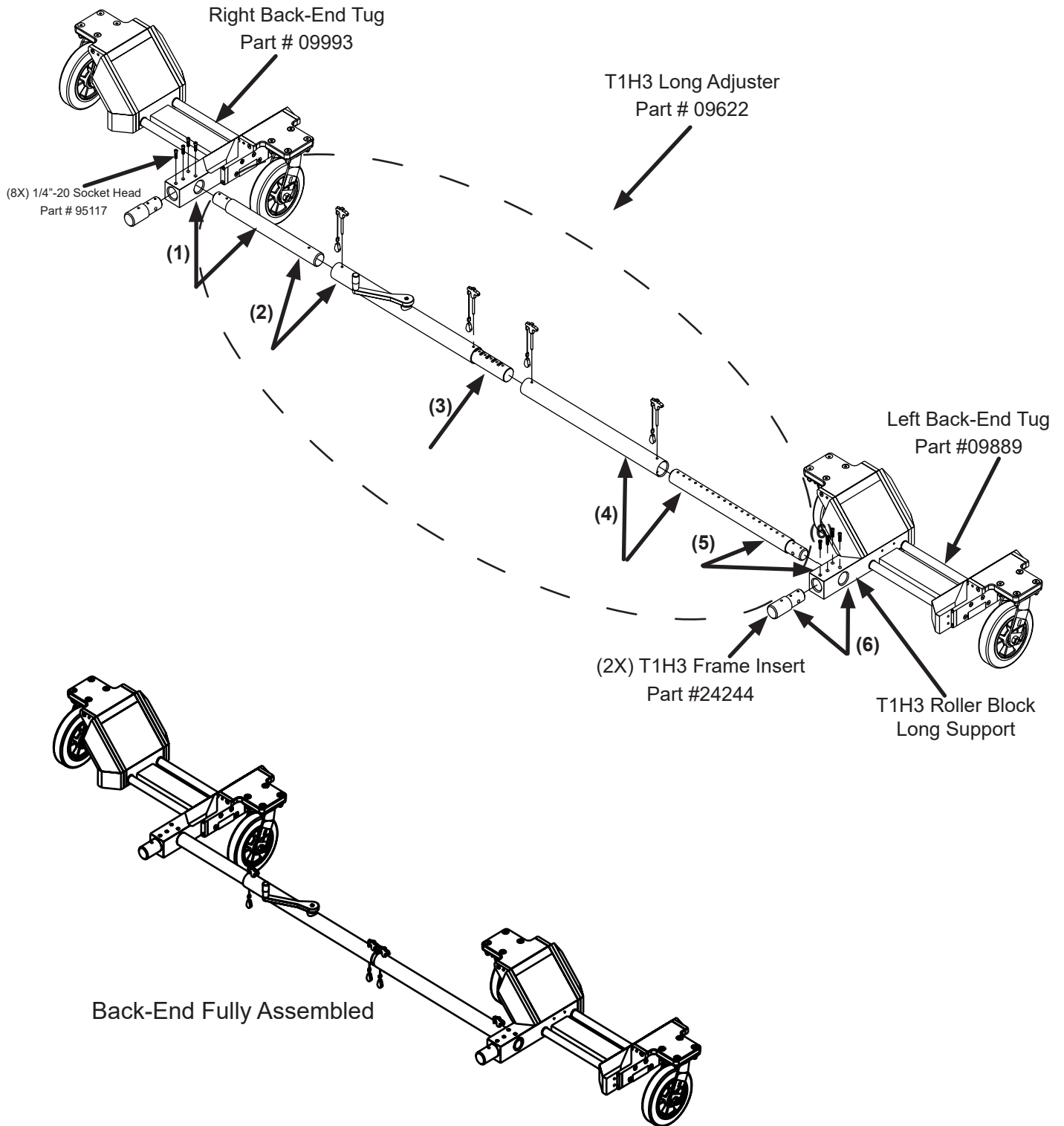

1. Insert (2X) T1H3 Frame Insert into the separate T1H3 Roller Block Long Support attached individually to each of the back-end assemblies. Align the two threaded holes on each of the T1H3 Frame Inserts with the thru holes on the T1H3 Roller Block Long Supports. Using a 3/16" allen wrench screw in and firmly tightened (4X) socket head screws, two per side. Insert Fixed Long Frame Insert into the T1H3 Roller Block Long Support on the right side back-end assembly. Align the two threaded holes on the fixed long frame support with the thru holes on the T1H3 Roller Block Long Support. Screw in and firmly tightened (2X) socket head screws.

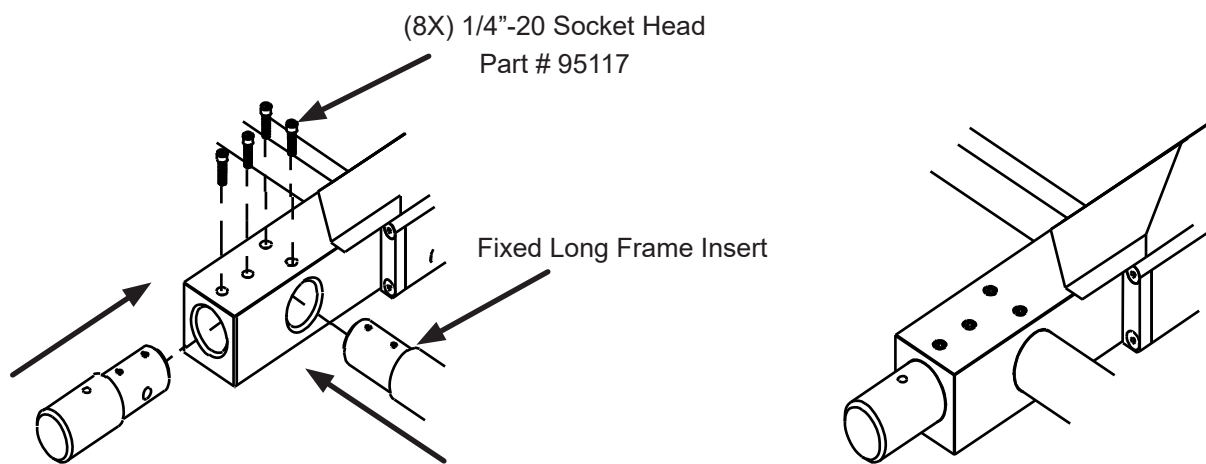

2. Insert fixed long frame support into the long adjuster mid-section end closer to the adjustment handle. Align the thru holes on each end and insert a T-Handle pin to attach both.

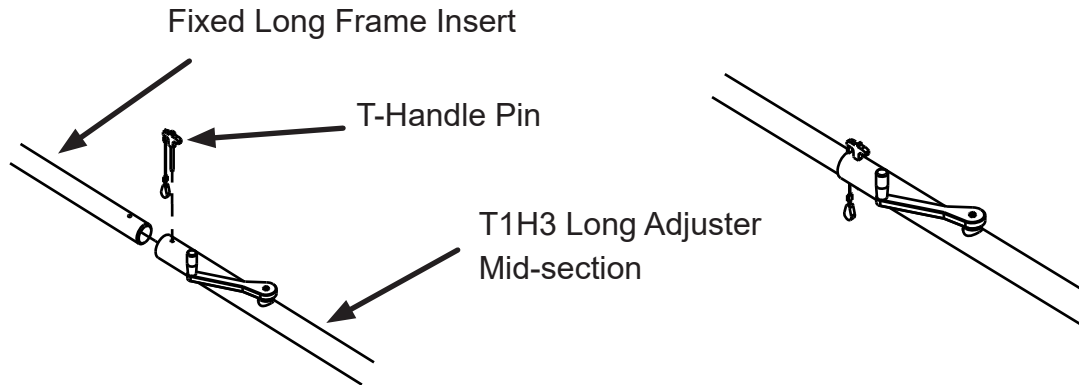

3. Align the center numbered tube #1 thru hole and one end of the center tube shown and insert the T-Handle pin (Part #95545) far enough until the handle cannot slide out freely. Remove the T-Handle Pin on the side with the adjustment handle and leave out until the tug's width has been adjusted to the previously measured width. This connection does not adjust and will remain intact when adjusting the width of the T1H3 tug. Facing down on the adjustment handle turn it counter-clockwise until it can no longer turn.

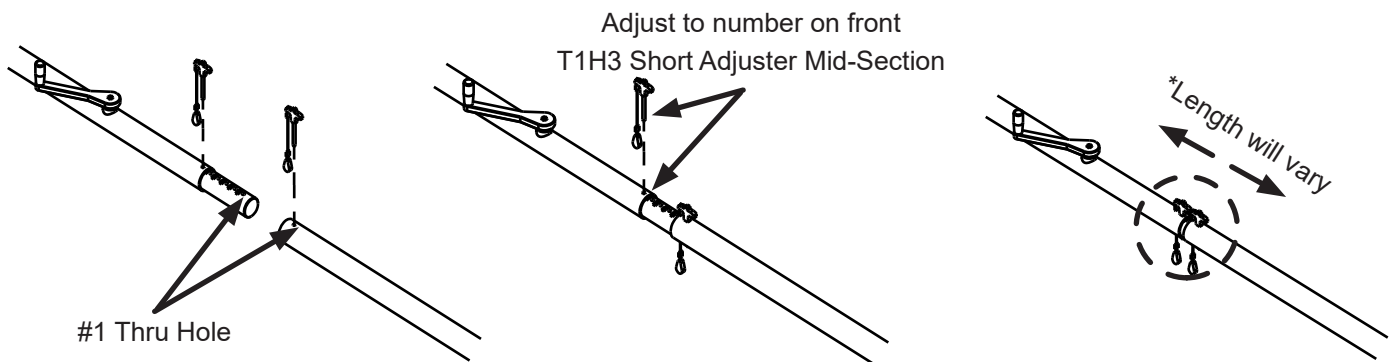

Figure 1

Figure 2

Figure 3

Length will vary depending on the T1H3 short adjuster

- Align the center tube and the end numbered tube insert so they are concentric with one another. Insert the T-Handle pin into the number previously recorded from the T1H3 short Adjuster end and connect both the center tube and end numbered tube together.

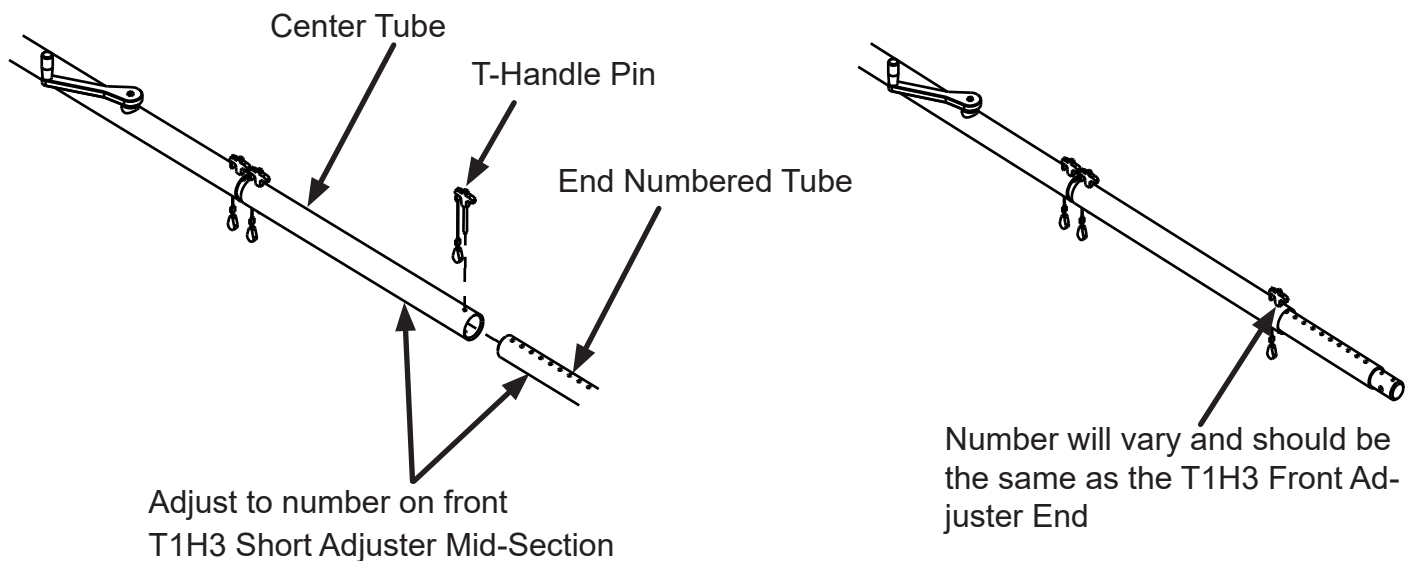

- Insert the T1H3 Long Adjuster End Numbered tube into T1H3 Roller Long Block and align the two threaded holes with the thru holes on the Left Back-end assembly. Screw in (2X) 1/4"-20 Socket Head to secure the Long Adjuster assembly to the Left Back-end Assembly.

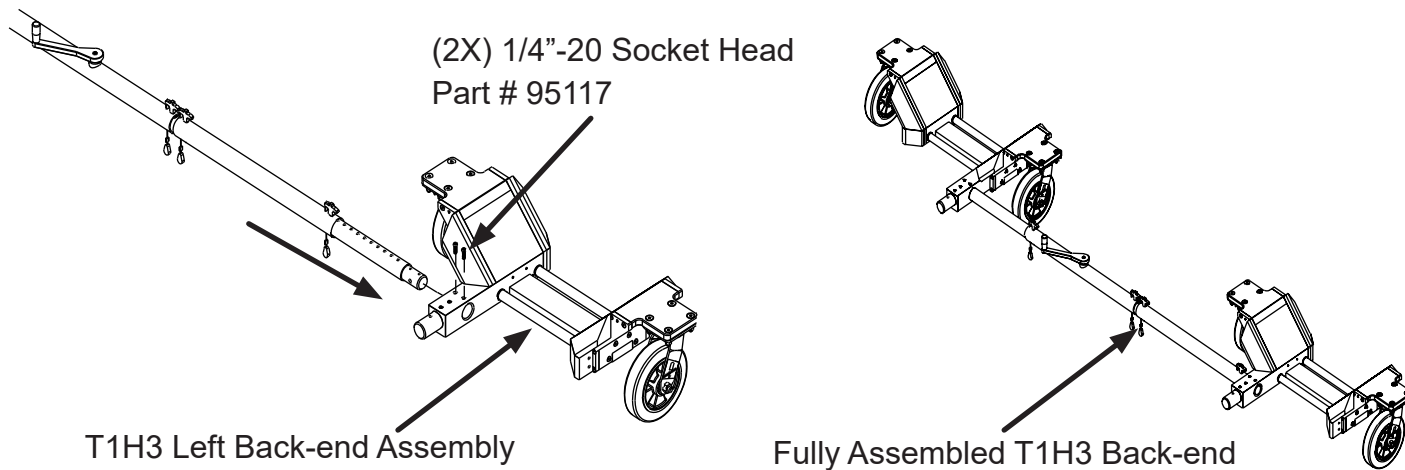

6. Align the back-end assembly with Heli Connector Tubes attached to both the Left and Right tugs as shown below. Slide in the T1H3 Frame Inserts into the Heli Tube Connectors and align the thru holes

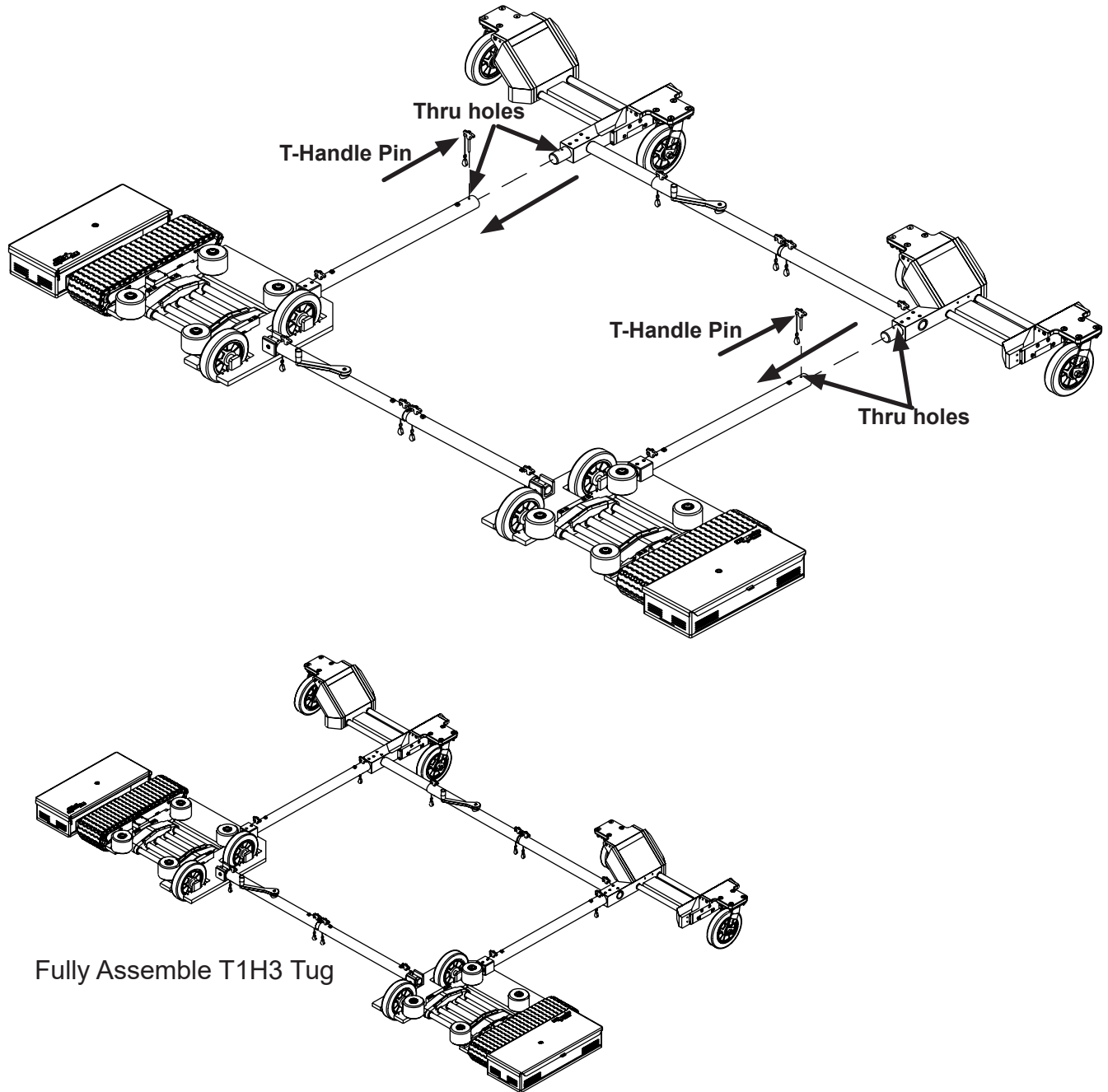

NOTE

T1H3 TUG WILL VARY IN WIDTH DEPENDING ON THE HELICOPTER IT IS UTILIZED TO MOVE. FIRST TIME LOADING SHOULD BE CAREFULLY OBSERVED BY OPERATOR TO ENSURE THE T1H3 HAS BEEN ADJUSTED TO THE PROPER WIDTH OF THE HELICOPTER SKIDS

4. Tug Operation

4-1. Radio Operation

1. Switch the radio on and make sure the power indicator light turns on and the radio beeps once. If this does not happen, check to make sure the batteries were installed correctly. When the battery level in the radio becomes low the radio will begin to beep, signaling you to replace or recharge the batteries.
2. To drive the tug, move the control stick in the desired direction.
3. The Roller Engage, Lock & Free Roll Switch is a 3 position switch. The Roller Engage position is used to drive the cradle rollers when loading and unloading the helicopter. The Lock position is to lock the rollers from turning after the helicopter is loaded on the tug. Free Roll is for manual unloading only.

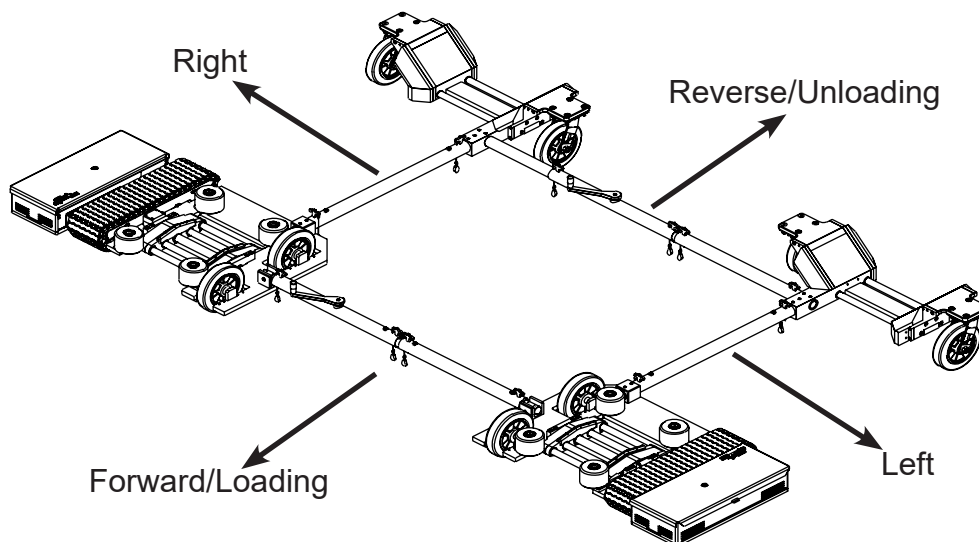
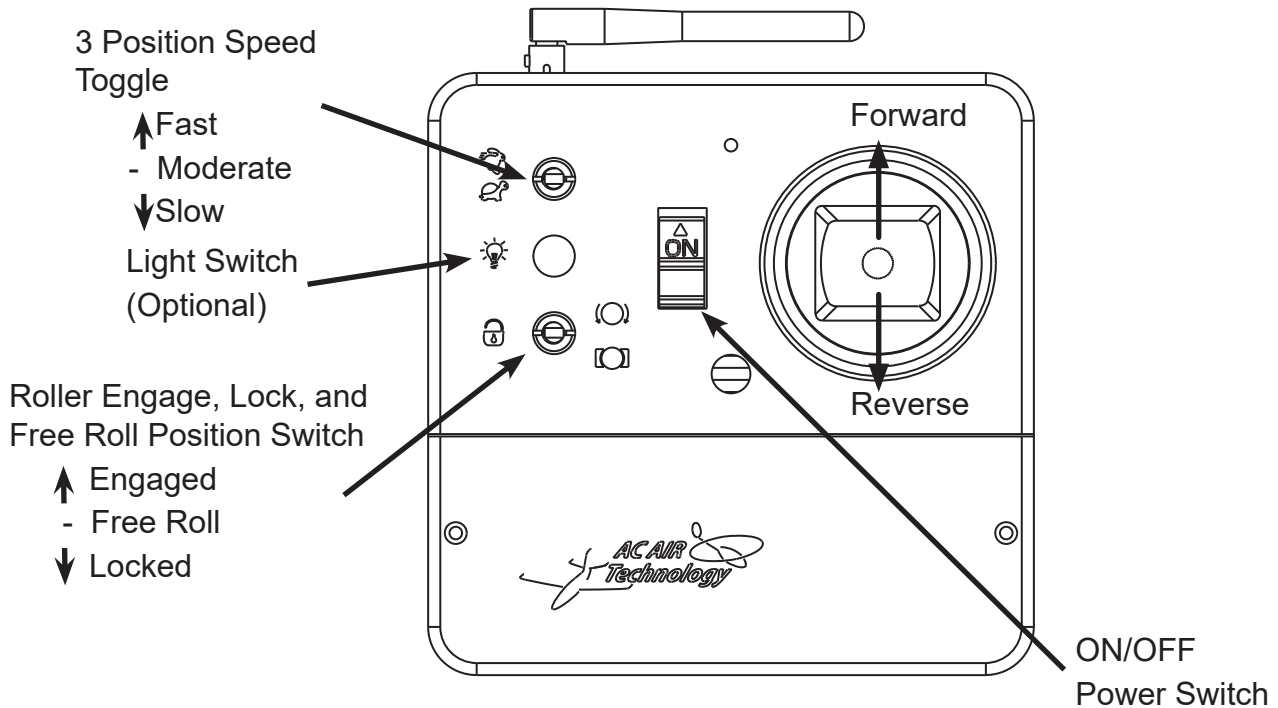

4-2. Operating the Tug

Before turning on the tugs, make sure the tracks and bottom of the tugs are free from obstruction.

Turn the tugs on using the ON/OFF switch. There will be a short series of beeps and then the ON/OFF switch will illuminate red to show the tug is on. The ON/OFF switch light will be on solid when the battery is fully charged. When the battery is low the ON/OFF switch light will blink and there will also be a beeping sound.

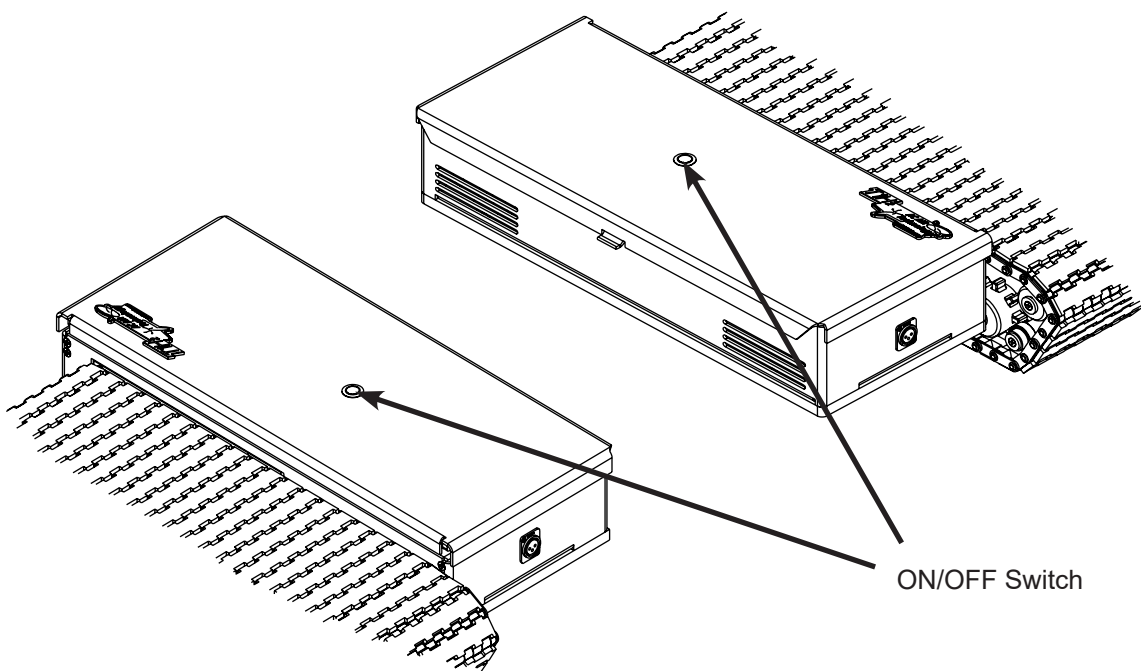

1. Turn on the power switch on the radio controller. The power indicator LED will illuminate green/blue in color. **It is recommended that you practice maneuvering the tug prior to loading the plane.**
2. It is recommended to use the radio in fast speed mode. Moderate and Slow speed mode should be used when maneuvering in tight quarters as it reduces the tugs power output
3. When towing your helicopter ALWAYS be cautious of your surroundings in regards to both the main rotor blades and tail rotor. Do not make any fast turns with the tug.

4. After lifting the tugs off of the ground for any reason or taking it in and out of your transportation vehicle, you must check to make sure that the sprockets are correctly seated on the tracks. If the sprocket is not properly seated it could result in damage to the track.

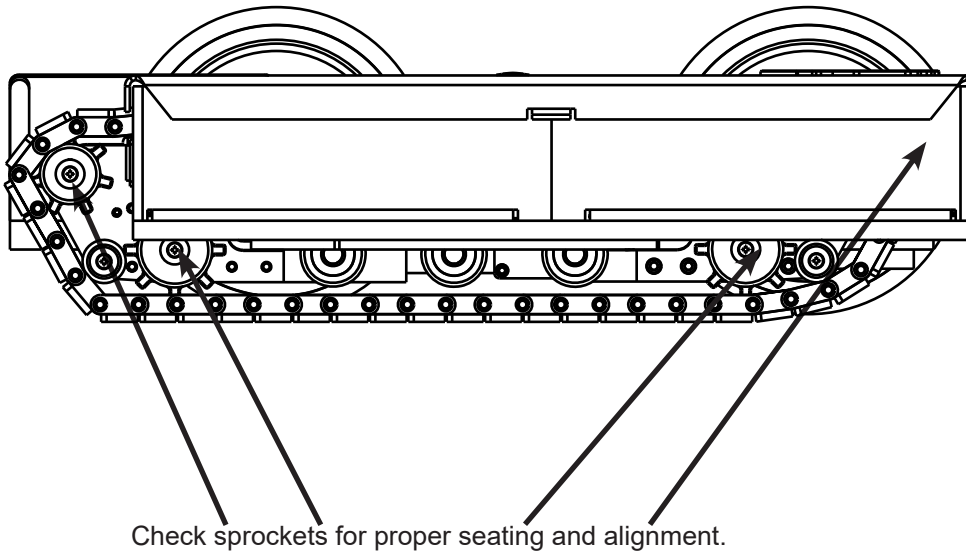

5. Visually check tracks for wear on the treads and wear on the inner plastic surfaces. Also inspect for damaged or missing rotoclips as a result of driving over small rocks. Damaged treads should be replaced before operating the tug.
6. It is recommended to operate the tug without loading the helicopter to become familiarized with the tug's functionality.

4-3. Adjusting the Width of the T1H3 Tug

1. Use the front and back cranks to adjust the width between the right side and left side tugs. Use the numbers on the extension tubes as reference for getting the front and back connecting tubes set at equal lengths.

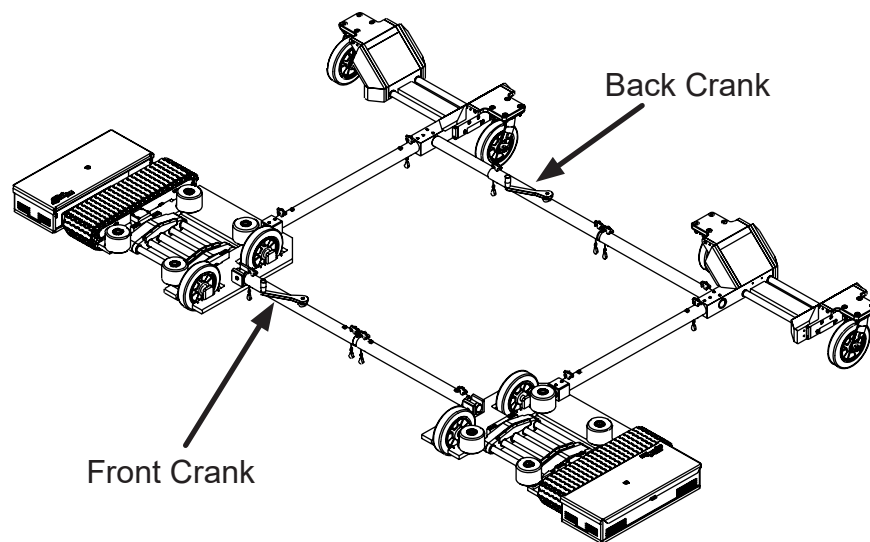

HINT #1: Use a tape measure to measure the Center to Center distance of the skids and then use the tape measure to set the tug width.

HINT #2: Use two people adjusting the two cranks at the same time to speed up the process.

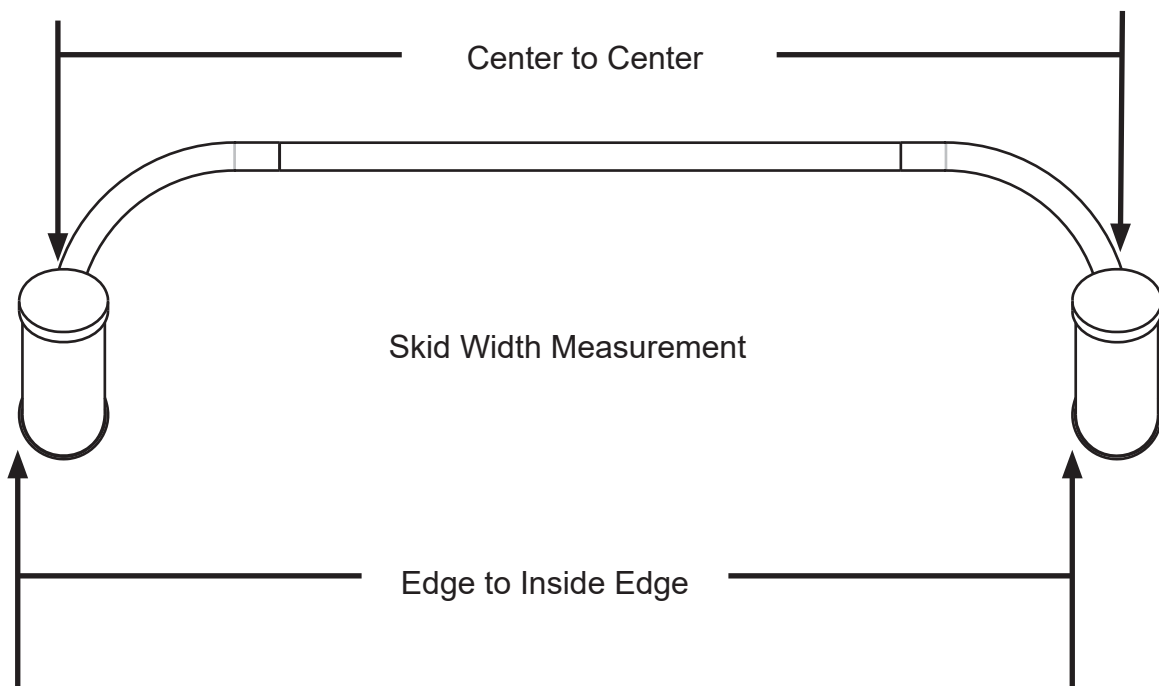

4-4. Loading the T1H3 Under the Helicopter Skids

1. Identify the center of gravity (CG) and mark or be able to readily identify its location as shown in the picture Fig. 3-1.

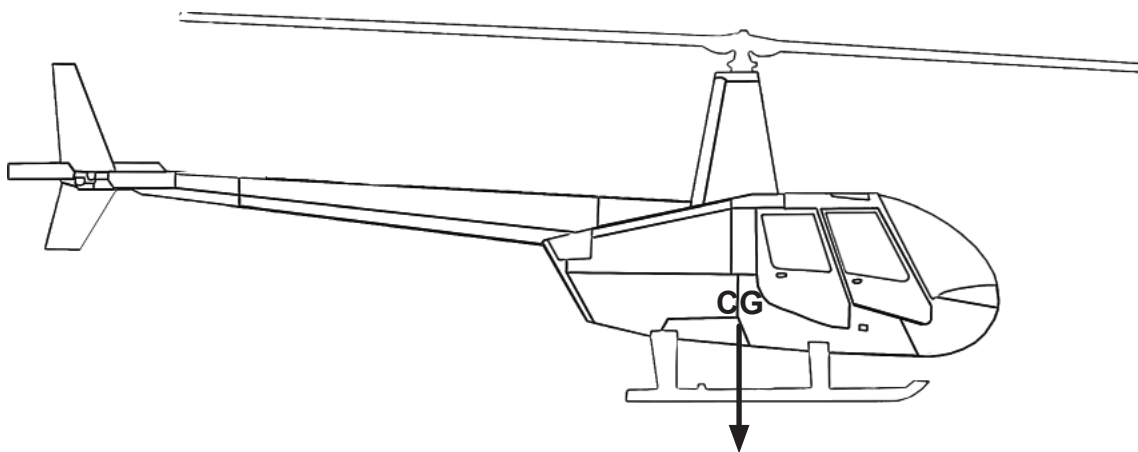

NOTE:

The center of gravity (CG) will vary depending on the model of helicopter

2. Place the Air Bag directly below and centered with the tail as shown in the picture Fig. 3-1.

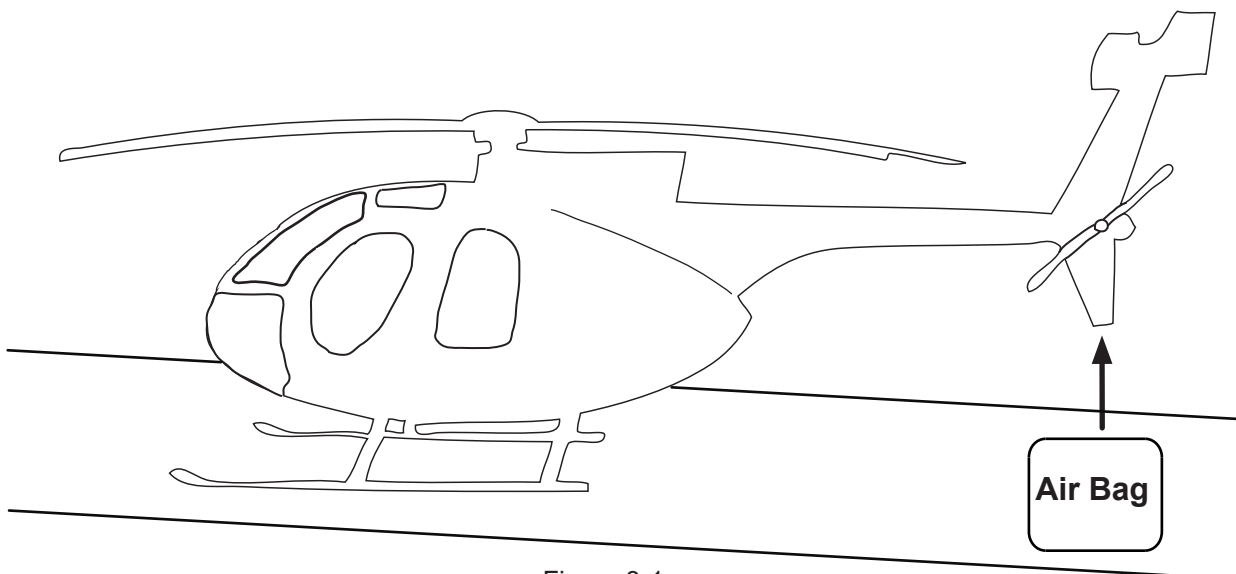
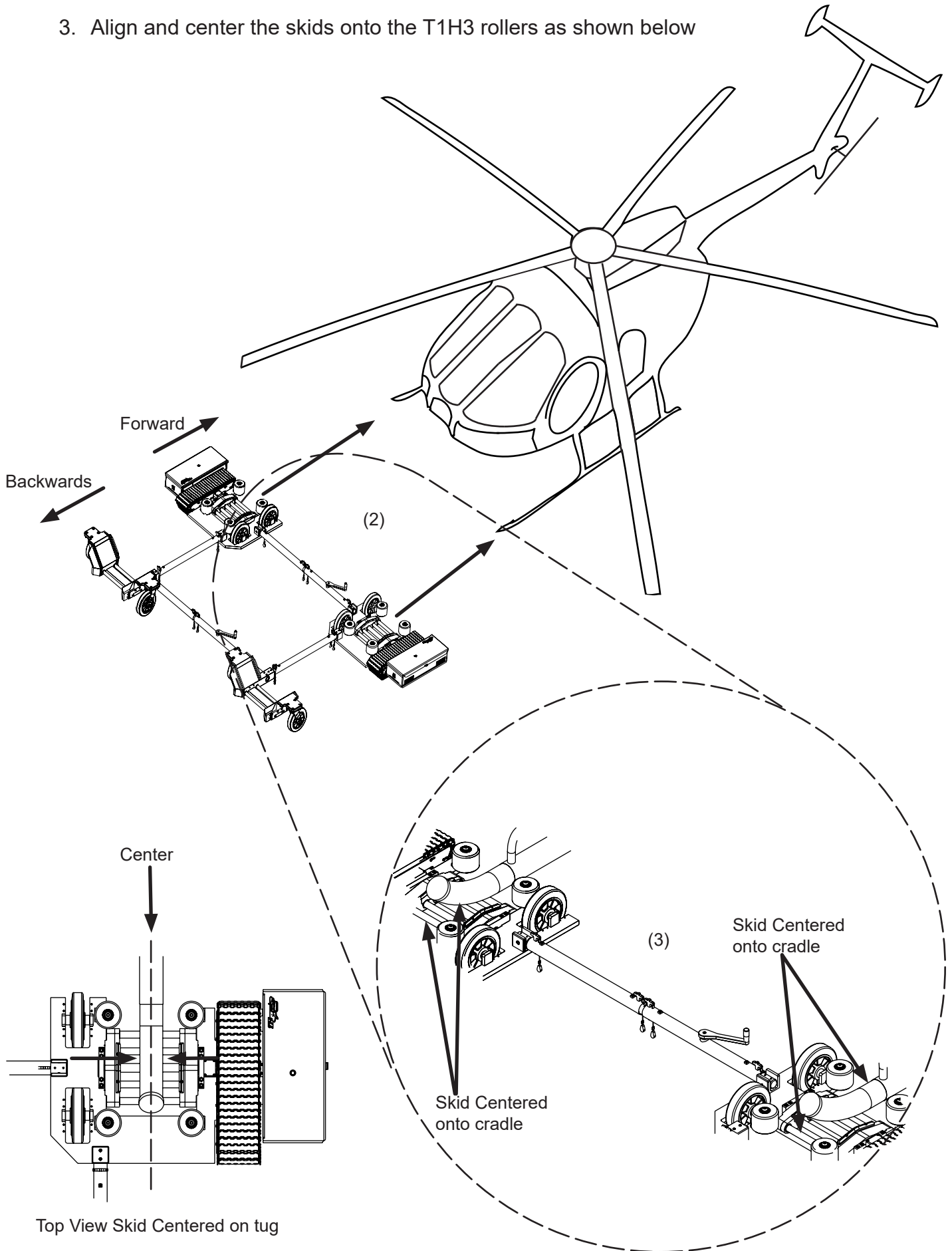

Figure 3-1

3. Align and center the skids onto the T1H3 rollers as shown below



Top View Skid Centered on tug

4. Ensure the position on your transmitter is set to engage mode. Slowly move the tug forward and backwards until you visually confirm the rollers on the cradle are fully engaged and are turning when the tug moves. Approach the skids slowly and align your tug so the skids on your helicopter are centered onto the rollers as pictured below. Slowly advance forward/load helicopter while maintaining the skids centered as much as possible. If skids go off center adjust position by turning either left or right until centered once again.

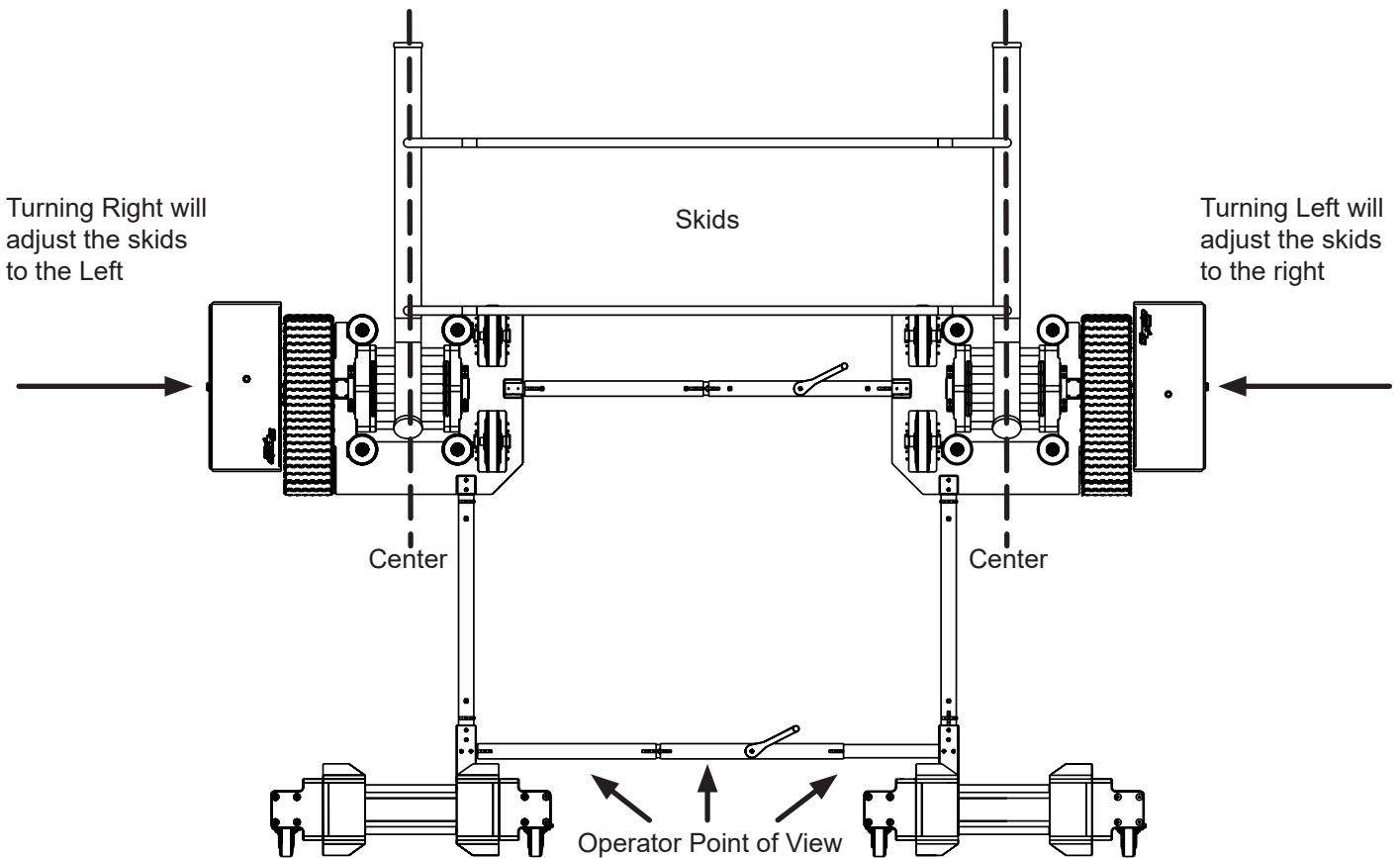
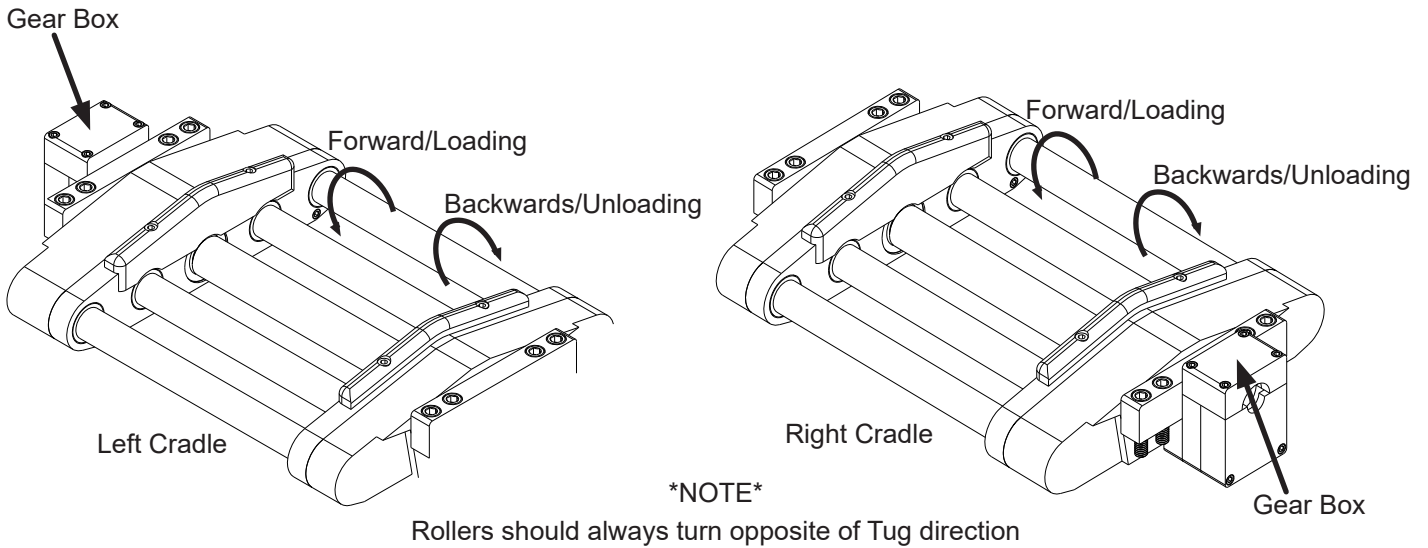

5. Slowly drive the tug forward under the skids. As you drive under the skids the front of the helicopter will raise up and the tail will lower down. Verify the air bag is positioned under the tail properly to prevent the tail from hitting the ground. Then proceed with loading.
6. While loading the helicopter the front of the skids will be raised above the back-end cradles and eventually drop down as you proceed forward. The drop can be easily controlled by holding the tail at the critical drop point and easing the skids down slowly. Make sure the fronts of the skids are centered in the Back-End cradles of the tug.

WARNING

DO NOT LET THE BACK OF THE SKIDS GO PAST THE MIDDLE ROLLER ON EITHER SIDE OF THE TUG.

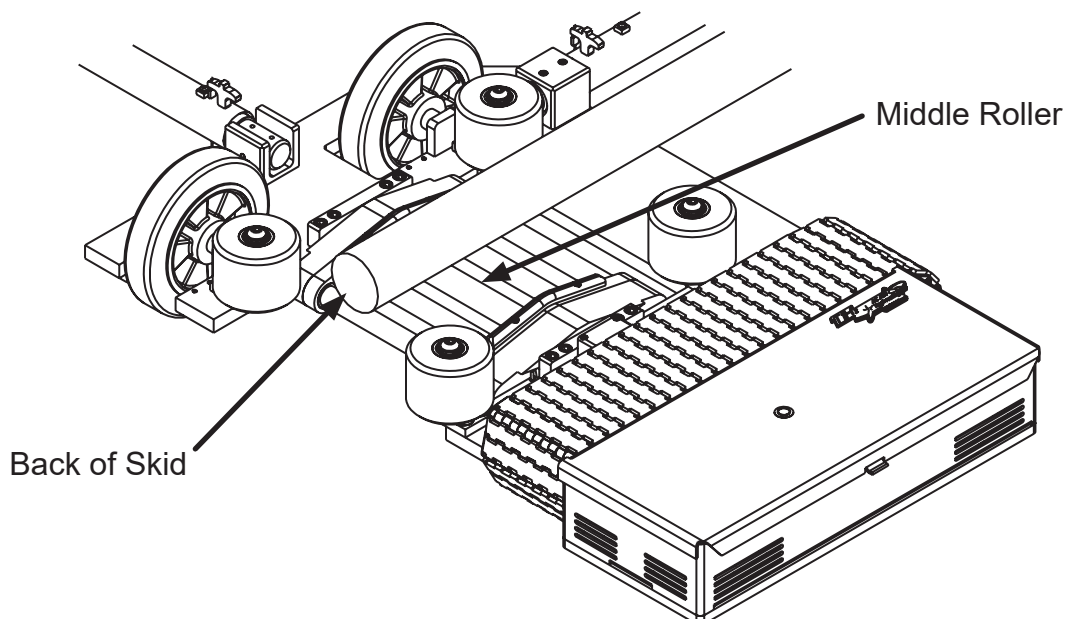
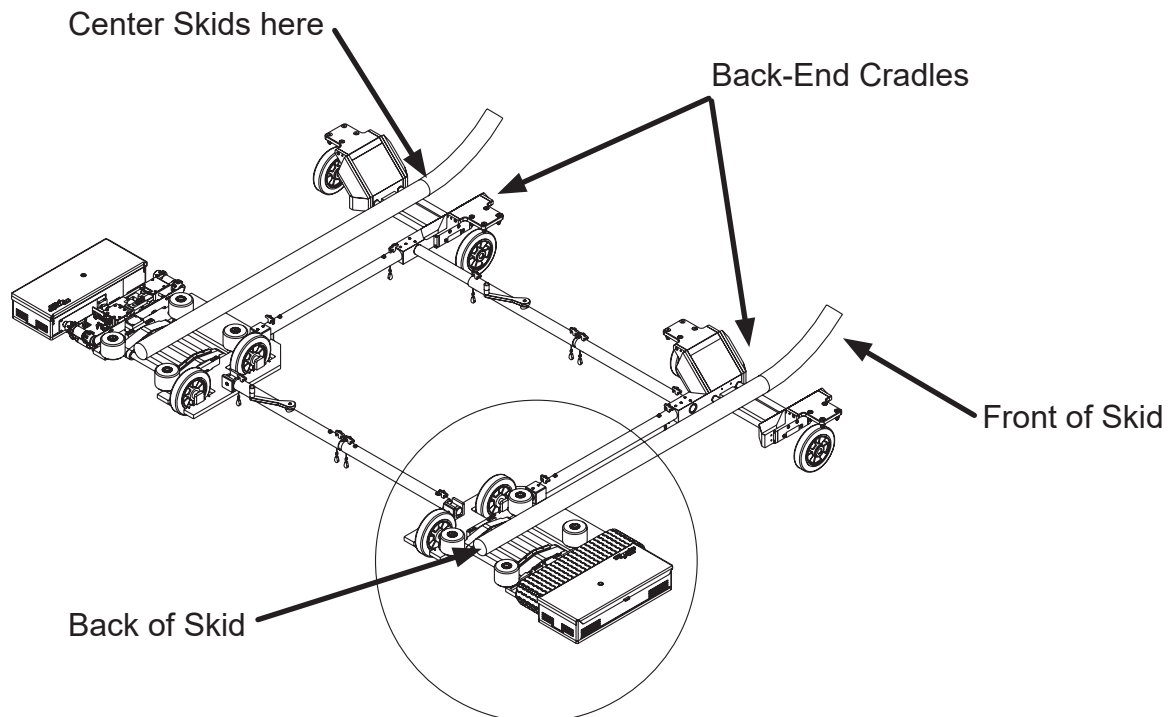

- When Loading the helicopter ensure the CG stays between the two points indicated below. If the CG passes the furthest from the loading side point indicated below immediately stop and reverse direction until it is back at the safe CG point or before.

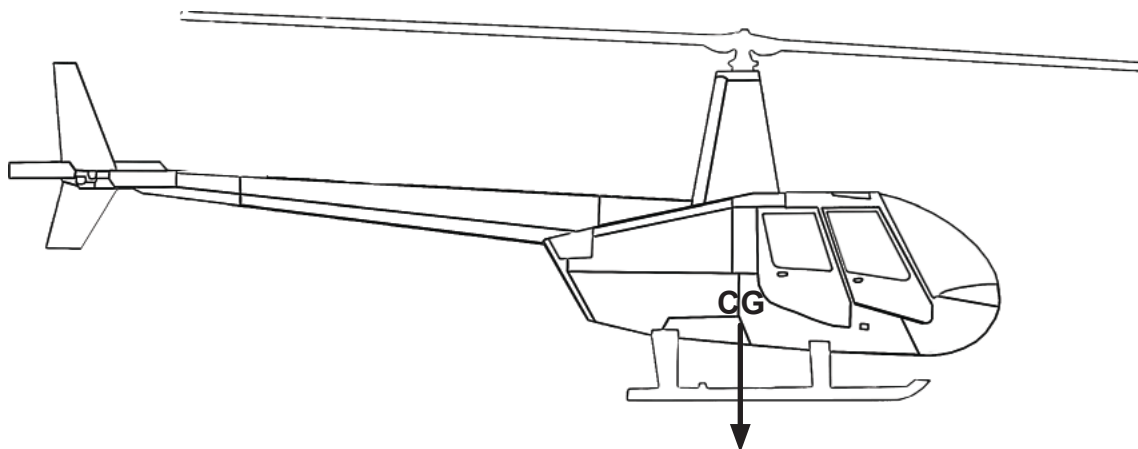

NOTE:

The center of gravity (CG) will vary depending on the model of helicopter being tugged.

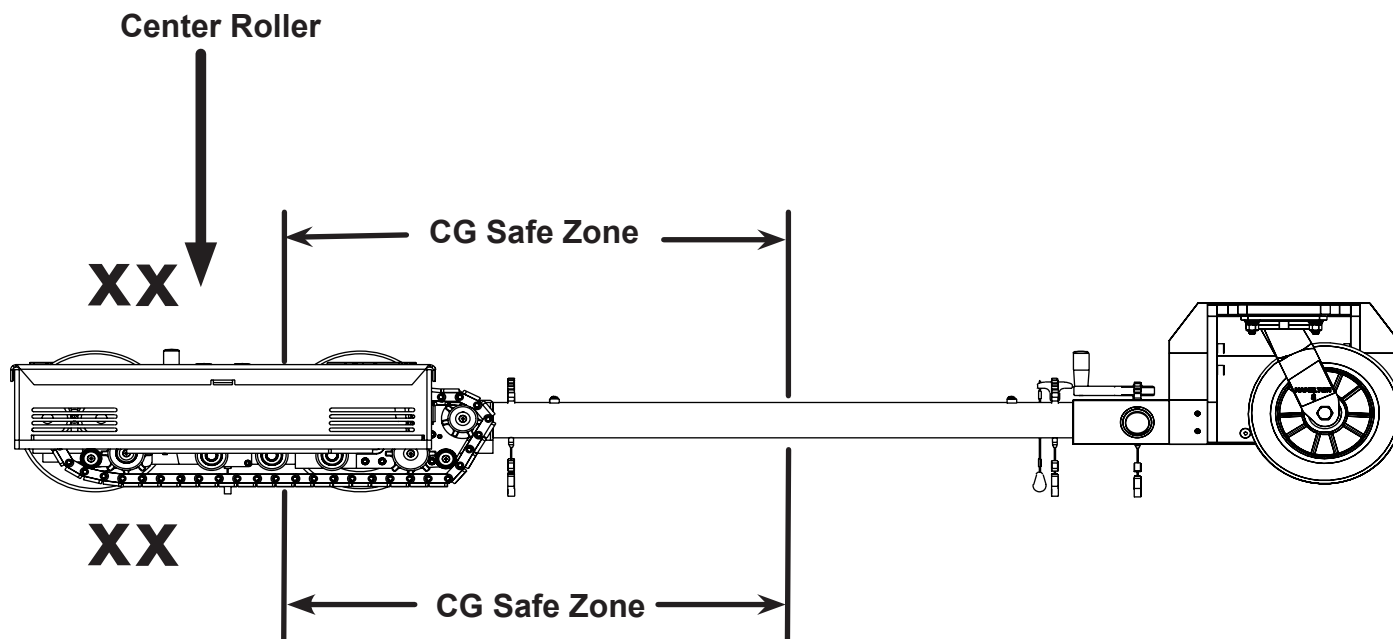

WARNING

CENTER OF GRAVITY SHOULD REMAIN WITHIN THE ARROWS AFTER LOADING HELICOPTER

- Once the helicopter skids are completely loaded in the proper location on the tug then switch the Roller Engage Switch to the Lock position (the down position). Then move the tug very slowly backwards and verify the rollers on both sides of the tug are not turning. If either one of them is turning then reverse the movement of the tug forward moving very slowly and verify the rollers are not turning.

WARNING

IT MAY TAKE SEVERAL SLOW JOGS BETWEEN FORWARD AND BACKWARDS BEFORE BOTH ROLLERS ARE LOCKED. DO NOT PROCEED UNTIL BOTH ROLLERS HAVE STOPPED TURNING.

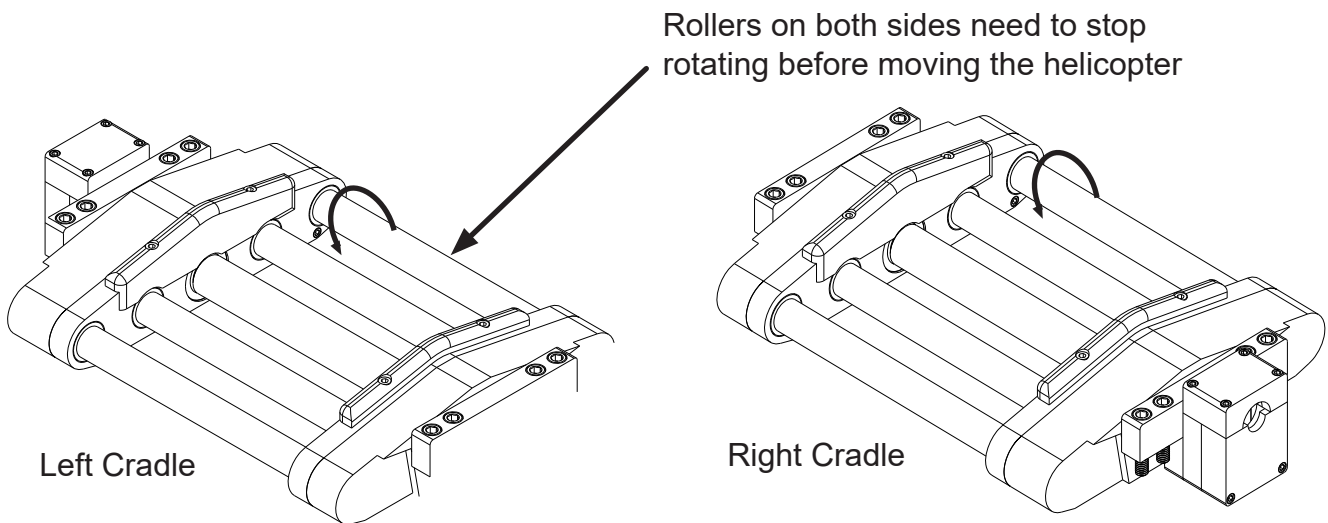
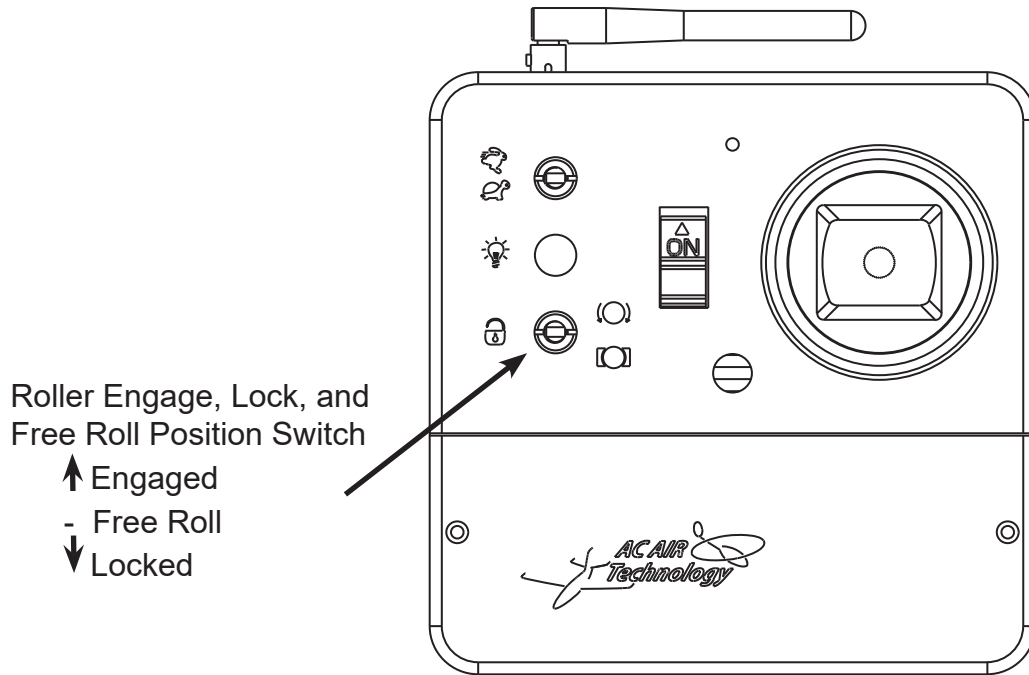

4-5. Moving the helicopter with the T1H3 tug

Use the joystick on the remote control to move the helicopter. Below are several notes to be aware of while you are moving the helicopter.

1. Carefully watch the position of the tail and rotors of the helicopter while moving.
2. When turning the tail of the helicopter can swing much faster than the expected.
3. When going up a slope make sure the center of gravity is far enough forward to prevent the tail from falling.
4. Do not make any sudden start or stop maneuvers.
5. If either side of the tug starts beeping then it is a “Low Battery” indication. Either swap out batteries with fresh charged ones or reconnect the chargers to the tug to recharge them.
6. Try and make gradual turns to extend the life of the tracks.
7. Watch the castoring wheels to ensure they are always leaning in the proper direction.

4-6. Unloading the helicopter from the T1H3 tug

1. Put the optional air bag under the tail or position a person at the tail to ensure it doesn't drop too low and hit the ground.
2. When you are ready to unload the helicopter just move the "Engage/Lock" switch from the "Lock" position to the "Engage" position on the remote
3. Slowly move the tug backward and visually check that the rollers on both sides are engaged and rolling. If they are not rolling then stop and slowly move forward and backward a few times until they are engaged.
4. When the rollers are engaged then just slowly back the tug out from under the skids.

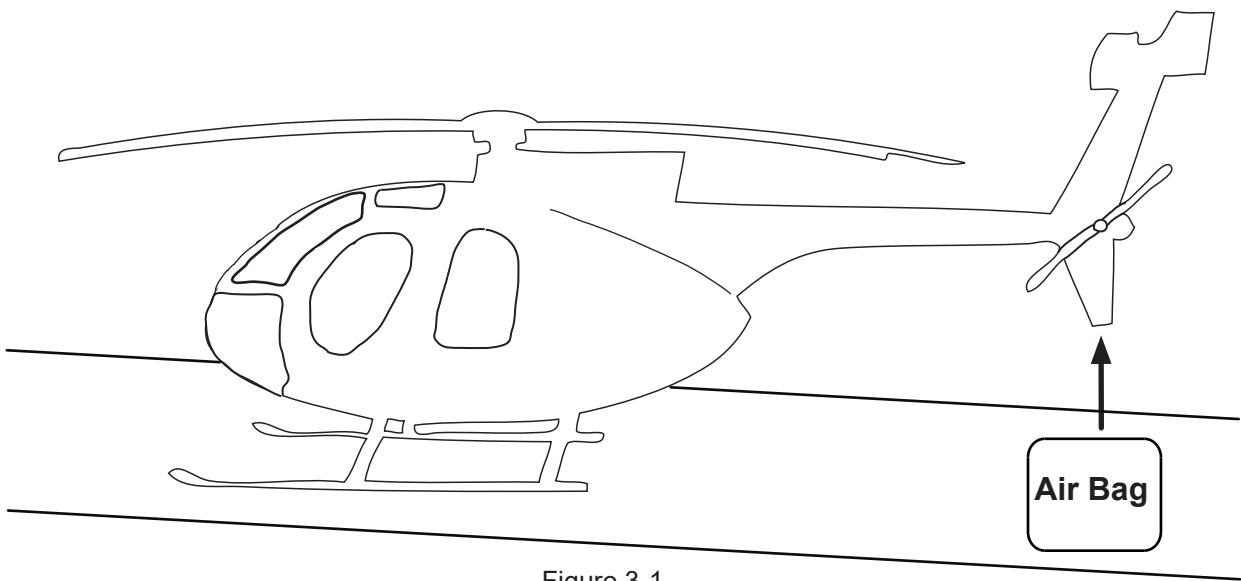

Figure 3-1

5. Tug Care

5-1. Adjusting the Track Tension

Track tension might need to be adjusted after several hours of use.
Follow the instructions below for each track.

1. Remove 6 track cover screws from each tug and remove the outside track covers.

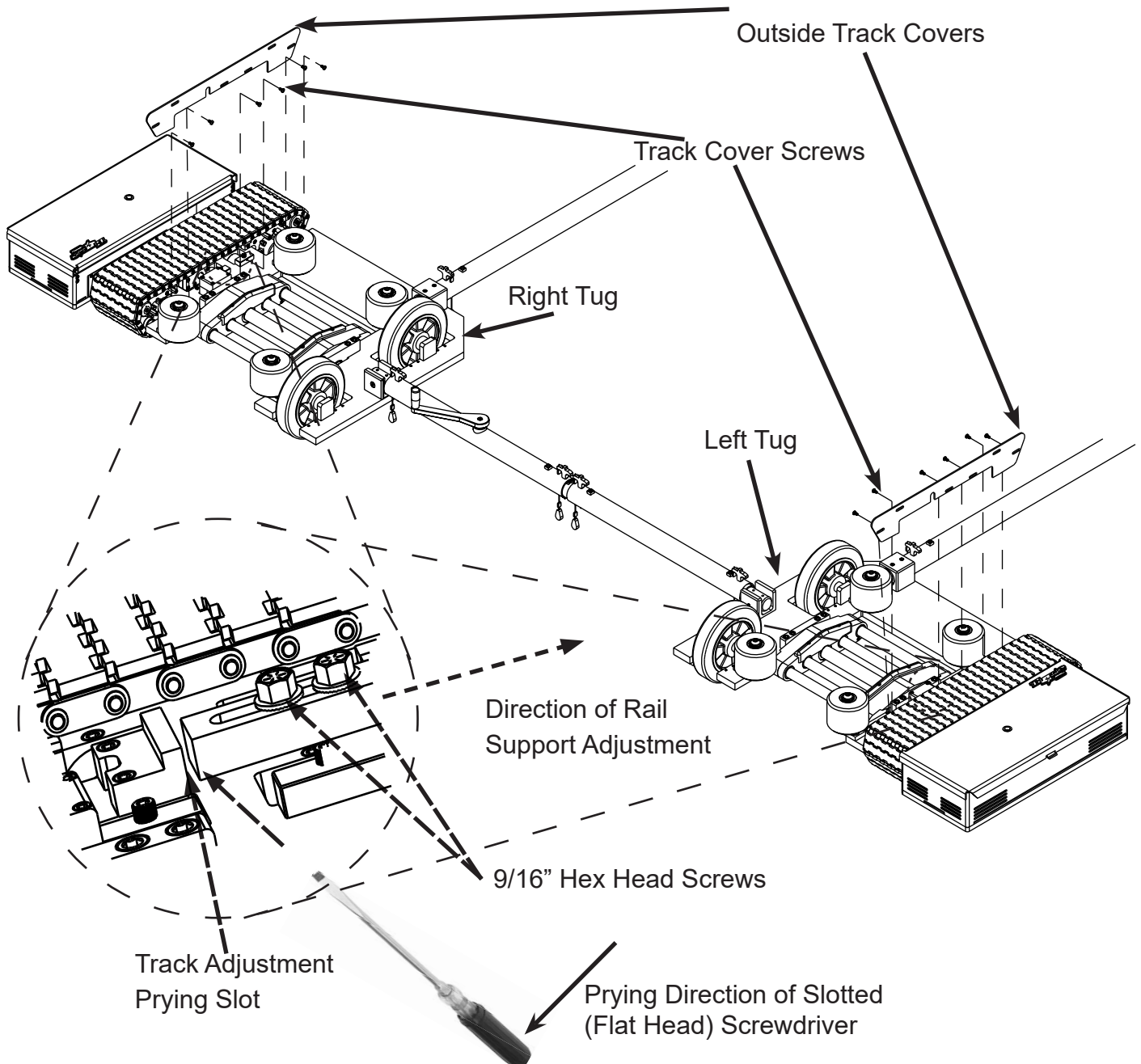

2. Use a 9/16\" hex socket and a ratchet to loosen Hex bolts shown above.

3. Next place a screwdriver in the track adjustment prying slot shown on the previous page

For the **Right side tug track (shown)** pry by pushing the screwdriver towards the front (loading side).

For the **Left side tug track** pry by pushing the screwdriver towards the back (non-loading side).

While holding the Rail Support Adjustment in place, tighten one of the 9/16" hex bolts so the rail remains in place without having to hold it with the screwdriver. Firmly tighten the other 9/16" hex bolt to 30ft.-lbs. followed by tightening the first hex bolt to 30ft.-lbs. Once the bolts have been the tracks has been adjusted and the tug is ready for use. Do not over tighten the tracks, they should only be adjusted to allow you to put two fingers between

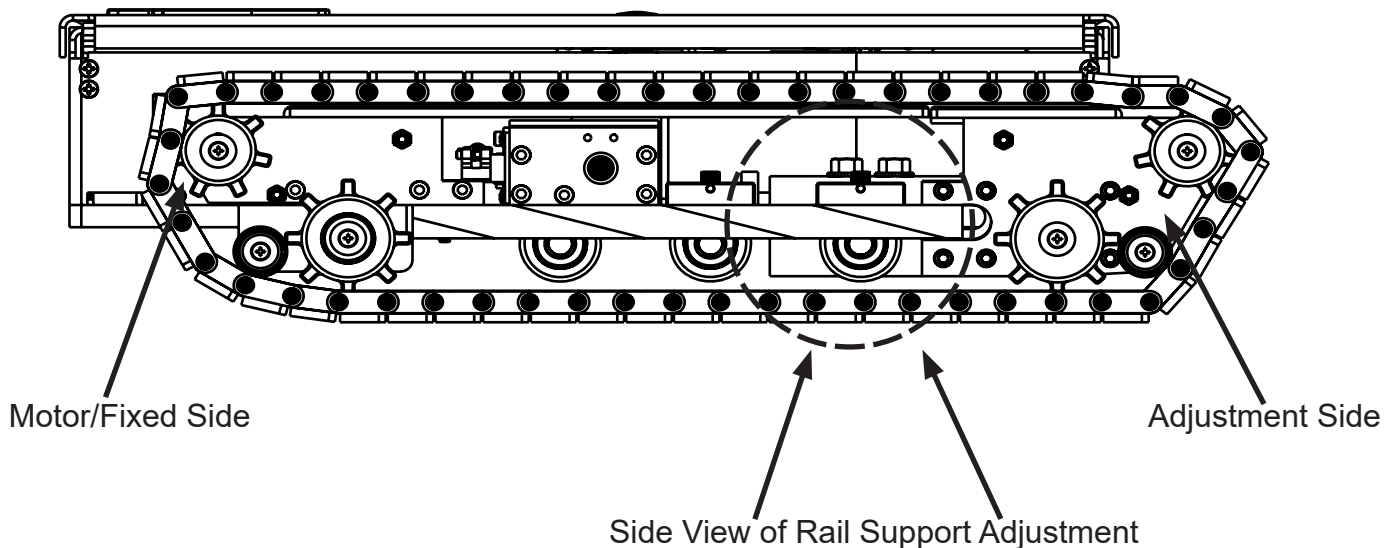

4. Once the track has been adjusted, tighten the front end retainer bolt.

5. Re-install the outside track cover.

6. Repeat steps 1 thru 5 for the other track.

To loosen the track for removal or repair follow these steps.

1. Remove the large outside cover from the side you want to loosen.

2. Use a 7/16" socket to loosen the front end retainer bolt.

3. Next use the socket to slightly rotate the hex track adjuster to relieve tension on the internal adjuster ratchet mechanism. CW for the left side, CCW for the right side.

5-2. Charging the Tug

1. Before charging your tug, the radio and tug should both be turned OFF.

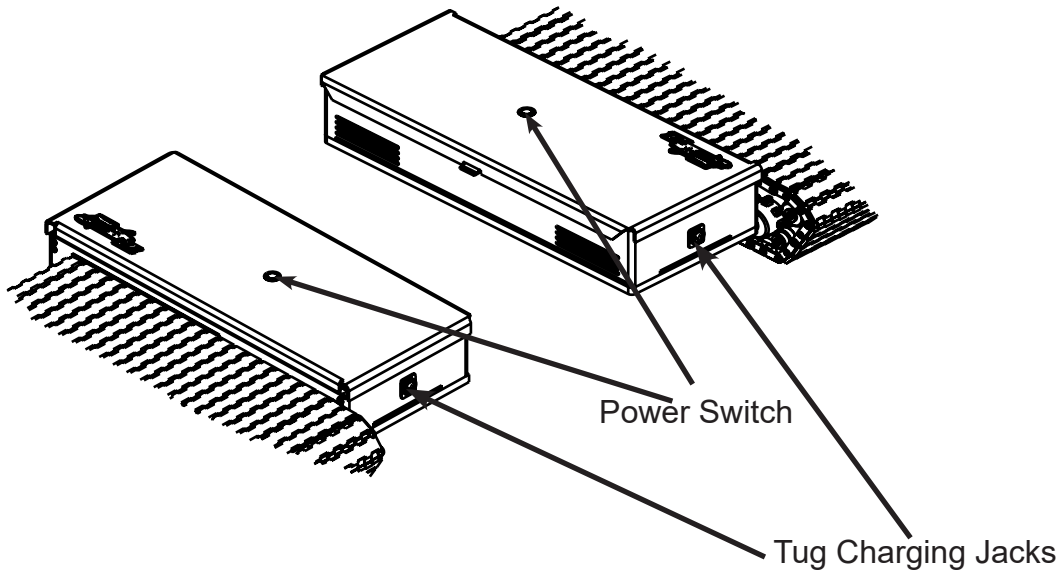

2. Plug charger into charging jack and into a wall socket. The plug can only be inserted in one direction.

3. Normal charger indicator lights:

Red.....Charging
Solid Green.....Fully Charged
Flashing Green.....No Longer Charging

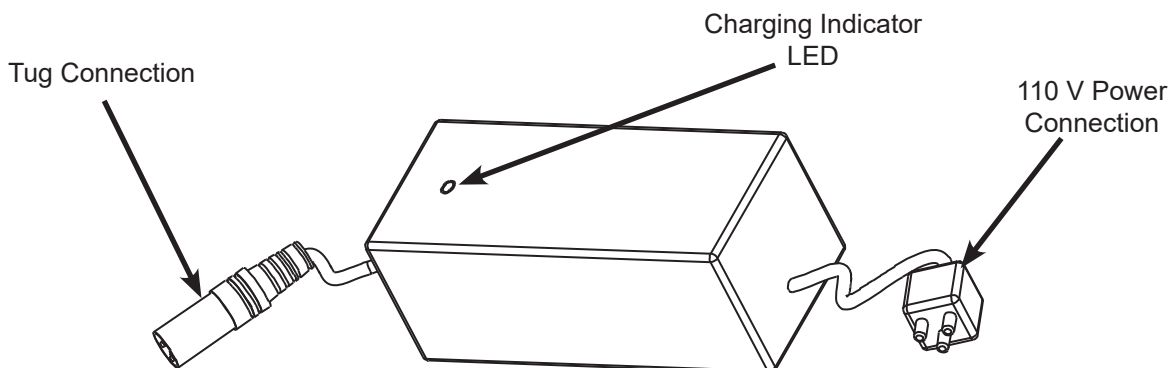

4. Leave the charger connected to the tug whenever the tug is not being used. The charger is a “smart” charger and this will prolong the life of the battery.

5-3. Charging the Transmitter

WARNING: Only use the supplied charger to charge the transmitter when using the supplied batteries or the following:

- 1200mAh to 2200 mAh Ni-MH or Ni-Cd 'AA' Rechargeable Batteries

The use of the transmitter charger with alkaline batteries installed can damage the transmitter. Do not use the charger if alkaline batteries are installed in the transmitter.

1. Plug the transmitter charger into a 110 V AC wall socket.
2. Plug the connector from the charger into the charging jack on the transmitter. The charging indicator LED, located on the side of the transmitter, will illuminate green indicating the charger is charging. Once the transmitter is fully charged the charging indicator LED will turn off. The charging rate of the charger is 150mAh.
3. When using the 1200mAh batteries that are supplied, the radio requires an 8 hour charge when fully discharged ($1200/150=8$). If using 2200mAh batteries, it will take approximately 15 hours to charge ($2200/150=14.6$).

It is recommended to leave the transmitter charging when not in use

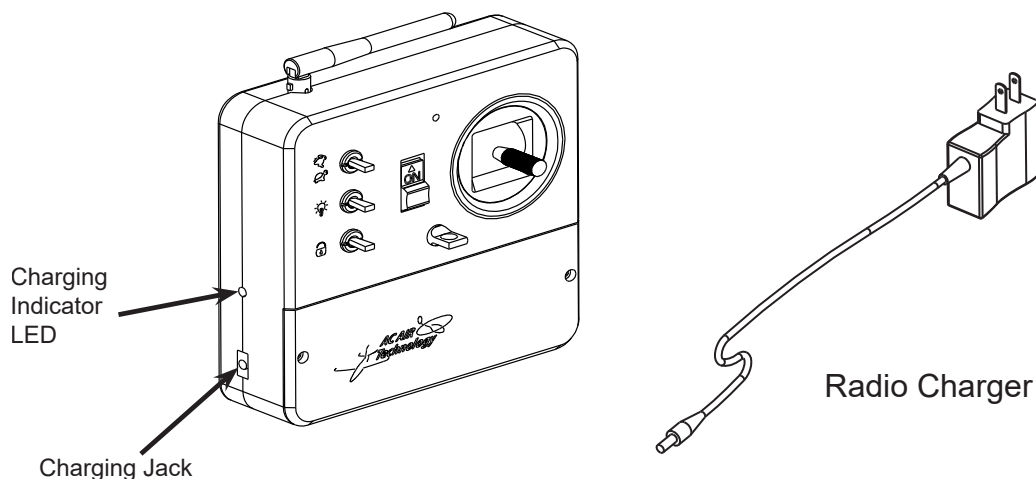

5-4. Replacing Radio Batteries

1. Before changing the radio transmitter batteries, be sure the radio transmitter and tug are both turned OFF.
2. Remove the 2 screws on the back cover of the radio transmitter then remove the back cover.

Note: Do not remove the front cover (with etched logo).

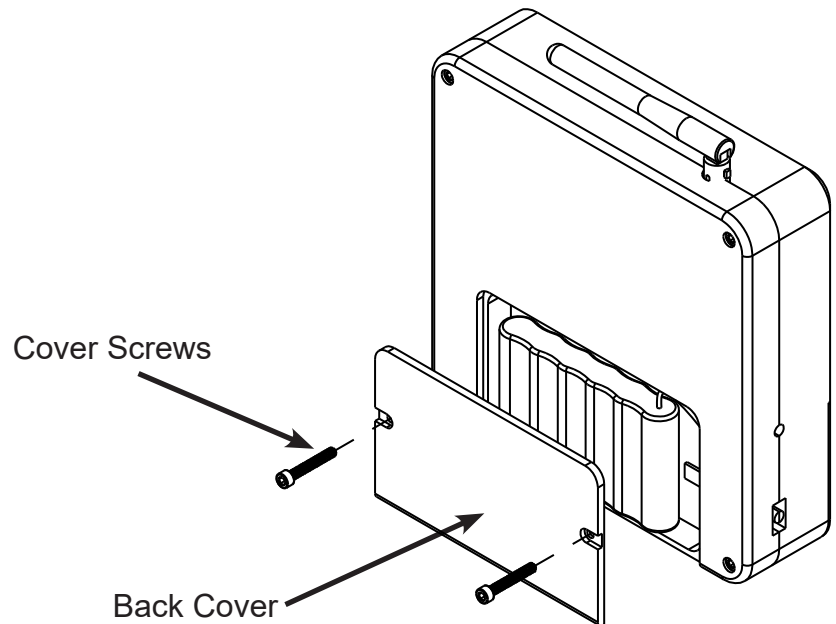
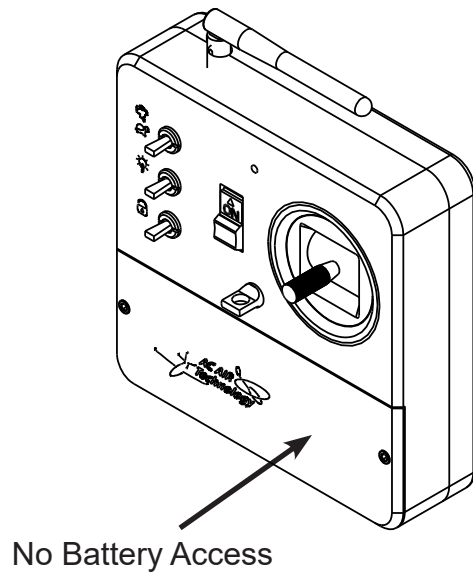

The transmitter batteries are set up like A or B shown below:

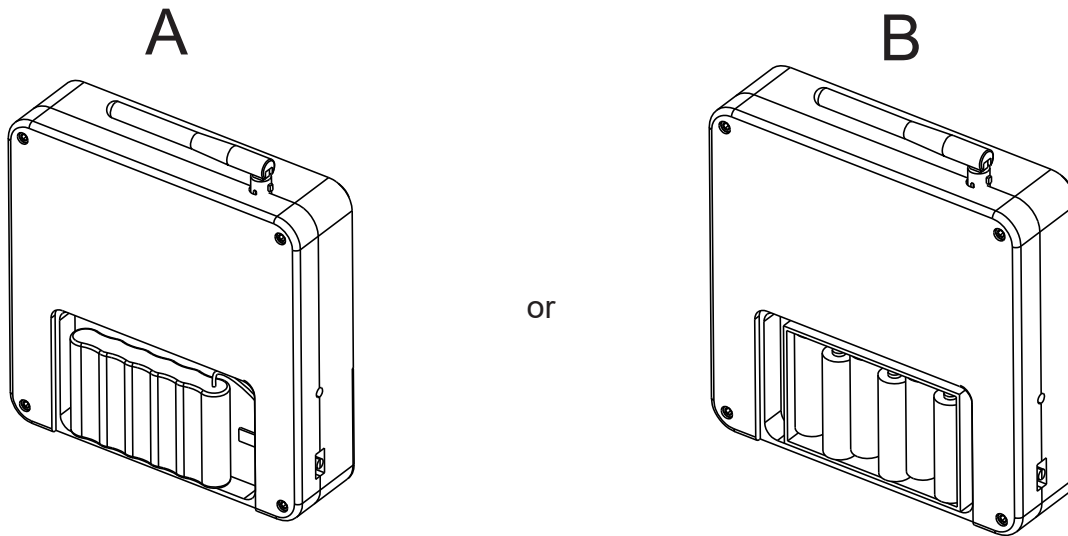

A. A shrink wrapped battery pack

3A. Disconnect the shrink wrapped battery pack and remove the battery.

4A. Replace the batteries by purchasing a new shrink wrapped battery pack from AC Air Technology or installing the supplied battery tray and purchasing 6 rechargeable 'AA' Lithium Ion batteries. Refer to section 2-9 in the owners manual

5A. Reconnect the battery to the transmitter circuit board.

6A. Re-install back cover and screws.

B. A battery tray with 6 rechargeable 'AA' Lithium Ion batteries

3B. Remove the 6 batteries and replace with new rechargeable 'AA' Lithium Ion batteries. Refer to section 2-9 in the owners manual.

Note: A shrink wrapped battery pack can be purchased from AC Air Technology to replace the installed battery tray. To use a shrink wrapped battery pack:

1. Disconnect the battery tray from the transmitter circuit board.
2. Connect the new shrink wrapped battery pack to the circuit board.

4B. Re-install back cover and screws.

Battery Tray

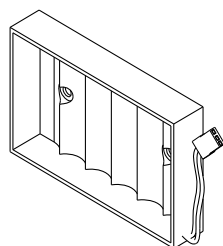

6. Troubleshooting

For technical support call or e-mail

AC Air Technology
(855) 884-7222
info@acairtechnology.com

WARNING: DO NOT SIT IN THE HELICOPTER WHILE OPERATING THE TUG.

TO PREVENT GOING BEYOND THE WIDTH LIMITS OF YOUR HELICOPTER SKIDS ENSURE TO MEASURE THE WIDTH ACCURATELY. BELOW ARE A FEW WAYS TO DO SO BUT ULTIMATELY IT IS AT THE OPERATORS DISCRETION AND LIABILITY TO PROPERLY LOAD THE HELICOPTER. ANY DAMAGE INCURRED AS A RESULT OF FAILING TO PROPERLY MEASURE THE SKIDS WIDTH IS SOLELY THE RESPONSIBILITY OF THE TUG OPERATOR. IT IS THE TUG OPERATORS RESPONSIBILITY TO ALSO KEEP A VISUAL ON THE SKIDS WHEN LOADING THE HELICOPTER. IMMEDIATELY REVERSE AND DO NOT ATTEMPT TO LOAD THE HELICOPTER IF THE SKIDS BEGIN TO BE STRETCHED BEYOND THEIR LIMITS.

WARNING: DO NOT PUT ANY PART OF YOUR BODY IN THE ROLLERS, SEVERE BODILY INJURY CAN OCCUR.

Tug			
Symptom	Cause	Action	Detail
Tug beeps 3 times	Tug is ON	No action required	Tug will beep when initially turned on
	Battery voltage is getting low	Charge tug battery	Tug charger indicator light will illuminate red when charging and green when fully charged. Tug will beep when the battery voltage is below 28 volts (power button flashing red). It is recommended to keep the tug and remote controller charging when not in use .
	Tug is momentarily overloaded	Turn the tug power button OFF then ON again to reset the PC Board.	Steep inclines, turning the tug underneath the wheel without any forward/backward motion, and sudden stops can cause the tug to signal a momentary overload.
Tug beeps continuously	Battery voltage is below operable voltage	Charge tug battery or Replace battery if it does not hold a charge With a voltmeter, check tug charger output voltage for 29.4 volts. Replace charger if it does not output the correct voltage	Tug power button light will blink red. Tug charger indicator light will illuminate red when charging and green when fully charged. It is recommended to keep the tug and remote controller charging when not in use .
Tug indicates a full charge soon after it is plugged into the charger	Charger has failed	Replace tug charger	Tug charger indicator light will illuminate red when charging and green when fully charged
Tug does not turn on	Battery is not plugged into the PC Board	Turn off the remote controller and tug. Open the magnetic tug cover and plug the battery into the PC board. Ensure the connection is fully engaged.	During shipping the battery connection can become loose or disengage from the PC board.
	Battery voltage is below operable voltage	Charge tug battery or Replace battery if it does not hold a charge With a voltmeter, check tug charger output voltage for 29.4 volts. Replace charger if it does not output the correct voltage	Tug charger indicator light will illuminate red when charging and green when fully charged. It is recommended to keep the tug and remote controller charging when not in use .
	Main board 10-amp fuse is blown	Replace the 10-amp fuse.	The provided spare parts kit comes with extra fuses. It includes a 4-amp fuse (lights) and 10-amp fuse (main board). These are common fuses that can be found at most auto parts stores. Disconnect the battery when working on or around the PC board to prevent a short circuit.
Tug does not respond to remote controller	Battery is low on remote controller or tug	Charge the battery on remote controller or tug	Tug charger indicator light will illuminate red when charging and green when fully charged. Remote controller charging indicator light, located on the side of the remote, will illuminate

			<p>green when charging and light will turn off then fully charged.</p> <p>It is recommended to keep the tug and remote controller charging when not in use.</p>
	Tug is overloaded	<p>Reset the circuit breaker(s). Turn off the remote controller and tug. Open the magnetic tug cover and locate the circuit breaker(s) on the PC board. Press the button(s) down to deactivate the circuit breaker (If it is active you will feel some resistance from the button). See the critical note in the "Details" section.</p>	<p>Steep inclines, towing above the tug's capacity, and sudden stops can cause the tug to activate the circuit breaker.</p> <p>CRITICAL NOTE: If the circuit breaker continues to activate after being reset, the tug is being overstressed and could cause damage to the circuit board. Address any mechanical issues, such as a seized sprocket or missing track retainer clips or any driving conditions, such as driving up a steep incline or towing above the tugs capacity that could cause the tug to overstress. If the issue persists, call or email AC Air Technology tech support for further assistance.</p>
	Remote controller and receiver are not binding	Rebind remote controller and receiver.	Call or email tech support for further assistance
One track turns but the other track does not	Speed controls are not plugged into radio receiver correctly	<p>Turn off the radio controller and tug. Open the magnetic tug cover. Visually inspect the wire from the speed control to the receiver on the PC board for any damage. If there is damage, replace the speed controls.</p> <p>Verify that the wires from the speed controls are connected to slot numbers 1 and 2 on the receiver. Ensure the connections are fully engaged</p>	If there is damage to the speed controls, the PC board may need to be replaced. Call tech support for further assistance.
	Gearbox failure	<p>Open the tug cover and visually inspect the motors for any obstruction. With the radio off, carefully clear any obstruction.</p> <p>With the cover open, radio on, visually check if the motor(s) are turning. If the motor(s) are turning but the track is not, the gearbox needs repair.</p>	Call or email tech support for further assistance
Tug operating sluggish/ low power	Tug is being operated on LOW or MEDIUM Speed.	Switch speed setting on remote controller to HI speed. (Rabbit Icon)	HI speed mode enables the tug's full power. It is recommended to use the tug in HI speed mode when operating outside, in an open area. LOW and MEDIUM speed modes are helpful when operating in small quarters for precise positioning.

Remote Controller			
Symptom	Cause	Action	Detail
Remote controller is beeping	Battery is low	Charge remote controller or replace remote controller batteries	See owner's manual section "Replacing Transmitter Batteries" for details It is recommended to keep the tug and remote controller charging when not in use
Remote controller does not turn ON	Battery voltage is below operable voltage	Charge remote controller or replace remote controller batteries	See owner's manual section "Replacing Transmitter Batteries" for details It is recommended to keep the tug and remote controller charging when not in use
Remote controller indicates a full charge soon after it is plugged into the charger	Charger has failed	Replace remote controller charger	The remote controller LED on the left side of the controller, just above the charging port, will illuminate green to indicate it is charging. The green will turn OFF once it is fully charged.
Remote Controller long-beep sound, tug is ON but the does not respond to remote controller	Joystick connection is loose	Remove remote control <i>back</i> cover which is held on with 4 screws. Disconnect and reconnect the joystick.	Do not forget to reconnect the remote-control battery.
	Joystick needs to be recalibrated	To verify issue, remove remote control <i>front</i> cover which is held on with 2 screws. Turn the remote off then back on <i>without</i> moving the joystick, the screen will read "Throttle Warning"	Call or email tech support for further assistance

Roller Cradle			
Symptom	Cause	Action	Detail
Unable to change the rollers from "Lock" to "Engaged" or from "Engaged" to "Locked"	The internal clutch is not moving enough	Slowly move the tug forward and backward until you see both rollers doing the proper movement.	It may take several times of back and forth movements to get the rollers to engage or lock.
	Servo is not plugged in	Turn off the remote controller and tug. Open the magnetic tug cover. The servo is located under the track, follow the wire to the radio receiver, located on the PC Board, and verify it is connected to slot number 6 on the radio receiver. Ensure the connection is fully engaged	It may be necessary to remove the track in order to see the servo motor.
	Servo failure	Use the Engage/Lock switch on the remote control, if no sound or motion is coming from the servo, the servo needs to be replaced	It may be necessary to remove the track in order to access the servo motor.

7. Warranty

LIMITED WARRANTY

Your new AC Air Technology Tug is warranted to the original purchaser (only) for one full year from the date of purchase to be free from factory defects in material and workmanship. During this 12-month period, AC Air Technology will repair or replace, at our discretion, the defective component determined by AC Air Technology to be defective.

This warranty does not apply to damage or defect resulting from misuse, improper application, commercial use, or attempted repair by “non-AC Air Technology” service staff. The warranty does not cover shipping or handling cost or any incidental or consequential damage. Batteries and tracks are not covered by warranty.

DAMAGE LIMITS

AC Air Technology shall not be liable for any damage, indirect or consequential, loss of profits or commercial or production loss, or other special loss or damage in any way connected with this product regardless whether such claim is based on warranty, in contract, negligence, or strict liability. In no event shall the liability of AC Air Technology exceed the individual price of the product on which liability is asserted. AC Air Technology has no control of the set up, application, use, modification, or misuse of this product, thus no liability shall be assumed or accepted for any resulting damage or injury. By the first act of use, set up or assembly, the user in using the product accepts all resulting liability. Failure to operate this product in a safe and responsible manner can result in damage or injury, both to the user as well as to others, the product, or property. This product is not a toy and is NOT intended to be used by children without adult supervision. It is essential to read the entire manual and warranty/liability information prior to first use/application/installation of this product to operate correctly and avoid damage/injury,

In cases where the purchaser or user are not prepared to accept liability associated with the use of this product, the user or purchaser is advised to return the unused product immediately in unused condition to the place of purchase.

RETURN PROCEDURE

When sending equipment in for requested warranty service, please include a note describing the problems/concerns with the equipment. You must include your name, address, telephone number and e-mail for prompt service. To request warranty service, a copy of your original sales receipt must be included. Warranty is approved and performed at the discretion of AC Air Technology service department. You are required to pay all postage, shipping and insurance charges.

RETURN POLICY

Products can be returned within 10 days of delivery for a full refund if the product is in new condition and shipped with all the original packing and accessories. Any shipping cost associated with product delivery and/or return will not be refunded. A return authorization must be requested from AC Air Technology before any products can be returned.