

1. Components

2. Start-Up Guide

3. Warranty

1. Components

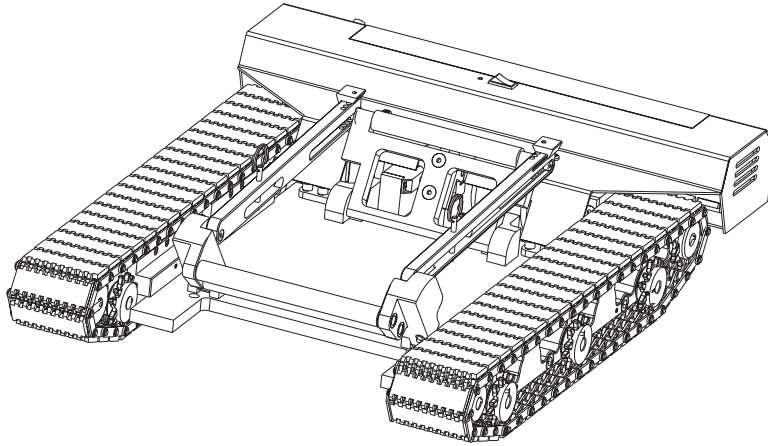

Tug

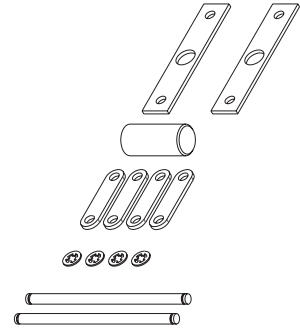

Track Replacement Kit

2. Start Up Guide

1. Remove battery cover and motor cover by removing 6 torx screws. Note: Some models need plug jack retaining nut removed to remove motor cover.

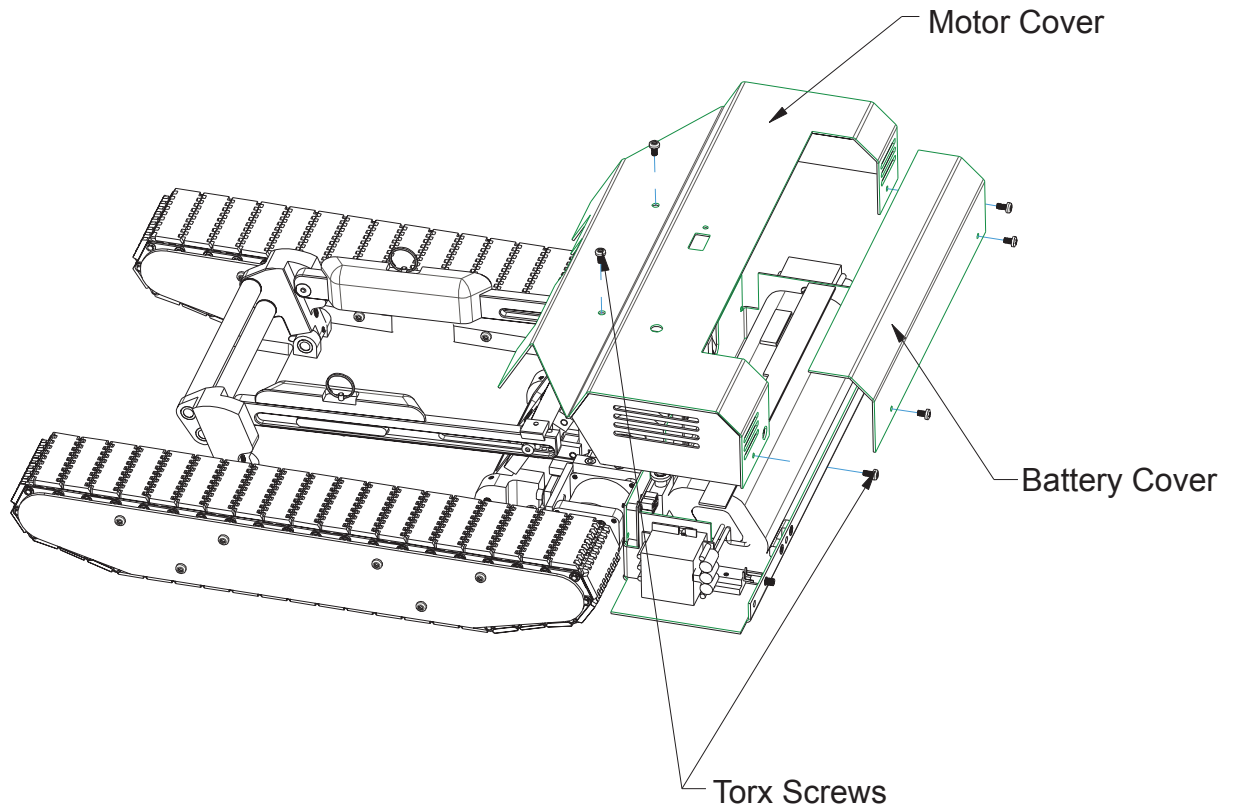

2. Remove all 4 plastic track guards by removing several Torx screws.

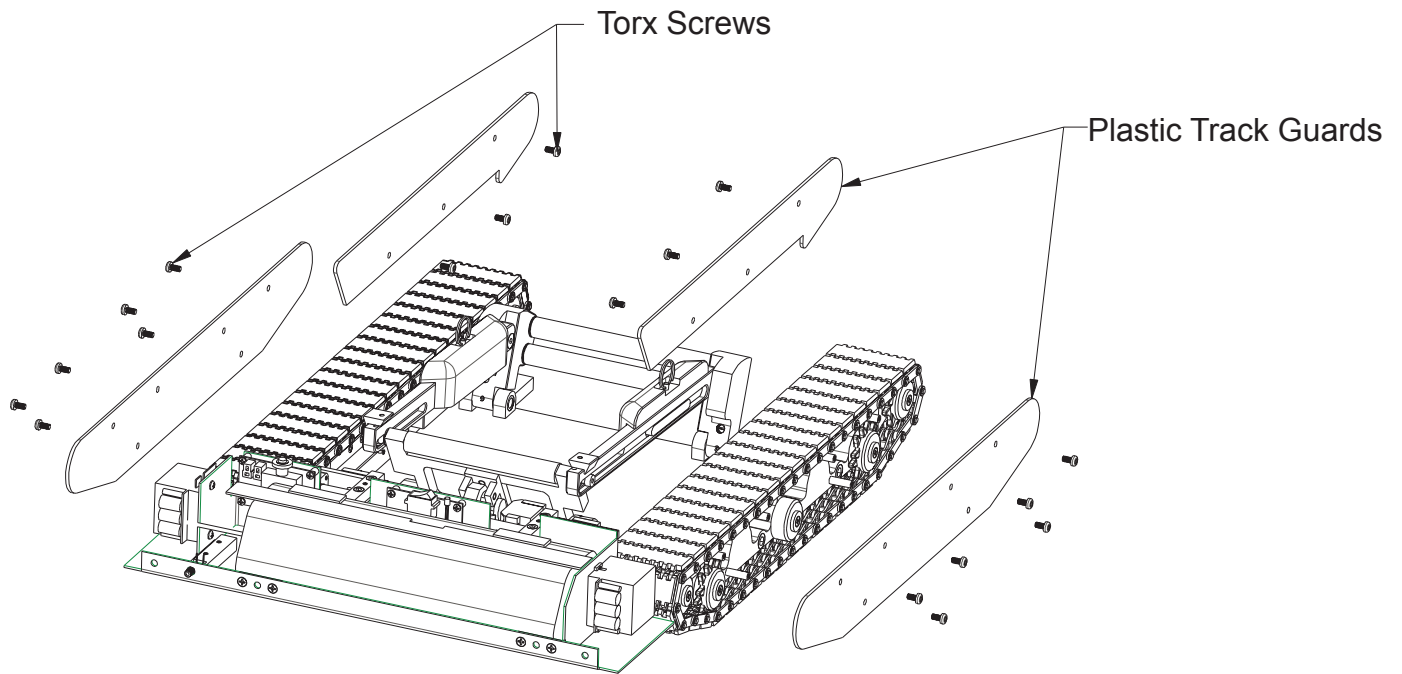

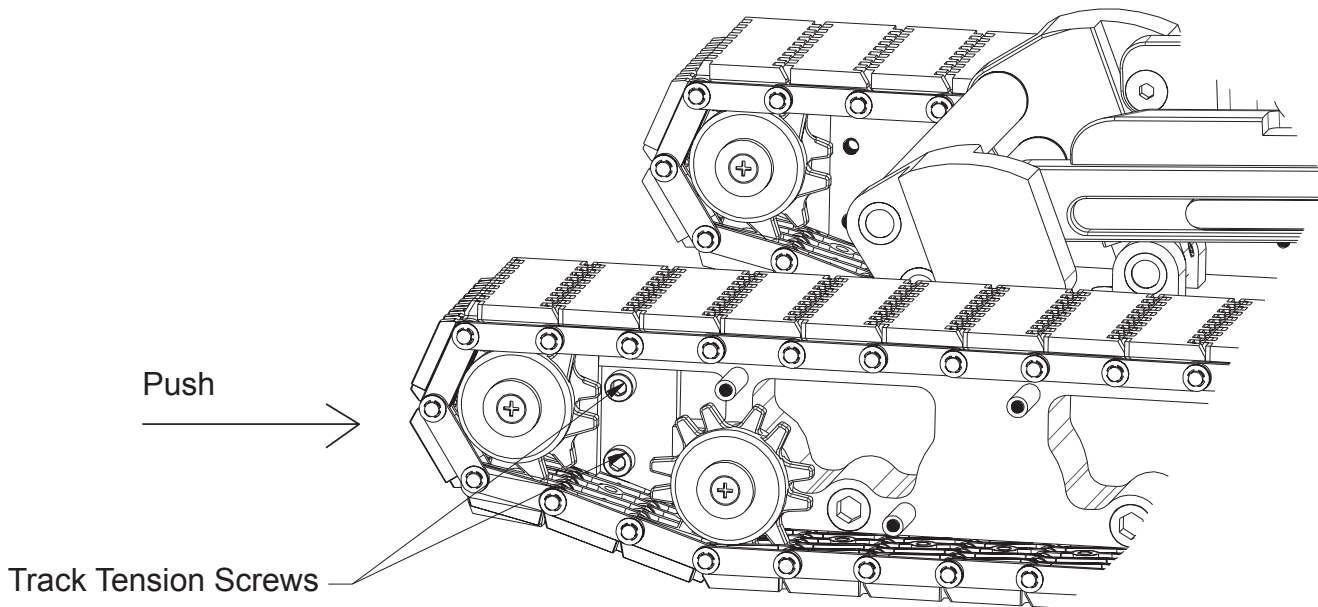

3. Loosen the track tension screws on track you are removing. Push the front of the track inward to compress the springs and loosen the tracks. Re-tighten the track tension screws with springs compressed.

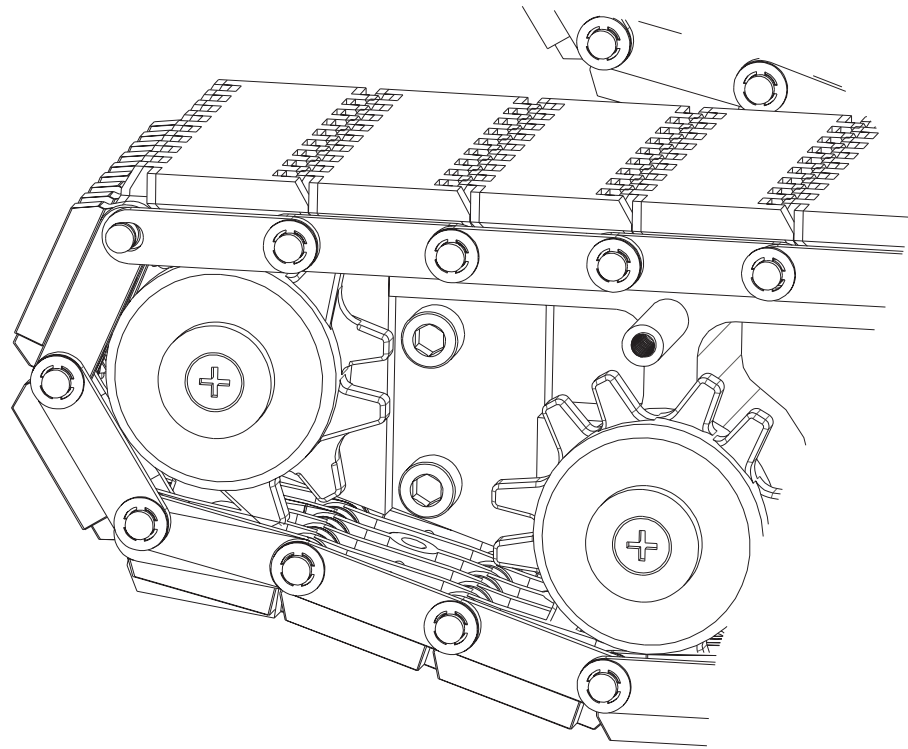

4. Remove one of the outer retainer clips from the track you are removing. Note: The retaining clip can be cut off with side cutters and discarded.

Retainer Clip



5. Remove the track pin from the track and then remove the entire track from the tug.

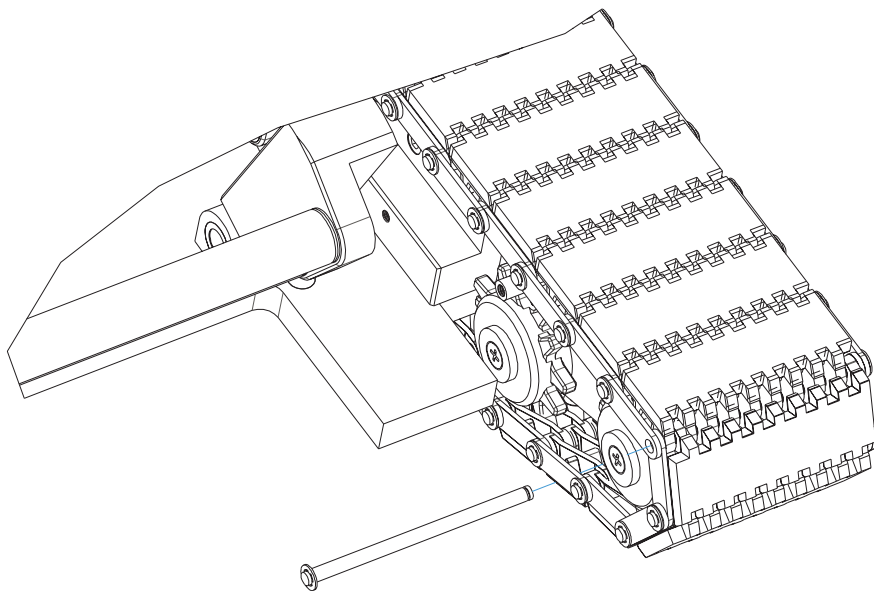

6. Place the new track on the tug with the break at the front of the rail as shown below.

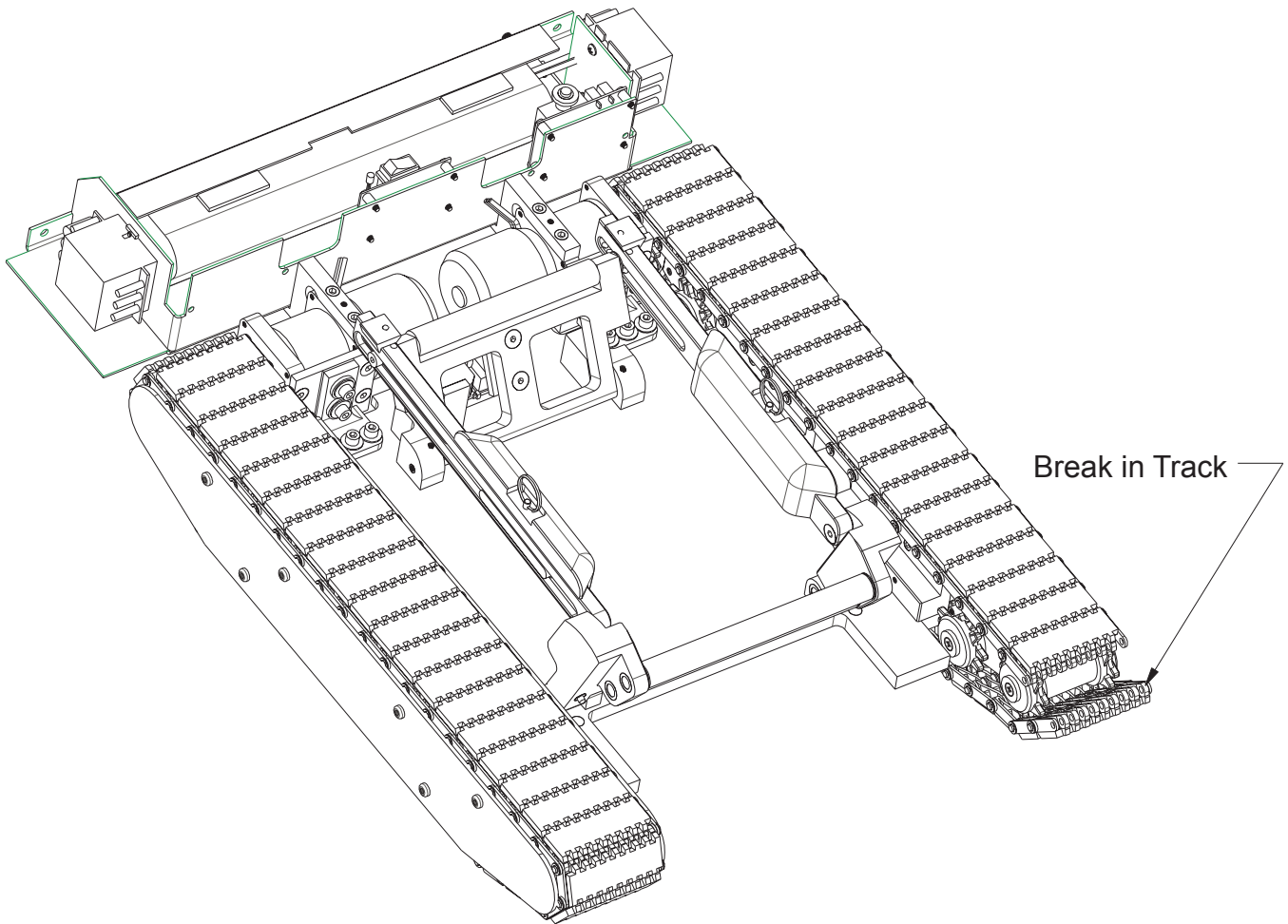

7. Put track install tool (part #22844) on outside and inside track pins adjacent to break. **Note: You may need to hold the tools in place on the pins.**

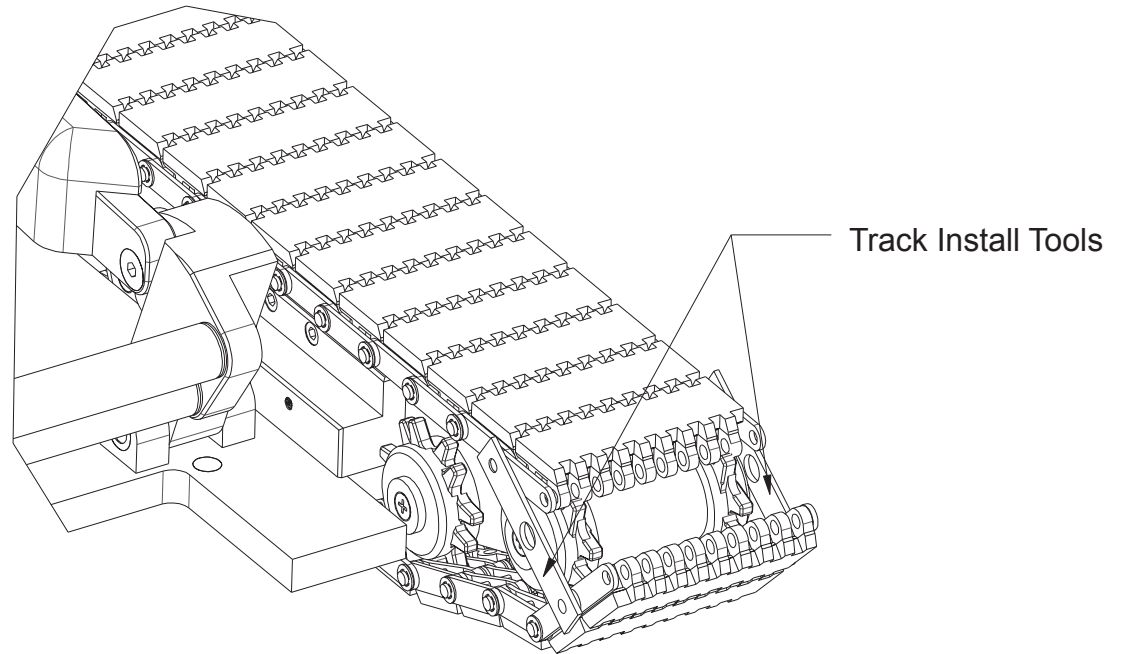

8. Rotate motor by hand to move the break in the track back to the straight part of the rail while holding tools on the pins. **Warning: Do not turn on the power at any point of this process.**

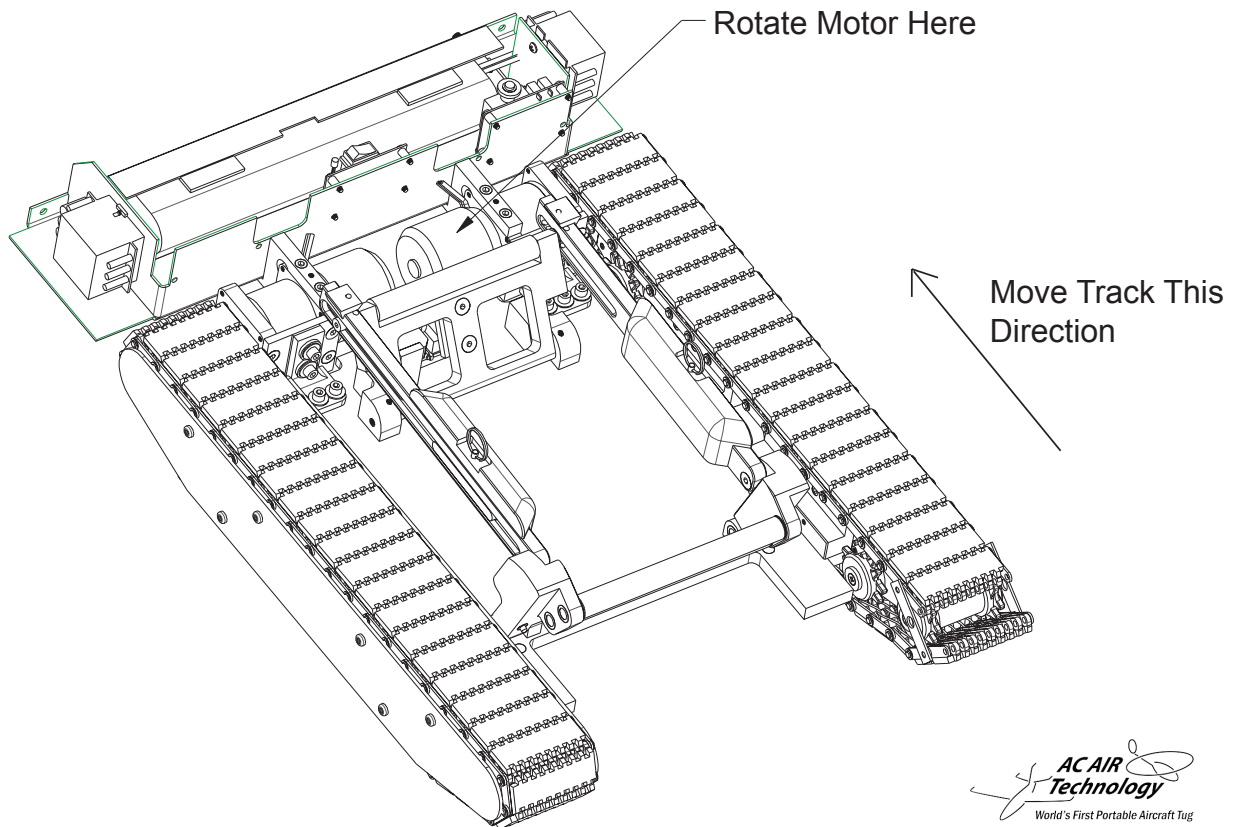

9. Line - up track holes and insert the track pin thru to other side.

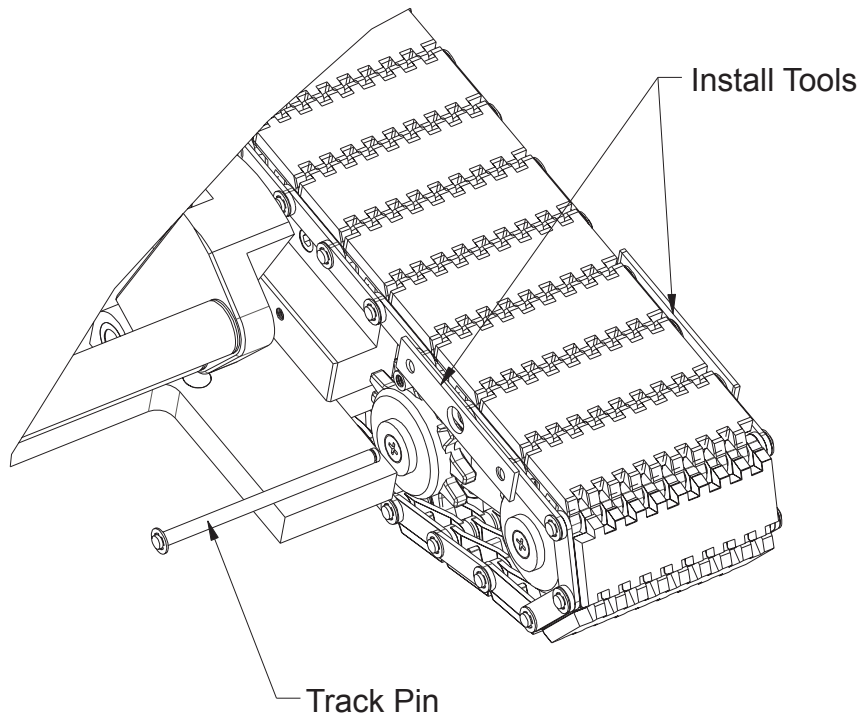

10. Insert new retainer clip on the end of the track pin. Use the retainer clip tool and tap it with a hammer while pressing on other end of the track pin with something to keep the pin from moving. **Note: The retainer clip must be installed with the small teeth angled outward.**

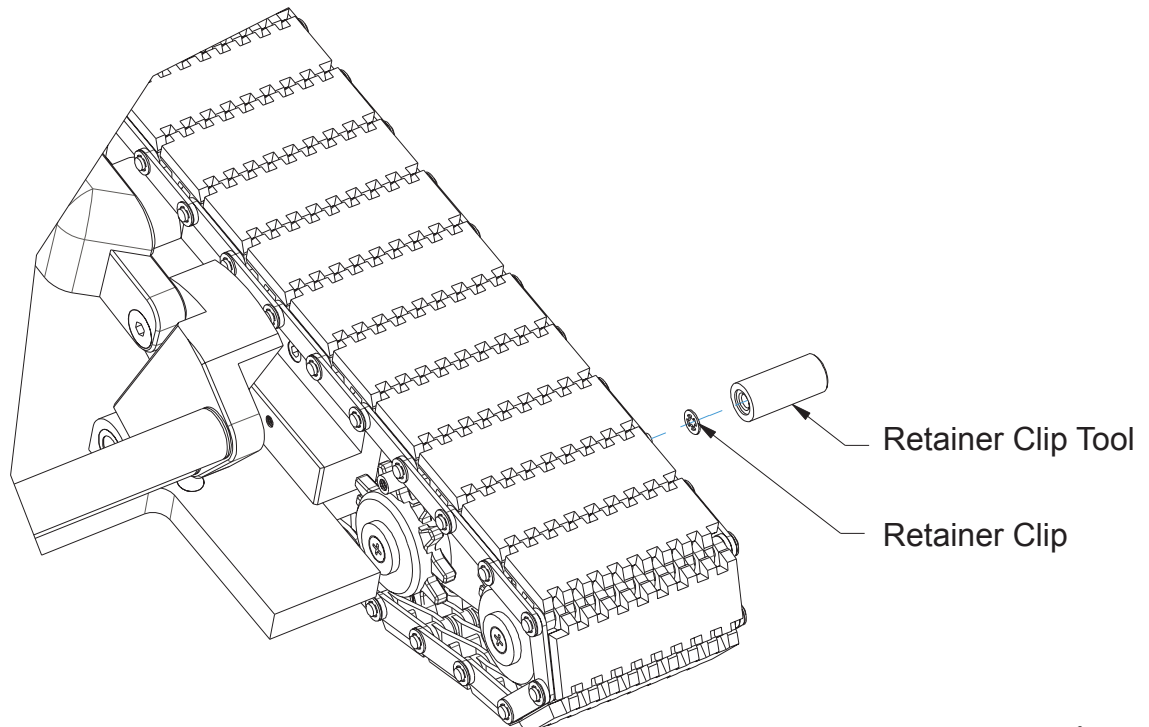

11. Re-install plastic track guards, motor cover, and battery cover.

3. Warranty

LIMITED WARRANTY

Your new AC Air Technology Tug is warranted to the original purchaser (only) for one full year from the date of purchase to be free from factory defects in material and workmanship. During this 12-month period, AC Air Technology will repair or replace, at our discretion, the defective component determined by AC Air Technology to be defective.

This warranty does not apply to damage or defect resulting from mis-use, improper application, commercial use, or attempted repair by “non-AC Air Technology” service staff. The warranty does not cover shipping or handling cost or any incidental or consequential damage. Batteries and tracks are not covered by warranty.

DAMAGE LIMITS

AC Air Technology shall not be liable for any damage, indirect or consequential, loss of profits or commercial or production loss, or other special loss or damage in any way connected with this product regardless whether such claim is based on warranty, in contract, negligence, or strict liability. In no event shall the liability of AC Air Technology exceed the individual price of the product on which liability is asserted. AC Air Technology has no control of the set up, application, use, modification, or misuse of this product, thus no liability shall be assumed or accepted for any resulting damage or injury. By the first act of use, set up or assembly, the user in using the product accepts all resulting liability. Failure to operate this product in a safe and responsible manner can result in damage or injury, both to the user as well as to others, the product, or property. This product is not a toy and is NOT intended to be used by children without adult supervision. It is essential to read the entire manual and warranty/liability information prior to first use/application/installation of this product to operate correctly and avoid damage/injury,

In cases where the purchaser or user are not prepared to accept liability associated with the use of this product, the user or purchaser is advised to return the unused product immediately in unused condition to the place of purchase.

RETURN PROCEDURE

When sending equipment in for requested warranty service, please include a note describing the problems/concerns with the equipment. You must include your name, address, telephone number and email for prompt service. To request warranty service, a copy of your original sales receipt must be included. Warranty is approved and performed at the discretion of AC Air Technology service department. You are required to pay all postage, shipping and insurance charges.