



1. Components

2. Installation Guide

2-1. Initial Setup

2-2. Loading

2-3. Warranty

1. Components

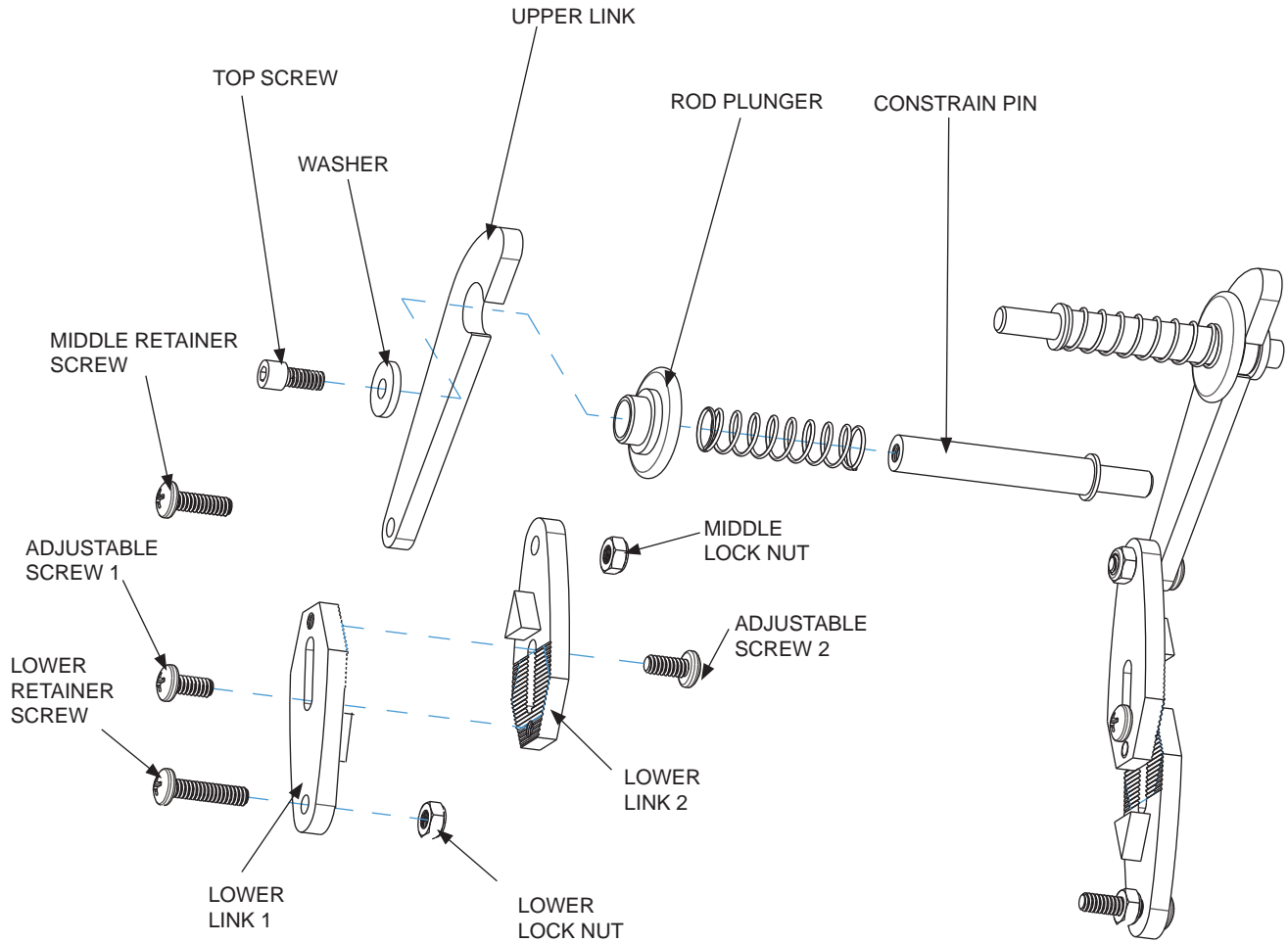

2. Installation Guide

2-1. Initial Setup

1. Assemble both Constrain Bar Assemblies to the outside of both rails using the Lower Retainer Screws and Lower Lock Nuts.

NOTES:

1. Triangle shape on Lower Links need to be pointed toward the center of the tug.
2. Leave Lower Lock Nuts slightly loose to allow Lower Link to rotate freely.
3. Cutout on Upper Links need to be facing towards the front of the tug.

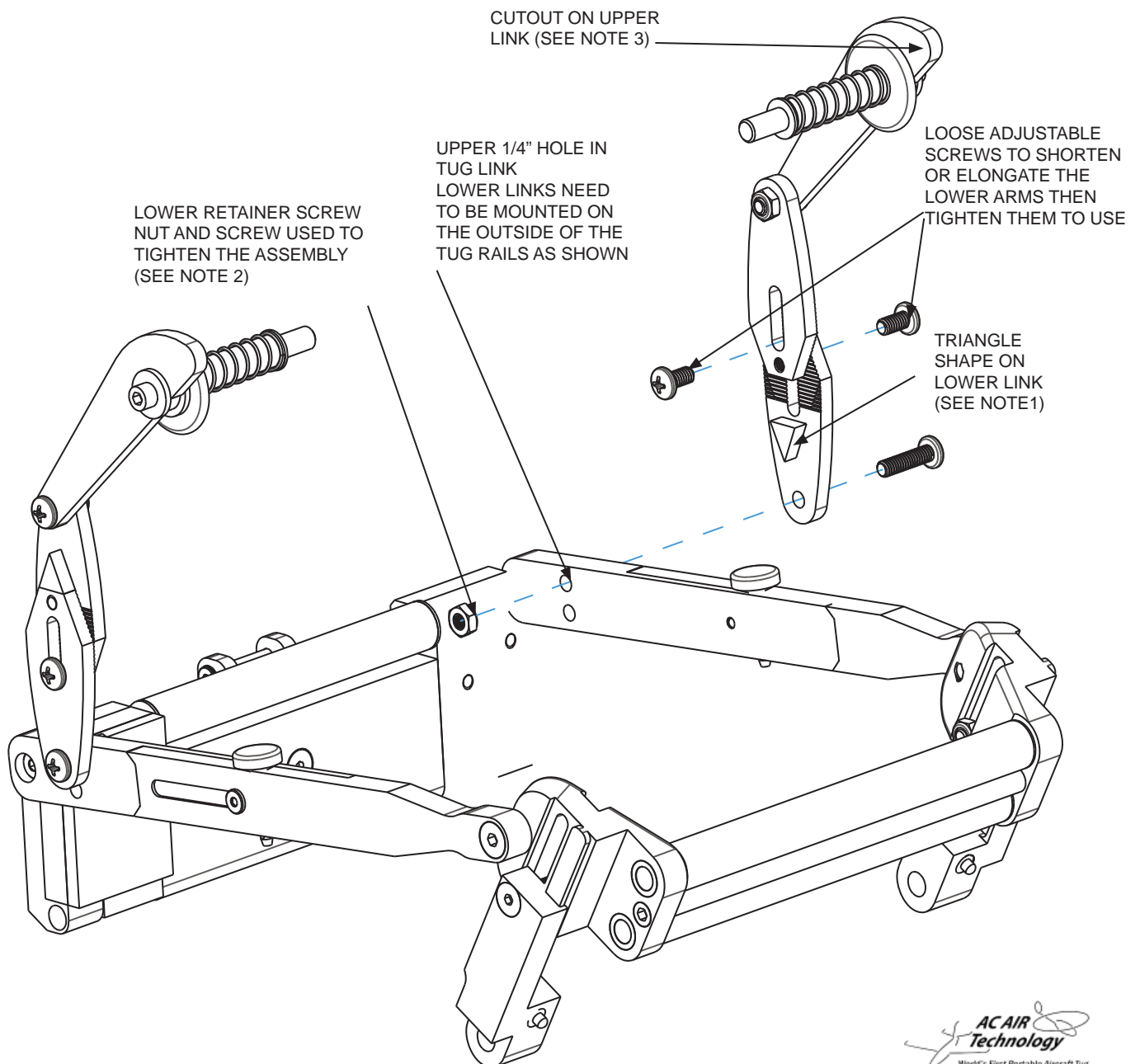

2. Installation Guide

2-2. Loading

Note: Initial setup needs to be performed one time before following these steps.

1. Fold Constrain Bar Assemblies down as shown in diagram. Lower wheel ramp and remove both constraint Plunger Assemblies.

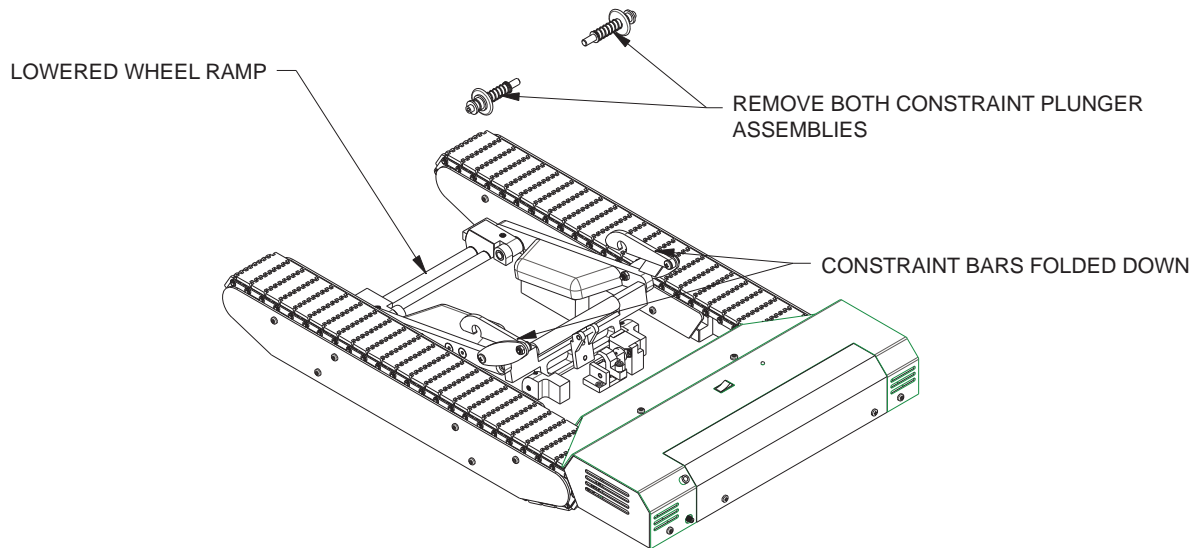

2. Load the front wheel of the plane onto the tug with the wheel ramp in the full up position.

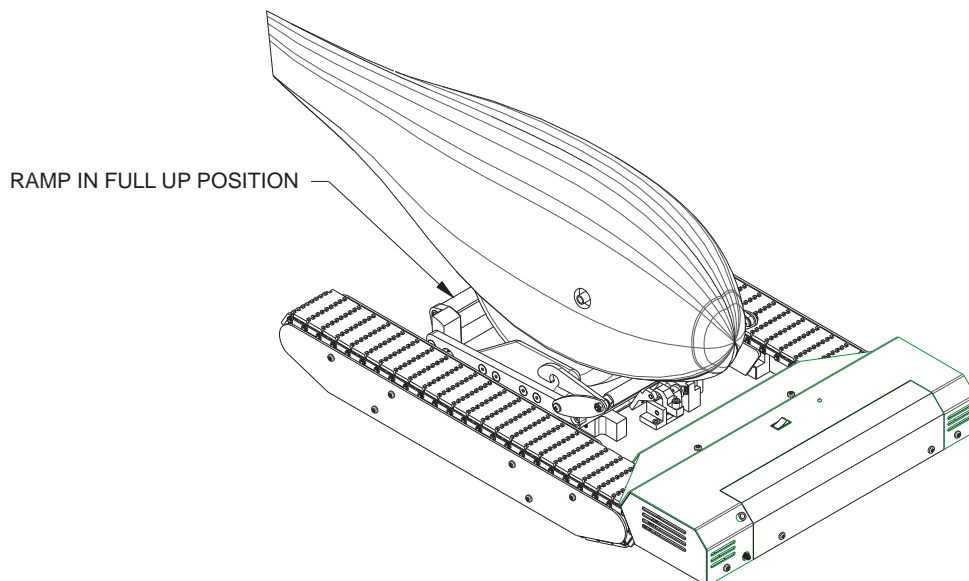

3. Insert the Constrain Pin end of the Constrain Plunger Assembly into the mounting hole on the side of the wheel pant. Then compress the spring and rotate the Constrain Bar up to insert the cutout on the Upper Link onto the Constrain Pin, release the spring to engage the Rod Plunger into the Upper Link.

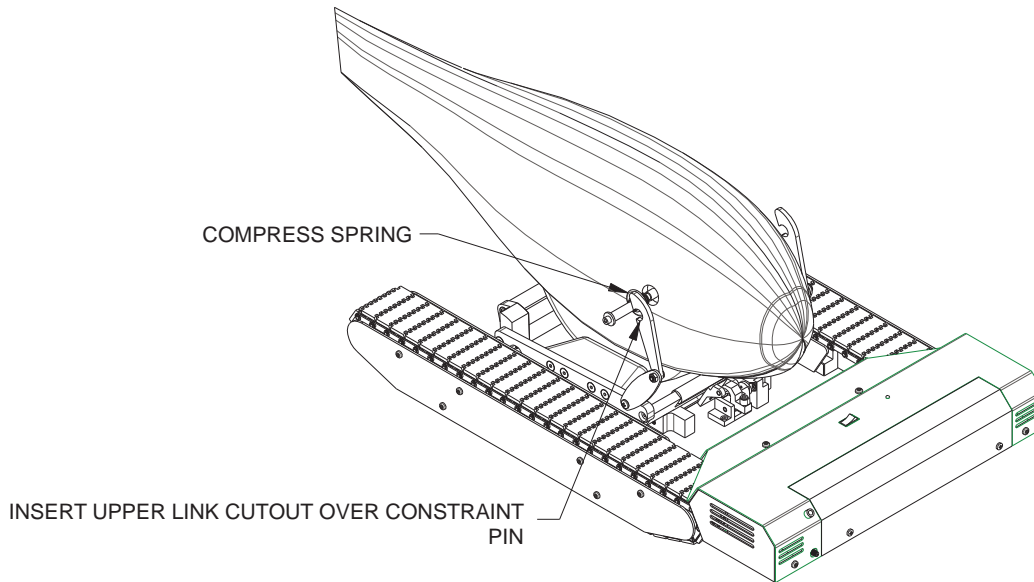

4. Repeat steps for the Constrain Bar on the other side of the wheel pant.

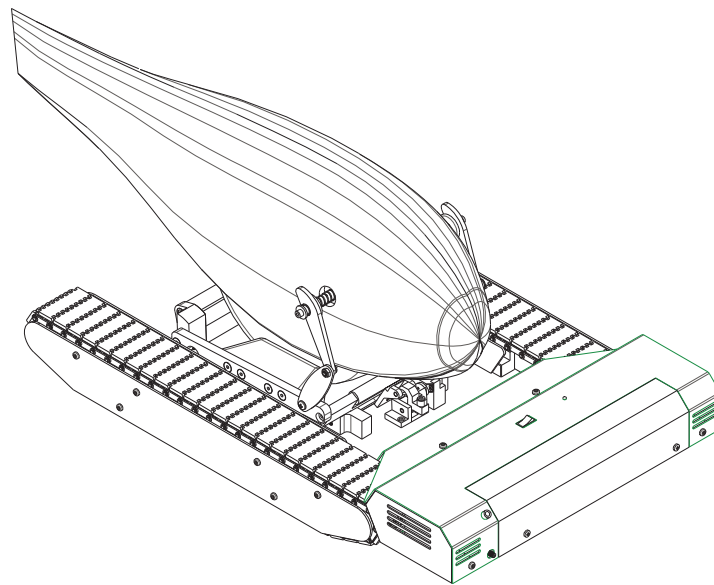

5. To unload the plane just reverse the steps used during loading.

2-3. Warranty

LIMITED WARRANTY

Your new AC Air Technology Tug is warranted to the original purchaser (only) for one full year from the date of purchase to be free from factory defects in material and workmanship. During this 12-month period, AC Air Technology will repair or replace, at our discretion, the defective component determined by AC Air Technology to be defective.

This warranty does not apply to damage or defect resulting from mis-use, improper application, commercial use, or attempted repair by “non-AC Air Technology” service staff. The warranty does not cover shipping or handling cost or any incidental or consequential damage. Batteries and tracks are not covered by warranty.

DAMAGE LIMITS

AC Air Technology shall not be liable for any damage, indirect or consequential, loss of profits or commercial or production loss, or other special loss or damage in any way connected with this product regardless whether such claim is based on warranty, in contract, negligence, or strict liability. In no event shall the liability of AC Air Technology exceed the individual price of the product on which liability is asserted. AC Air Technology has no control of the set up, application, use, modification, or misuse of this product, thus no liability shall be assumed or accepted for any resulting damage or injury. By the first act of use, set up or assembly, the user in using the product accepts all resulting liability. Failure to operate this product in a safe and responsible manner can result in damage or injury, both to the user as well as to others, the product, or property. This product is not a toy and is NOT intended to be used by children without adult supervision. It is essential to read the entire manual and warranty/liability information prior to first use/application/installation of this product to operate correctly and avoid damage/injury,

In cases where the purchaser or user are not prepared to accept liability associated with the use of this product, the user or purchaser is advised to return the unused product immediately in unused condition to the place of purchase.

RETURN PROCEDURE

When sending equipment in for requested warranty service, please include a note describing the problems/concerns with the equipment. You must include your name, address, telephone number and email for prompt service. To request warranty service, a copy of your original sales receipt must be included. Warranty is approved and performed at the discretion of AC Air Technology service department. You are required to pay all postage, shipping and insurance charges.