

BILL OF MATERIAL (CURRENT LEVEL)

ITEM	PT/ASSY	DESCRIPTION	TYPE	QTY.
1	22422	TUG SHAFT RETAINER	PART	24
2	22646	T1.5 SPROCKET	PART	12
3	22836	T1.5 4" AXLE	PART	12
4	22915	T1.5 TRACK ROLLER	PART	4
5	22916	T1.5 TRACK ROLLER SHAFT	PART	4
6	22981	T1XB RAIL END RIGHT	PART	4
7	22982	T1XB RAIL END LEFT	PART	4
8	22996	DRIVE SPROCKET	PART	6
9	23338	T1X2 OUTSIDE RAIL PLATE	PART	2
10	23339	T1X2 INSIDE RAIL PLATE	PART	2
11	23341	T1X RAIL LONG TOP PLATE	PART	2
12	23490	INNER ROLLER SPACER	PART	8
13	23491	OUTTER ROLLER SPACER	PART	8
14	24288	T1X4 RAIL SUPPORT	PART	4
15	24352	TRANSMISSION SHAFT	PART	2
16	24499	T1X4 KNOB	PART	4
17	24500	T1X4 SPLUNGER	PART	4
18	24501	T1X4 WASHER	PART	4
19	24532	T1X4 DRIVE SPROCKET	PART	2
20	24535	T1X4 SLIDER PLATE	PART	4
21	91285	10-32 X 5/8" L SS FLAT HEAD	PART	2
22	92012	RAIL SPACER OD .54" ID .285"	PART	16
23	92325	10-24 X 3/8"L CAP SCREW	PART	4
24	92524	8-32"x.1" SET SCREW	PART	4
25	92699	.48 OD X .37" ID X 1" SPRING	PART	4
26	92700	5/32" X .5" SS DOWEL	PART	4
27	95025	1/2" BALL BEARING	PART	36
28	95026	1/8" SQ. X .400"L KEY STOCK	PART	20
29	95092	10-32 X 3/8"L FLAT HEAD	PART	24
30	95124	1/4"-20 X 1.5" L SOCKET CAP	PART	16
31	95200	1/4"-20 X 1"L SOCKET CAP	PART	16
32	95269	10-24 X 1"L SOCKET CAP	PART	8
33	95451	SHAFT CAP	PART	2
34	95544	10-32 X 3/8" CAP SCREW	PART	4
35	95658	1/4"-20 X 1/4" L CAP SCREW	PART	8
36	96294	TUG SPROCKET SPACER	PART	8

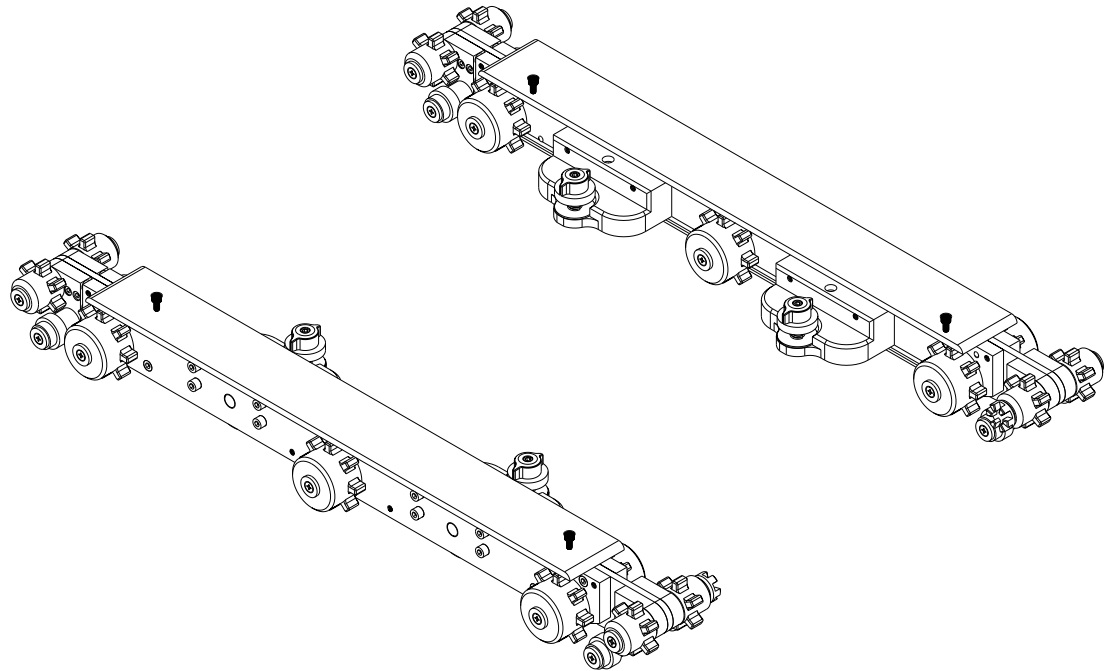

A Touch of Brass
A TOUCH OF BRASS INC

13832 MAGNOLIA AVE.
CHINO, CA 91710-7027
909-464-1000

T1X4 RAIL ASSEMBLY

DWG. NO. **09619**

REV
E

UNLESS OTHERWISE
SPECIFIED, DIMENSIONS
ARE IN INCHES.

SCALE **0.160**

APPR.

SHEET **1** OF **4**

BILL OF MATERIAL (CURRENT LEVEL)

ITEM	PT/ASSY	DESCRIPTION	TYPE	QTY.
1	24288	TIX4 RAIL SUPPORT	PART	4
2	24499	TIX4 KNOB	PART	4
3	24500	TIX4 SPLUNGER	PART	4
4	24501	TIX4 WASHER	PART	4
5	92524	8-32"x.1" SET SCREW	PART	4
6	92699	.48 OD X .37" ID X 1" SPRING	PART	4
7	92700	5/32" X .5" SS DOWEL	PART	4
8	95544	10-32 X 3/8" CAP SCREW	PART	4
9	95658	1/4"-20 X 1/4" L CAP SCREW	PART	8

 LOCTITE JOINT (GREEN)
 BLUE REMOVABLE LOCTITE

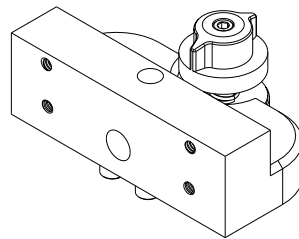
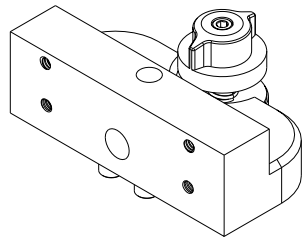
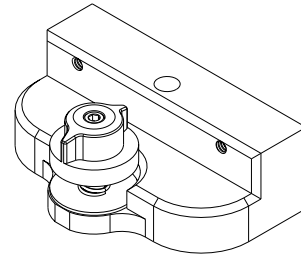
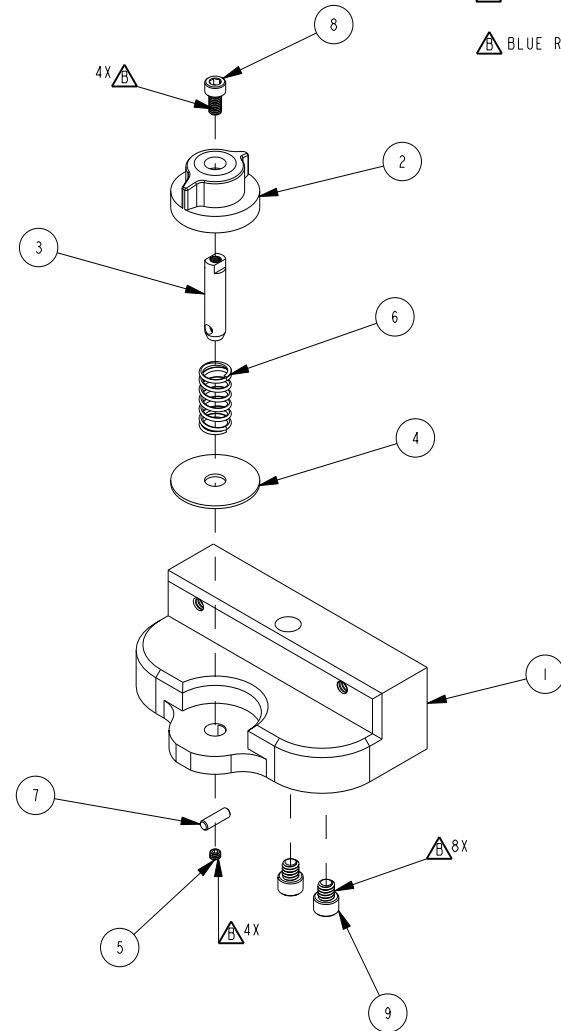

A Touch of Brass
A TOUCH OF BRASS INC

13832 MAGNOLIA AVE.
CHINO, CA 91710-7027
909-464-1000

TIX4 RAIL ASSEMBLY

DWG. NO. **09619**

REV E



UNLESS OTHERWISE SPECIFIED, DIMENSIONS ARE IN INCHES.

SCALE 0.350

APPR.

SHEET 2 OF 4

BILL OF MATERIAL (CURRENT LEVEL)				
ITEM	PT/ASSY	DESCRIPTION	TYPE	QTY.
1	22422	TUG SHAFT RETAINER	PART	12
2	22836	T1.5 4" AXLE	PART	6
3	22981	TIXB RAIL END RIGHT	PART	4
4	22982	TIXB RAIL END LEFT	PART	4
5	22996	DRIVE SPROCKET	PART	6
6	23490	INNER ROLLER SPACER	PART	8
7	23491	OUTTER ROLLER SPACER	PART	8
8	24352	TRANSMISSION SHAFT	PART	2
9	24532	TIX4 DRIVE SPROCKET	PART	2
10	24535	TIX4 SLIDER PLATE	PART	4
11	91285	10-32 X 5/8" L SS FLAT HEAD	PART	2
12	95025	1/2" BALL BEARING	PART	16
13	95026	1/8" SQ. X .400"L KEY STOCK	PART	8
14	95092	10-32 X 3/8"L FLAT HEAD	PART	12
15	95269	10-24 X 1"L SOCKET CAP	PART	8
16	95451	SHAFT CAP	PART	2

 LOCTITE JOINT (GREEN)
 BLUE REMOVABLE LOCTITE

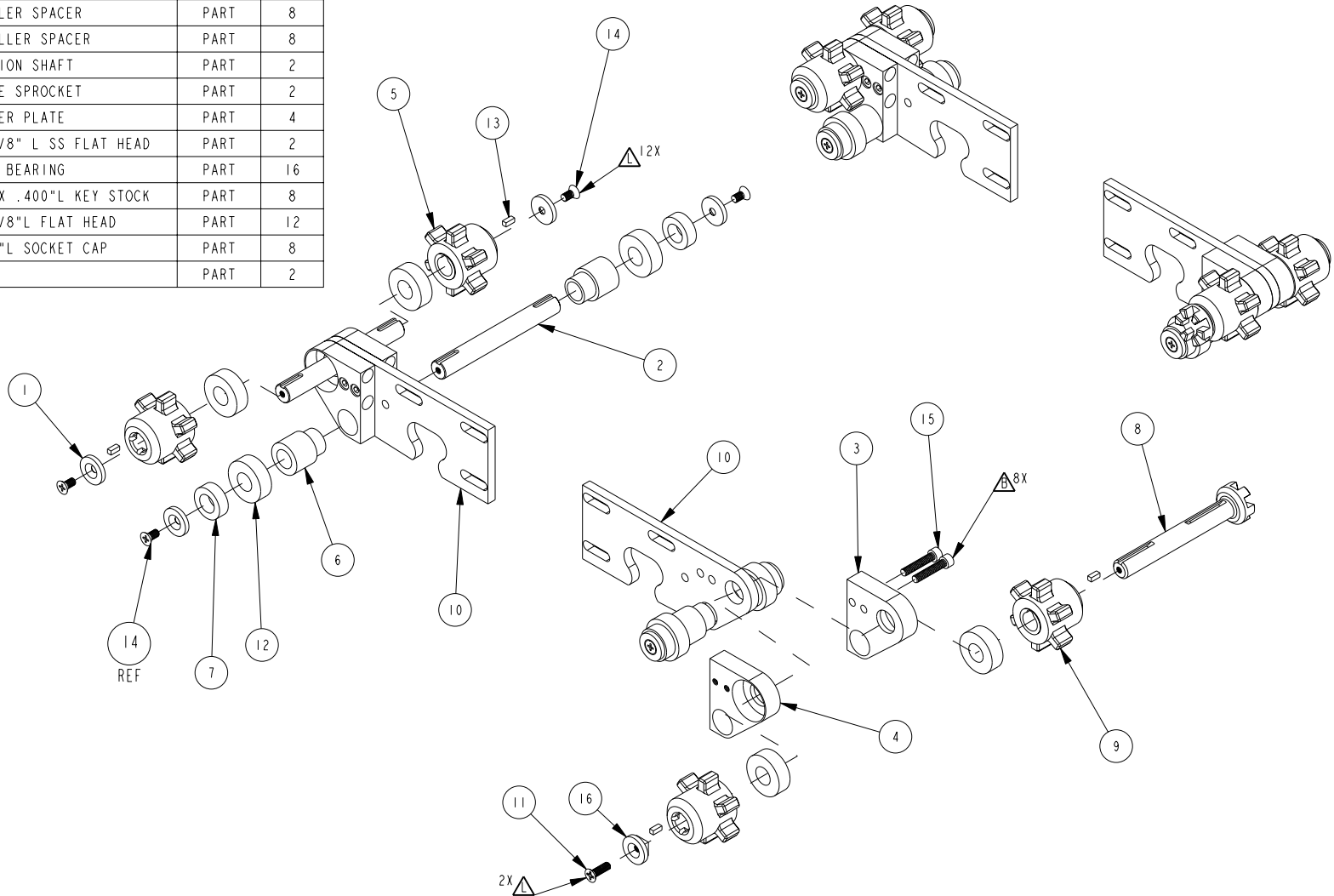

A Touch of Brass
A TOUCH OF BRASS INC

13832 MAGNOLIA AVE.
CHINO, CA 91710-7027
909-464-1000

TIX4 RAIL ASSEMBLY

DWG. NO. 09619

REV E

UNLESS OTHERWISE SPECIFIED, DIMENSIONS ARE IN INCHES.



SCALE 0.250

APPR.

SHEET 3 OF 4

BILL OF MATERIAL (CURRENT LEVEL)

ITEM	PT/ASSY	DESCRIPTION	TYPE	QTY.
1	22422	TUG SHAFT RETAINER	PART	12
2	22646	T1.5 SPROCKET	PART	12
3	22836	T1.5 4" AXLE	PART	6
4	22915	T1.5 TRACK ROLLER	PART	4
5	22916	T1.5 TRACK ROLLER SHAFT	PART	4
6	23338	TIX2 OUTSIDE RAIL PLATE	PART	2
7	23339	TIX2 INSIDE RAIL PLATE	PART	2
8	23341	TIX RAIL LONG TOP PLATE	PART	2
9	92012	RAIL SPACER OD .54" ID .285"	PART	16
10	92325	10-24 X 3/8"L CAP SCREW	PART	4
11	95025	1/2" BALL BEARING	PART	20
12	95026	1/8" SQ. X .400"L KEY STOCK	PART	12
13	95092	10-32 X 3/8"L FLAT HEAD	PART	12
14	95124	1/4"-20 X 1.5" L SOCKET CAP	PART	16
15	95200	1/4"-20 X 1" L SOCKET CAP	PART	12
16	96294	TUG SPROCKET SPACER	PART	8

 BLUE REMOVABLE LOCTITE
 LOCTITE JOINT (GREEN)

NOTES:

1. ALL SCREWS SHOULD BE TIGHTENED AND FUNTION VERIFIED BEFORE COMPLETING WORKORDER
2. GLUE WILL BE APPLIED ON FINAL TUG ASSEMBLY

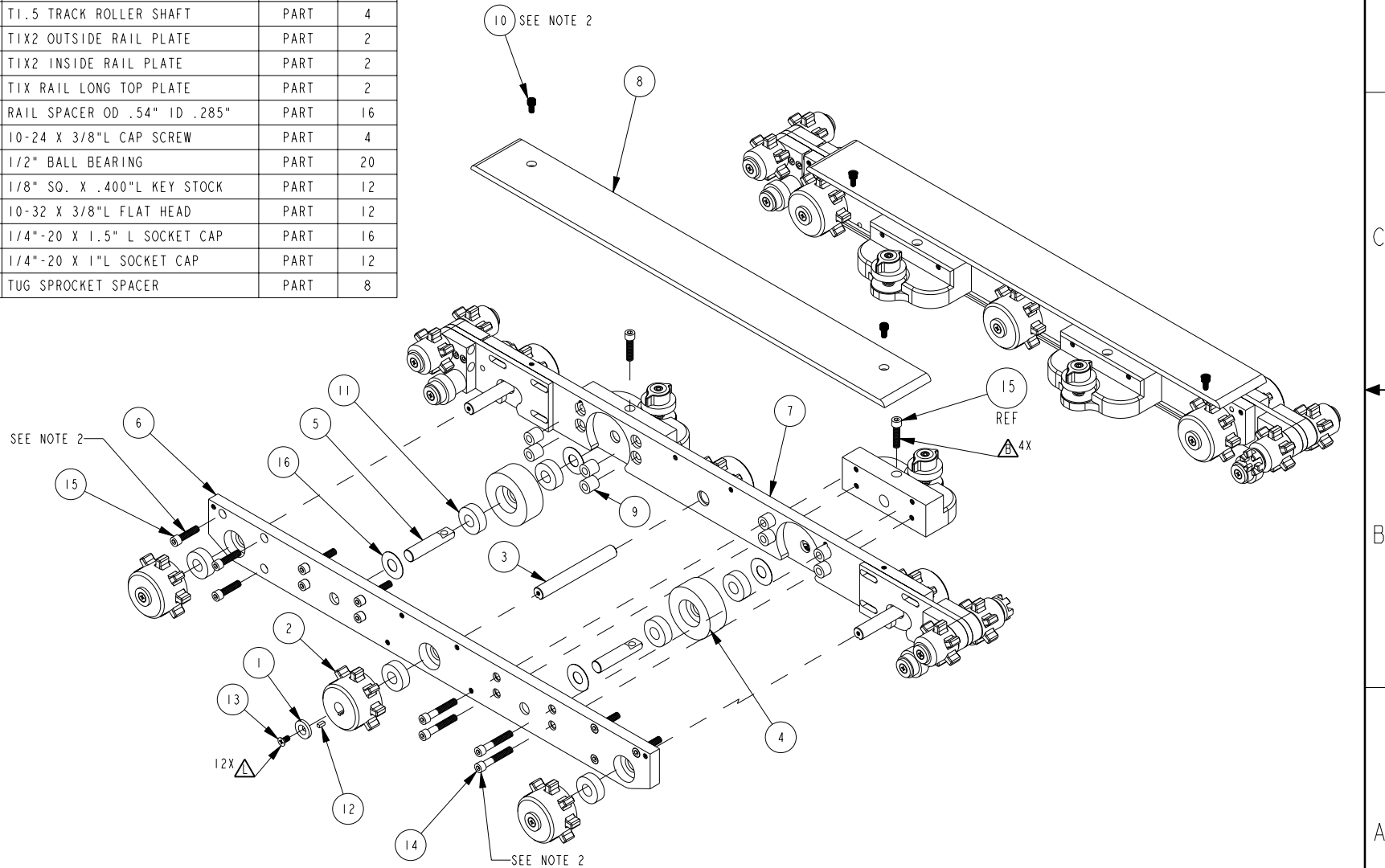

A Touch of Brass
A TOUCH OF BRASS INC

13832 MAGNOLIA AVE.
CHINO, CA 91710-7027
909-464-1000

TIX4 RAIL ASSEMBLY

DWG. NO. **09619**

REV
E

UNLESS OTHERWISE SPECIFIED, DIMENSIONS ARE IN INCHES.

SCALE 0.170

APPR.

SHEET 4 OF 4