

NOTE:

1. THE RAIL ASSEMBLY SHOULD YEILD A LEFT AND RIGHT ASSEMBLY

REFER TO ASSEMBLY VIEW BELOW:

PART 23338 (OUTSIDE PLATE) SHOULD BE ON THE OUTSIDE
 PART 23339 (INSIDE PLATE) SHOULD BE ON THE INSIDE

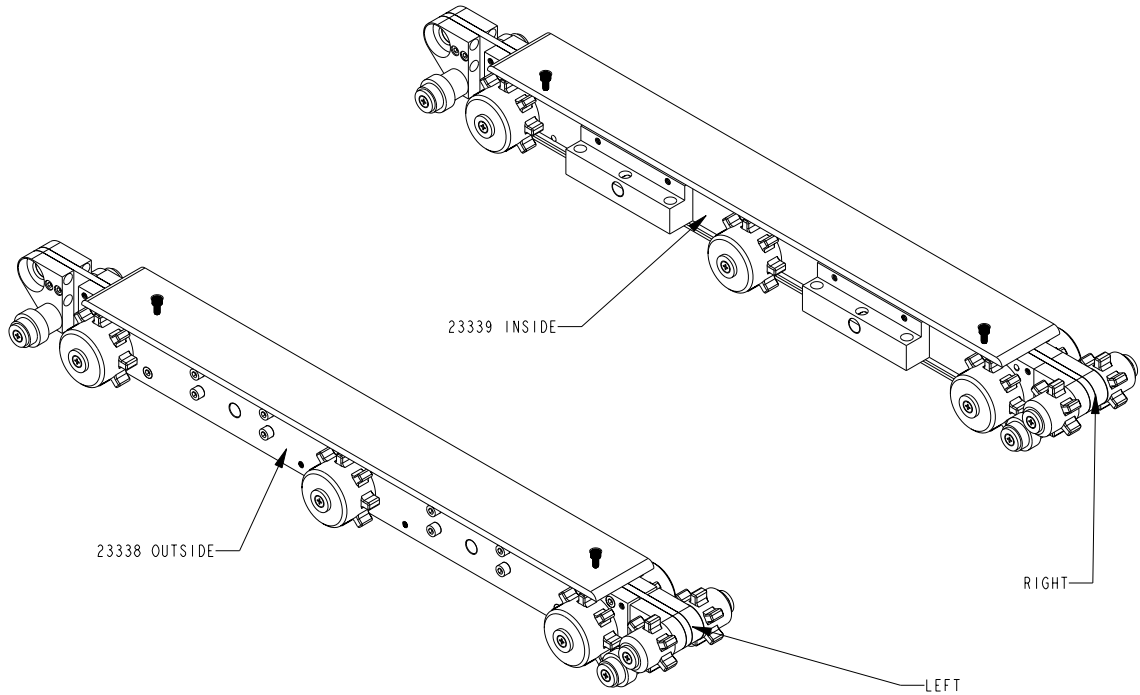

BILL OF MATERIAL (CURRENT LEVEL)

ITEM	PT/ASSY	DESCRIPTION	TYPE	QTY.
1	22422	TUG SHAFT RETAINER	PART	24
2	22646	TI.5 SPROCKET	PART	12
3	22836	TI.5 4" AXLE	PART	12
4	22915	TI.5 TRACK ROLLER	PART	4
5	22916	TI.5 TRACK ROLLER SHAFT	PART	4
6	22981	TIXB RAIL END RIGHT	PART	4
7	22982	TIXB RAIL END LEFT	PART	4
8	22996	DRIVE SPROCKET	PART	4
9	23338	TIX2 OUTSIDE RAIL PLATE	PART	2
10	23339	TIX2 INSIDE RAIL PLATE	PART	2
11	23341	TIX RAIL LONG TOP PLATE	PART	2
12	23364	TIX2 RAIL SUPPORT	PART	4
13	23490	INNER ROLLER SPACER	PART	8
14	23491	OUTTER ROLLER SPACER	PART	8
15	24535	TIX4 SLIDER PLATE	PART	4
16	92012	RAIL SPACER OD .54" ID .285"	PART	16
17	92325	10-24 X 3/8"L CAP SCREW	PART	4
18	95025	1/2" BALL BEARING	PART	32
19	95026	1/8" SQ. X .400"L KEY STOCK	PART	16
20	95092	10-32 X 3/8"L FLAT HEAD	PART	24
21	95124	1/4"-20 X 1.5" L SOCKET CAP	PART	16
22	95200	1/4"-20 X 1" L SOCKET CAP	PART	12
23	95269	10-24 X 1" L SOCKET CAP	PART	8
24	96294	TUG SPROCKET SPACER	PART	8

A Touch of Brass
 A TOUCH OF BRASS INC

13832 MAGNOLIA AVE.
 CHINO, CA 91710-7027
 909-464-1000

TIX2 RAIL ASSEMBLY

DWG. NO. **09562**

REV H

UNLESS OTHERWISE SPECIFIED, DIMENSIONS ARE IN INCHES.

SCALE 0.170

APPR.

SHEET 1 OF 2

▲ LOCTITE JOINT (GREEN): MFR. LOCTITE MODEL #: 680 OR EQUIVALANT
 ▲ BLUE REMOVABLE LOCTITE: MFR. LOCTITE MODEL #: 242 OR EQUIVALANT

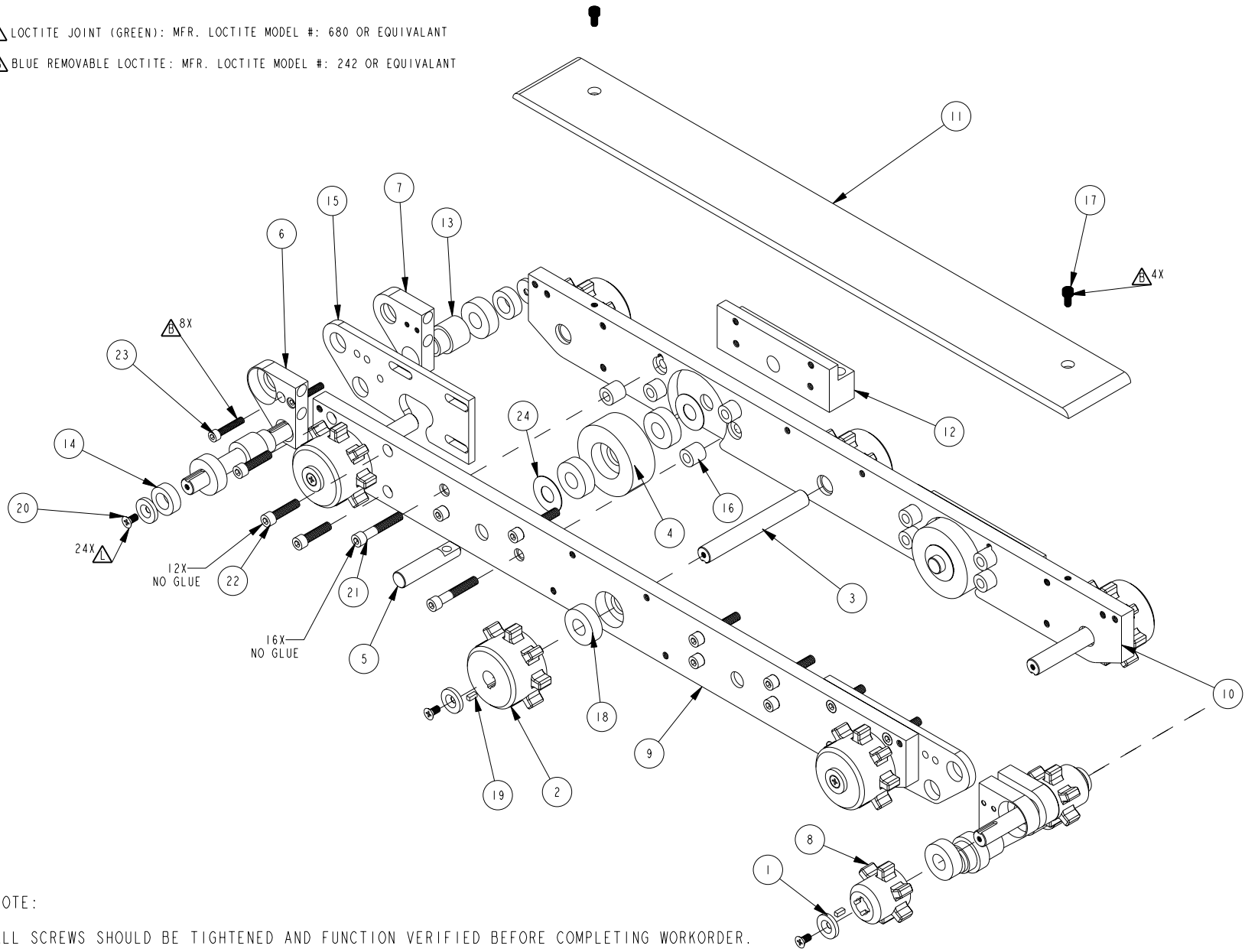

NOTE:
 ALL SCREWS SHOULD BE TIGHTENED AND FUNCTION VERIFIED BEFORE COMPLETING WORKORDER.

A Touch of Brass
 A TOUCH OF BRASS INC

13832 MAGNOLIA AVE.
 CHINO, CA 91710-7027
 909-464-1000

TIX2 RAIL ASSEMBLY

DWG. NO. 09562

REV H

SCALE 0.240

APPR.

SHEET 2 OF 2

UNLESS OTHERWISE
 SPECIFIED, DIMENSIONS
 ARE IN INCHES.