



A Southwire Company

# LED UNDER CABINET LIGHTS

## 5 CCT SELECTABLE



FOR KITCHENS, HOME OFFICES,  
AND WORKSHOP TASK LIGHTING

[TOPAZ-USA.COM](http://TOPAZ-USA.COM)

**CCT Selectable: 2700K, 3000K, 3500K, 4000K, 5000K. Choose from a range of warm to cool color temperatures.**



**Adjust your lighting preference with a simple switch.**



**A large wiring compartment, snap-in hinged door and multiple knockouts make installation easy and effortless.**



**Connect up to six fixtures for uniform illumination with an end-to-end connector or use the optional linking cables to create custom lengths.**

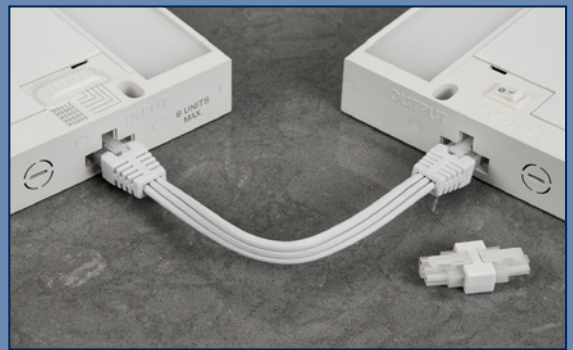

# LED UNDER CABINET LIGHTS

5 CCT SELECTABLE

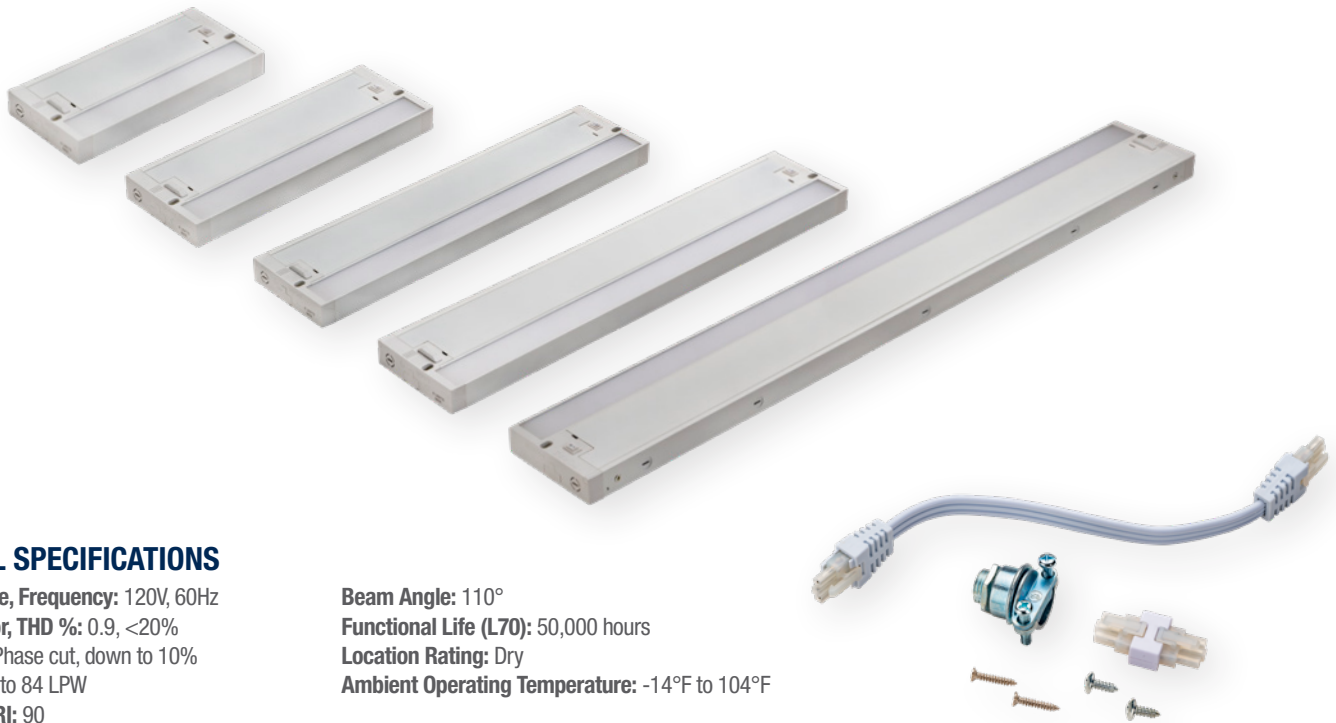

## GENERAL SPECIFICATIONS

**Input Voltage, Frequency:** 120V, 60Hz  
**Power Factor, THD %:** 0.9, <20%  
**Dimmable:** Phase cut, down to 10%  
**Efficacy:** Up to 84 LPW  
**Minimum CRI:** 90

**Beam Angle:** 110°  
**Functional Life (L70):** 50,000 hours  
**Location Rating:** Dry  
**Ambient Operating Temperature:** -14°F to 104°F



## ITEM SPECIFICATIONS / ORDER INFO

Catalog Number	Order Code	UPC	CCT	Lumens	Wattage	Input Current
UCW9-CTS-D-WH	73694	751338044029	2700K   3000K   3500K   4000K   5000K	355   360   370   375   385	5W	45mA
UCW12-CTS-D-WH	73695	751338044036	2700K   3000K   3500K   4000K   5000K	435   445   455   465   475	6W	55mA
UCW18-CTS-D-WH	73696	751338044043	2700K   3000K   3500K   4000K   5000K	695   705   725   735   750	9W	80mA
UCW21-CTS-D-WH	73697	751338044074	2700K   3000K   3500K   4000K   5000K	850   860   880   895   910	11W	90mA
UCW33-CTS-D-WH	73698	751338044081	2700K   3000K   3500K   4000K   5000K	1,270   1,285   1,300   1,330   1,350	16W	135mA

## NOMENCLATURE

UCW=Under Cabinet Wide - 9=9" - CTS=CCT Selectable 2700K | 3000K | 3500K | 4000K | 5000K - D=Dimmable - WH=White  
 12=12"  
 18=18"  
 21=21"  
 33=33"

## ACCESSORIES (SOLD SEPARATELY)

Catalog Number	Order Code	UPC	Description
UC/LC12-36	71068	751338038097	12" 18AWG Link Cable
UC/LC24-36	71074	751338038103	24" 18AWG Link Cable
UC/PC39-36	71075	751338038110	39" Power Cord



# LED UNDER CABINET LIGHTS

5 CCT SELECTABLE

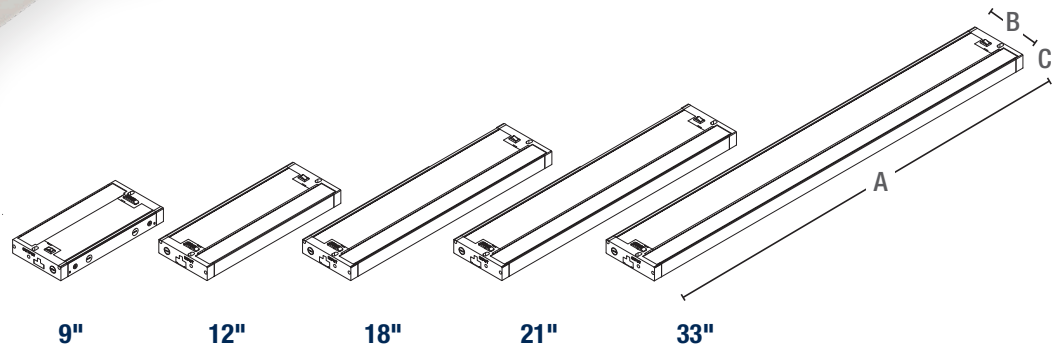

## DIMENSIONS/WEIGHTS

Catalog Number	(A)	(B)	(C)	Weight
UCW9-CTS-D-WH	9"	4.33"	1.09"	0.8 Lbs.
UCW12-CTS-D-WH	12"	4.33"	1.09"	1.0 Lbs.
UCW18-CTS-D-WH	18"	4.33"	1.09"	1.3 Lbs.
UCW21-CTS-D-WH	21"	4.33"	1.09"	1.5 Lbs.
UCW33-CTS-D-WH	33"	4.33"	1.09"	2.4 Lbs.

## NOTES

**Dimming** - This product is designed to be compatible with most leading-edge type incandescent and LED style dimmers. (Dimming range 100% down to 5%). Product performance may vary depending on dimmer manufacturer and circuit loading. Visit [www.topaz-usa.com/led-dimmer-compatibility](http://www.topaz-usa.com/led-dimmer-compatibility) for up-to-date dimmer compatibility information.

This device complies with Part 15 of the FCC Rules. Operation is subject to the following two conditions: (1) this device may not cause harmful interference, and (2) this device must accept any interference received, including interference that may cause undesired operation.

**FIVE (5) YEAR LIMITED WARRANTY:** SOUTHWIRE COMPANY, LLC: For details visit <https://southwire.com/resources/warranties>

Specifications subject to change without prior notice.