



<b>Project:</b>	<b>Type:</b>
<b>Prepared By:</b>	<b>Date:</b>

## Technical Specifications

### Listings

**UL Listed:**

Suitable for wet locations

### Electrical

**Power Consumption:**

1W

**Surge Protection:**

Withstands up to 6000 volts

**Wall Switch Manual Override:**

Two flip logic prevents activation by momentary power outages. Override resets to auto at dawn. No extra wiring needed.

**RF Immunity:**

Circuits fully shielded for maximum radio frequency immunity

**Voltage:**

120 Volts AC 60 Hertz

**Switching Capacity:**

1000 watts incandescent @ 120 volts, 8 amps

### Sensor Specifications

**Time Adjustment:**

5 seconds to 12 minutes

**Wide Sensitivity Control:**

Adjustable from 100% to 30%

**Advanced Detection Logic:**

Minimizes false triggers

**Photoelectric Control:**

Deactivates lights during daylight. Fully adjustable for 24 hour operation or custom applications.

**Detection:**

Angle of view = 110°  
 Recommended Mounting Height = 10'-0"  
 Maximum Recommended Look-Out Zone = 50'-0"

### Construction

**Temperature Compensation:**

Sensitivity adjusts automatically for consistent detection in hot and cold ambient temperatures

**Horizontal Lock, No-tool Joints:**

Keeps sensing pattern level for fast, error-free installation

### Floodlights:

Precision die cast aluminum. 1/2" NPS threaded arm with serrated locking swivel fits all standard mounting boxes and covers.

### LED Characteristics

**LED Detection Indicator:**

Shows when sensor is detecting in daytime and glows red at night for "on-guard" deterrence

**Color Matched Lens:**

Dark lens with bronze units, white lens with white units

### Other

**Warranty:**

10 year sensor warranty

**Buy American Act Compliance:**

RAB values USA manufacturing! Upon request, RAB may be able to manufacture this product to be compliant with the Buy American Act (BAA). Please contact customer service to request a quote for the product to be made BAA compliant.

## Dimensions

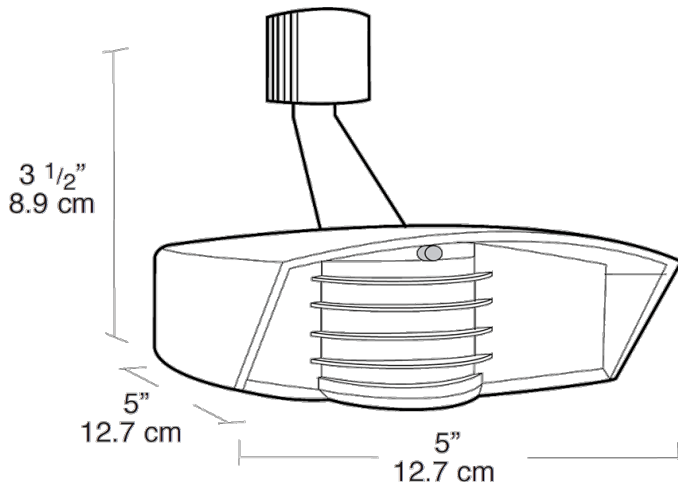

## Features

- Temperature compensation
- Radio frequency immunity
- 6000 volt surge protection
- LED detection & "on guard" indicator
- Color matched vandal resistant lens and grill
- Protected manual override with auto reset
- Can be wired in parallel