

DESCRIPTION

2-4 Lamps | T8HO or T12HO | 12'-32' Combined Lamp Length | Series Wiring

STARTING METHOD: Programmed Rapid Start

INPUT VOLTAGE: 120-277VAC ±10%

LAMP CONNECTION: Series

INPUT FREQUENCY: 60Hz

PRODUCT FEATURES

- Sound Rated: A
- Minimum Starting Temperature: -20°F, -29°C
- Maximum Case Temperature: 176°F, 80°C
- Meets FCC Part 18 (Class A) Non-Consumer Limits
- UL, cUL 935 Listed, Class P, Type 2 Outdoor, Type HL

ELECTRICAL SPECIFICATIONS

Lamps		Lamp Footage		Input Voltage	Max Input Watts	Nominal Line Amps	Power Factor	Harmonic Total	Crest Factor
Type	Number of Lamps	Min.	Max.						
T12HO	4,3,2	12	32	120	282	2.35	> 0.90	< 10	< 1.7
		12	32	277	275	0.99	> 0.90	< 10	< 1.7
T8HO	4,3,2	12	24	120	256	2.13	> 0.90	< 10	< 1.7
		12	24	277	252	0.90	> 0.90	< 10	< 1.7

LAMP FOOTAGE

Lamp Type	Minimum	Maximum
T12HO	12'	32'
T8HO	12'	24'

MECHANICAL SPECIFICATIONS

CASE DIMENSIONS

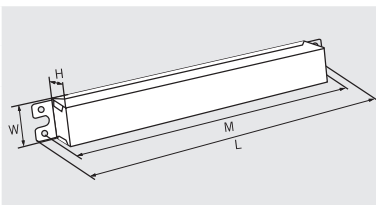

LENGTH	14.3"
WIDTH	3.15"
HEIGHT	1.18"
MOUNTING	13.75"
CASE STYLE	L29

STANDARD LEAD LENGTHS*

WHITE	25"
BLACK	25"
BLUE	72"
RED	72"
YELLOW	72"
BROWN	72"
BLUE/WHITE	72"

Lead wires are 18 AWG 105°C/600V, solid copper.

CASE MATERIAL: Metal

*Consult Keystone for special lead length requirements.

FOR INSTALLATION PURPOSES

Ballast consists of two lamp circuits - Circuit A and Circuit B. Circuit A consists of lamps 1, 2 and Circuit B consists of lamps 3, 4.

- Each lamp circuit can drive 1 or 2 T12HO lamps in any combination from 6'-16'.
- Each lamp circuit can drive 1 or 2 T8HO lamps in any combination from 6'-12'.

Each lamp circuit should be balanced with equal lamp load (footage).

WIRING DIAGRAMS

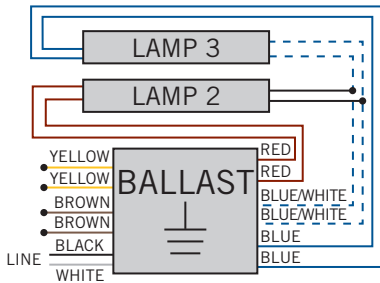

Two Lamp Application, Cap Off
Unused Leads Individually,
Insulate to 600V

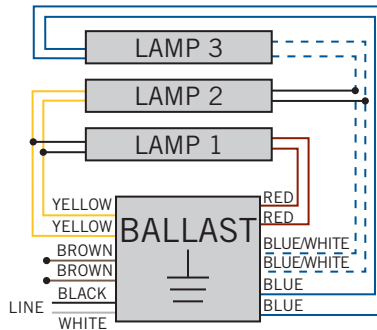

Three Lamp Application, Cap Off
Unused Leads Individually,
Insulate to 600V

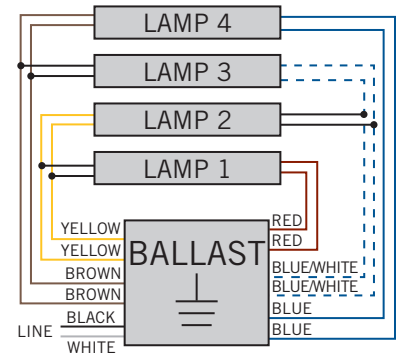

Four Lamp Application

ORDERING INFORMATION

ORDER CODE	PACKAGING STYLE	PACK QTY.	ITEM STATUS
KTSE-E-1232-24-UV-S-IP	Individually Packaged	1	Quick Ship

CATALOG NUMBER BREAKDOWN

KTSE-E-1232-24-UV-S-IP



*Minimum and maximum total lamp length based on T12HO lamps.