

# assembly instructions



## MODULAR BATTERY BOX FOR TESLA BATTERY MODULES

### **CAUTION \*\*\* PLEASE READ!**

*Use of this product is intended for those with experience working with high voltage. Such work must always be done with care and caution. **An error in judgement could lead to extreme injury from electrical shock, severe burns or even death.** Please be aware that the ampREVOLT Modular Battery Box is wholly constructed out of 6061 billet aluminum, and is thus an **excellent conductor of electricity**. It is incumbent upon the installer to wear all necessary high voltage electrical safety gear whilst installing battery modules, and **electrically insulate all connections** as needed. Please carefully read and understand all precautions referred to throughout this document.*

*Thank you for investing in our battery containment system for 4.5, 5.2 and 5.3kWh Tesla Battery Modules. Our unique design focuses on maximum flexibility for the end user, as well as personal safety and battery protection and longevity.*

#### *Recommended tools/supplies:*

- *3mm hex wrench (included)*
- *Philips head PH2 screwdriver*
- *Blue thread-lock for all screw fasteners*
- *Inch-pound torque wrench*
- *Angle grinder for modules with aluminum flanges or tin snips for those with plastic flanges*

## 1. Carefully unpack all battery box parts

All 1/8" aluminum plates have been powder-coated with the most rugged finish available, however they are not scratch-proof, so care should always be taken when handling. Be sure to use only mild soap and water when cleaning finish, however automotive polish (i.e. Mother's Mag) can be used via a microfiber cloth to remove fingerprints or other blemishing.

## 2. Assemble box sides - Right side

Note that the battery box sides are assembled from an assortment of six different panel types. Inspect the following drawings carefully as some panels do have similarities. Use M5 x .8 x 12 fasteners for this step, leaving them a little loose.

A.

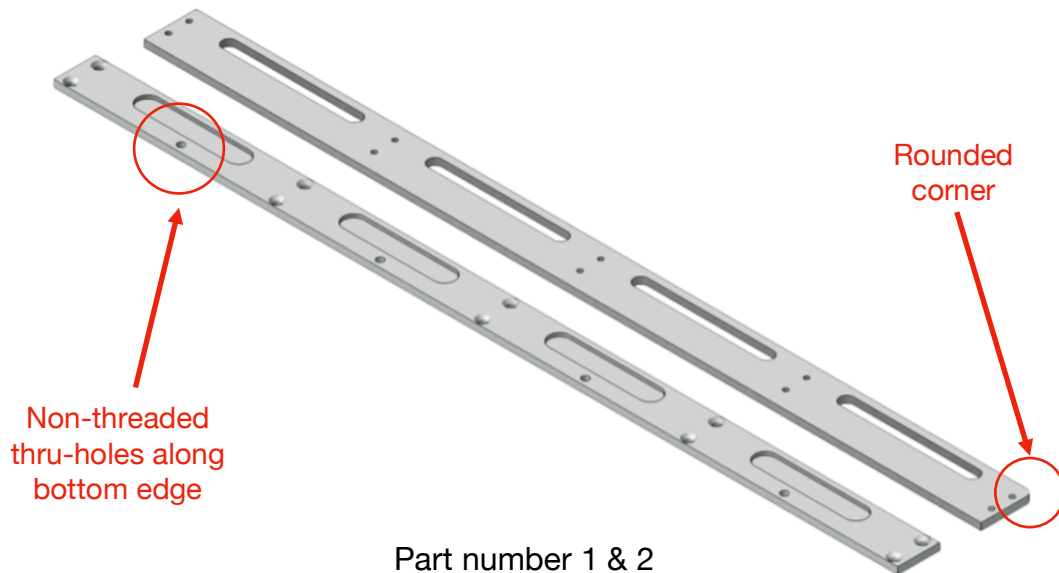

**B.**

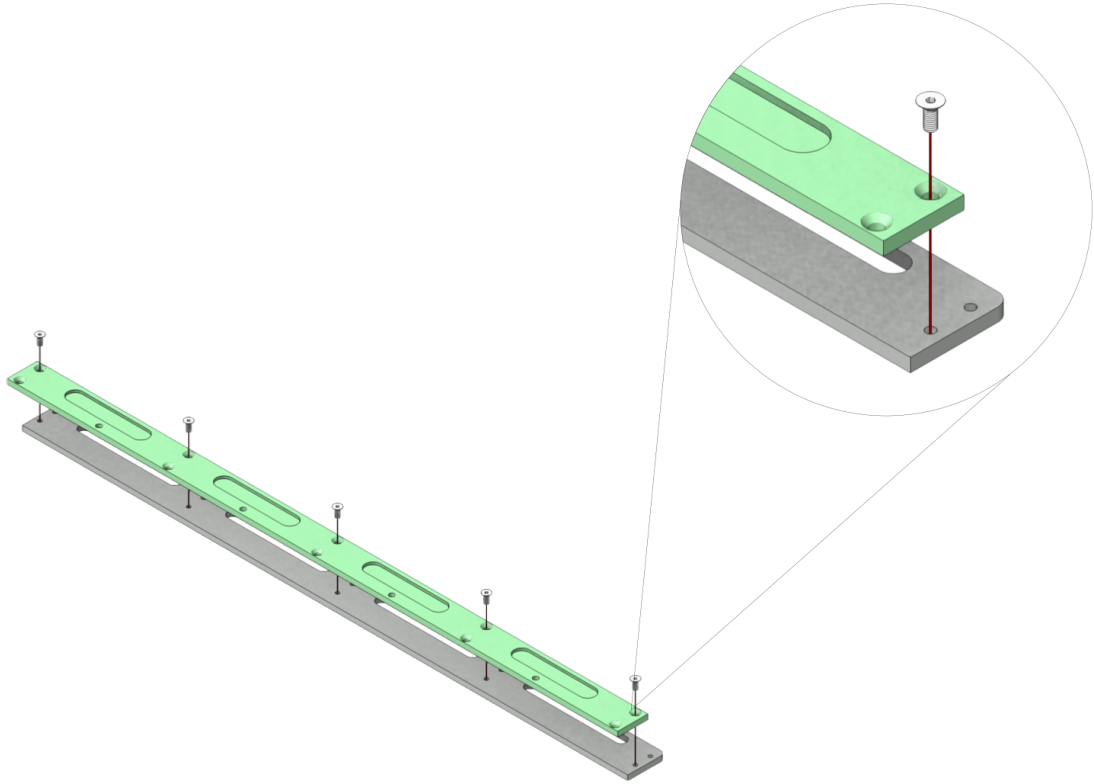

**C.**

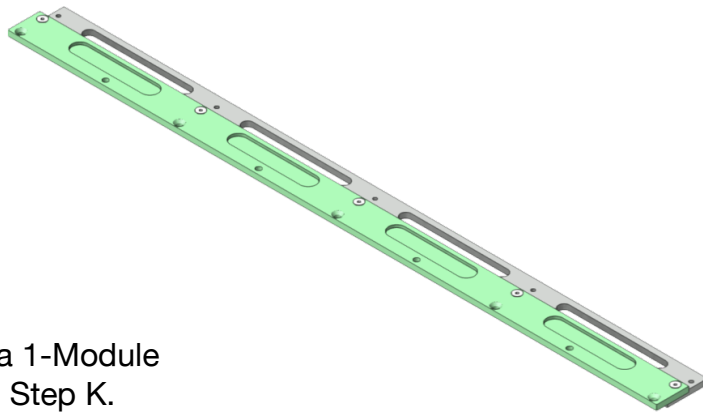

Note: If building a 1-Module Box, skip now to Step K.

D.

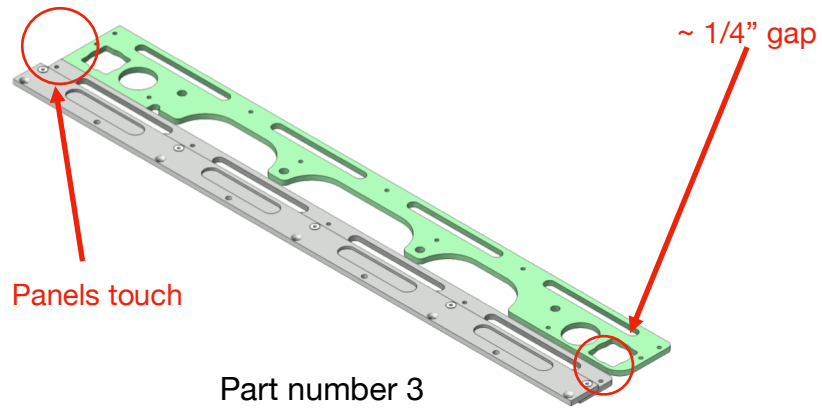

E.

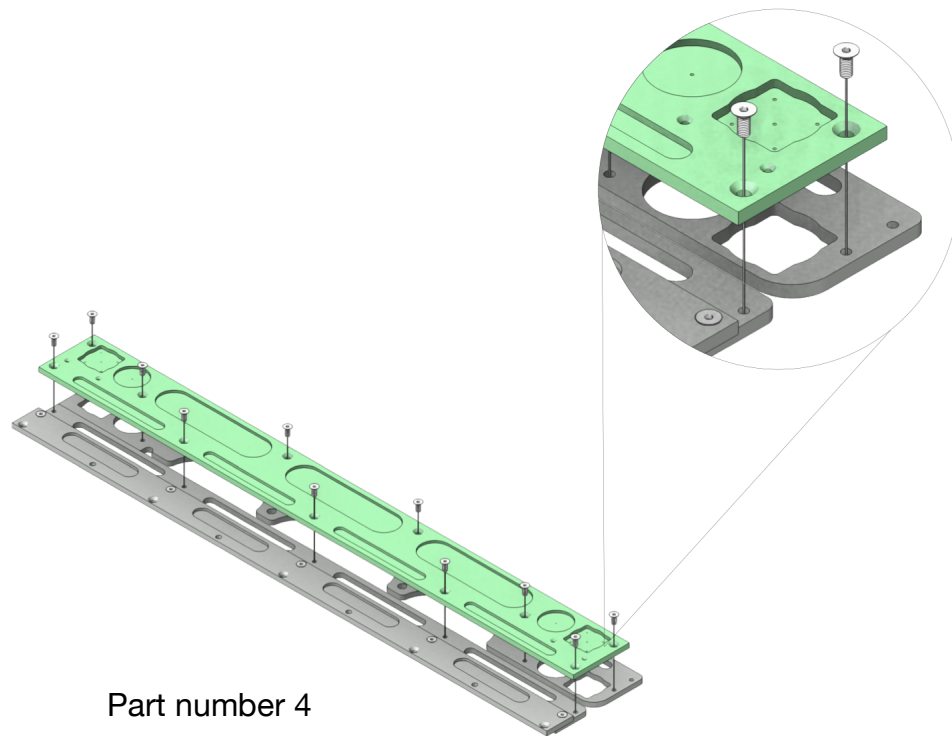

**F.**

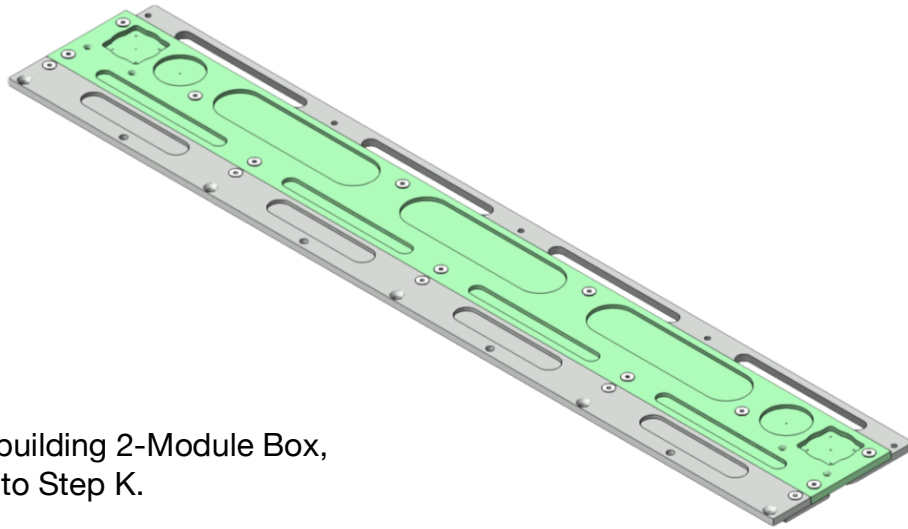

NOTE: If building 2-Module Box,  
skip now to Step K.

**G.**

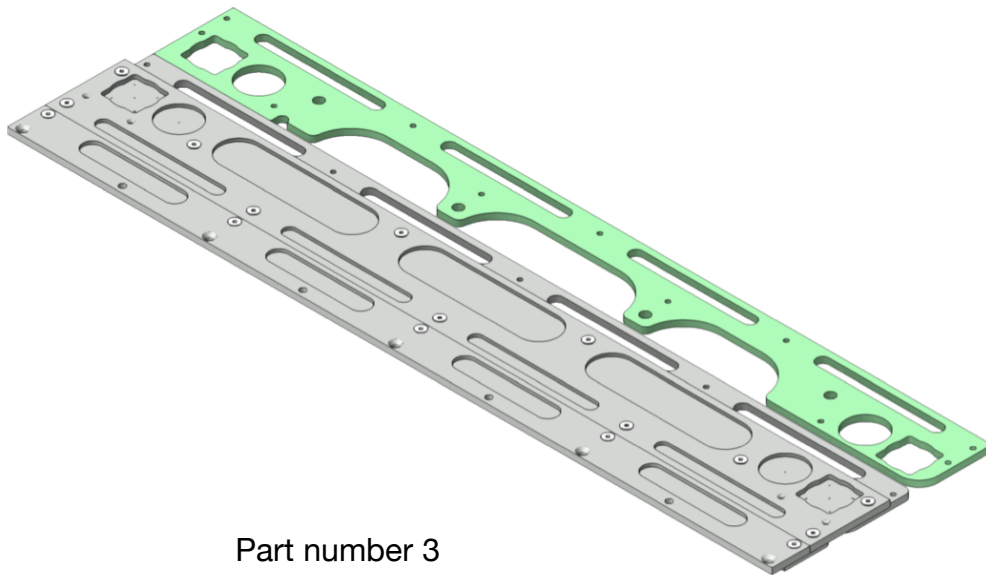

Part number 3

H.

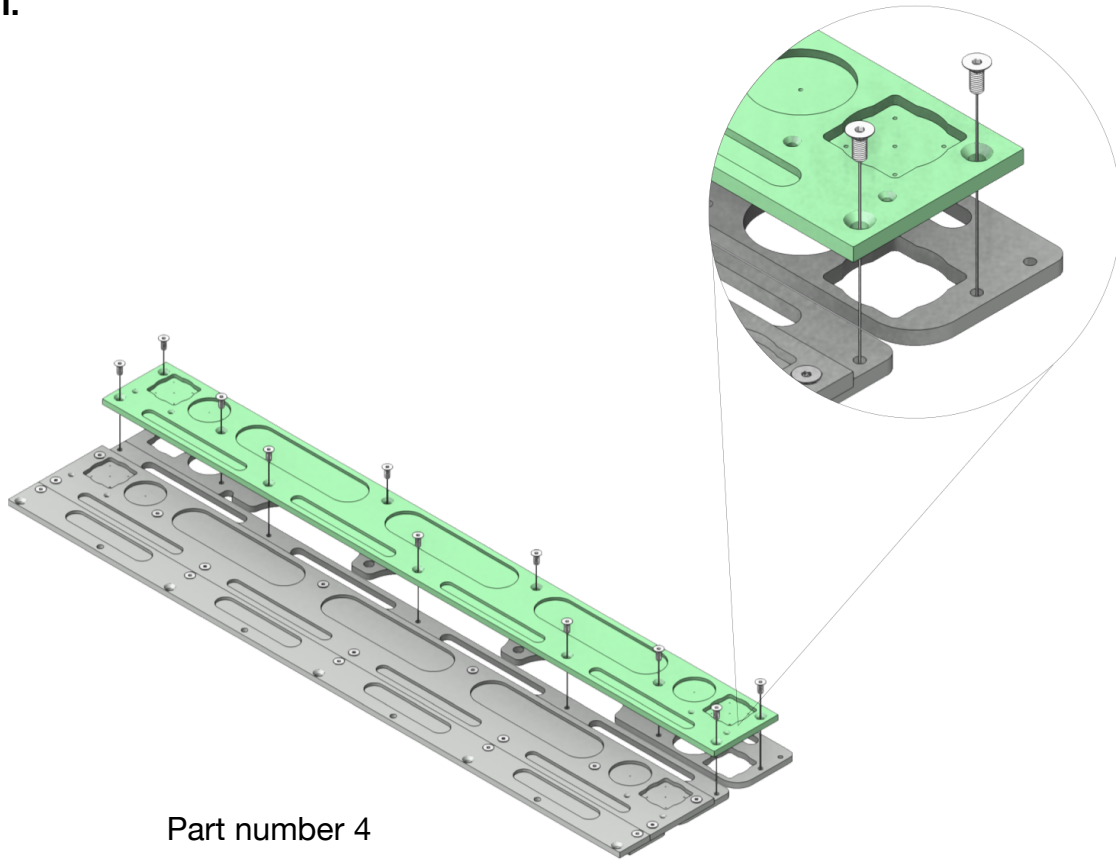

I.

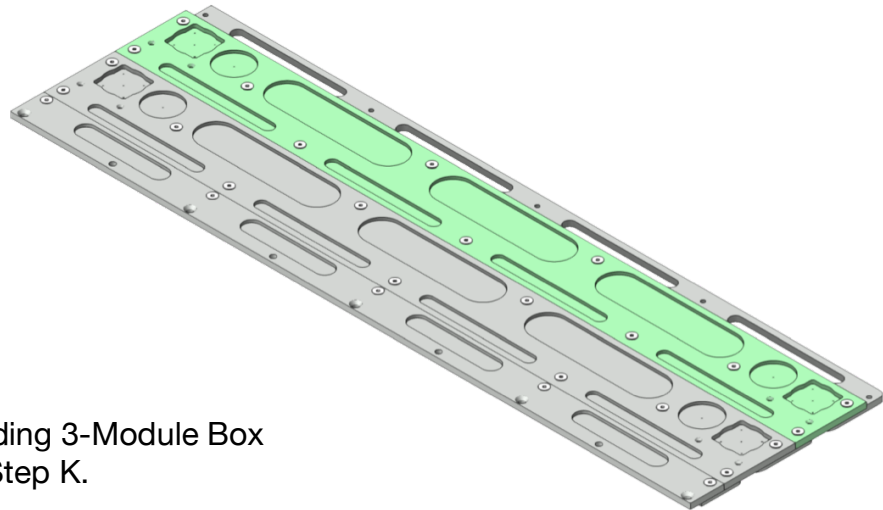

NOTE: If building 3-Module Box  
skip now to Step K.

J. Repeat steps G, H, & I as needed. Number of modules box can accommodate is designated by the number of wider panels + 1. Thus a four-module box requires three of these wider panels.

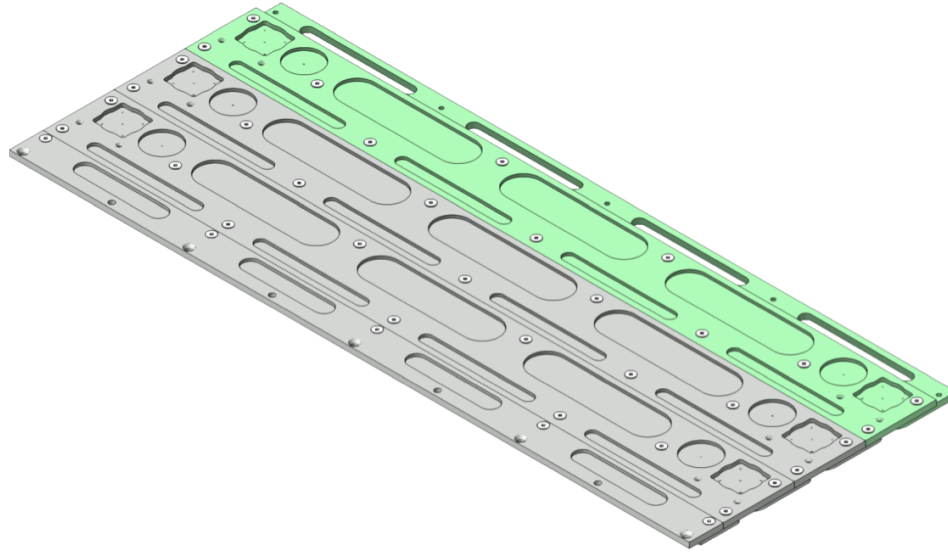

K. Finishing a side assembly requires two final smaller panels.

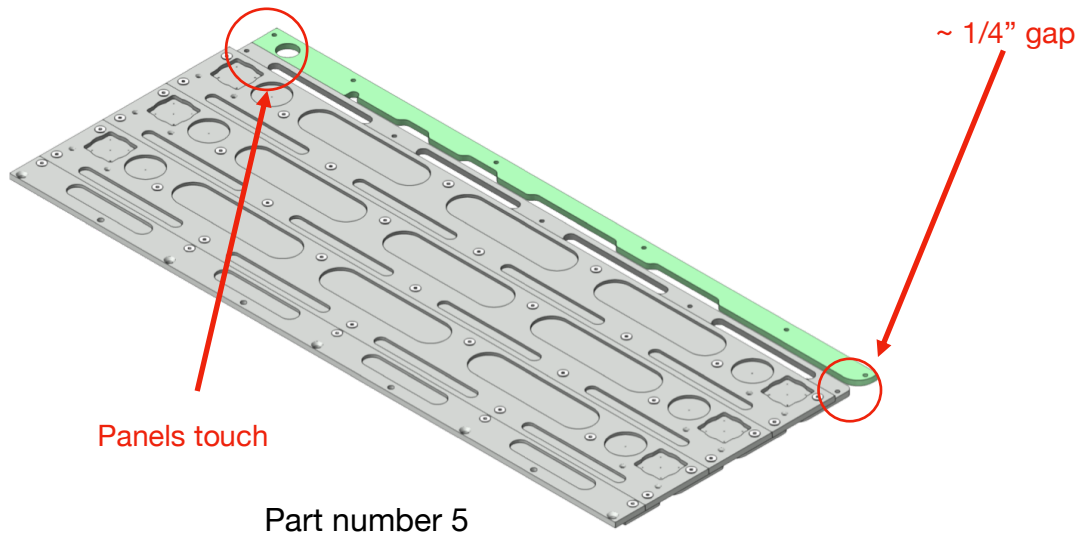

L.

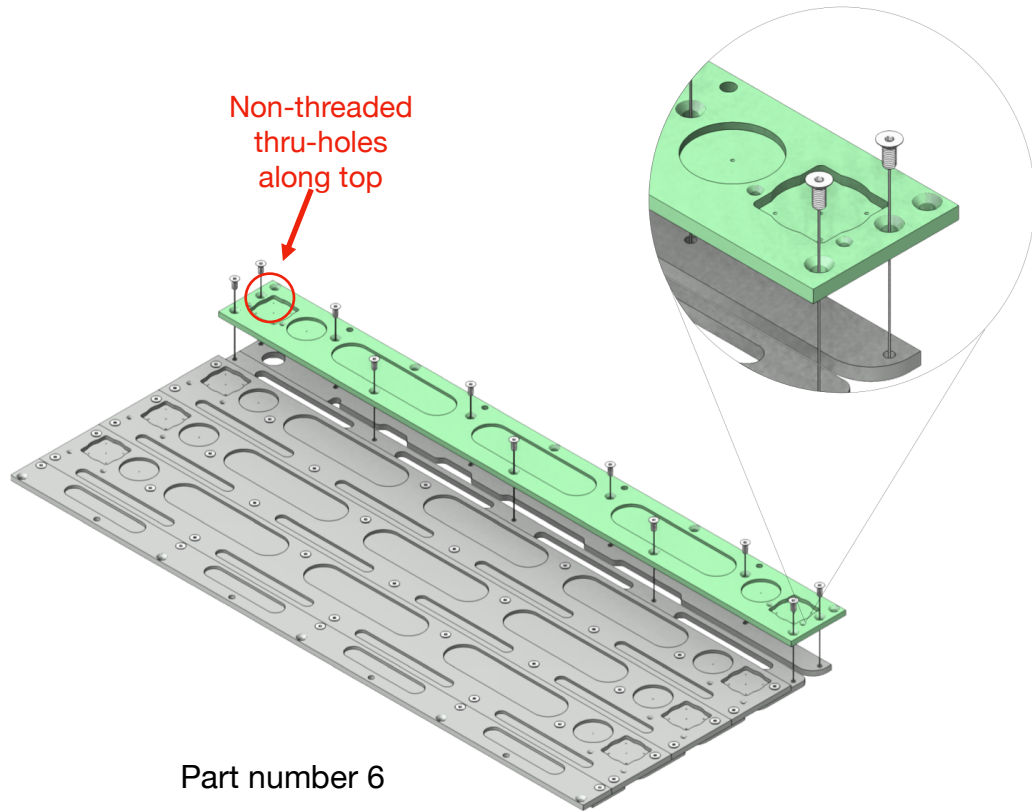

M.

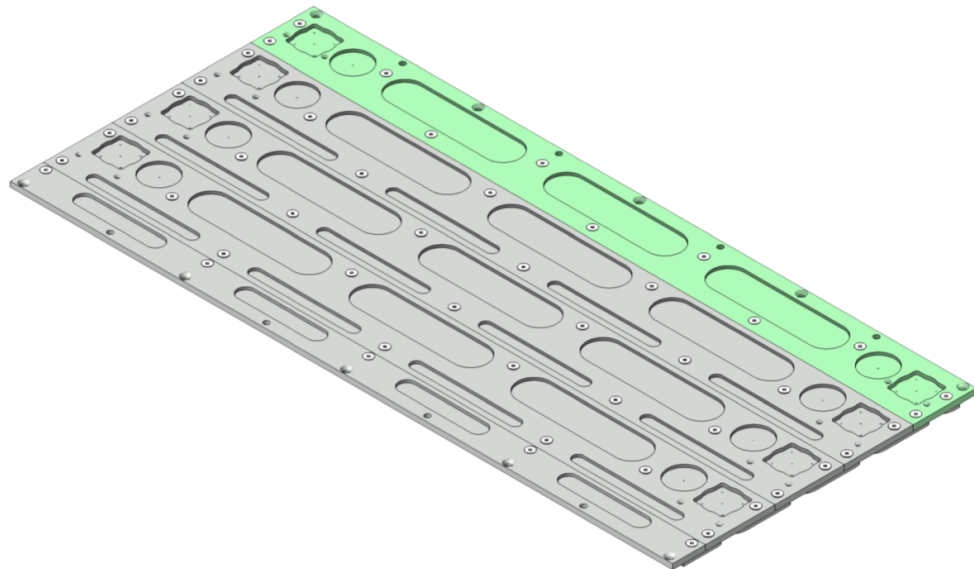



### 3. Assemble box sides - Left side

Use step two again to create mirror image of previous assembly.

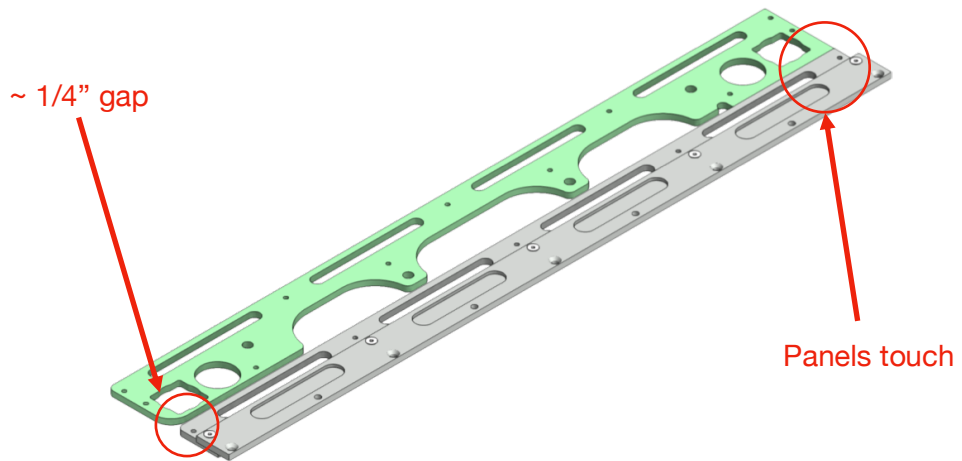

### 4. Assemble box bottom panel

A. Locate ladder frame with fuse plate and lay with plate facing downward.

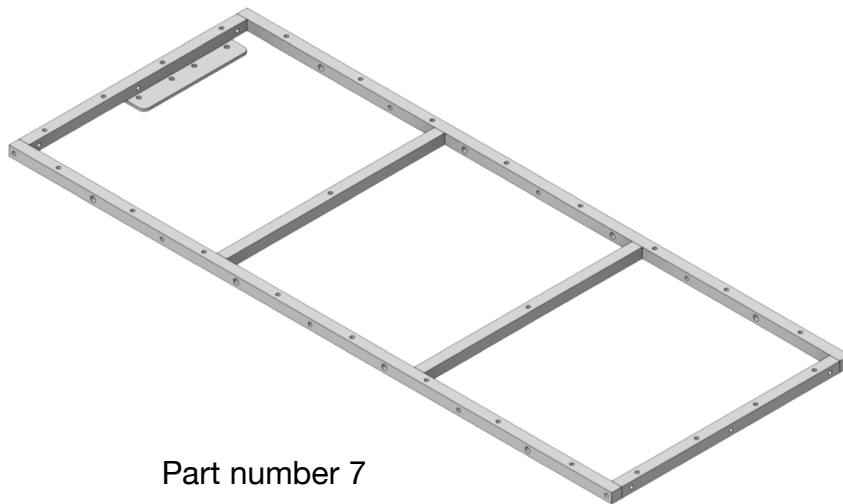

- B.** Locate bottom plate (no logo) and fasten to ladder frame. Use M5 x .8 x 16 fasteners for this step. Tighten all screws to 38 inch-lbs.

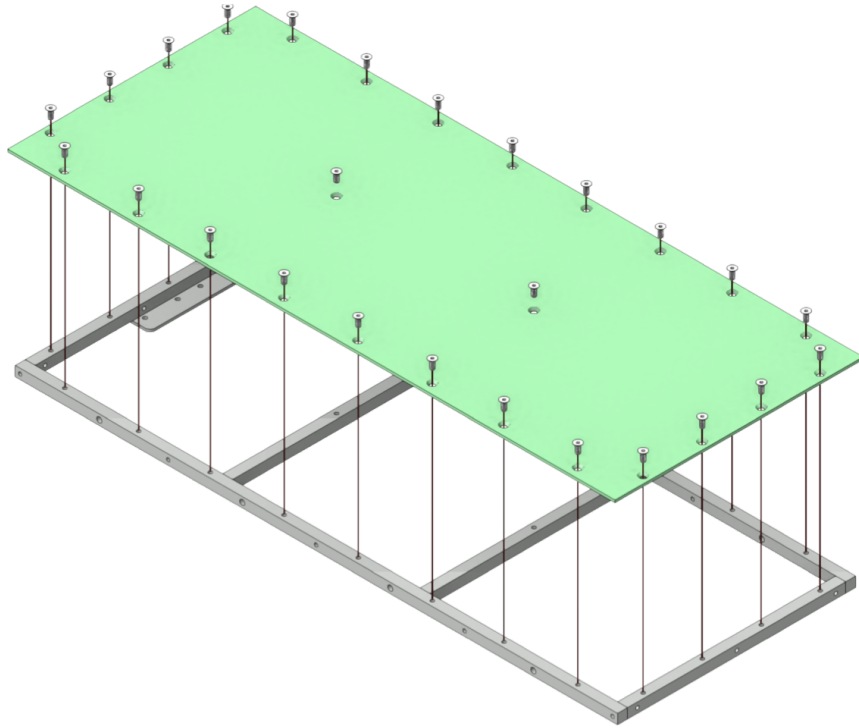

- C.**

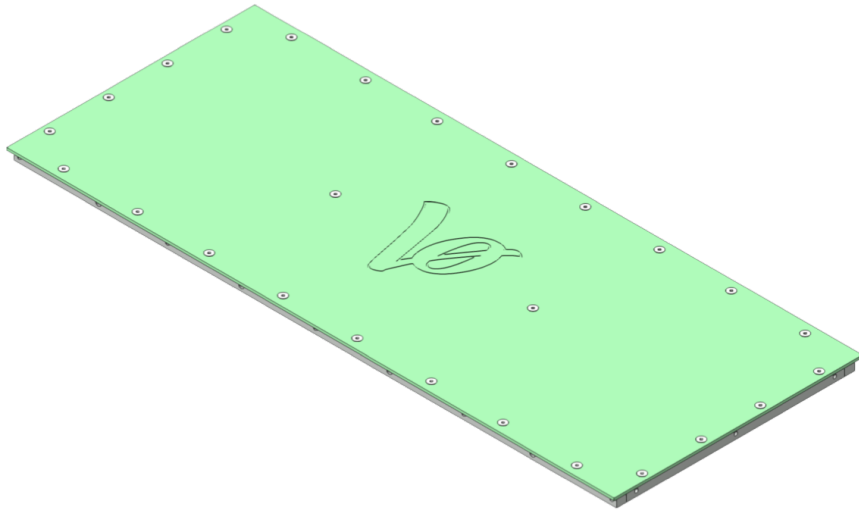

# 5. Join bottom and side assemblies

A. Use M5 x .8 x 16 fasteners for this step.



B.

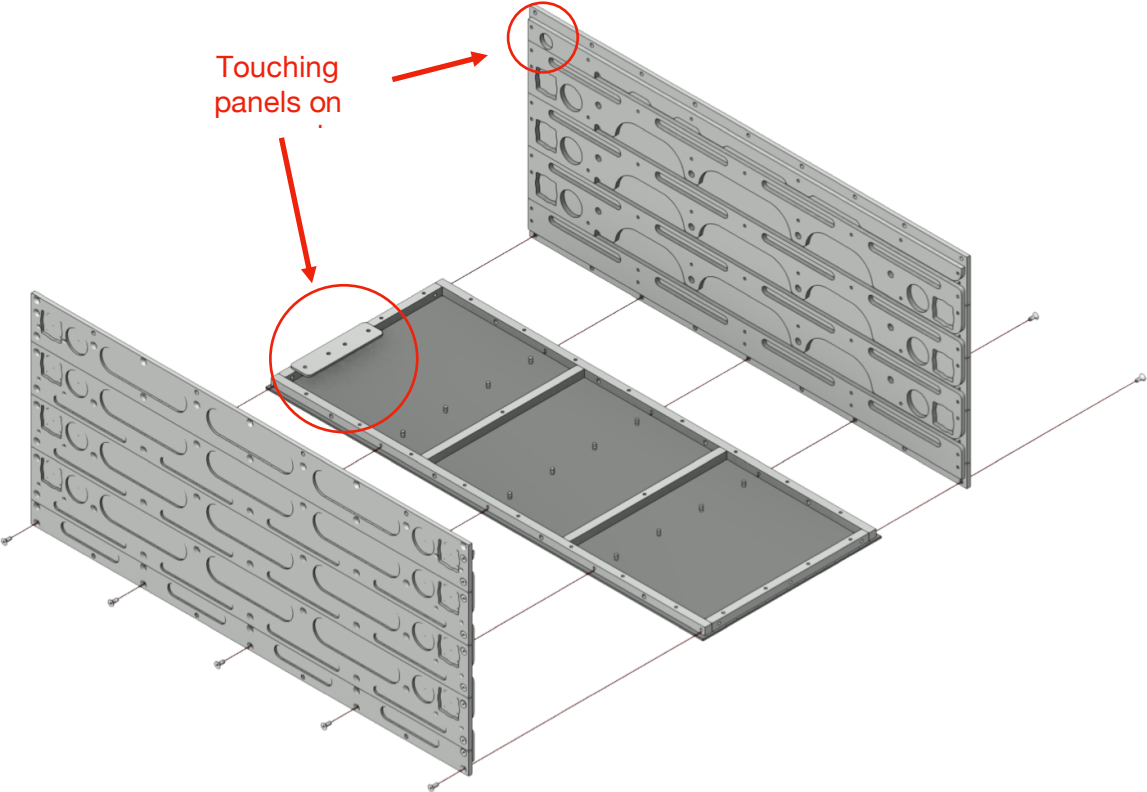

C.

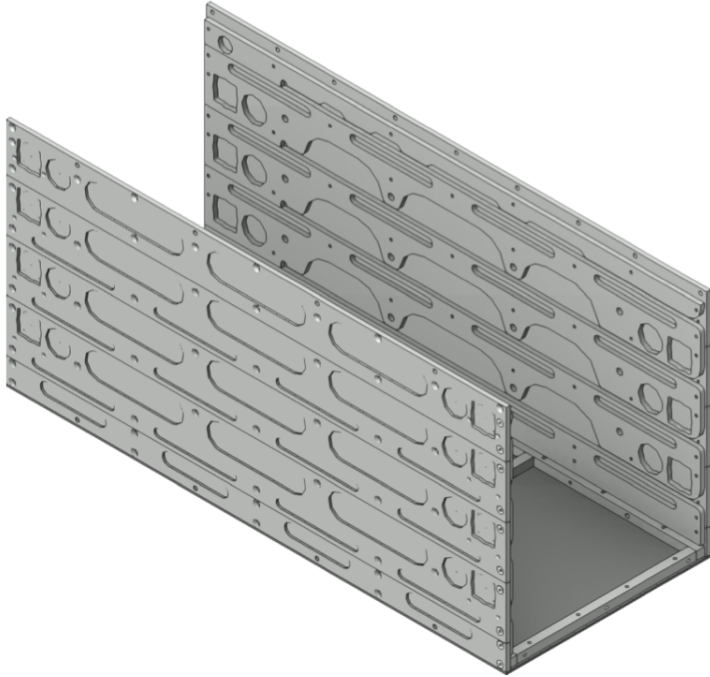

## 6. Attach top ladder frame

Use M5 x .8 x 16 fasteners for this step.

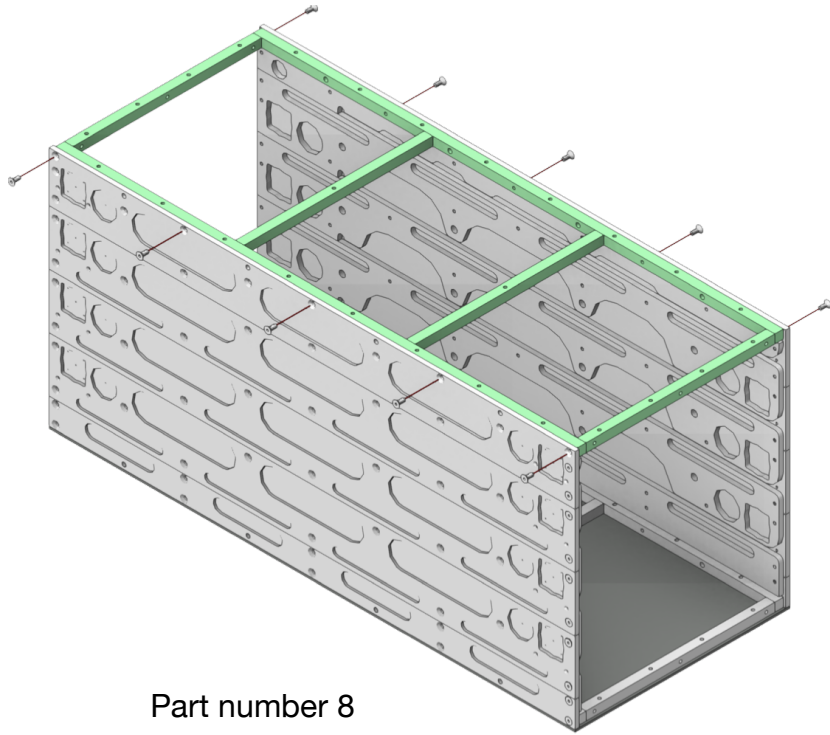

Part number 8

**ampREVOLT.com**  
Zero Emission Electric Drive

**7. Insert module stoppers. Tighten all screws in side assemblies to 38 inch-pounds.**

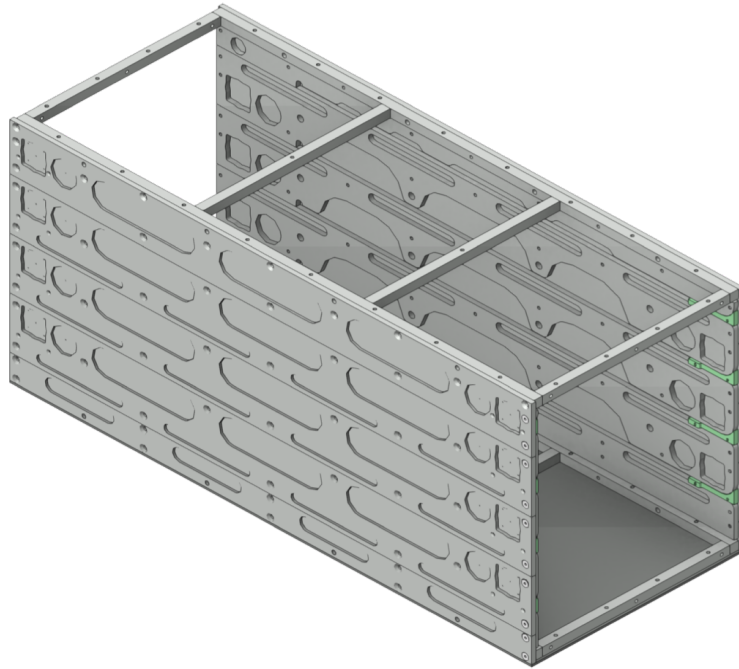

## 8. Remove module flange protrusions (2 per module)

Each S module has two spots where the mounting flange protrudes that should be removed. If your flanges are plastic they can be easily removed with a pair of tin-snips. If aluminum, an angle grinder can be used if done super carefully.

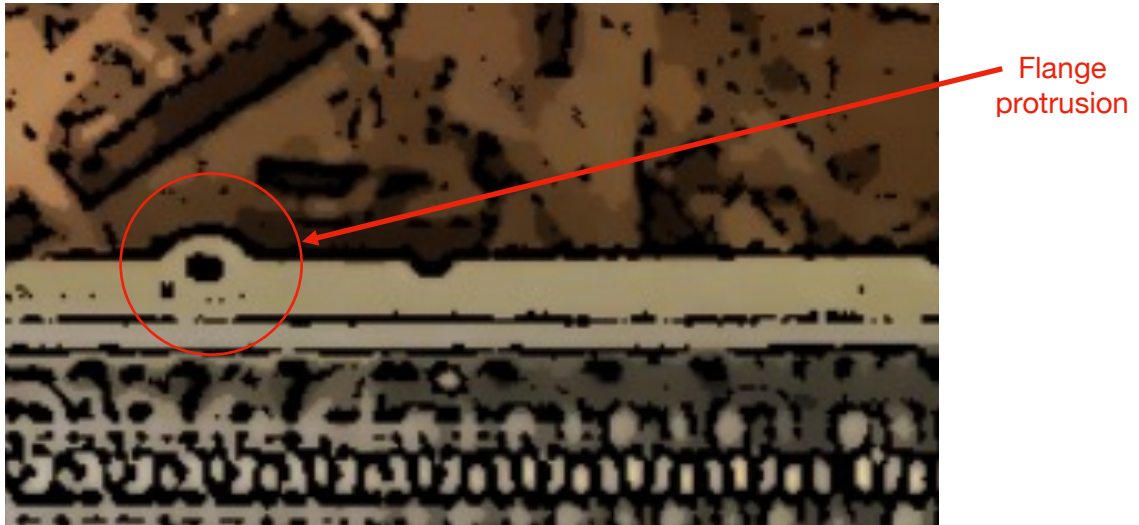

## 9. Slide on flange end-caps and covers

Slide on the included flange grey end-caps and white nylon covers on each side of each module. NOTE: the end-caps fit snug around the flange end closest to the high voltage terminals.

A.

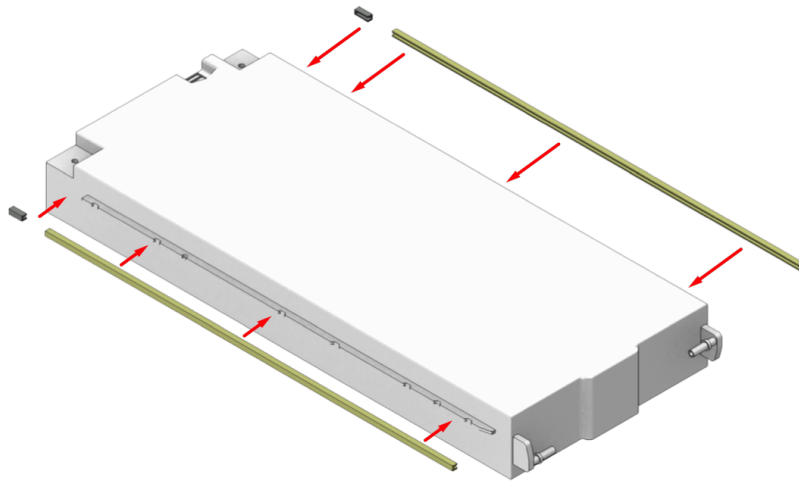

**ampREVOLT.com**  
Zero Emission Electric Drive

**B.**

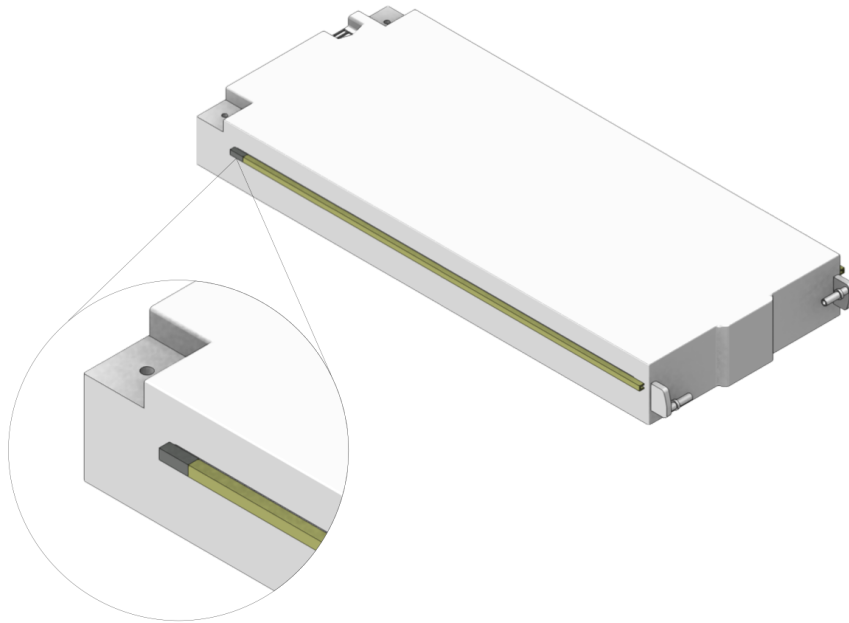

**10. Slide in modules, starting at the bottom (recommended).**

**A.**

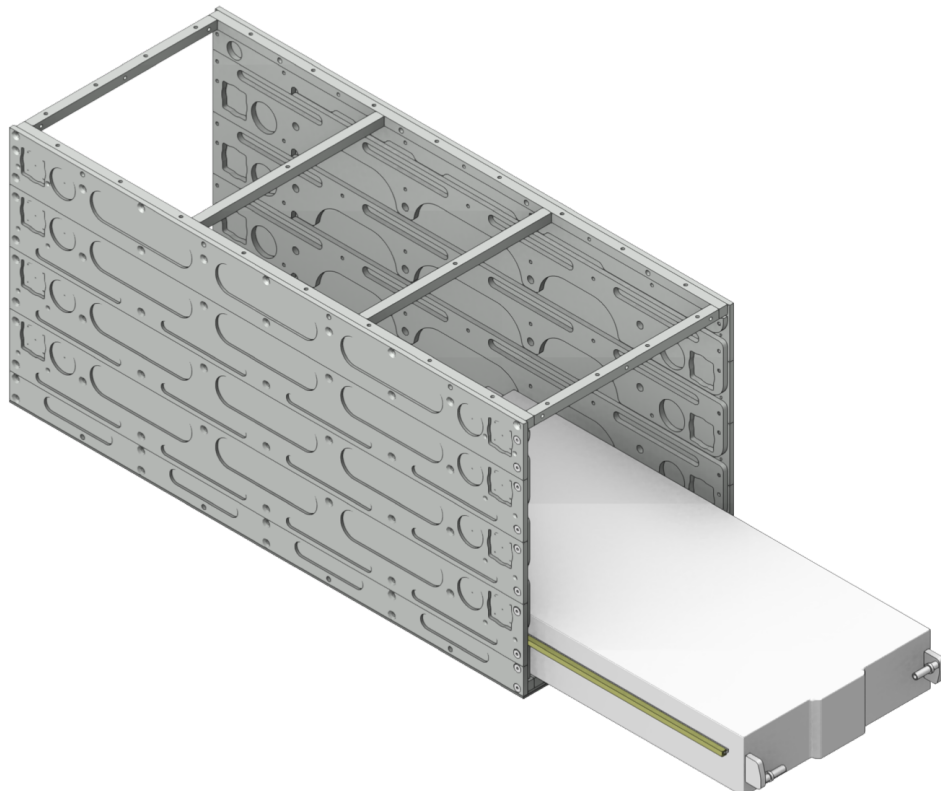

11. Insert module stops and fasten with the included side screws (one 1/2" screw and one 5/8" screw per stopper).

A.

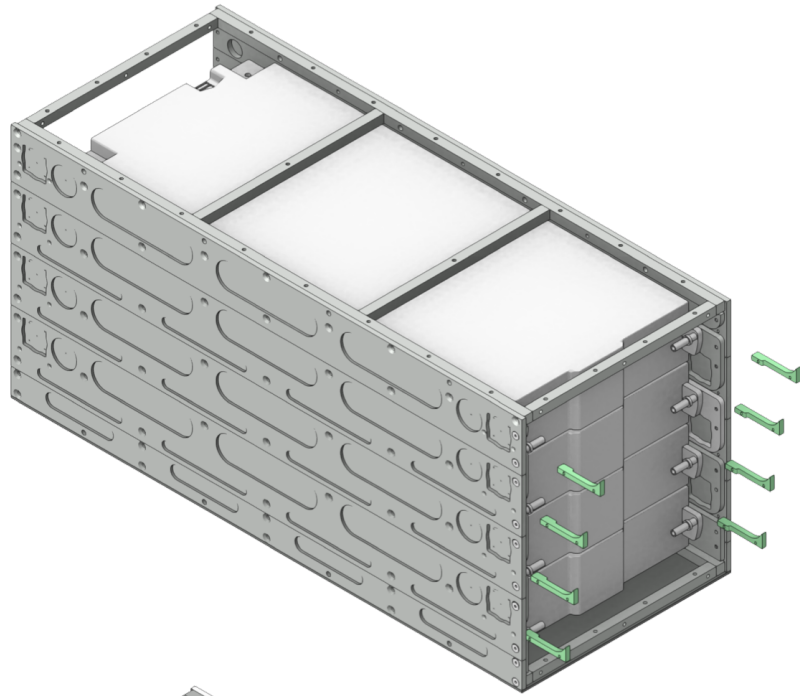

B.

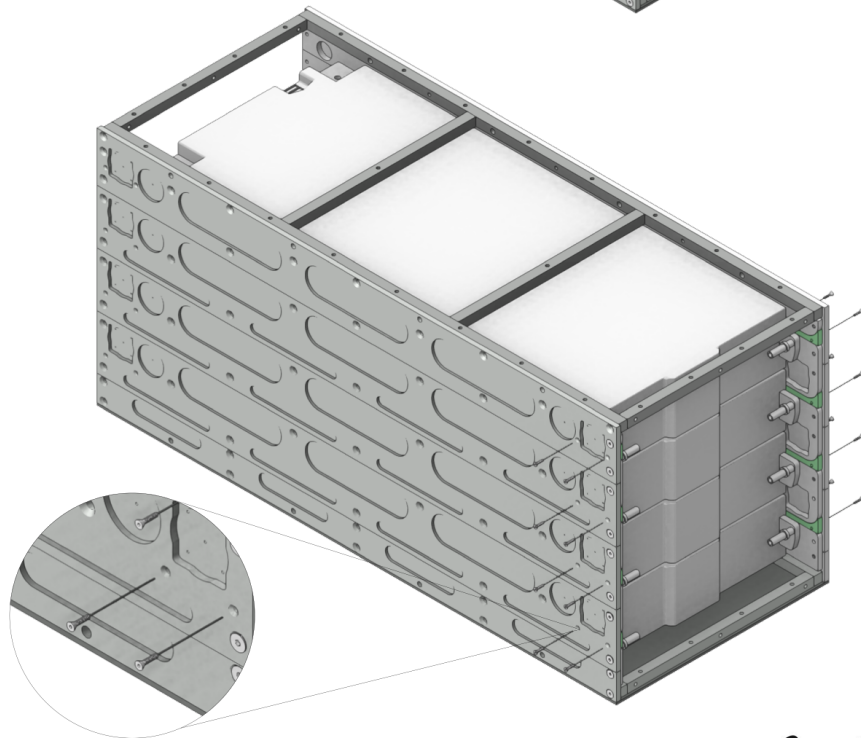



## 12. Attach top, front and back panels

- A.** Use M5 x .8 x 16 fasteners for this step.

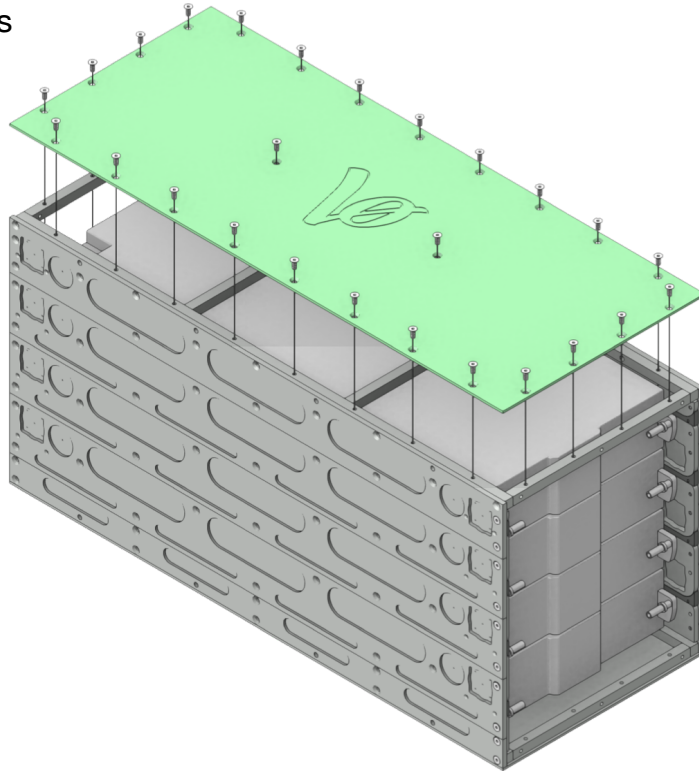

### **B. Note: For 6-module version and larger**

For 6-module boxes and larger, you may prefer to install the included H-Brackets for added stability. **A.** Remove four screws from the side plate assemblies, as pictured. **B.** Partially thread four of the M5 x .8 x 30 screws. **C.** Position the H-bracket. **D.** Screw in the fasteners the rest of the way. **E.** Attach included lock washers and nuts.

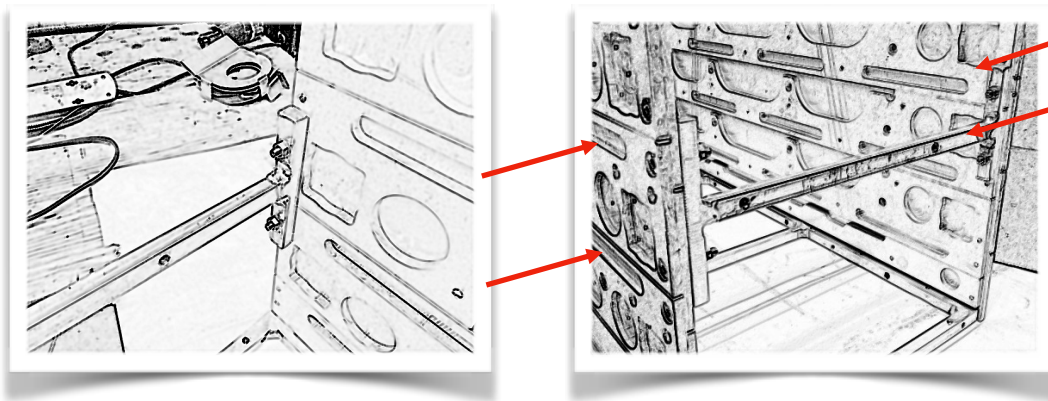

Part number 9

C.

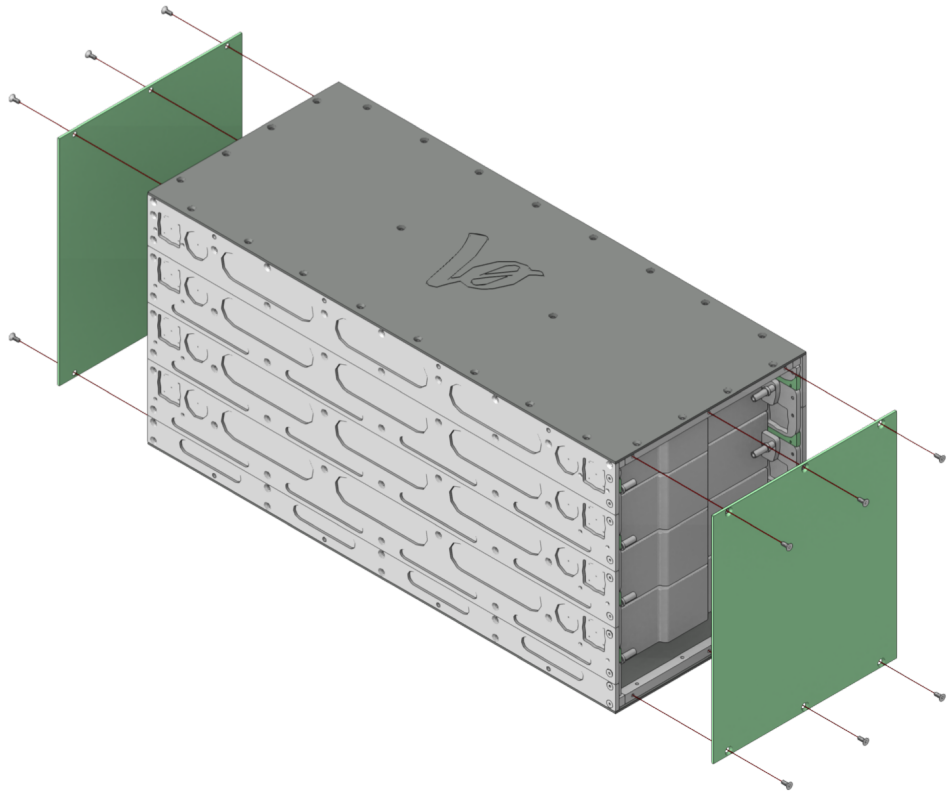

D.

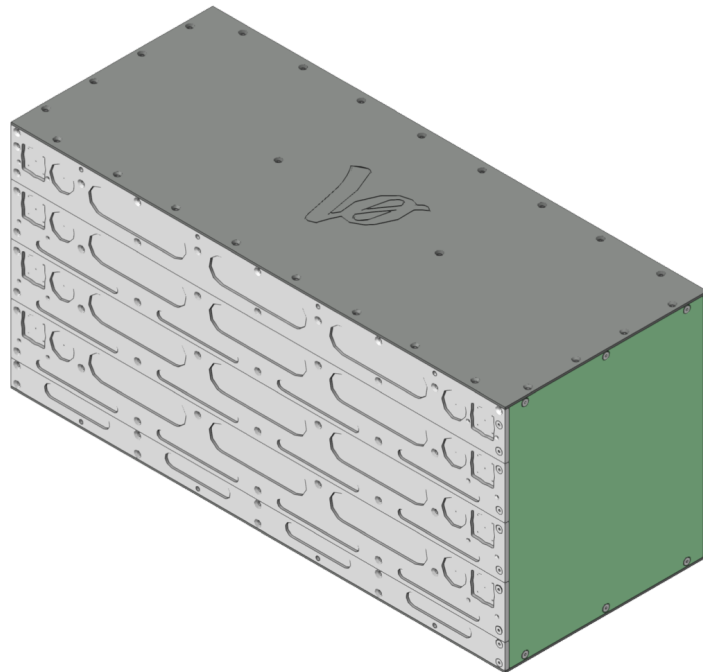

# APPENDIX: Battery Box Parts

## Battery Box Part List

#1	Top outer
#2	Top inner
#3	Side outer
#4	Side inner
#5	Bottom outer
#6	Bottom inner
#7	Top ladder frame
#8	Bottom ladder frame
#9	H-bracket



