



Technical Specification

Model: HK-LF-96-60

HK-LF-108-60

HK-LF-115-58

Name: 6.6KW On-board Charger

Hangzhou Tiecheng Information Technology Co., Ltd

Version	Update	Edit	Audit	Approval	Date
V1.0	Draft	Tianxiang Pan	Lizhen Tang	Hongbin Zhang	2018.5.27

Content

1 Overview	3
1.1 Subject	3
1.2 Main Features	4
2 Charger Technical Specification.....	4
2.1 Environmental Specification	4
2.2 Charger regulatory requirements and reference standards.....	4
3 Charger Safety Regulations Specification	6
4 Charger Electrical Performance	6
4.1 Input.....	6
4.2 Output.....	6
4.3 Low Voltage Output	7
4.4 Control Interface	7
4.5 Other	8
5 Charger Protection Functions	8
6 Interface.....	9
6.1 Low Voltage Connector and Pins Definition.....	9
6.2 High Voltage Connectors and Pins Definition.....	10
6.2.1 AC Input	10
6.2.2 OBC Output.....	10
7.Size and Appearance.....	11
7.1.Size and weight	11
7.2 Appearance.....	11

1 Overview

1.1 Subject

HK-LF full-sealed on-board OBC and DC/DC integrated is a product specially designed for new energy vehicle by Hangzhou Tiecheng Information Technology Co., Ltd according to China standard QC/T895-2011 Conductive On-board Charger for Electric Vehicle and GB/T24347-2009 Electrical Vehicle DC/DC Converter, which function is as the battery charger of new energy vehicle This product not only have the advantages of high efficiency, small size, high stability, long-lifetime but also have the performance of high protection level, high reliability, more protection functions, it is a ideal power supply solution for electrical vehicle. Thermal sensor is built-in the charger, has the function of over-temperature and can

auto-recovery when temperature decreased. With the process of full-sealing, achieve the protection level of IP67, which make sure the excellent working under the complicated operation condition.

1.2 Main Features

1.2.1 Support UDS diagnosis, with CAN wake-up function

1.2.2 Full-sealed process, can reliably work in the temperature of -40°C~55°C

1.2.3 Built-in thermal sensor, shut off when temperature up to 90°C

1.2.4 Protection level with IP67

2 Charger Technical Specification

2.1 Environmental Specification

▲Working environmental temperature

Area	Lowest Temperature	Highest Temperature
Global	-40°C	55°C

▲Storage environmental temperature

Area	Lowest Temperature	Highest Temperature
Global	-55°C	100°C

▲Humidity: relative humidity 5%~95%, no condensation

▲Altitude: ≤2000m

▲Working noisy: max when working ≤65dB, meet China standard QTC 895-2011

2.2 Charger regulatory requirements and reference

standards

The design and manufacture of this product must meet the related requirements of vehicle which applicable regulations and standards in China, reference standards as following:

No.	Standard Code	Standard Name	Remark
1	QC/T	Conductive on-board charger of electrical vehicle	/



2	GB/T 30512-2014	Prohibited substances requirement	/
3	GB/T 18387-2008	Limits and measurement methods for electromagnetic field emission intensity of electric vehicles, broadband, 9kHz~30MHz	/
4	GB/T 18384-2015	Safety requirements of electrical vehicle	/
5	GB/T 18487-2015	Electric vehicle conductive charging system	/
6	GB/T 28382-2012	Technical specifications for all-electric passenger vehicles	/
7	GB/T 14023-2011	Limits and methods of measurement for radio disturbance characteristics of vehicles, ships and installations driven by internal combustion engines	/
23	GB/T 18655-2018	EMC technical requirements for electronic components and subsystems of passenger vehicles	/
24	GB/T 18655-2010	Limits and measurement methods for the radio disturbance characteristics of vehicles, ships and internal combustion engines used to protect vehicle-mounted receivers	/



3 Charger Safety Regulations Specification

Grounding resistance test	@25A/AC	$\leq 100\text{m}\Omega$
Input insulation test	@1000V/DC	$\geq 20\text{M}\Omega$
Output insulation test	@1000V/DC	$\geq 20\text{M}\Omega$
Input withstand test	@2000V/AC 3S	Leak current $\leq 15\text{ma}$
Output withstand test	@2000V/AC 3S	Leak current $\leq 10\text{ma}$
Input to Output withstand test	@2000V/AC 3S	Leak current $\leq 10\text{ma}$

4 Charger Electrical Performance

4.1 Input

Input	Input voltage range	AC 90~265V
	Frequency	47~63Hz
	Input Current	$\leq 32\text{A}$
	Power Factor	$\geq 0.98 @ \geq 1650\text{W}$
	Efficiency	$\geq 93\%$ full loading
	Stand-by power consumption	$\leq 5\text{W}$
	Starting inrush current	$\leq 48\text{A}$

4.2 Output

Nominal Voltage		96V
Output	Output voltage range	45-177V
	Max output current	60A
	Output power	6600W@220VAC; 3300W@110VAC
	Output way	CV/CC
	Efficiency	≥93%
	CV accuracy	±1%
	CC accuracy	±2%
	Ripple voltage coefficient	±5%
	Output voltage rising time	< 5S, overshoot < 10%
	Shut off response time	Current decreased below 10% in 300ms, and decreased to 0A in 500ms

4.3 Low Voltage Output

Low voltage Output	Output way	CV
	Output voltage	12V
	Nominal current	5.5A
	CV accuracy	±2%
	Output Power	≤66W
	Ripple voltage coefficient	≤1%

4.4 Control Interface

Control interface	CC signal test	100Ω~10kΩ
	CP signal test	1%~99%, 5V~15V Vpp
	CC signal output	Optional for 220Ωand 680Ω
	Temperature test	Two ways input, support 1K and 10K
	12V wake-up input	≤10mA
	12V wake-up signal output	Max 0.2A
	12V CV	Sleep current≤1mA, peak current≤5A
	Electronic lock	Peak current 2.9A
	Electronic lock receiving signal	Switch volume
	CAN Communication	yes
	Baud rate	Optional for 125Kbps、250Kbps、500Kbps
	Terminal resistance	Not available

4.5 Other

EMI	Meet GB/T 18487.3-2001 11.3.1 and GB/T 18655-2018
EMD	Meet GB/T 18487.3-2001 11.3.2 and GB/T 18655-2018
Harmonic current	Meet GB 17625.1-2003 6.7.1.1
Protection level	IP67
Vibration resistance	10~25Hz swing 1.2mm, 25 – 500Hz 30 m/s^2 , 8hours each direction
Noisy	≤65dB (Class A)
MTBF	150000H

5 Charger Protection Functions

Protection functions	Input over-voltage protection	AC270±5V
	Input low-voltage protection	AC85±5V
	Output over-voltage protection	177V±5V
	Output low-voltage protection	45V±5V
	Over-temperature protection	Power start to decrease when internal temperature rise to 90°C, shut off when rise to 95°C
	Output short circuit protection	Stop output
	Output polarity reverse protection	yes
	Grounding protection	≤100mΩ
	CAN Communication protection	Automatically stop output when CAN communication fails
	Power-off protection	Yes

6 Interface

The interfaces in the charger can be grouped into two categories, one category is low voltage interface, the other is high voltage interface.

Low voltage interface includes control connector

High voltage interface includes AC220V input, DC output and HIVL

Connectors can be appointed by customer if quantity order is more than 5000pcs.

6.1 Low Voltage Connector and Pins Definition

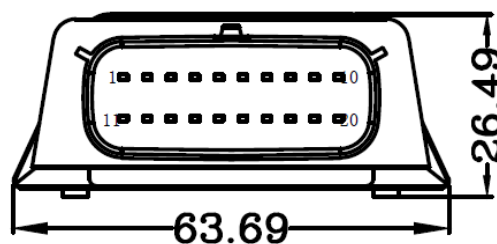

Pin	Definition	Comments	Note
10	12V 5A Positive		
11	CAN-H		
12	CAN-L		
13	HVIL+(High Voltage Internal Lock+)		
14	HVIL- (High Voltage Internal Lock-)		
17	12V 5A Negative		
Other	Reserved		

6.2 High Voltage Connectors and Pins Definition

6.2.1 AC Input

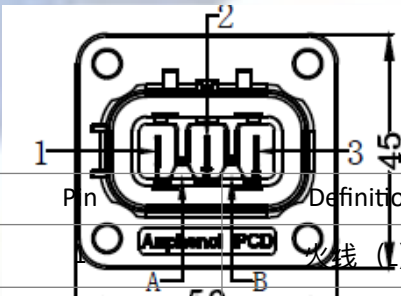

Brand	Pin	Definition
Amphenol	2	火线 (L)
		地线 (PE)
	3	零线 (N)
	A、B	HVIL

6.2.2 OBC Output

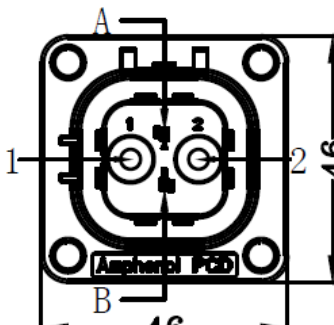

Brand	Pin	Definition

Amphenol	1	OBC output +
	2	Sharing -
	3	DC input +
	A、 B	HVIL

7.Size and Appearance

7.1.Size and weight

	Length (mm)	Width (mm)	Height (mm)	GW (KG)
Fan-cooled	312.8±3	268.4±3	111.2±3	≤8

7.2 Appearance

