

Haven 6-Piece U Sectional Teak Arm

Assembly Guide

neighbor

Frame Boxes

- ✓ Left Module - Teak Arm Frame (1)
- ✓ Right Module - Teak Arm Frame (1)
- ✓ Armless Module Frame (2)
- ✓ Corner Module Frame (2)

Cushion Boxes

- ✓ Cushions - Armless/Teak Arm (4)
- ✓ Cushions - Corner Module (2)

Parts



4X Module Bases

Left Module - Teak Arm Frame Box
Right Module - Teak Arm Frame Box
Armless Module Frame Box

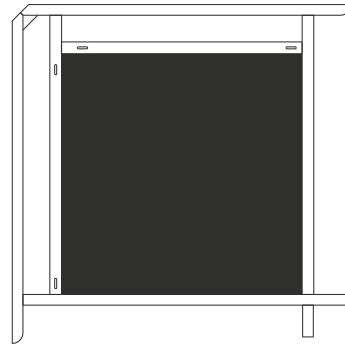

2X Corner Module Base

Corner Module Frame Box

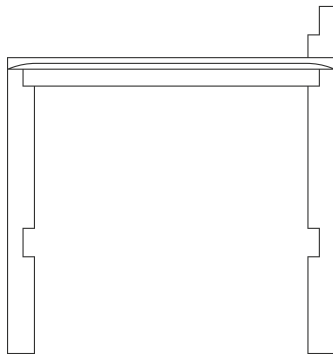

1X Right Teak Arm

Right Module - Teak Arm Frame Box

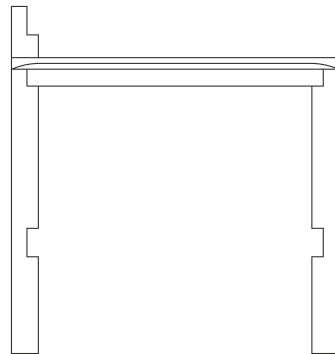

1X Left Teak Arm

Left Module - Teak Arm Frame Box

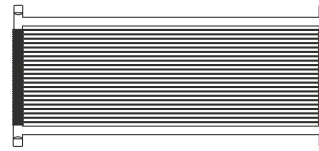

4X Module Roped Back

Left Module - Teak Arm Frame Box
Right Module - Teak Arm Frame Box
Armless Module Frame Box

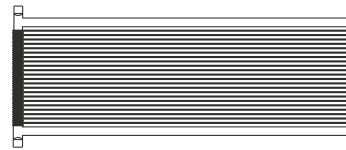

4X Corner Module Roped Back

Corner Module Frame Box

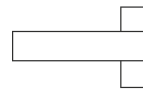

2X Short Corner Leg

Corner Module Frame Box

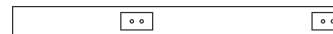

2X Long Corner Leg

Corner Module Frame Box



4X Module Back Support

Left Module - Teak Arm Frame Box
Right Module - Teak Arm Frame Box
Armless Module Frame Box

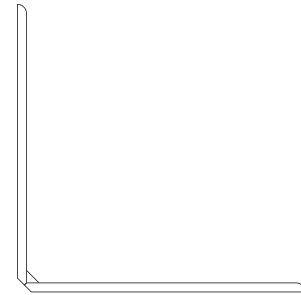

2X Corner Module Back Support

Corner Module Frame Box



1X Short Leg

Right Module - Teak Arm Frame Box
Armless Module Frame Box



5X Long Leg

Right Module - Teak Arm Frame Box
Armless Module Frame Box

Cushions



4X Module Base Cushion
Armless/Teak Arm Cushion Box

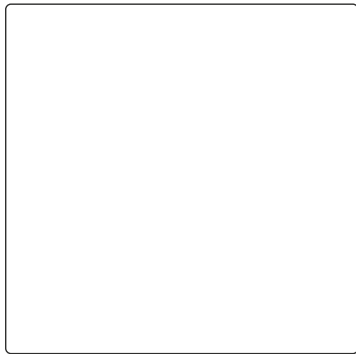

2X Corner Module Base Cushion
Corner Module Cushion Box

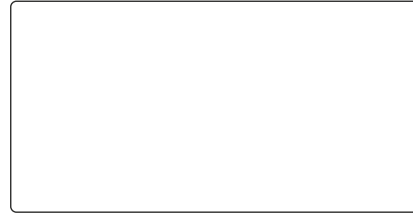

4X Module Back Cushion
Armless/Teak Arm Cushion Box



2X Long Corner Module Back Cushion
Corner Module Cushion Box

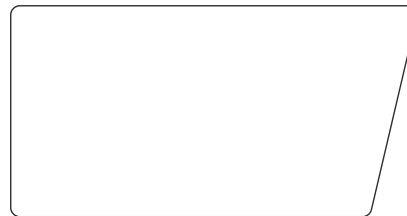

2X Small Corner Module Back Cushion
Corner Module Cushion Box

Hardware



68X 30mm Hex Bolt
All Frame Boxes



4X 40mm Hex Bolt
Left Module - Teak Arm Frame Box
Right Module - Teak Arm Frame Box

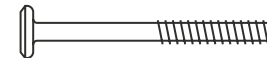

8X 60mm Hex Bolt
Corner Module Frame Box

Tools



Allen Wrench
All Frame Boxes

Assembly Tips

Use caution when lifting

Two-person lift is recommended. The boxes and product are both large and heavy.

Lay everything out before you begin

Getting familiar with all the components before assembly will make for a faster and easier assembly process.

Assemble on a soft surface

We recommend assembling your furniture on a soft surface such as a rug or a towel. The wood frame can scratch against harsh textures like brick or concrete.

Loose first, then tight

Partly tighten the hex bolts while assembly. After the modules are fully assembled, tighten the bolts firmly. Keep in mind humidity levels can slightly affect how the pieces fit together.

Product Care

Caring for teak

Unfinished teak will gradually change color from honey gold to a silver-gray patina. We encourage allowing the teak to turn color naturally and cleaning it annually or bi-annually. As for cleaning, we recommend Golden Teak Cleaner, which is specifically designed to kill mold and mildew spores inside teak.

Avoid prolonging mildew growth. If left in the shade for extended periods, this can be common. If you live in a particularly humid or rainy climate, keep a closer eye on mildew growth and clean as needed.

Covering your furniture when not in use will greatly prolong the lifespan of the wood.

Caring for Sunbrella

Brush off dirt before it becomes embedded in the fabric and wipe up spills as soon as they happen. Rinse thoroughly and air dry. Avoid scrubbing, stiff bristle brushes, or any other abrasive cleaning method.

Protect the area around your furniture when using bleach or other chemical solvents that may discolor non-Sunbrella fabrics.

If fabric is wrinkled, use an iron on the synthetic setting. As iron temperatures may vary, test a small area first before ironing the entire piece. Do not use a steamer or an iron set to the steam setting.

Fabric stain removal

- Blot (don't rub) liquid spills with a clean, dry cloth. For oil-based spills, apply an absorbent such as corn starch then remove with a straight edge.
- Spray on a mild cleaning solution of soap (such as Woolite® or Dawn®) and water and lightly agitate with a sponge or gentle brush.
- Rinse the fabric thoroughly to remove all soap residue.
- Air dry.
- As needed, unzip and machine-wash covers.

Corner/ Armless

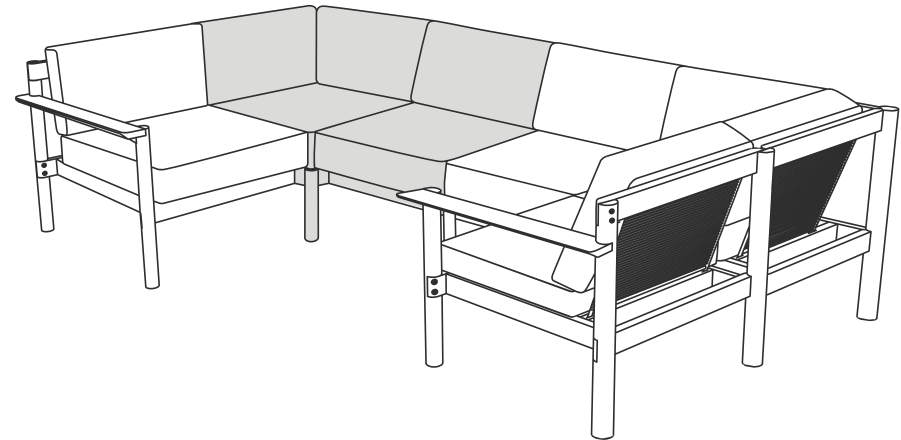

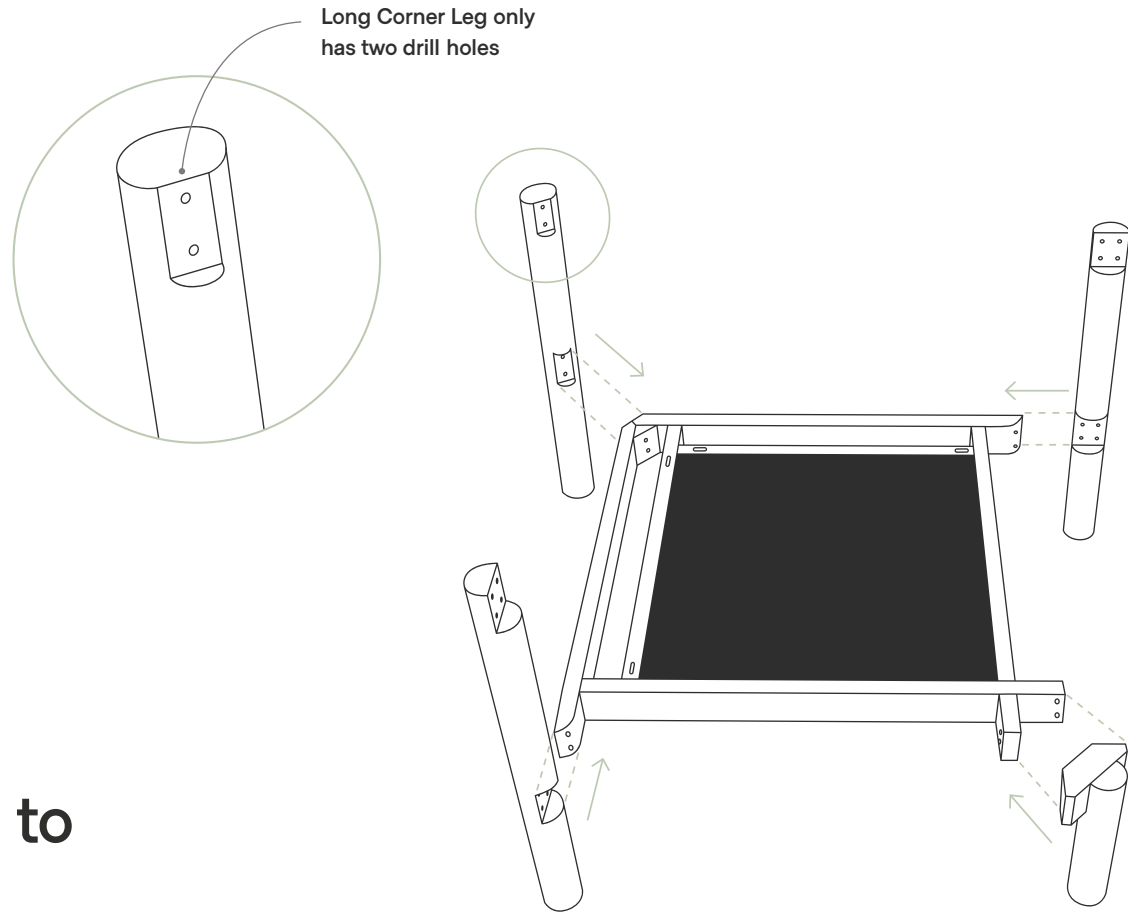

1

Connect legs to corner base

Gently connect the Long Corner Leg, two Long Legs, and the Short Corner Leg to the Corner Module Base.

4X 30mm Hex Bolt

2X 60mm Hex Bolt

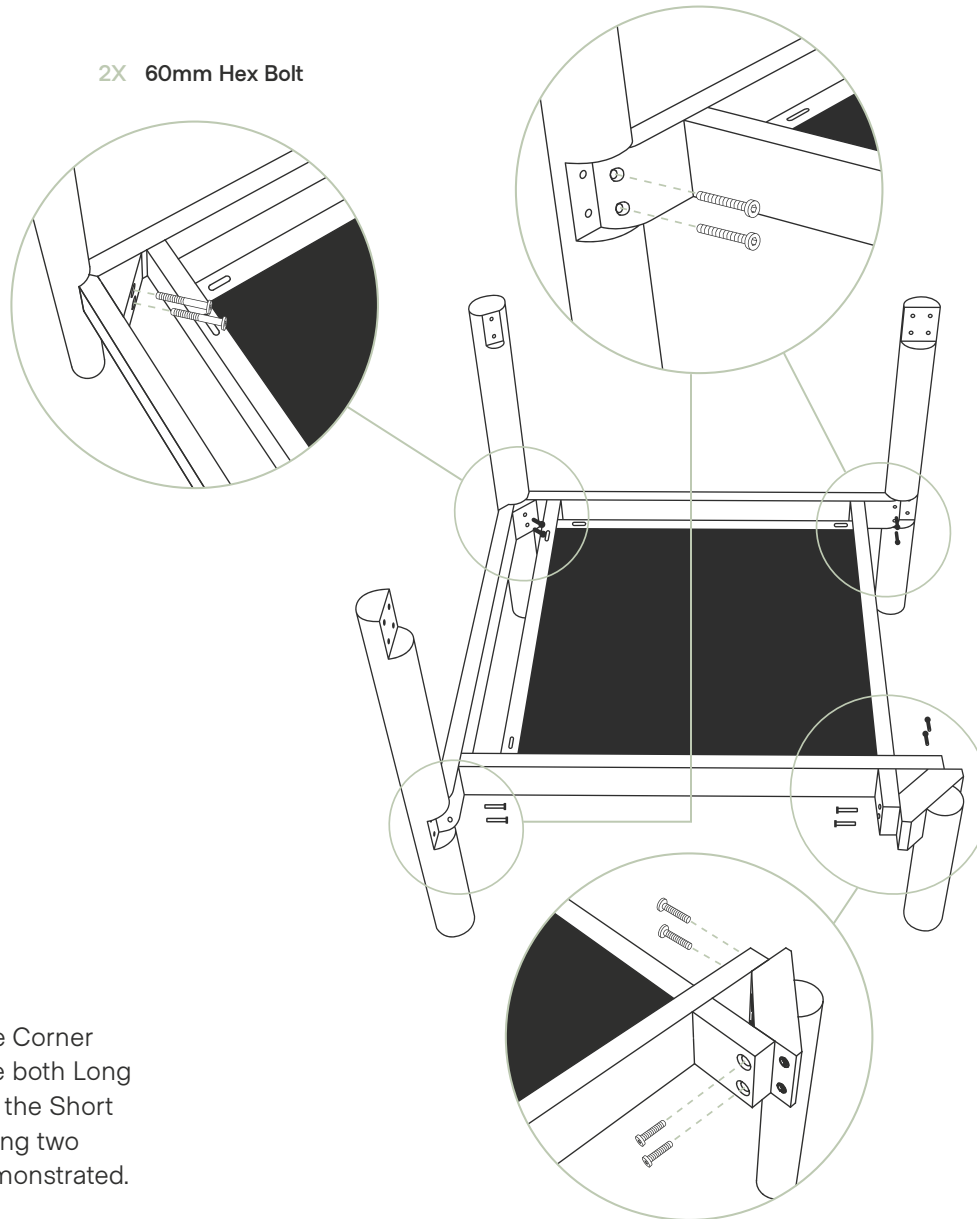

4X 30mm Hex Bolt

2 Fasten legs to corner base

Using the Allen Wrench provided, fasten the Corner Leg with two 60mm Hex Bolts. Then, secure both Long Legs with two 30mm Hex Bolts per leg and the Short Corner Leg with four 30mm Hex bolts, leaving two threaded holes on each leg exposed as demonstrated.

Backrest slots should align with the Long Leg, as shown

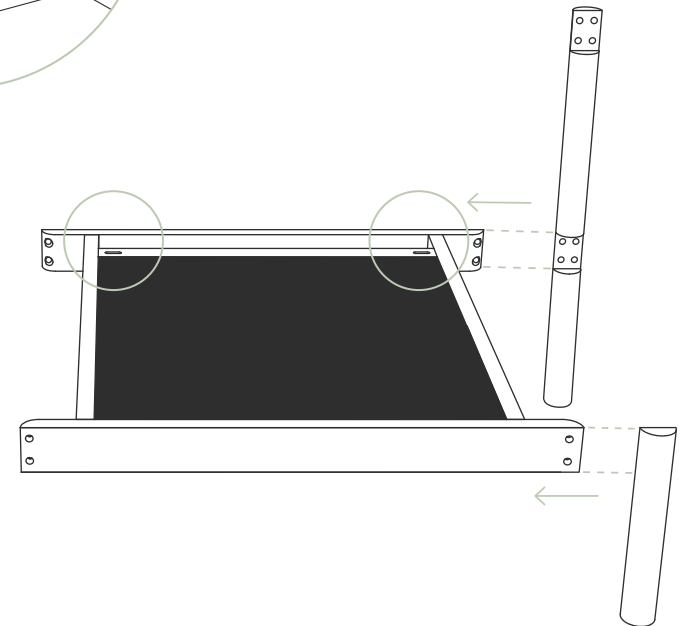
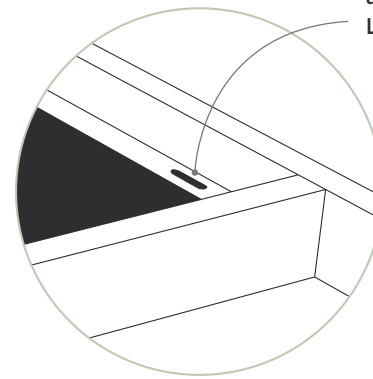

3

Connect legs to right side of base

Gently connect the Long and Short Legs to the right side of the Module Base, verifying that the backrest slots are aligned with the Long Leg.

2X 30mm Hex Bolt

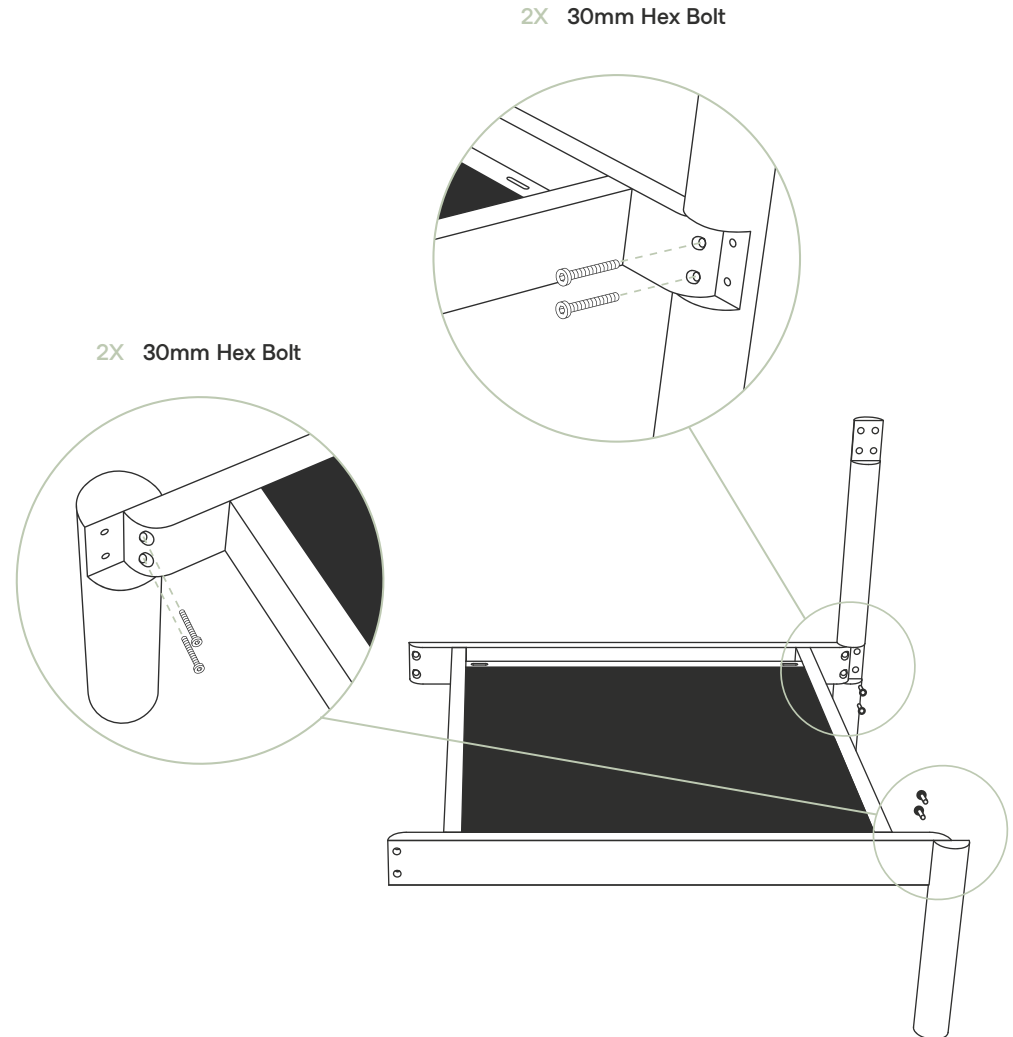

2X 30mm Hex Bolt

4

Fasten legs to base

With the Allen Wrench provided, fasten the Short Leg to the Module Base with two 30mm Hex Bolts. Repeat with Long Leg. Be sure to leave two threaded holes on each leg exposed as demonstrated.

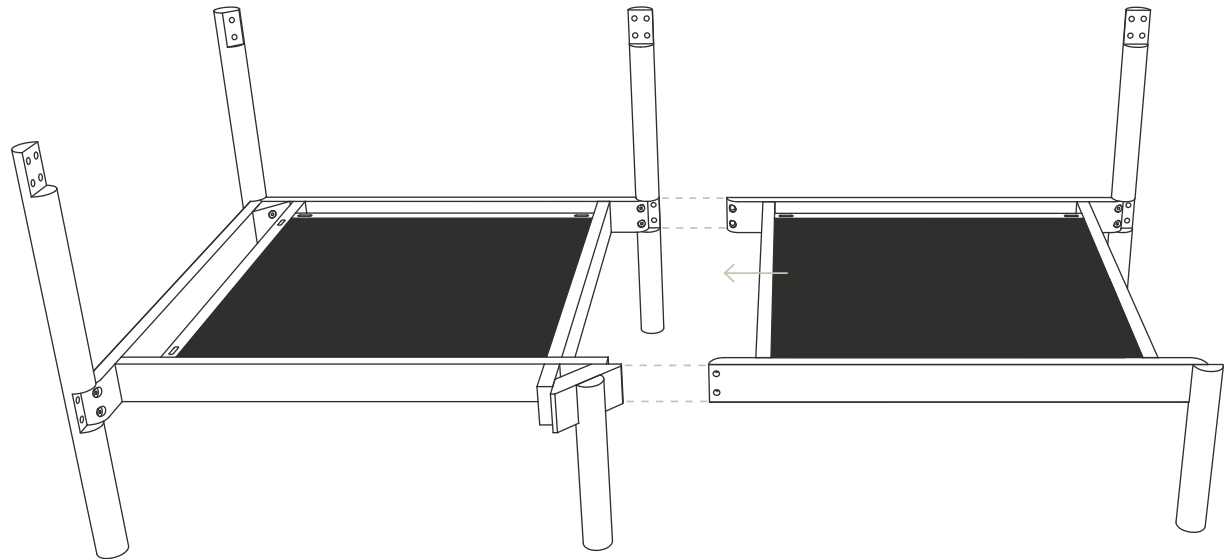

5

Connect bases

Gently slide Module Base into the slotted sections on the assembled corner component's Long and Short Legs. Slide base until its pre-drilled holes align with the threaded holes on the legs.

2X 30mm Hex Bolt

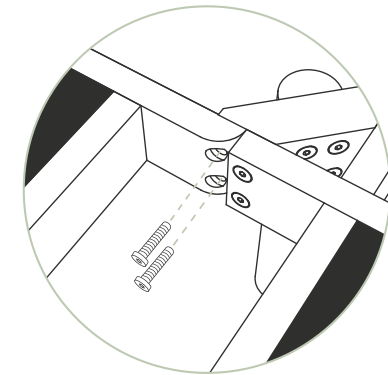
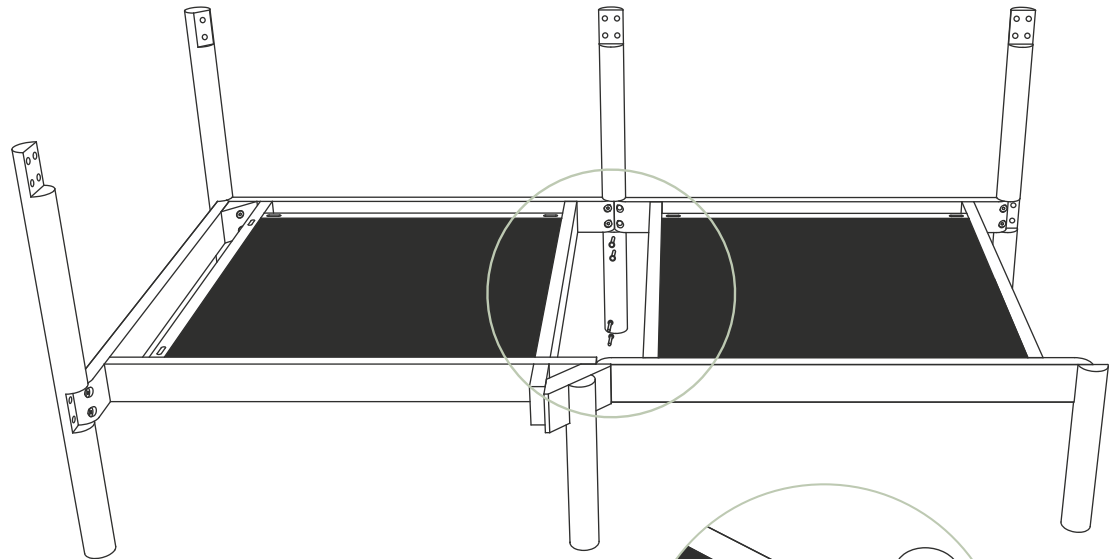
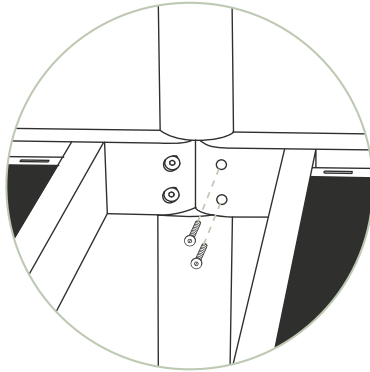

2X 30mm Hex Bolt

6

Fasten bases

After holes on the bases are aligned with the corresponding threaded holes on each leg, use the Allen Wrench provided to fasten them together with two 30mm Hex Bolts per side.

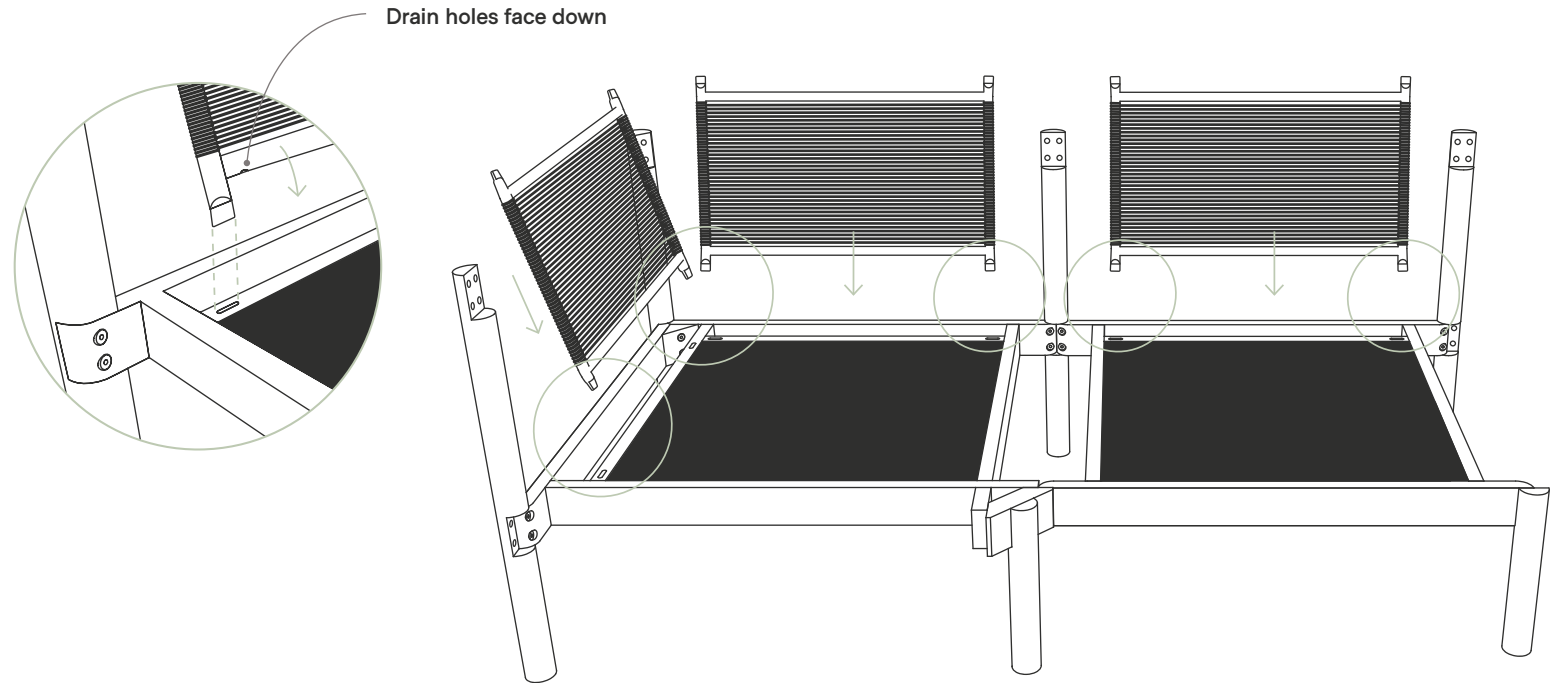

7

Secure roped backs to bases

Insert the Module Roped Back into the slots of the Module Base. Then, insert the Corner Module Roped Backs into the slots of the Corner Module Base.

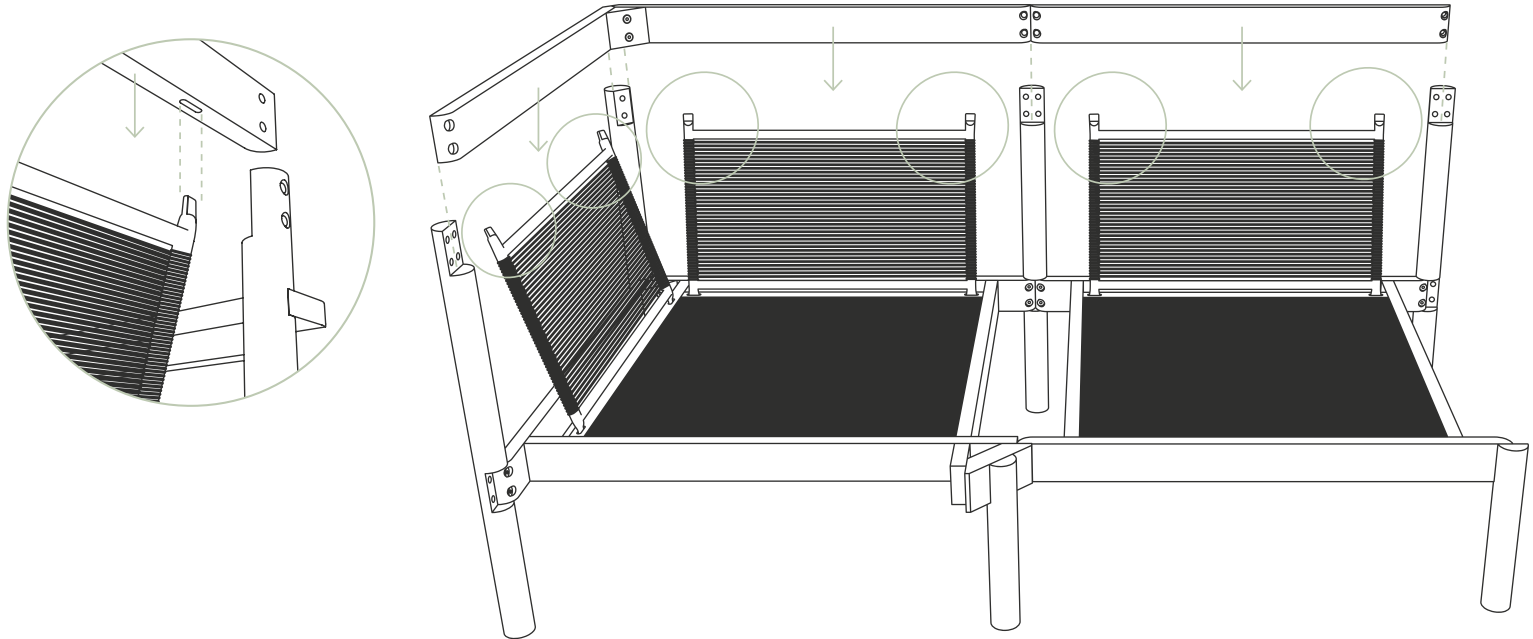

Attach back supports to roped backs

Lower the Module Back Support onto the Module Roped back and the Corner Module Back Support onto the Corner Module Roped Backs. Fit the tabs into their corresponding slots, then insert.

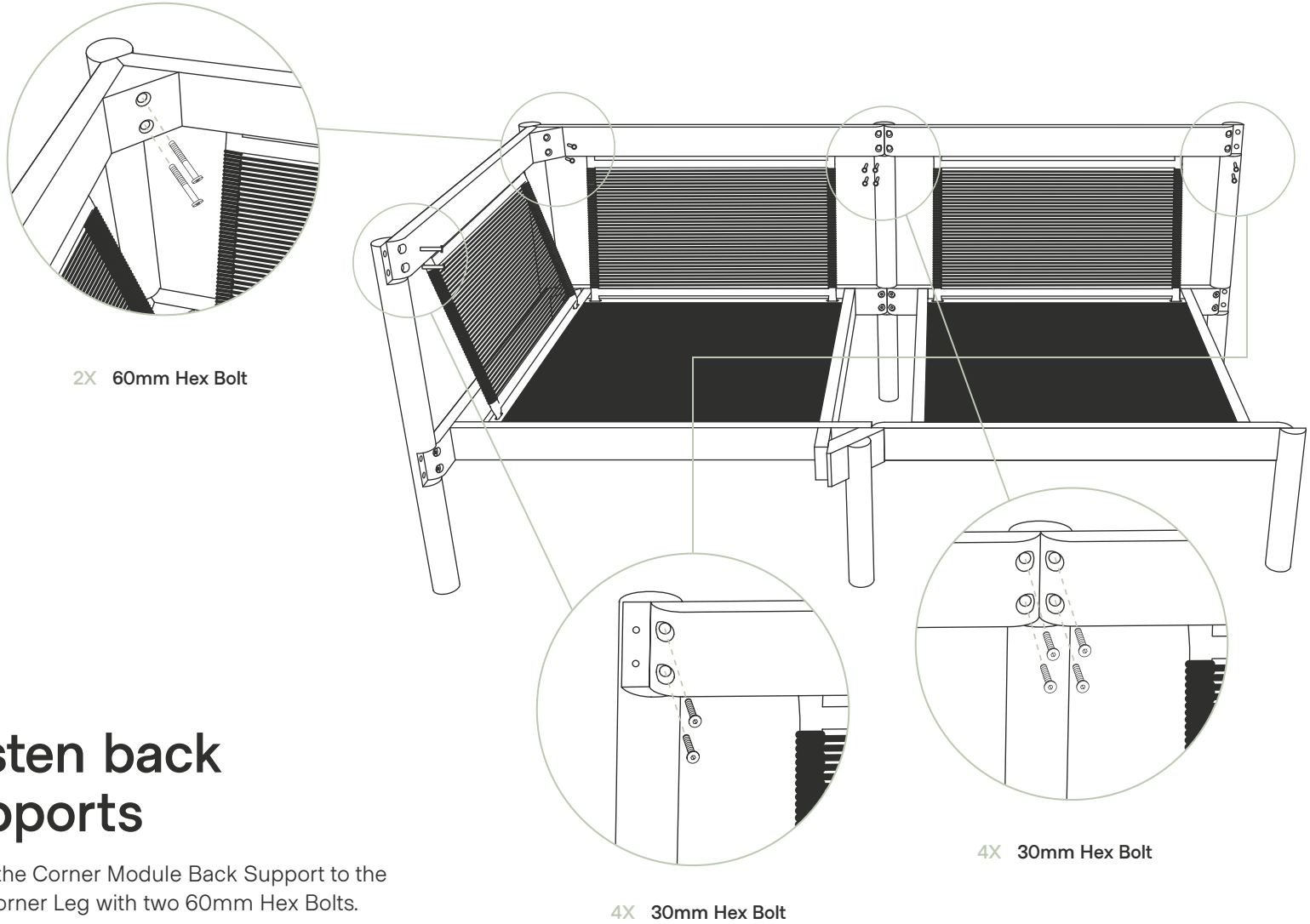

9

Fasten back supports

Fasten the Corner Module Back Support to the Long Corner Leg with two 60mm Hex Bolts. Then, fasten the back supports to the three remaining Long Legs with eight 30mm Hex Bolts.

Armless/ Corner

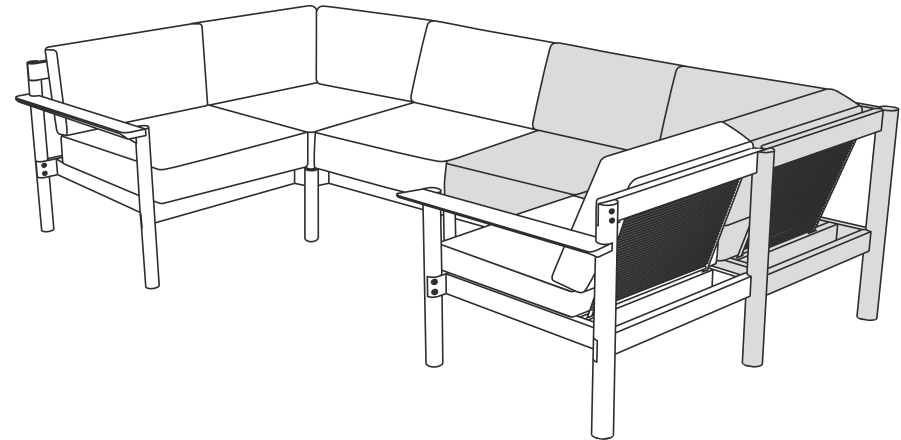

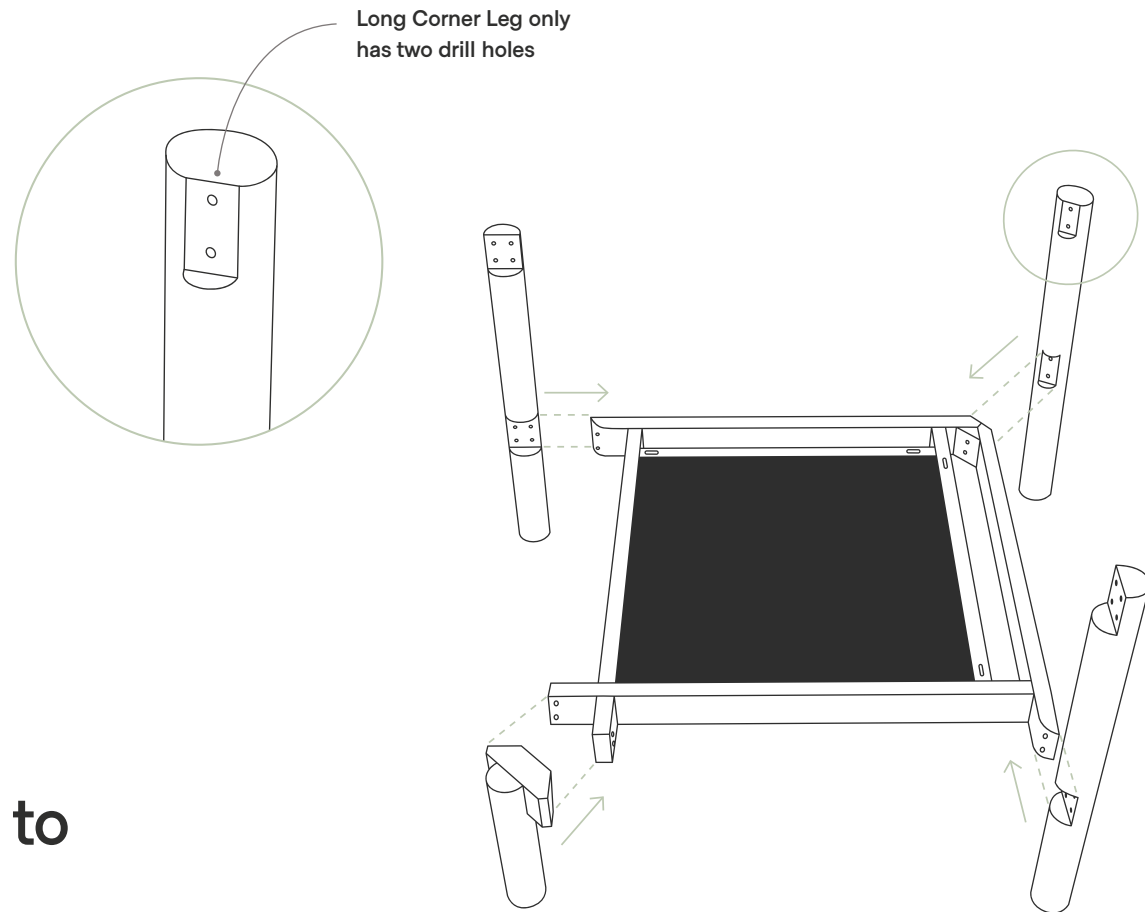

1

Connect legs to corner base

Gently connect the Long Corner Leg, two Long Legs, and the Short Corner Leg to the Corner Module Base.

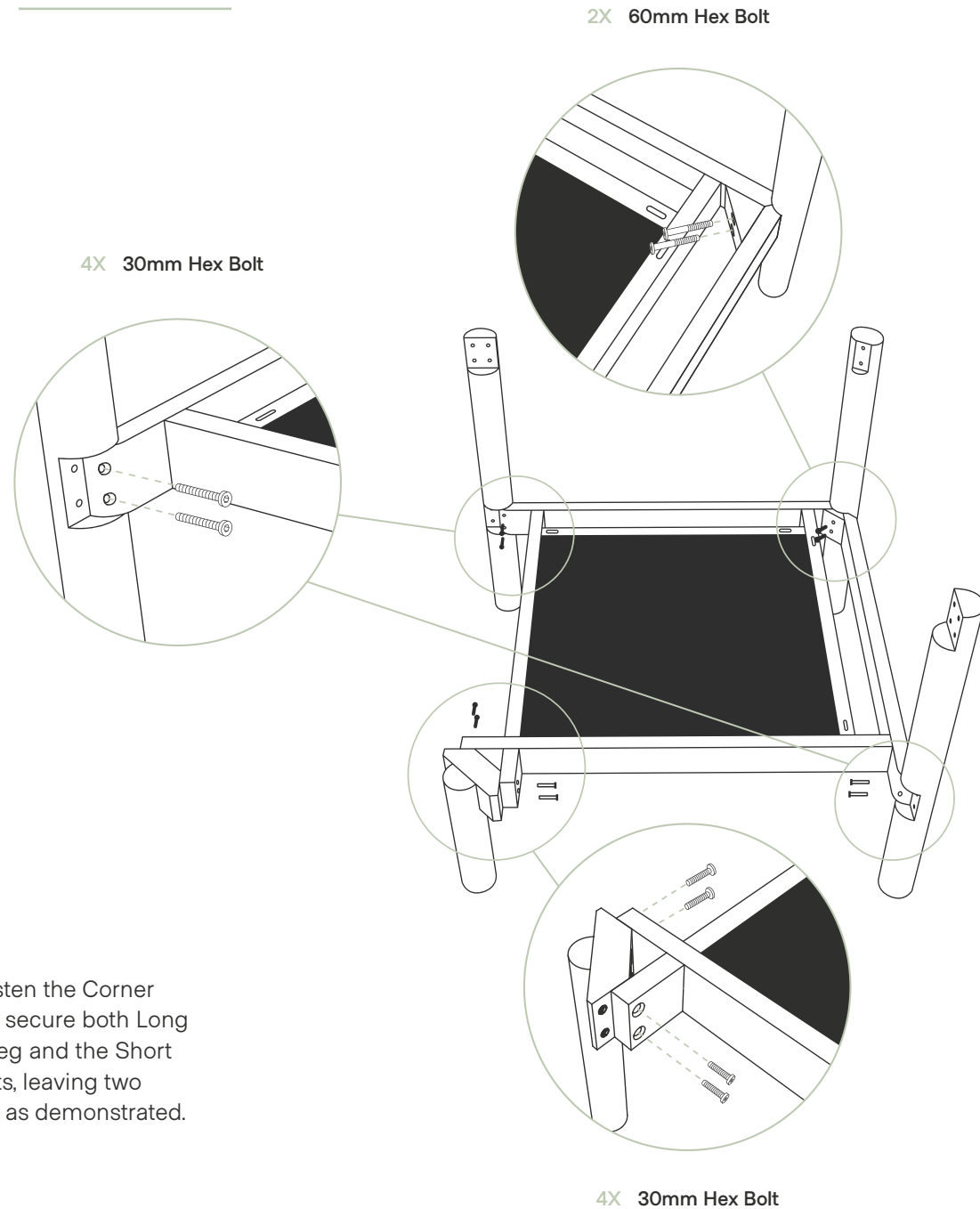

2

Fasten legs to corner base

Using the Allen Wrench provided, fasten the Corner Leg with two 60mm Hex Bolts. Then, secure both Long Legs with two 30mm Hex Bolts per leg and the Short Corner Leg with four 30mm Hex bolts, leaving two threaded holes on each leg exposed as demonstrated.

3

Connect legs to left side of base

Gently connect the Long and Short Legs to the left side of the Module Base, verifying that the backrest slots are aligned with the Long Leg.

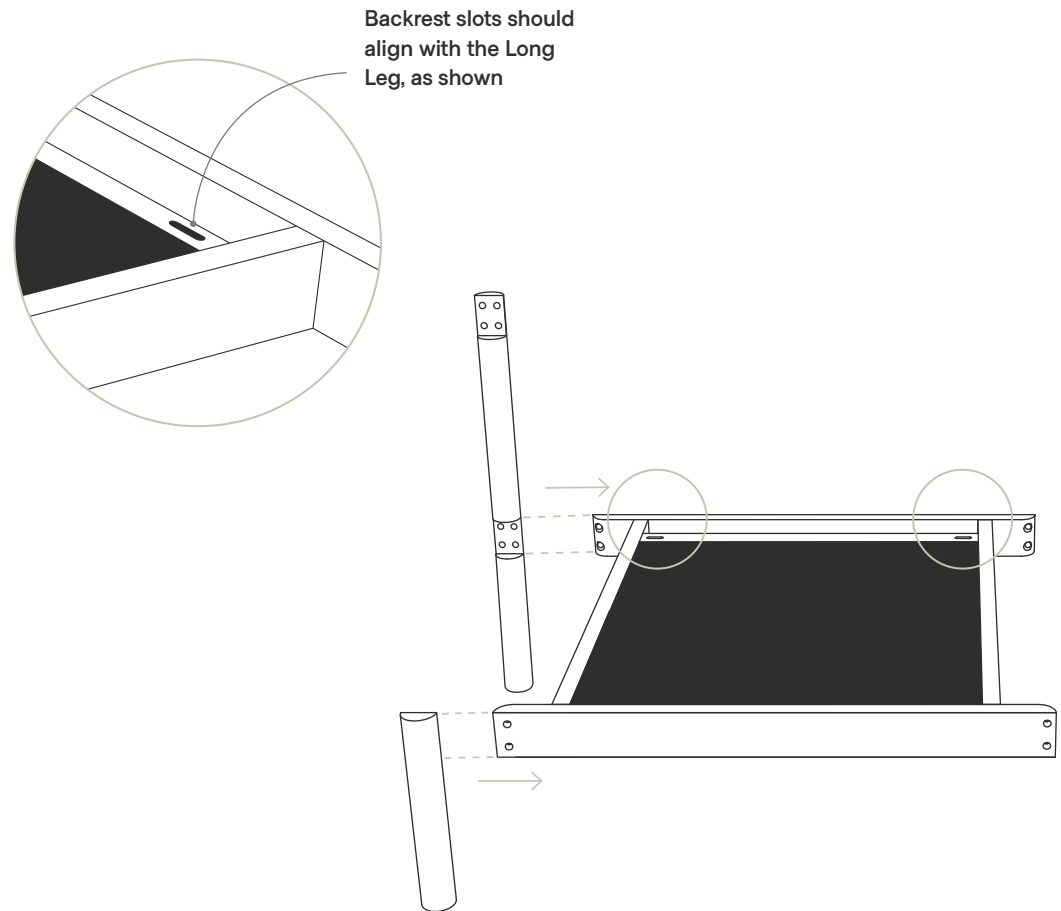

2X 30mm Hex Bolt

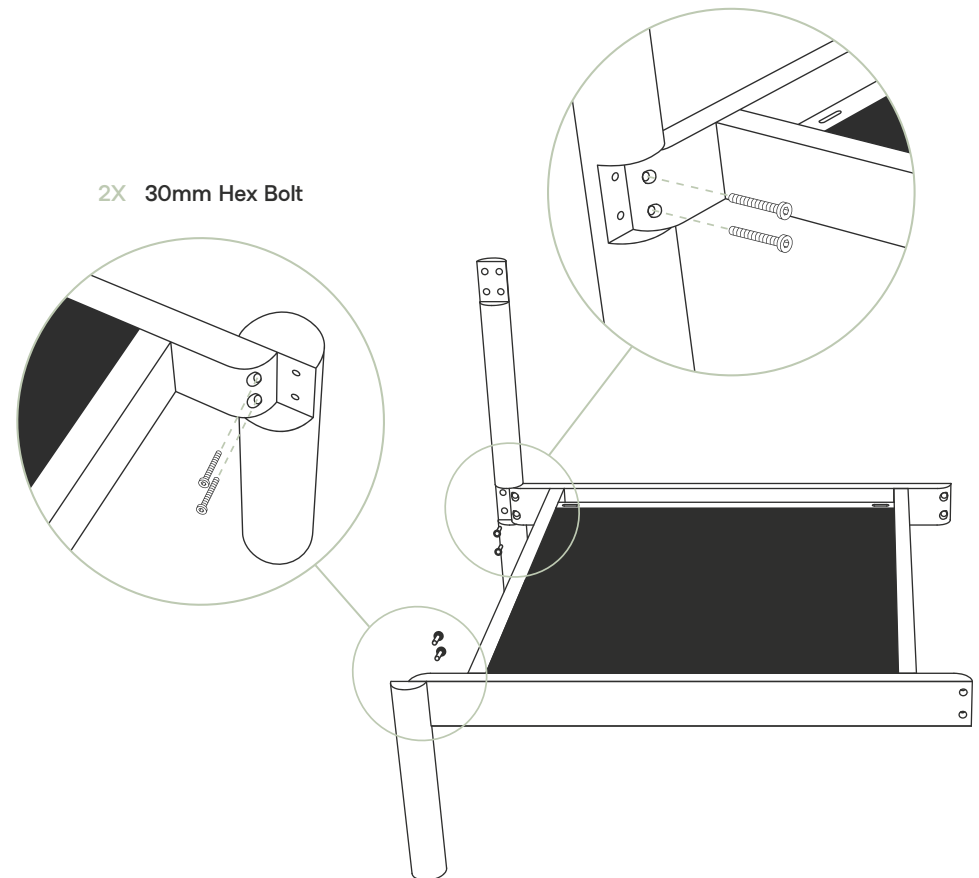

2X 30mm Hex Bolt

4

Fasten legs to base

With the Allen Wrench provided, fasten the Short Leg to the Module Base with two 30mm Hex Bolts. Repeat with Long Leg. Be sure to leave two threaded holes on each leg exposed as demonstrated.

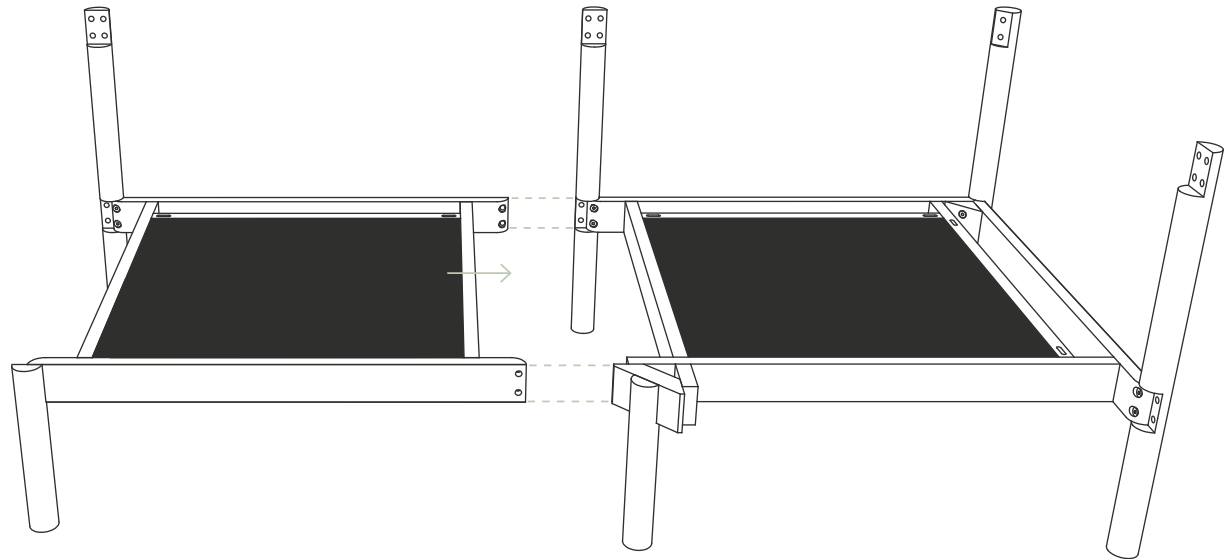

5

Connect bases

Gently slide Module Base into the slotted sections on the assembled corner component's Long and Short Legs. Slide base until its pre-drilled holes align with the threaded holes on the legs.

2X 30mm Hex Bolt

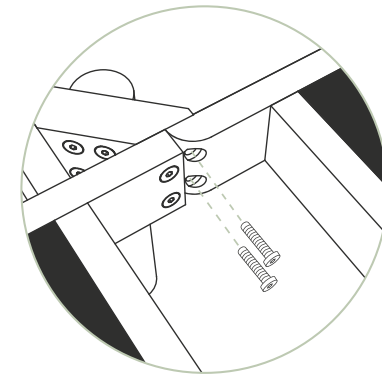
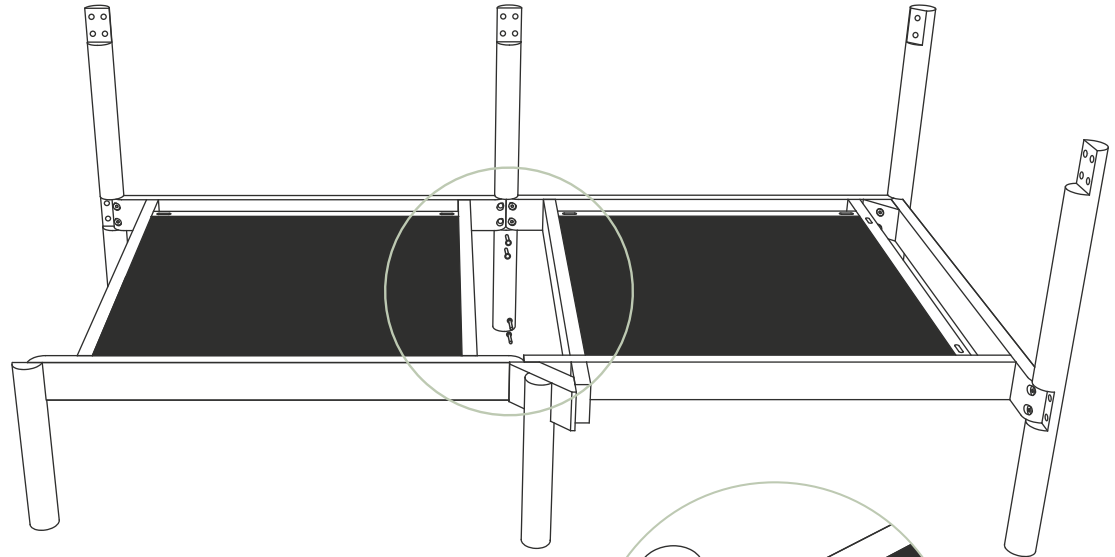
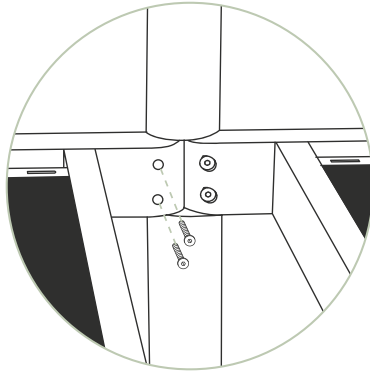

2X 30mm Hex Bolt

6

Fasten bases

After holes on the bases are aligned with the corresponding threaded holes on each leg, use the Allen Wrench provided to fasten them together with two 30mm Hex Bolts per side.

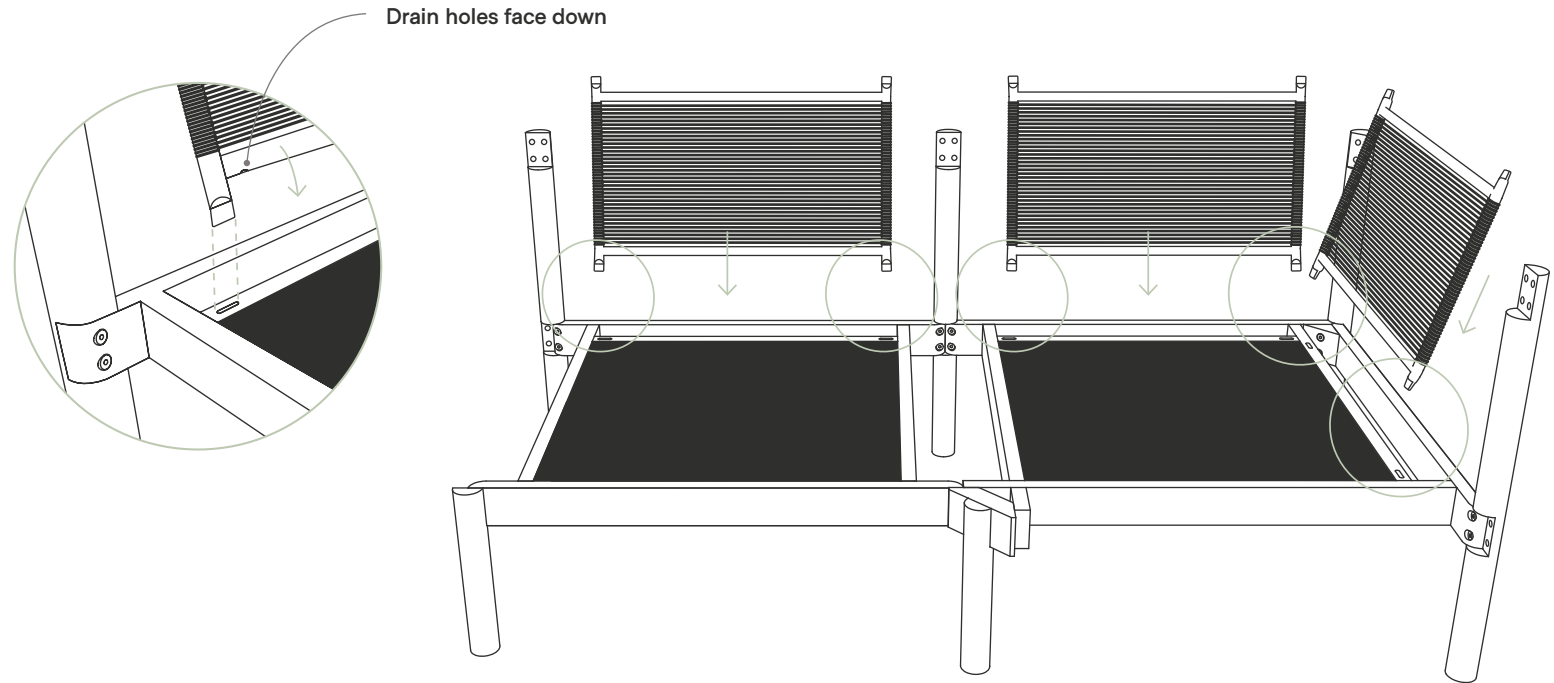

7

Secure roped backs to bases

Insert the Module Roped Back into the slots of the Module Base. Then, insert the Corner Module Roped Backs into the slots of the Corner Module Base.

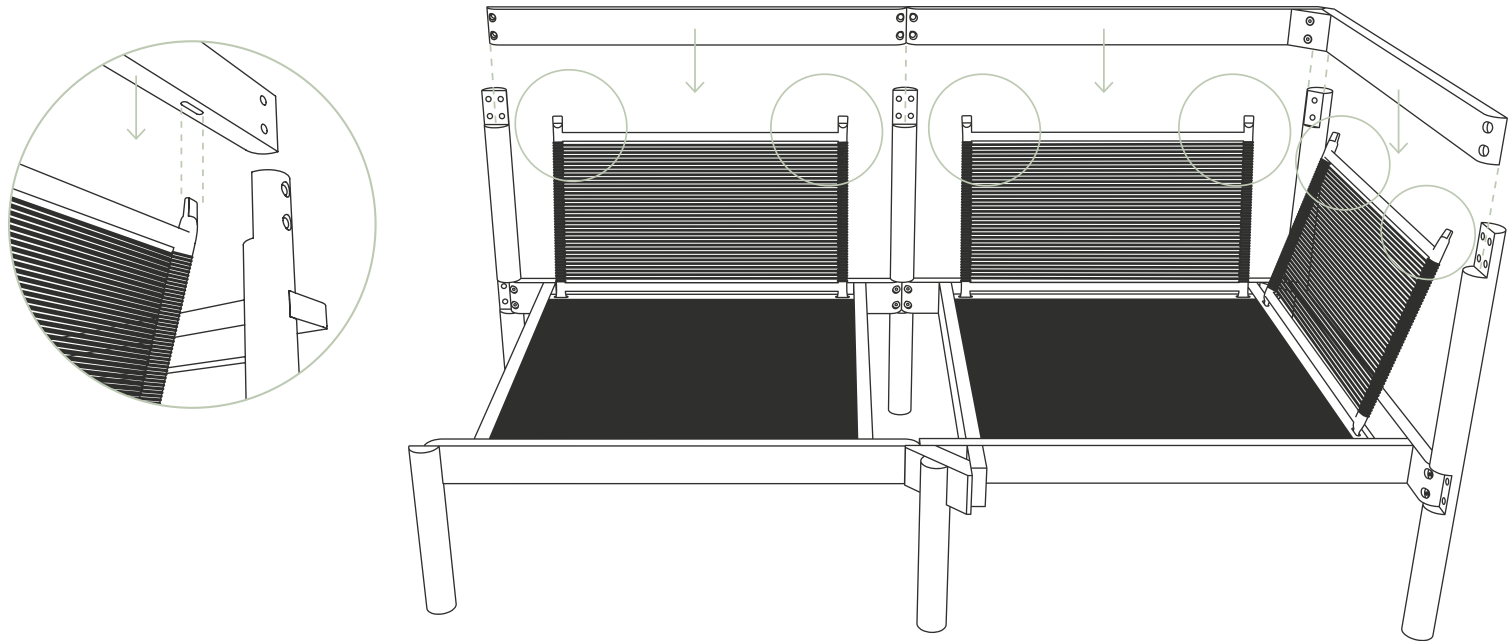

Attach back supports to roped backs

Lower the Module Back Support onto the Module Roped back and the Corner Module Back Support onto the Corner Module Roped Backs. Fit the tabs into their corresponding slots, then insert.

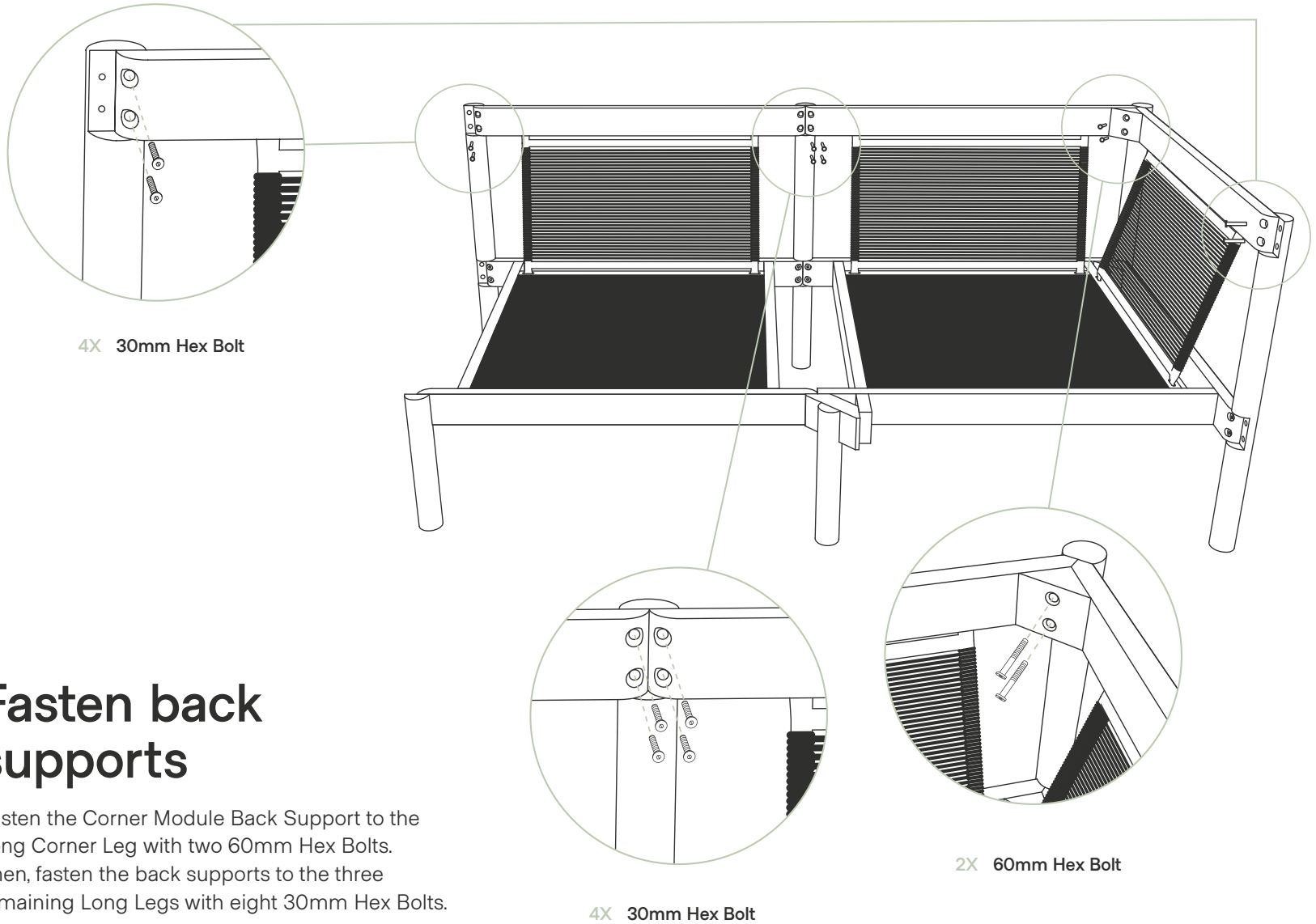

9

Fasten back supports

Fasten the Corner Module Back Support to the Long Corner Leg with two 60mm Hex Bolts. Then, fasten the back supports to the three remaining Long Legs with eight 30mm Hex Bolts.

Left Arm

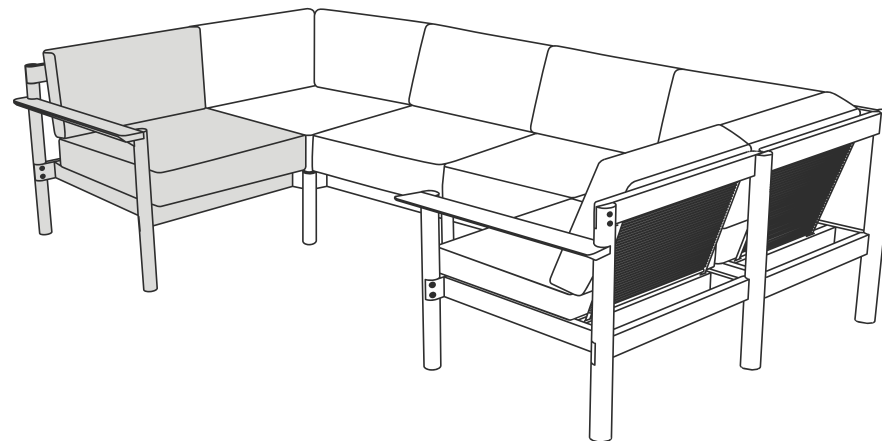

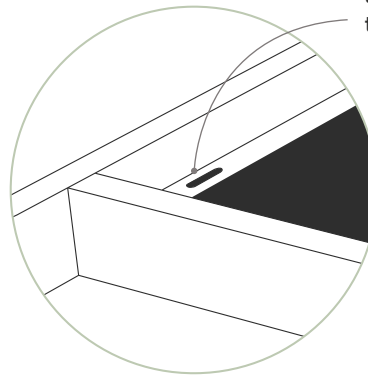

Backrest slots should align with the back of the armrest, as shown

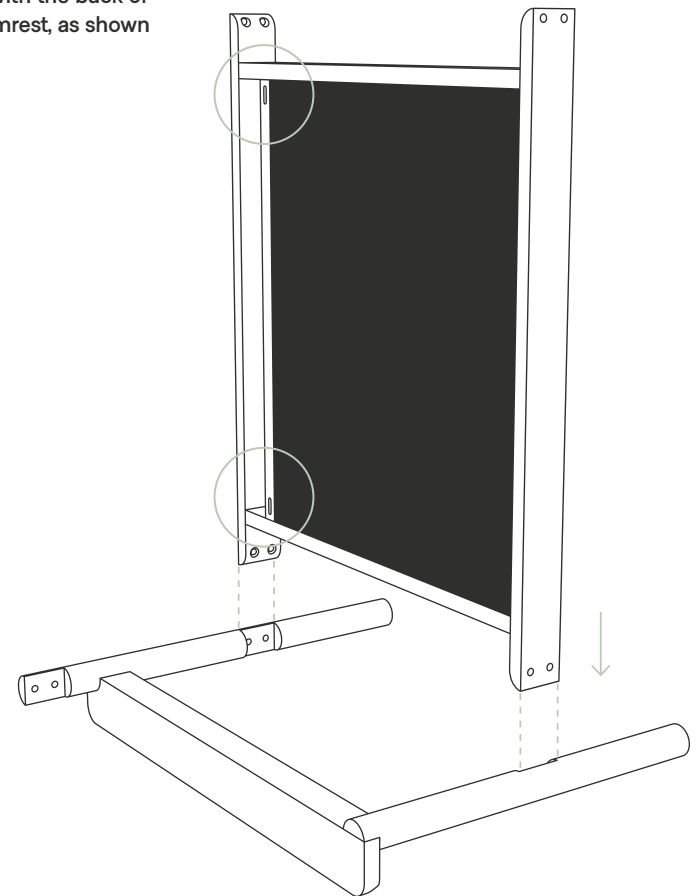

1

Connect base to left arm

Place the Left Teak Arm on a soft surface with the armrest facing down. Gently insert the Module Base into the arm's inner slots.

4X 30mm Hex Bolt

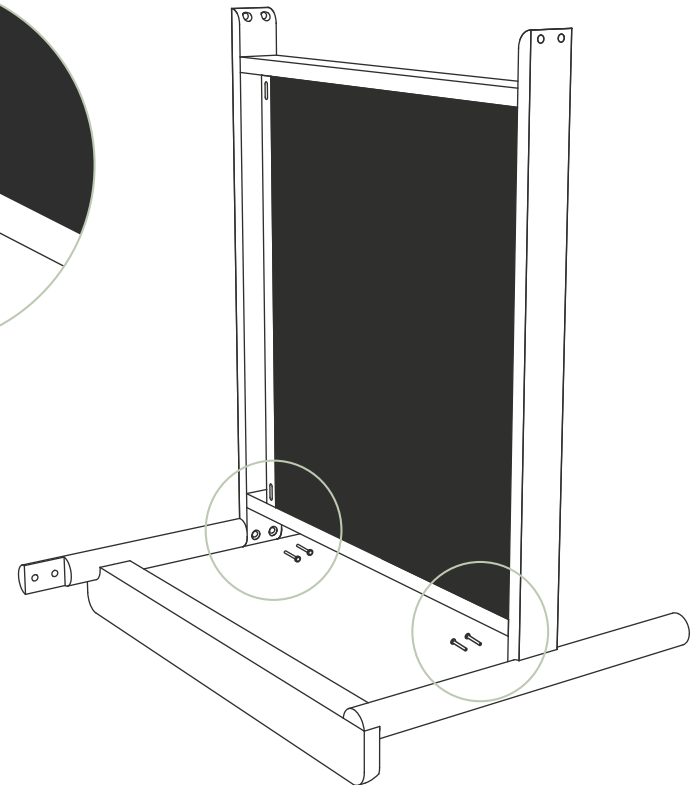
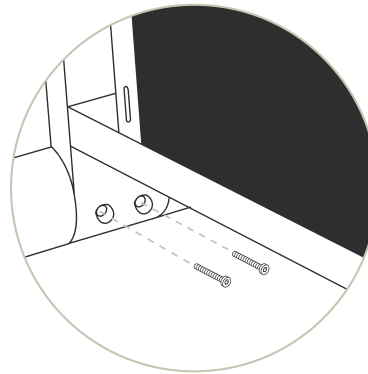

2 Fasten arm to base

Using the Allen Wrench provided, fasten the Module Base to the Left Teak Arm with two 30mm Hex Bolts per side.

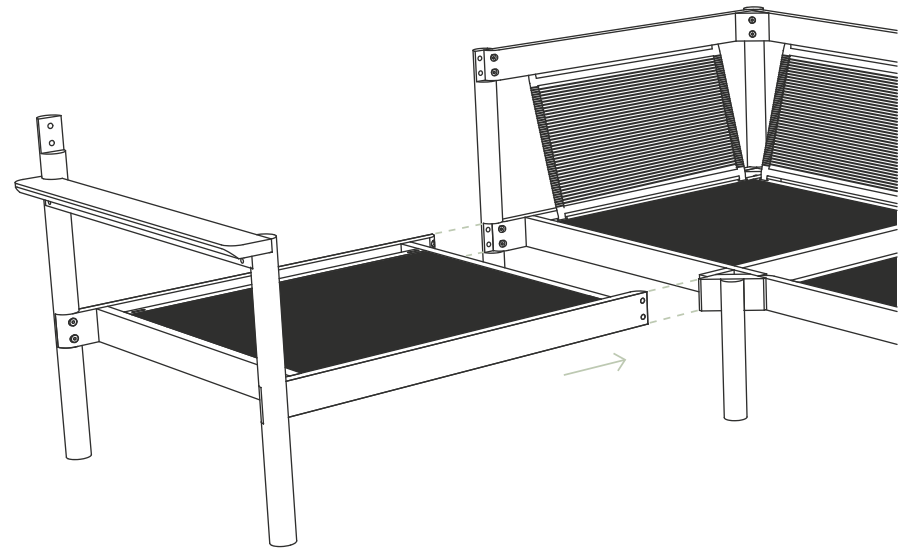

3 Connect base to corner

Gently slide the assembled components into the corner component. Slide base until its pre-drilled holes align with the threaded holes on the legs.

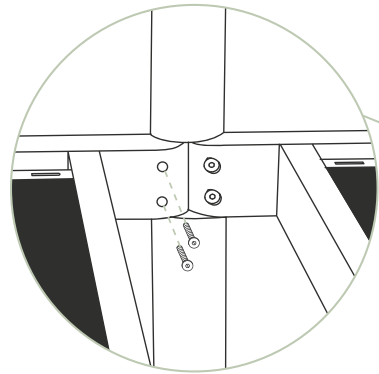

2X 30mm Hex Bolt

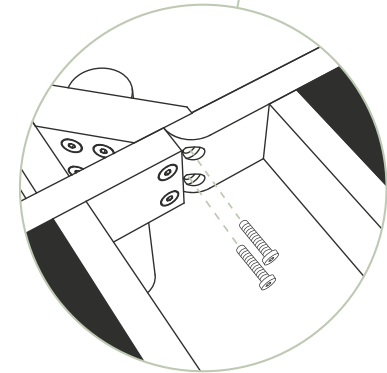
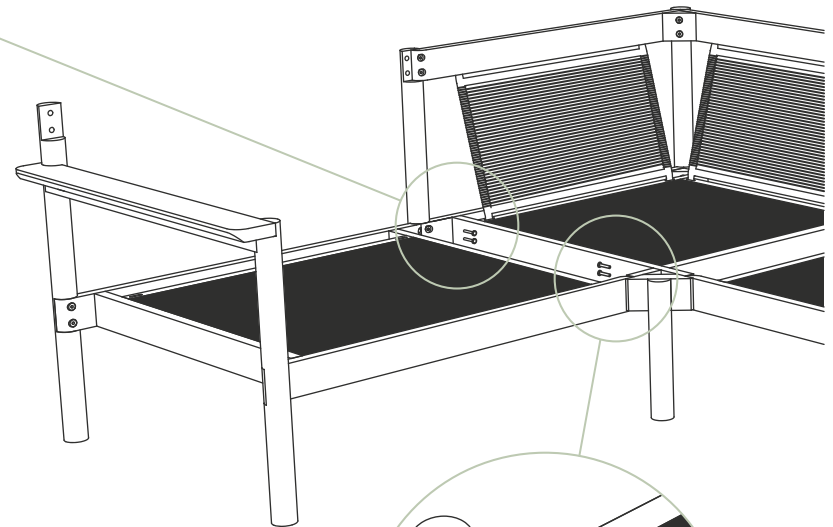

2X 30mm Hex Bolt

4

Fasten bases

After holes on the bases are aligned with the corresponding threaded holes on each leg, use the Allen Wrench provided to fasten them together with two 30mm Hex Bolts per side.

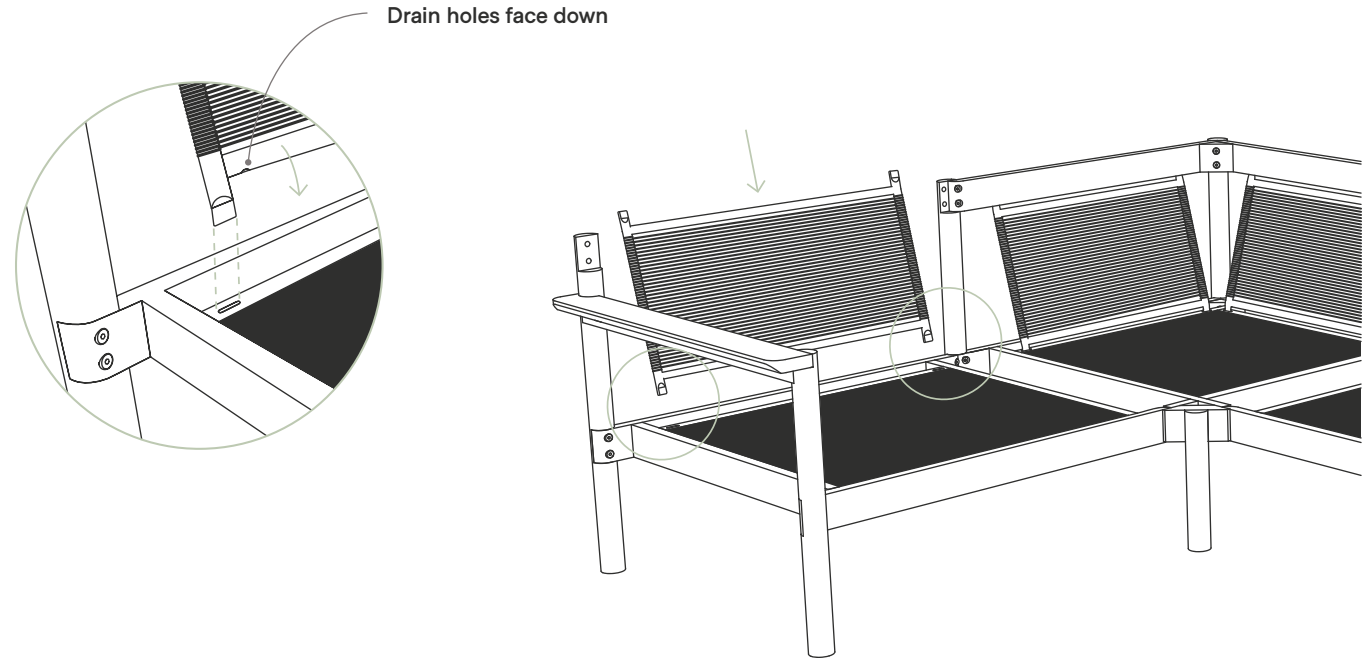

5

Secure roped back to base

Insert the Module Roped Back into the slots of the Module Base.

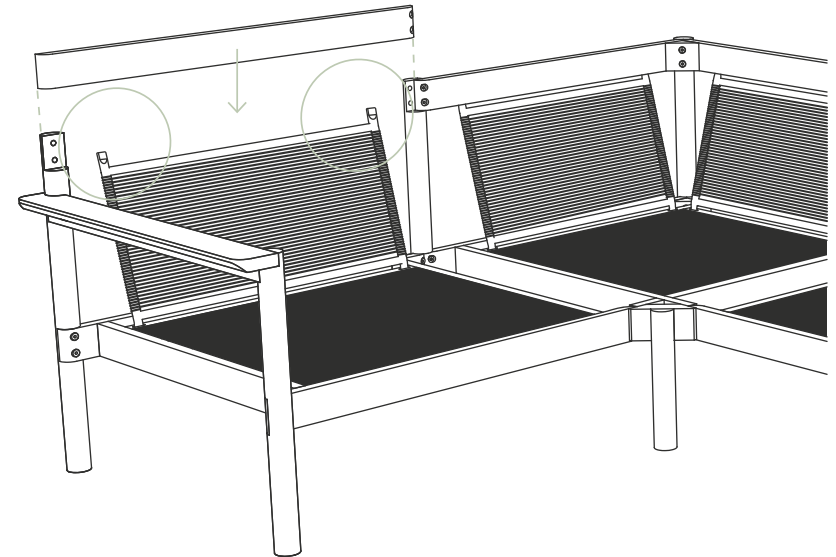
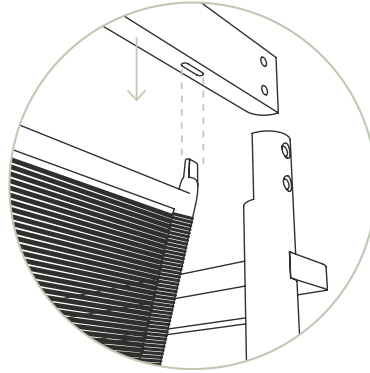

6 Attach back support to roped back

Lower the Module Back Support onto the Module Roped Back by fitting the tabs into their corresponding slots, then insert.

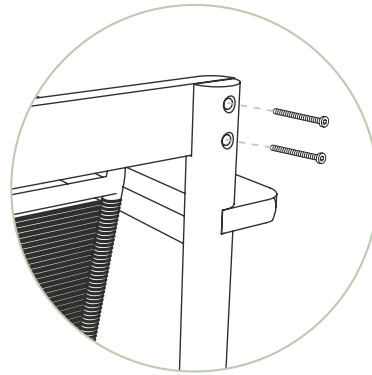

2X 40mm Hex Bolt

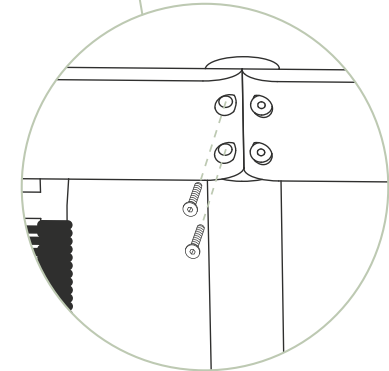
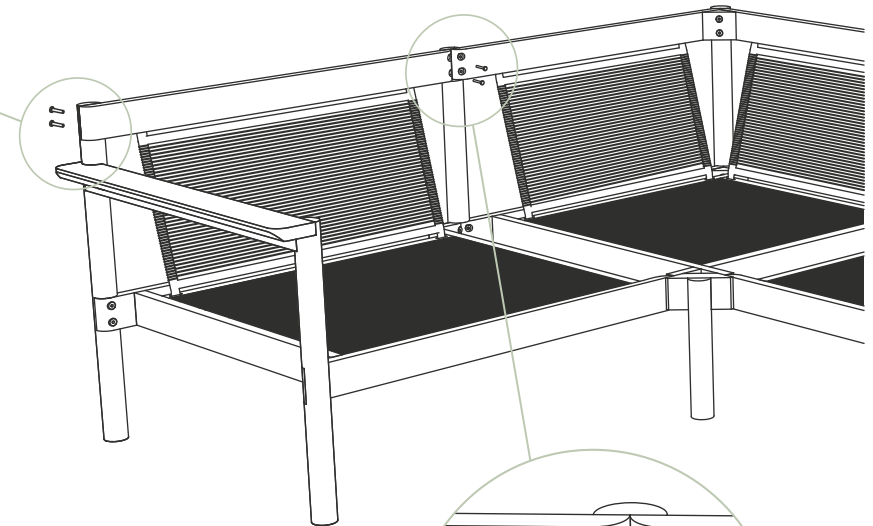

2X 30mm Hex Bolt

7

Fasten back support

Fasten the Module Back Support to the Long Leg with two 30mm Hex Bolts. Then, fasten to the Teak Arm with two 40mm Hex Bolts.

Right Arm

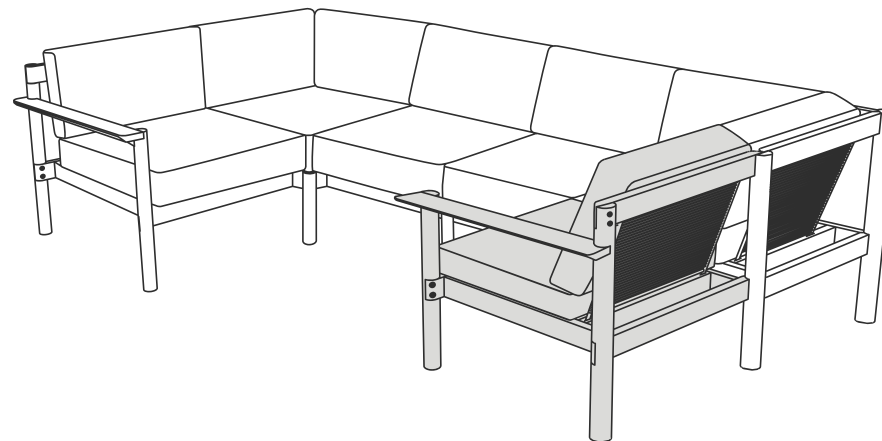

Backrest slots should align with the back of the armrest, as shown

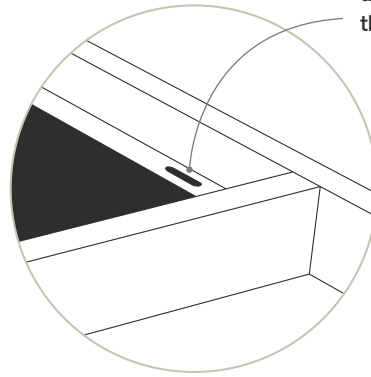

1

Connect base to right arm

Place the Right Teak Arm on a soft surface with the armrest facing down. Gently insert the Module Base into the arm's inner slots.

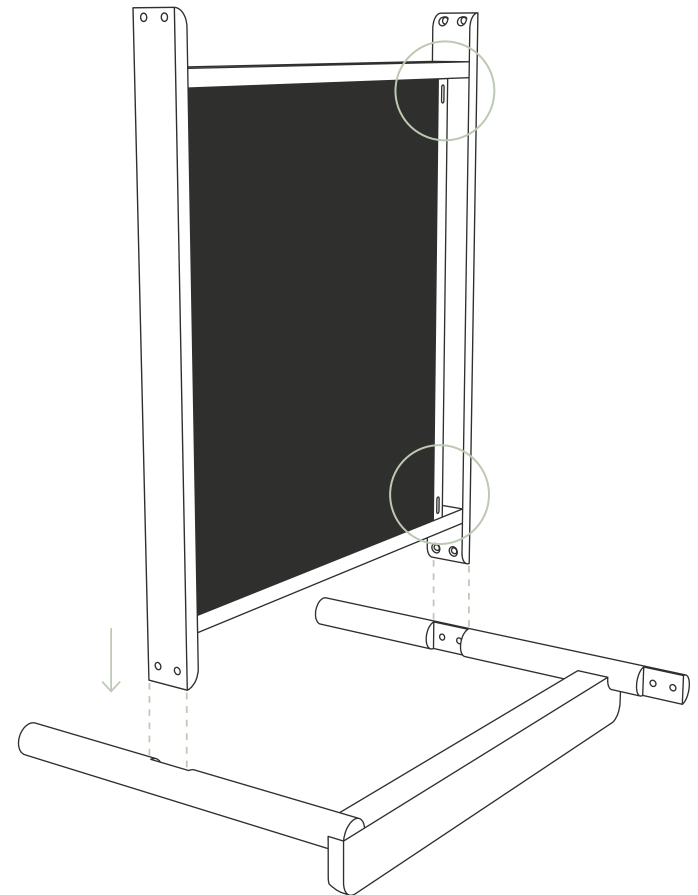

4X 30mm Hex Bolt

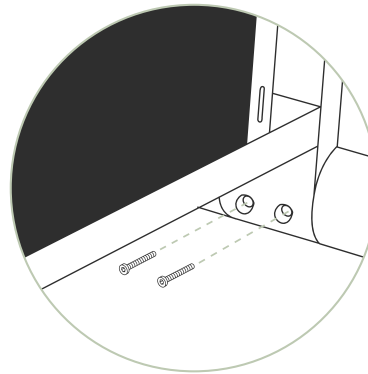

2 Fasten arm to base

Using the Allen Wrench provided, fasten the Module Base to the Right Teak Arm with two 30mm Hex Bolts per side.

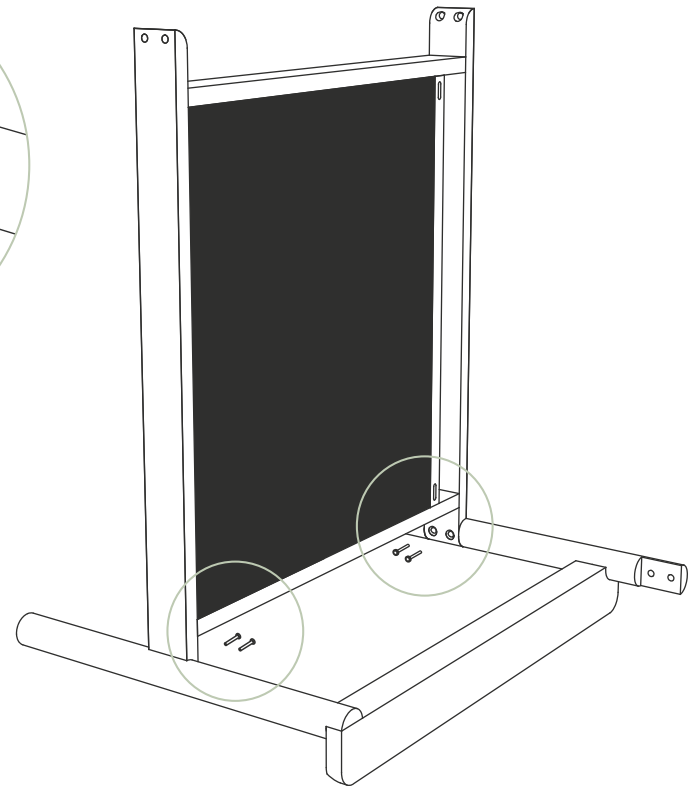

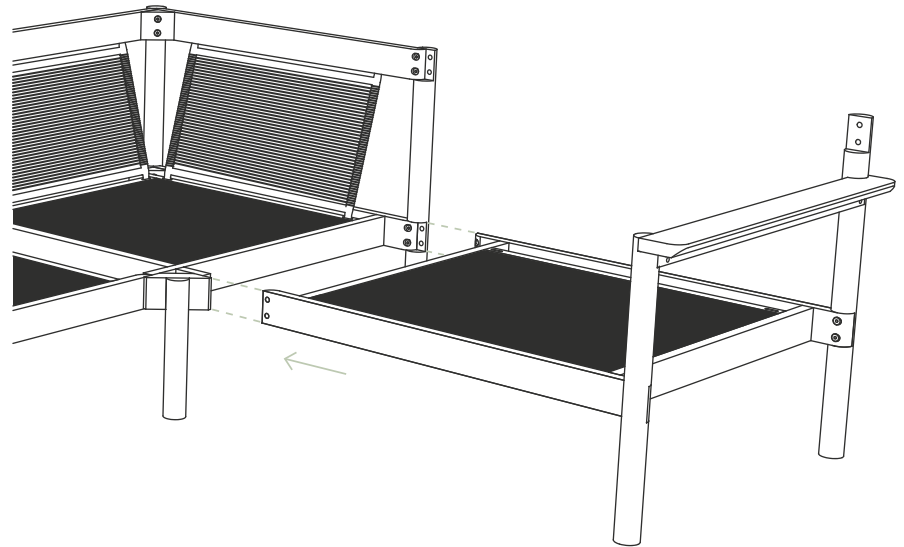

3 Connect base to corner

Gently slide the assembled components into the corner component. Slide base until its pre-drilled holes align with the threaded holes on the legs.

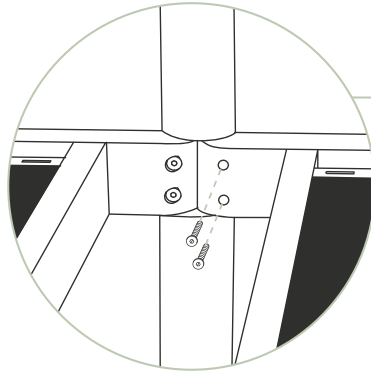

2X 30mm Hex Bolt

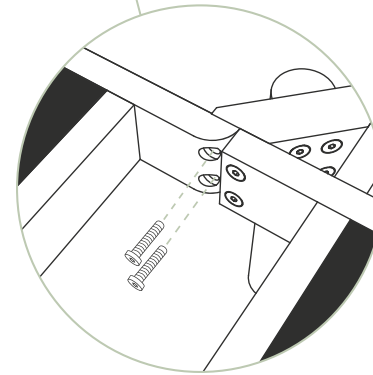
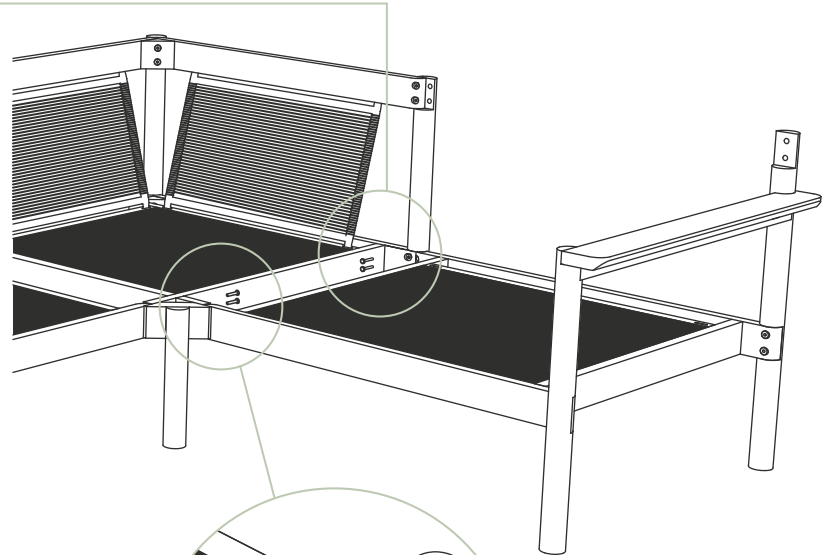

2X 30mm Hex Bolt

4

Fasten bases

After holes on the bases are aligned with the corresponding threaded holes on each leg, use the Allen Wrench provided to fasten them together with two 30mm Hex Bolts per side.

Drain holes face down

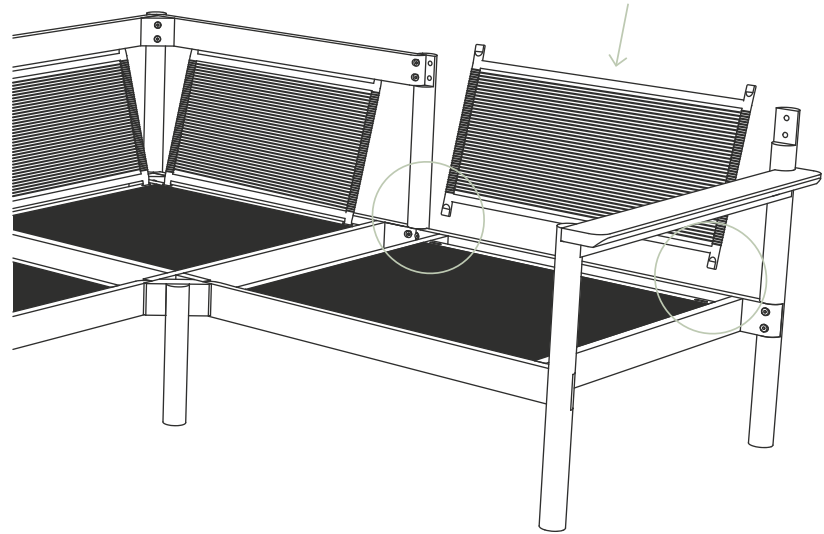
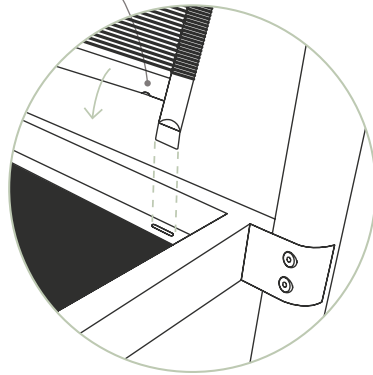

5

Secure roped back to base

Insert the Module Roped Back into the slots of the Module Base.

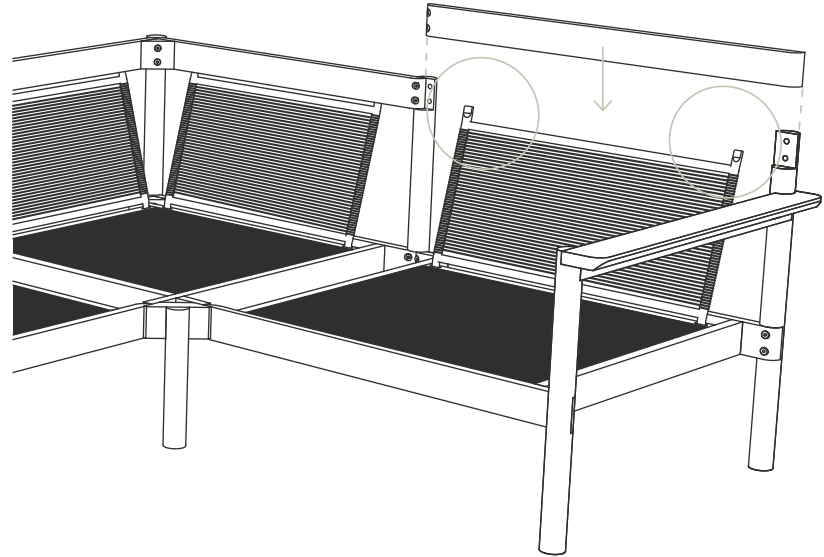
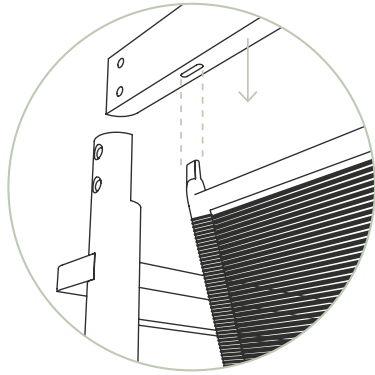

6

Attach back support to roped back

Lower the Module Back Support onto the Module Roped Back by fitting the tabs into their corresponding slots, then insert.

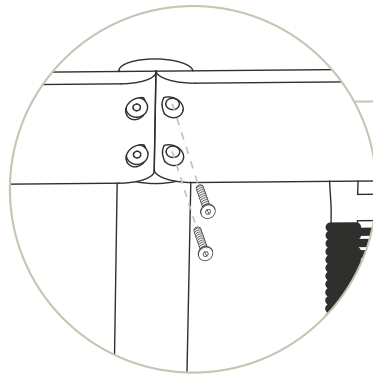

2X 30mm Hex Bolt

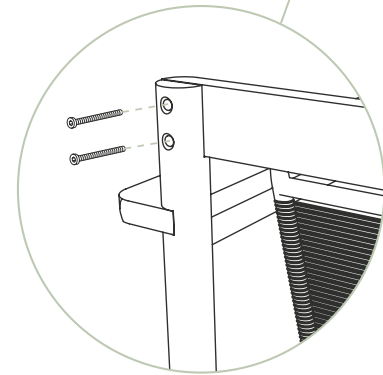
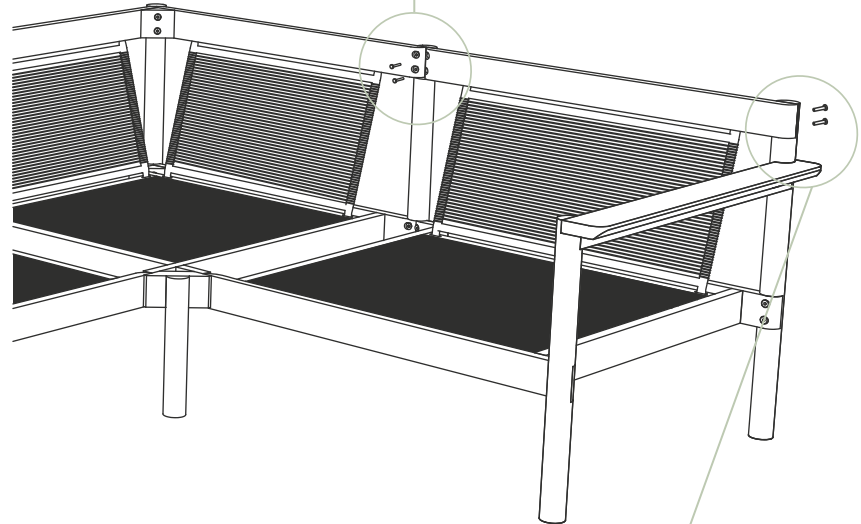

2X 40mm Hex Bolt

7

Fasten back support

Fasten the Module Back Support to the Long Leg with two 30mm Hex Bolts. Then, fasten to the Teak Arm with two 40mm Hex Bolts.

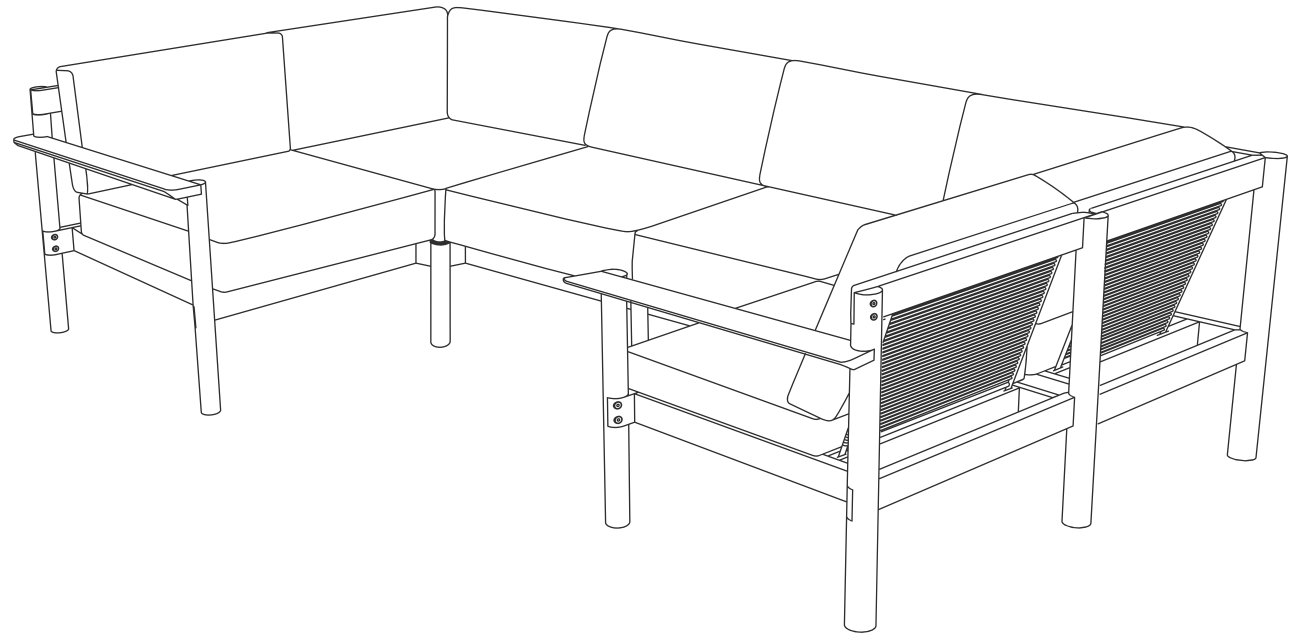

Add cushions

With the zipper seam facing backward, add base cushions. Finally, add the back cushions. Relax! You're ready to enjoy your sectional.

Contact

Have a question, comment, feedback?
We love hearing from customers.

support@hineighbor.com
hineighbor.com

neighbor