

PRODUCT SPECIFICATION

12.8" TFT LCD MODULE

MODEL:T128128720-A0WMN-001 Ver:1.3

ROHS

< ◇ > Preliminary Specification

< ◆ > Finally Specification

CUSTOMER'S APPROVAL	
CUSTOMER :	
SIGNATURE:	DATE:

APPROVED BY	PM REVIEWED	PD REVIEWED	PREPARED BY

Revision History

Revision	Date	Originator	Detail	Remarks
1.0	2015.06.18	CGP	Initial Release	
1.1	2016.01.04	ZFY	Modify Luminance Modify Optical Characteristics	P6
1.2	2016.06.16	ZFY	Modify Interface Modify DC Characteristics Modify Timing Characteristics Modify Power Sequence	P4 P5 P12 /P13 P14
1.3	2018.04.11	ZFY	Modify many details	P23/P24

Table of Contents

No.	Item	Page
1.	General Description.....	4
2.	Module Parameter.....	4
3.	Absolute Maximum Ratings.....	4
4.	DC Characteristics	5
5.	Backlight Characteristic.....	5
5.1.	Backlight Characteristic.....	5
5.2.	Backlighting circuit.....	5
6.	Optical Characteristics	6
6.1.	Definition of Response Time	6
6.2.	Definition of Contrast Ratio	7
6.3.	Definition of Viewing Angles	7
6.4.	Definition of Color Appearance.....	8
6.5.	Definition of Surface Luminance, Uniformity and Transmittance	8
7.	Block Diagram and Power Supply.....	9
8.	Interface Pins Definition	10
9.	Timing Characteristics	12
9.1.	LVDS signal timing specification	12
9.2.	Data Input Format.....	13
10.	Power Sequence	14
11.	Quality Assurance	15
11.1	Purpose	15
11.2	Standard for Quality Test	15
11.3	Nonconforming Analysis & Disposition.....	15
11.4	Agreement Items	15
11.5	Standard of the Product Visual Inspection	15
11.6	Inspection Specification for the TFT module	16
11.8	Classification of Defects.....	21
11.9	Identification/marketing criteria.....	21
11.10	Packaging.....	21
12.	Reliability Specification.....	22
13.	Precautions and Warranty.....	23
13.1.	Safety	23
13.2.	Handling	23
13.3.	Storage	23
13.4.	Metal Pin (Apply to Products with Metal Pins).....	23
13.5.	Operation.....	24
13.6.	Static Electricity	24
13.7.	Limited Warranty	24
14.	Packaging.....	25
15.	Outline Drawing.....	26

1. General Description

The specification is a transmissive type color active matrix liquid crystal display (LCD) which uses amorphous thin film transistor (TFT) as switching devices. This product is composed of a TFT-LCD panel, driver ICs, and a backlight unit.

2. Module Parameter

Features	Details	Unit
Display Size(Diagonal)	12.8"	
Display Mode	Transmissive/Normally Black	
Resolution	1280 RGB x 720	Pixels
View Direction	FULL VIEW	Best Image
Module Outline	300.8(H) x 179.5(V) x 5.7(T) (Note1)	mm
Active Area	283.2(H) x 159.3(V)	mm
Pixel Pitch	221.25(H) x 221.25(V)	um
Pixel Arrangement	RGB 2 domain Stripe	
Polarizer Surface Treatment	Anti-Glare	
Display Colors	16.7 M	
Interface	8bits LVDS Interface	
With or Without Touch Panel	Without	
Operating Temperature	-20~70	°C
Storage Temperature	-40~85	°C
Weight	TBD	g

Note 1: Exclusive hooks, posts, FFC/FPC tail etc.

3. Absolute Maximum Ratings

$V_{SS}=0V, T_a=25^{\circ}C$

Item	Symbol	Min.	Max.	Unit
Supply Voltage	VCC	-0.3	3.6	V
Storage temperature	T _{STG}	-40	+85	°C
Operating temperature	T _{OP}	-20	+70	°C

Note 1: If T_a below $50^{\circ}C$, the maximal humidity is 90%RH, if T_a over $50^{\circ}C$, absolute humidity should be less than 60%RH.

Note 2: The response time will be extremely slow when the operating temperature is around $-10^{\circ}C$, and the back ground will become darker at high temperature operating.

4. DC Characteristics

Item		Symbol	Min.	Typ.	Max.	Unit
Supply Voltage	Logic	VCC	3	3.3	3.6	V
	Analog	AVDD	11.3	11.5	11.7	V
Gate On Voltage		VGH	21	22	23	V
Gate Off Voltage		VGL	-9.6	-9	-8.4	V
Common Voltage		VCOM	3.85	4.05	4.25	V

Note 1: Typ. VCOM is only a reference value, it must be optimized according to each LCM. Be sure to use VR

5. Backlight Characteristic

5.1. Backlight Characteristic

Item	Symbol	Condition	Min.	Typ.	Max.	Unit
Forward Voltage	V _F	T _a =25 °C, I _F =50mA/LED	11.6	12.4	13.2	V
Forward Current	I _F	T _a =25 °C, V _F =3.1/LED	-	500	-	mA
Power dissipation	P _D		-	6200	-	mW
Uniformity	Avg		70	75	-	%
Drive method	Constant current					
LED Configuration	40 White LEDs (4 LEDs in string and 10 groups in parallel)					

5.2. Backlighting circuit

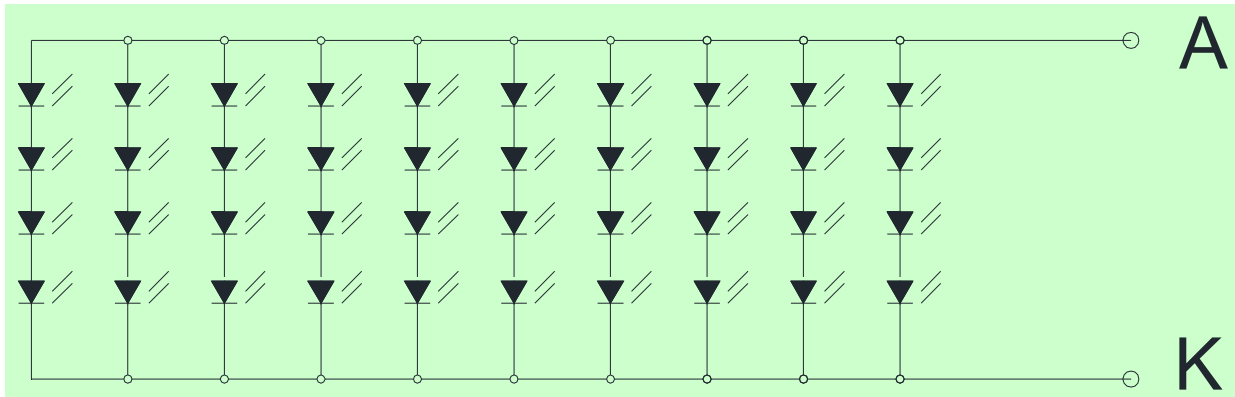

6. Optical Characteristics

Optical Characteristics Ta=25°C, VCC=3.3V, TN LC+ Polarizer

	Item	Symbol	Condition	Specification			Unit	
				Min.	Typ.	Max.		
Backlight On (Transmissive Mode)	Luminance on TFT($I_f=50\text{mA/LED}$)	Lv		400	500	-	cd/m ²	
	Contrast ratio(See 6.3)	CR		-	900	-		
	Response time (See 6.2)	T _{R+T_F}		-	30	35	ms	
	Chromaticity Transmissive (See 6.5)	Red	X _R	Center CR≥10	0.597	0.647	0.697	
			Y _R		0.291	0.341	0.391	
		Green	X _G		0.254	0.304	0.354	
			Y _G		0.602	0.652	0.702	
		Blue	X _B		0.091	0.141	0.191	
			Y _B		0.062	0.112	0.162	
	White	X _W	0.268	0.318	0.368			
Y _W		0.346	0.396	0.446				
Viewing Angle (See 6.4)	Horizontal	θ _{X+}	Center CR≥10	70	80	-	Deg.	
		θ _{X-}		70	80	-		
	Vertical	φ _{Y+}		70	80	-		
		φ _{Y-}		70	80	-		
NTSC ratio (Color gamut)				60	70	-	%	

6.1. Definition of Response Time

6.1.1. Normally Black Type (Negative)

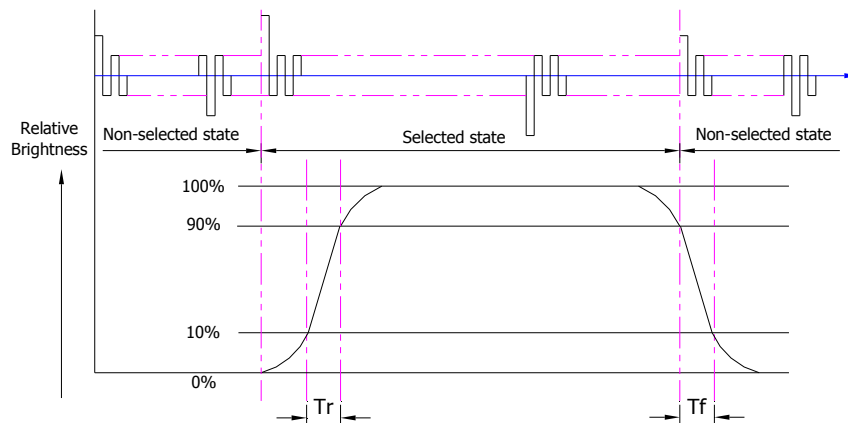

Tr is the time it takes to change from non-selected stage with relative luminance 10% to selected state with relative luminance 90%;

Tf is the time it takes to change from selected state with relative luminance 90% to non-selected state with relative luminance 10%.

Note: Measuring machine: LCD-5100

6.1.2. Normally White Type (Positive)

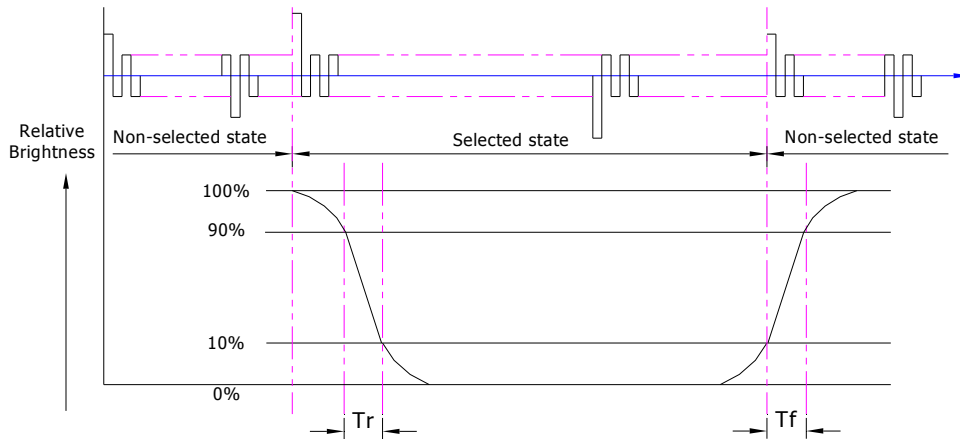

Tr is the time it takes to change from non-selected state with relative luminance 90% to selected state with relative luminance 10%;

Tf is the time it takes to change from selected state with relative luminance 10% to non-selected state with relative luminance 90%;

Note: Measuring machine: LCD-5100 or EQUI

6.2. Definition of Contrast Ratio

Contrast is measured perpendicular to display surface in reflective and transmissive mode.

The measurement condition is:

Measuring Equipment	Eldim or Equivalent
Measuring Point Diameter	3mm//1mm
Measuring Point Location	Active Area centre point
Test pattern	A: All Pixels white
	B: All Pixel black
Contrast setting	Maximum

Definitions: CR (Contrast) = Luminance of White Pixel / Luminance of Black Pixel

6.3. Definition of Viewing Angles

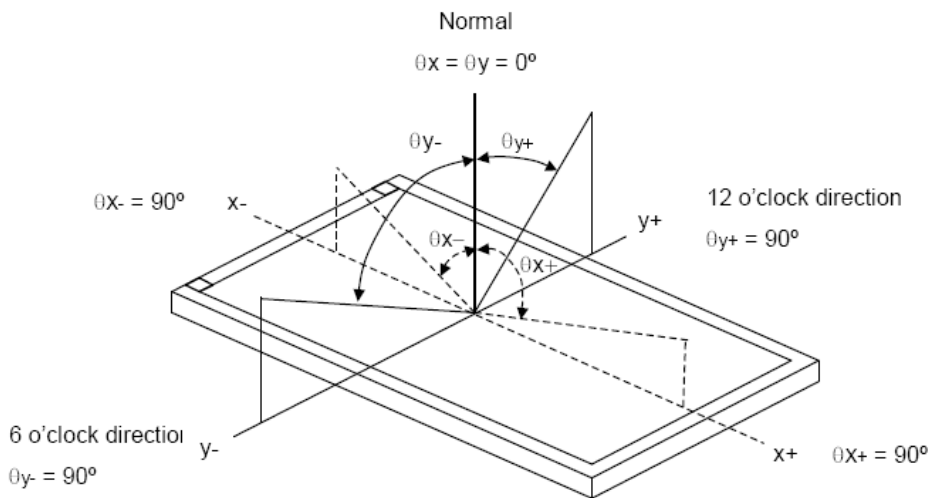

Measuring machine: LCD-5100 or EQUI

6.4. Definition of Color Appearance

R,G,B and W are defined by (x, y) on the IE chromaticity diagram

NTSC=area of RGB triangle/area of NTSC triangleX100%

Measuring picture: Red, Green, Blue and White (Measuring machine: BM-7)

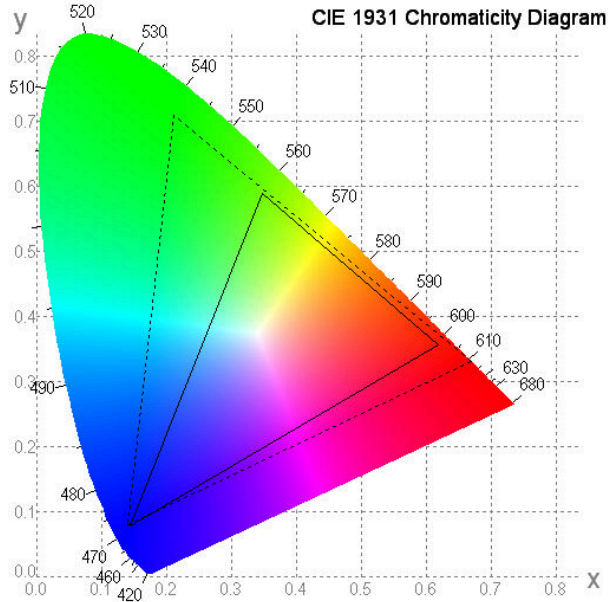

6.5. Definition of Surface Luminance, Uniformity and Transmittance

Using the transmissive mode measurement approach, measure the white screen luminance of the display panel and backlight.

- 6.5.1. Surface Luminance: $L_V = \text{average} (L_{P1}:L_{P9})$
- 6.5.2. Uniformity = Minimal ($L_{P1}:L_{P9}$) / Maximal ($L_{P1}:L_{P9}$) * 100%
- 6.5.3. Transmittance = L_V on LCD / L_V on Backlight * 100%

Note: Measuring machine: BM-7

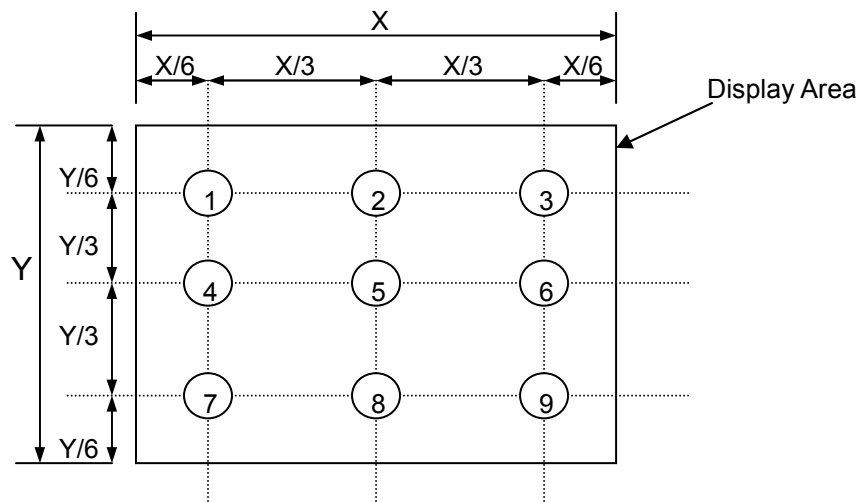

7. Block Diagram and Power Supply

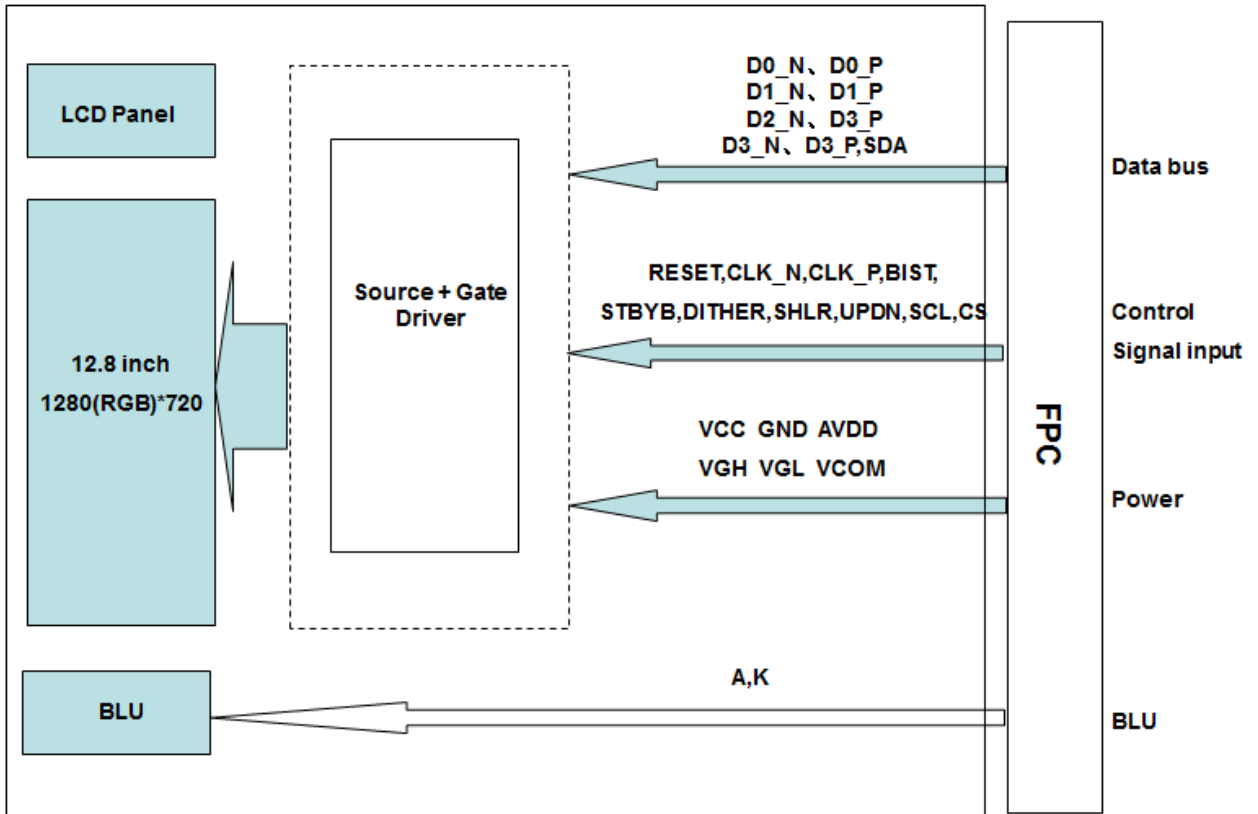

8. Interface Pins Definition

Connector Part Number : ACES: 50671-05041-001

No.	Symbol	Function	Remark
1	VCC	Power Voltage for digital circuit.	
2	VCC	Power Voltage for digital circuit.	
3	NC	No connection.	
4	GND	Ground.	
5	GND	Ground.	
6	VCOM	Common Voltage.	
7	VCOM	Common Voltage.	
8	UPDN	Gate driver Up/Down scan setting. Normally pull high. When UPDN =H, normal scan (Default); when UPDN=L, Reverse scan	
9	SHLR	Source Driver internal shift register is controlled by this pin as shown below: Normally pull high. SHLR=H: SO1->SO2->SO3 -> SO->1024(Default) SHLR=L: SO1024->SO1023->SO1022-> SO->1	
10	Reset	Global Reset, keep VDD during operation. Normally pull high. Suggest to connecting with an RC rest circuit for stability.	
11	STBYB	Standby mode, Normally pulled high. STBYB="1", normal operation. STBYB="0", timing controller, source driver will turn off, all output are High-Z.	
12	BIST	Normal Operation/BIST pattern select, normally pull low. When BIST =H, BIST(CLK input is not needed) When BIST = L, normal operation (default)	
13	GND	Ground.	
14	NC	No connection.	
15	VGL	Gate OFF Voltage.	
16	VGL	Gate OFF Voltage.	
17	VGH	Gate ON Voltage.	
18	VGH	Gate ON Voltage.	
19	AVDD	Power for Analog Circuit.	
20	AVDD	Power for Analog Circuit.	
21	NC	No connection.	
22	GND	Ground.	
23	GND	Ground.	
24	CLK_N	-LVDS differential clock input.	
25	CLK_P	+LVDS differential clock input.	
26	GND	Ground.	
27	D0_N	-LVDS differential data input.	
28	D0_P	+LVDS differential data input.	

29	GND	Ground.	
30	D1_N	-LVDS differential data input.	
31	D1_P	+LVDS differential data input.	
32	GND	Ground.	
33	D2_N	-LVDS differential data input.	
34	D2_P	+LVDS differential data input.	
35	GND	Ground.	
36	D3_N	-LVDS differential data input.	
37	D3_P	+LVDS differential data input.	
38	GND	Ground.	
39	GND	Ground.	
40	SCL	Serial Clock PIN	
41	SDA	Serial Data PIN	
42	CS	Chip Select PIN	
43	GND	Ground.	
44	DITHER	Dithering function enable control, normally pull low. When DITHER = H, Enable internal dithering function, When Dither = L, Disable internal dithering function.	
45	AVDD	Power for Analog Circuit.	
46	AVDD	Power for Analog Circuit.	
47	VCOM	Common Voltage.	
48	VCOM	Common Voltage.	
49	NC	No connection.	
50	NC	No connection.	

9. Timing Characteristics

9.1. LVDS signal timing specification

Parameter	Symbol	Min.	Typ.	Max.	Unit	Condition
Clock frequency	RxFCLK	60	65.5	71.3	MHz	
Horizontal Display Area	thd	1280			DCLK	
HS Period	th	1370	1440	1500	DCLK	
HS Blanking	Thb+thfp	90	160	220	DCLK	
Vertical Display Area	tvd	720			TH	
VS Period	tv	730	758	792	TH	
VS Blanking	Tvbp+tvfp	10	38	72	TH	
Input data skew margin	TRSKM	500	-	-	ps	VID =400mV RxVCM=1.2V RxFCLK=65.5MHz
Clock high time	TLVCH	-	$\frac{4}{(7 \cdot RxFCLK)}$		ns	
Clock low time	TLVCL		$\frac{3}{(7 \cdot RxFCLK)}$		ns	
PLL wake-up time	TenPLL			150	us	

9.2. Data Input Format

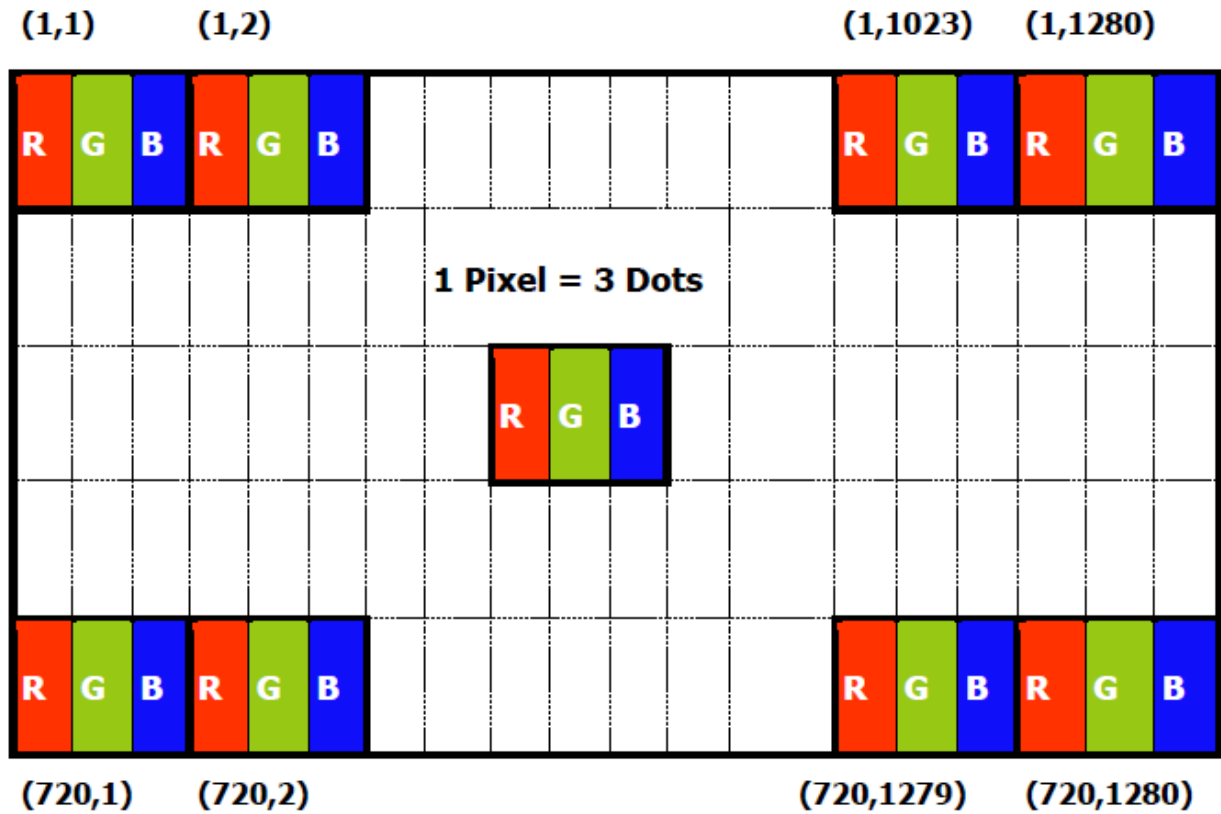

8-bit LVDS input, VESA MODE.

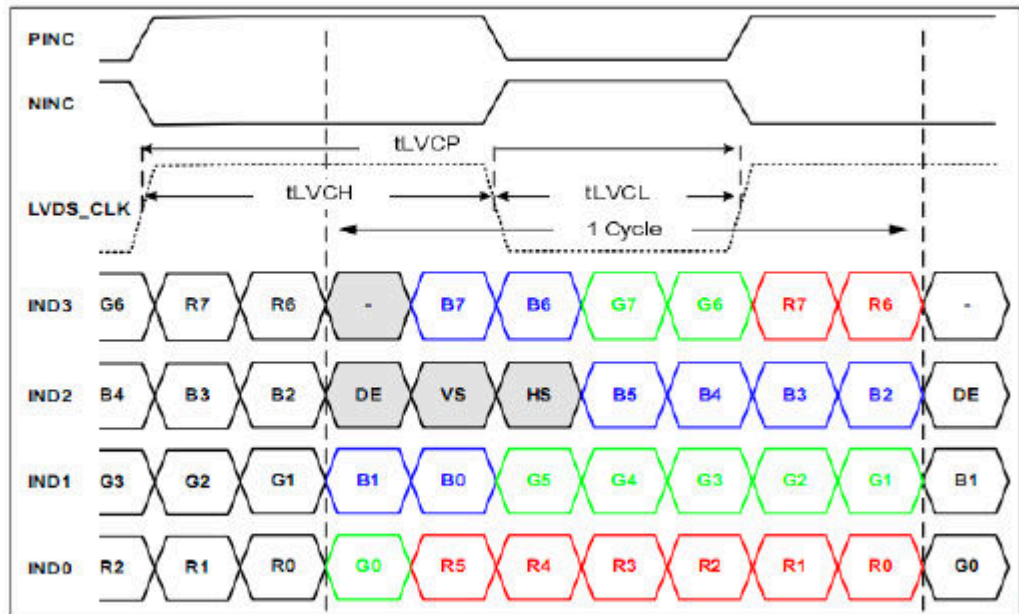

8-BIT LVDS Input Signal Format – VESA MODE

10. Power Sequence

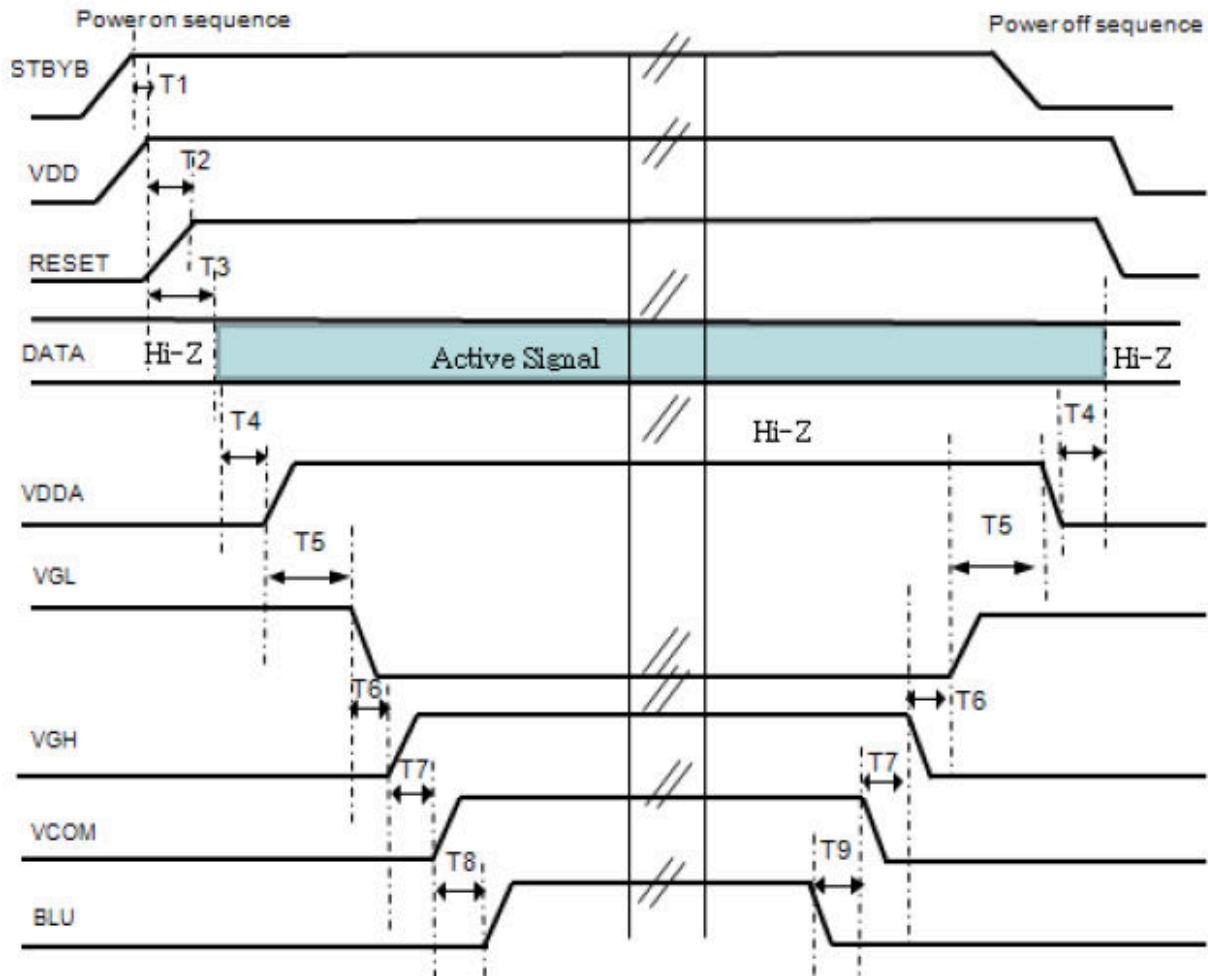

Parameter	Symbol	Timing			Unit	Notes
		Min	Typ.	Max		
Power On & Off sequence	T1	2	-	-	ms	
	T2	0.5	-	-		
	T3	20	-	-		
	T4	5	-	-		
	T5	5	-	-		
	T6	5	-	-		
	T7	5	-	-		
	T8	200	-	-		
	T9	500	-	-		

Notes:

1. When the power supply DVDD is 0V, keep the level of input signals on the low or keep high impedance.
2. Do not keep the interface signal high impedance when power is on.
Back Light must be turn on after power for logic and interface signal are valid.

11. Quality Assurance

11.1 Purpose

This standard for Quality Assurance assures the quality of LCD module products supplied to customer.

11.2 Standard for Quality Test

11.2.1 Sampling Plan:

GB2828.1-2012

Single sampling, general inspection level II.

11.2.2 Sampling Criteria:

Visual inspection: AQL 1.5%

Electrical functional: AQL 0.65%.

11.2.3 Reliability Test:

Detailed requirement refer to Reliability Test Specification.

11.3 Nonconforming Analysis & Disposition

11.3.1 Nonconforming analysis:

11.3.1.1 Customer should provide overall information of non-conforming sample for their complaints.

11.3.1.2 After receipt of detailed information from customer, the analysis of nonconforming parts usually should be finished in one week.

11.3.1.3 If cannot finish the analysis on time, customer will be notified with the progress status.

11.3.2 Disposition of nonconforming:

11.3.2.1 Non-conforming product over PPM level will be replaced.

11.3.2.2 The cause of non-conformance will be analyzed. Corrective action will be discussed and implemented.

11.4 Agreement Items

Shall negotiate with customer if the following situation occurs:

11.4.1 There is any discrepancy in standard of quality assurance.

11.4.2 Additional requirement to be added in product specification.

11.4.3 Any other special problem.

11.5 Standard of the Product Visual Inspection

11.5.1 Appearance inspection:

11.5.1.1 The inspection must be under illumination about 1000 – 1500 lx, and the distance of view must be at 30cm ± 2cm.

11.5.1.2 The viewing angle should be 45° from the vertical line without reflection light or follows customer's viewing angle specifications.

11.5.1.3 Definition of area: A Zone: Active Area, B Zone: Viewing Area,

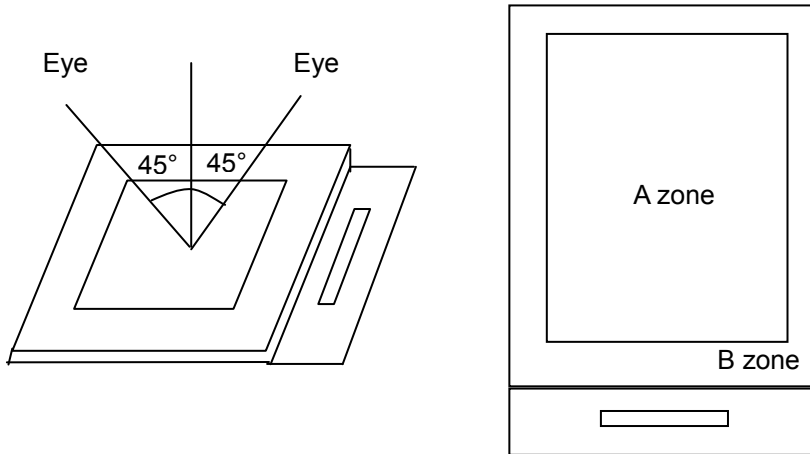

11.5.2 Basic principle:

11.5.2.1 A set of sample to indicate the limit of acceptable quality level must be discussed by both us and customer when there is any dispute happened.

11.5.2.2 New item must be added on time when it is necessary.

11.6 Inspection Specification for the TFT module

No.	Item	Criteria (Unit: mm)																			
01	Black / White spot Foreign material (Round type) Pinholes Stain Particles inside cell. (Minor defect)	<p>$\phi = (a + b) / 2$</p> <p>Distance between 2 defects should more than 5mm apart.</p>	<table border="1"> <thead> <tr> <th>Size</th> <th>Area</th> <th>Acc. Qty</th> </tr> </thead> <tbody> <tr> <td>$\phi \leq 0.20$</td> <td></td> <td>Ignore</td> </tr> <tr> <td>$0.20 < \phi \leq 0.50$</td> <td></td> <td>$N \leq 3$</td> </tr> <tr> <td>$0.50 < \phi$</td> <td></td> <td>0</td> </tr> </tbody> </table>	Size	Area	Acc. Qty	$\phi \leq 0.20$		Ignore	$0.20 < \phi \leq 0.50$		$N \leq 3$	$0.50 < \phi$		0						
Size	Area	Acc. Qty																			
$\phi \leq 0.20$		Ignore																			
$0.20 < \phi \leq 0.50$		$N \leq 3$																			
$0.50 < \phi$		0																			
02	Electrical Defect (Minor defect)	<table border="1"> <thead> <tr> <th>Bright dot</th> <th>Display Area</th> <th>Total</th> <th rowspan="3">Note1</th> </tr> </thead> <tbody> <tr> <td></td> <td>$N \leq 2$</td> <td>$N \leq 2$</td> </tr> <tr> <td>Dark dot</td> <td>$N \leq 4$</td> <td>$N \leq 4$</td> </tr> <tr> <td>T tal dot</td> <td>$N \leq 4$</td> <td>$N \leq 4$</td> <td></td> </tr> <tr> <td>Mura</td> <td colspan="2">Not visible through 5% ND filters.</td> <td>Note 2</td> </tr> </tbody> </table> <p>Remark: 1. Bright dot caused by scratch and foreign object accords to item 1.</p>	Bright dot	Display Area	Total	Note1		$N \leq 2$	$N \leq 2$	Dark dot	$N \leq 4$	$N \leq 4$	T tal dot	$N \leq 4$	$N \leq 4$		Mura	Not visible through 5% ND filters.		Note 2	
Bright dot	Display Area	Total	Note1																		
	$N \leq 2$	$N \leq 2$																			
Dark dot	$N \leq 4$	$N \leq 4$																			
T tal dot	$N \leq 4$	$N \leq 4$																			
Mura	Not visible through 5% ND filters.		Note 2																		

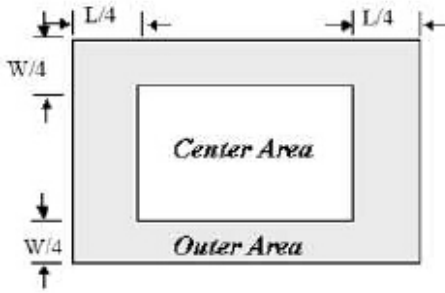
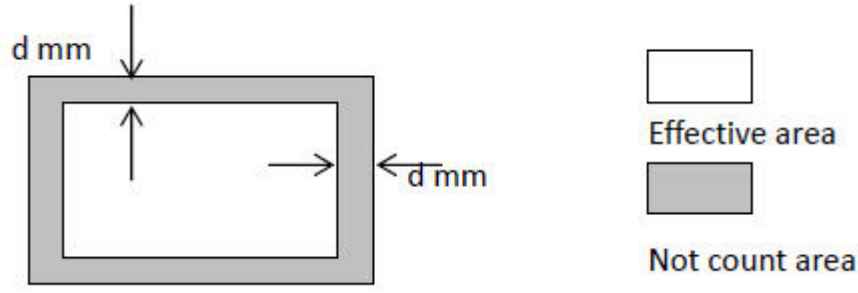
03	Inactive Area (Minor defect)	<p>Line Criteria: $L \leq 1\text{mm}$, $W \leq 0.1\text{mm}$, Dot Criteria: Please refer to Note 1,2&3 Note1: Definition of Area</p>  <p>Note2:</p> <table border="1" data-bbox="462 728 1388 1108"> <thead> <tr> <th>尺寸</th> <th>缺陷</th> <th>中心 Center</th> <th>外圍 Outer</th> <th>總數 Total</th> <th>備註</th> </tr> </thead> <tbody> <tr> <td>All</td> <td>$\varnothing < 0.2\text{mm}$;</td> <td colspan="4" style="text-align: center;">不計數</td> </tr> <tr> <td><6"</td> <td>$0.2 \leq \varnothing \leq 0.3\text{mm}$; $L \leq 1\text{mm}, W \leq 0.1\text{mm}$</td> <td>$N \leq 1$</td> <td>$N \leq 2$</td> <td>$N \leq 3$</td> <td></td> </tr> <tr> <td>6~8"</td> <td>$0.2 \leq \varnothing \leq 0.5\text{mm}$; $L \leq 1\text{mm}, W \leq 0.1\text{mm}$</td> <td>$N \leq 2$</td> <td>$N \leq 3$</td> <td>$N \leq 5$</td> <td>$0.4 \leq \varnothing \leq 0.5\text{mm}, N \leq 1$ is allowed at outer.)</td> </tr> <tr> <td>8.1"~10.1"</td> <td>$0.2 \leq \varnothing \leq 0.5\text{mm}$; $L \leq 1\text{mm}, W \leq 0.1\text{mm}$</td> <td>$N \leq 2$</td> <td>$N \leq 5$</td> <td>$N \leq 7$</td> <td>$0.4 \leq \varnothing \leq 0.5\text{mm}, N \leq 2$ is allowed at outer.)</td> </tr> <tr> <td>10.2"~15"</td> <td>$0.2 \leq \varnothing \leq 0.5\text{mm}$; $L \leq 1\text{mm}, W \leq 0.1\text{mm}$</td> <td>$N \leq 5$</td> <td>$N \leq 10$</td> <td>$N \leq 15$</td> <td>$(0.4 \leq \varnothing \leq 0.5\text{mm}, N \leq 5$ is allowed at outer.)</td> </tr> </tbody> </table> <p>Note3: Inactive area $D < 0.2\text{mm}$ is not counted without appearance observation. Remark: Effective area is from the POL cutting side to 0.5mm of inside. This is no count area. Other part is effective area. In no count area, any defect can ignore. In effective area, have to judge from above-mentioned specification.</p> 	尺寸	缺陷	中心 Center	外圍 Outer	總數 Total	備註	All	$\varnothing < 0.2\text{mm}$;	不計數				<6"	$0.2 \leq \varnothing \leq 0.3\text{mm}$; $L \leq 1\text{mm}, W \leq 0.1\text{mm}$	$N \leq 1$	$N \leq 2$	$N \leq 3$		6~8"	$0.2 \leq \varnothing \leq 0.5\text{mm}$; $L \leq 1\text{mm}, W \leq 0.1\text{mm}$	$N \leq 2$	$N \leq 3$	$N \leq 5$	$0.4 \leq \varnothing \leq 0.5\text{mm}, N \leq 1$ is allowed at outer.)	8.1"~10.1"	$0.2 \leq \varnothing \leq 0.5\text{mm}$; $L \leq 1\text{mm}, W \leq 0.1\text{mm}$	$N \leq 2$	$N \leq 5$	$N \leq 7$	$0.4 \leq \varnothing \leq 0.5\text{mm}, N \leq 2$ is allowed at outer.)	10.2"~15"	$0.2 \leq \varnothing \leq 0.5\text{mm}$; $L \leq 1\text{mm}, W \leq 0.1\text{mm}$	$N \leq 5$	$N \leq 10$	$N \leq 15$	$(0.4 \leq \varnothing \leq 0.5\text{mm}, N \leq 5$ is allowed at outer.)
		尺寸	缺陷	中心 Center	外圍 Outer	總數 Total	備註																															
All	$\varnothing < 0.2\text{mm}$;	不計數																																				
<6"	$0.2 \leq \varnothing \leq 0.3\text{mm}$; $L \leq 1\text{mm}, W \leq 0.1\text{mm}$	$N \leq 1$	$N \leq 2$	$N \leq 3$																																		
6~8"	$0.2 \leq \varnothing \leq 0.5\text{mm}$; $L \leq 1\text{mm}, W \leq 0.1\text{mm}$	$N \leq 2$	$N \leq 3$	$N \leq 5$	$0.4 \leq \varnothing \leq 0.5\text{mm}, N \leq 1$ is allowed at outer.)																																	
8.1"~10.1"	$0.2 \leq \varnothing \leq 0.5\text{mm}$; $L \leq 1\text{mm}, W \leq 0.1\text{mm}$	$N \leq 2$	$N \leq 5$	$N \leq 7$	$0.4 \leq \varnothing \leq 0.5\text{mm}, N \leq 2$ is allowed at outer.)																																	
10.2"~15"	$0.2 \leq \varnothing \leq 0.5\text{mm}$; $L \leq 1\text{mm}, W \leq 0.1\text{mm}$	$N \leq 5$	$N \leq 10$	$N \leq 15$	$(0.4 \leq \varnothing \leq 0.5\text{mm}, N \leq 5$ is allowed at outer.)																																	

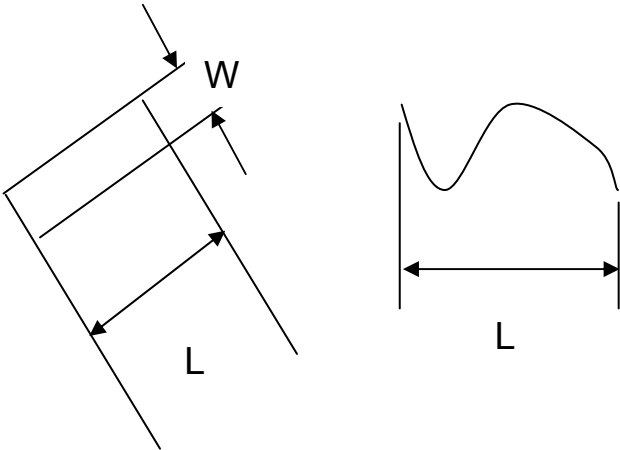
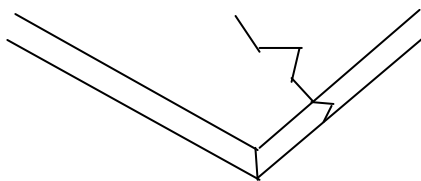
<p>04</p>	<p>Black and White line Scratch Foreign material (Line type) (Minor defect)</p>	 <table border="1" data-bbox="518 705 1141 974"> <thead> <tr> <th>Length</th> <th>Width</th> <th>Acc. Qt</th> </tr> </thead> <tbody> <tr> <td>/</td> <td>$W \leq 0.1$</td> <td>Ignore</td> </tr> <tr> <td>$L \leq 2.5$</td> <td>$0.1 < W \leq 0.2$</td> <td>3</td> </tr> <tr> <td>$L > 2.5$</td> <td>$0.2 < W$</td> <td>0</td> </tr> <tr> <td colspan="2">Total</td> <td>3</td> </tr> </tbody> </table> <p>Distance between 2 defects should more than 3mm apart. Scratches not viewable through the back of the display are acceptable.</p>	Length	Width	Acc. Qt	/	$W \leq 0.1$	Ignore	$L \leq 2.5$	$0.1 < W \leq 0.2$	3	$L > 2.5$	$0.2 < W$	0	Total		3
Length	Width	Acc. Qt															
/	$W \leq 0.1$	Ignore															
$L \leq 2.5$	$0.1 < W \leq 0.2$	3															
$L > 2.5$	$0.2 < W$	0															
Total		3															
<p>05</p>	<p>Glass Crack (Minor defect)</p>	 <p>Crack is potential to enlarge, any type is not allowed.</p>															

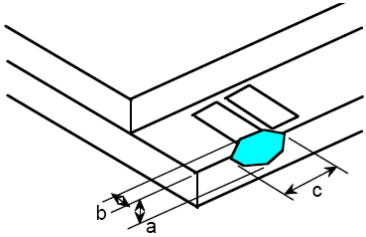
<p>06</p>	<p>Glass Chipping Pad Area: (Minor defect)</p> 	<table border="1" data-bbox="861 1657 1332 1836"> <thead> <tr> <th>Length and Width</th> <th>Acc. Qty</th> </tr> </thead> <tbody> <tr> <td>$c > 3.0, b < 1.0$</td> <td>1</td> </tr> <tr> <td>$c < 3.0, b < 1.0$</td> <td>3</td> </tr> <tr> <td colspan="2">$a < \text{Glass Thickness}$</td> </tr> </tbody> </table>	Length and Width	Acc. Qty	$c > 3.0, b < 1.0$	1	$c < 3.0, b < 1.0$	3	$a < \text{Glass Thickness}$	
Length and Width	Acc. Qty									
$c > 3.0, b < 1.0$	1									
$c < 3.0, b < 1.0$	3									
$a < \text{Glass Thickness}$										

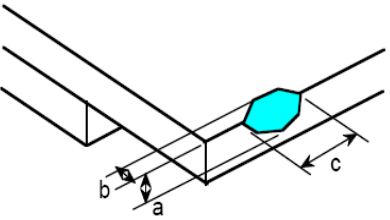
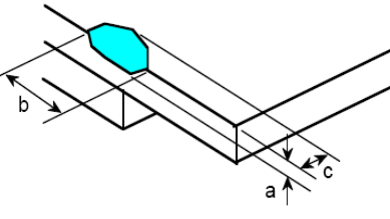
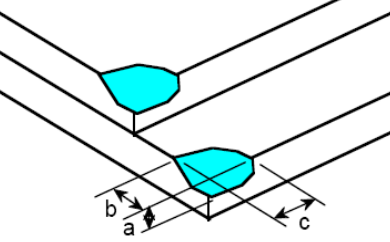
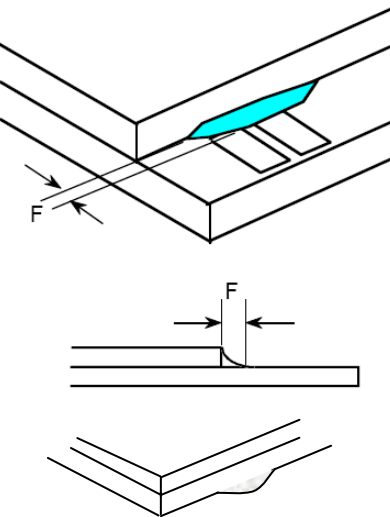
<p>07</p>	<p>Glass Chipping Rear of Pad Area: (Minor defect)</p> 	<table border="1"> <thead> <tr> <th>Length and Width</th> <th>Acc. Qty</th> </tr> </thead> <tbody> <tr> <td>$c > 3.0, b < 1.0$</td> <td>1</td> </tr> <tr> <td>$c < 3.0, b < 1.0$</td> <td>2</td> </tr> <tr> <td>$c < 3.0, b < 0.5$</td> <td>4</td> </tr> <tr> <td colspan="2">$a < \text{Glass Thickness}$</td> </tr> </tbody> </table>	Length and Width	Acc. Qty	$c > 3.0, b < 1.0$	1	$c < 3.0, b < 1.0$	2	$c < 3.0, b < 0.5$	4	$a < \text{Glass Thickness}$	
Length and Width	Acc. Qty											
$c > 3.0, b < 1.0$	1											
$c < 3.0, b < 1.0$	2											
$c < 3.0, b < 0.5$	4											
$a < \text{Glass Thickness}$												
<p>08</p>	<p>Glass Chipping Except Pad Area: (Minor defect)</p> 	<table border="1"> <thead> <tr> <th>Length and Width</th> <th>Acc. Qty</th> </tr> </thead> <tbody> <tr> <td>$c > 3.0, b < 1.0$</td> <td>1</td> </tr> <tr> <td>$c < 3.0, b < 1.0$</td> <td>2</td> </tr> <tr> <td>$c < 3.0, b < 0.5$</td> <td>4</td> </tr> <tr> <td colspan="2">$a < \text{Glass Thickness}$</td> </tr> </tbody> </table>	Length and Width	Acc. Qty	$c > 3.0, b < 1.0$	1	$c < 3.0, b < 1.0$	2	$c < 3.0, b < 0.5$	4	$a < \text{Glass Thickness}$	
Length and Width	Acc. Qty											
$c > 3.0, b < 1.0$	1											
$c < 3.0, b < 1.0$	2											
$c < 3.0, b < 0.5$	4											
$a < \text{Glass Thickness}$												
<p>09</p>	<p>Glass Corner Chipping: (Minor defect)</p> 	<table border="1"> <thead> <tr> <th>Length and Width</th> <th>Acc. Qty</th> </tr> </thead> <tbody> <tr> <td>$c < 3.0, b < 3.0$</td> <td>Ignore</td> </tr> <tr> <td colspan="2">$a < \text{Glass Thickness}$</td> </tr> </tbody> </table>	Length and Width	Acc. Qty	$c < 3.0, b < 3.0$	Ignore	$a < \text{Glass Thickness}$					
Length and Width	Acc. Qty											
$c < 3.0, b < 3.0$	Ignore											
$a < \text{Glass Thickness}$												
<p>10</p>	<p>Glass Burr: (Minor defect)</p> 	<table border="1"> <thead> <tr> <th>Length</th> <th>Acc. Qty</th> </tr> </thead> <tbody> <tr> <td>$F < 1.0$</td> <td>Ignore</td> </tr> </tbody> </table> <p>Glass burr don't affect assemble and module dimension.</p>	Length	Acc. Qty	$F < 1.0$	Ignore						
Length	Acc. Qty											
$F < 1.0$	Ignore											

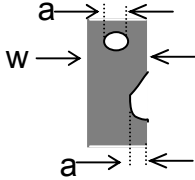
11	<p>FPC Defect: (Minor defect)</p> 	<p>10.1 Dent, pinhole width $a < w/3$. (w: circuitry width.)</p> <p>10.2 Open circuit is unacceptable.</p> <p>10.3 No oxidation, contamination and distortion.</p>								
12	Bubble on Polarizer (Minor defect)	<table border="1" data-bbox="737 660 1206 833"> <thead> <tr> <th>Diameter</th> <th>Acc. Qty</th> </tr> </thead> <tbody> <tr> <td>$\varphi \leq 0.30$</td> <td>Ignore</td> </tr> <tr> <td>$0.30 < \varphi \leq 0.50$</td> <td>$N \leq 2$</td> </tr> <tr> <td>$0.50 < \varphi$</td> <td>$N=0$</td> </tr> </tbody> </table>	Diameter	Acc. Qty	$\varphi \leq 0.30$	Ignore	$0.30 < \varphi \leq 0.50$	$N \leq 2$	$0.50 < \varphi$	$N=0$
Diameter	Acc. Qty									
$\varphi \leq 0.30$	Ignore									
$0.30 < \varphi \leq 0.50$	$N \leq 2$									
$0.50 < \varphi$	$N=0$									
13	Dent on Polarizer (Minor defect)	<table border="1" data-bbox="737 902 1206 1075"> <thead> <tr> <th>Diameter</th> <th>Acc. Qty</th> </tr> </thead> <tbody> <tr> <td>$\varphi \leq 0.25$</td> <td>Ignore</td> </tr> <tr> <td>$0.25 < \varphi \leq 0.50$</td> <td>$N \leq 4$</td> </tr> <tr> <td>$0.50 < \varphi$</td> <td>None</td> </tr> </tbody> </table>	Diameter	Acc. Qty	$\varphi \leq 0.25$	Ignore	$0.25 < \varphi \leq 0.50$	$N \leq 4$	$0.50 < \varphi$	None
Diameter	Acc. Qty									
$\varphi \leq 0.25$	Ignore									
$0.25 < \varphi \leq 0.50$	$N \leq 4$									
$0.50 < \varphi$	None									
14	Bezel	<p>13.1 No rust, distortion on the Bezel.</p> <p>13.2 No visible fingerprints, stains or other contamination.</p>								
15	Touch Panel	<p>D: Diameter W: width L: length</p> <p>14.1 Spot: $D < 0.25$ is acceptable $0.25 \leq D \leq 0.4$</p> <p>2dots are acceptable and the distance between defects should more than 10 mm.</p> <p>$D > 0.4$ is unacceptable</p> <p>14.2 Dent: $D > 0.40$ is unacceptable</p> <p>14.3 Scratch: $W \leq 0.03$, $L \leq 10$ is acceptable, $0.03 < W \leq 0.10$, $L \leq 10$ is acceptable</p> <p>Distance between 2 defects should more than 10 mm.</p> <p>$W > 0.10$ is unacceptable.</p>								
16	PCB	<p>15.1 No distortion or contamination on PCB terminals.</p> <p>15.2 All components on PCB must same as documented on the BOM/component layout.</p> <p>15.3 Follow IPC-A-600F.</p>								

17	Soldering	Follow IPC-A-610C standard
18	Electrical Defect (Major defect)	The below defects must be rejected. 17.1 Missing vertical / horizontal segment, 17.2 Abnormal Display. 17.3 No function or no display. 17.4 Current exceeds product specifications. 17.5 LCD viewing angle defect. 17.6 No Backlight. 17.7 Dark Backlight. 17.8 Touch Panel no function.

Remark: LCD Panel Broken shall be rejected. Defect out of LCD viewing area is acceptable.

11.8 Classification of Defects

11.8.1 Visual defects (Except no / wrong label) are treated as minor defect and electrical defect is major.

11.8.2 Two minor defects are equal to one major in lot sampling inspection.

11.9 Identification/marketing criteria

Any unit with illegible / wrong /double or no marking/ label shall be rejected.

11.10 Packaging

11.10.1 There should be no damage of the outside carton box, each packaging box should have one identical label.

11.10.2 Modules inside package box should have compliant mark.

11.10.3 All direct package materials shall offer ESD protection

Note1: Bright dot is defined as the defective area of the dot is larger than 50% of one sub-pixel area.

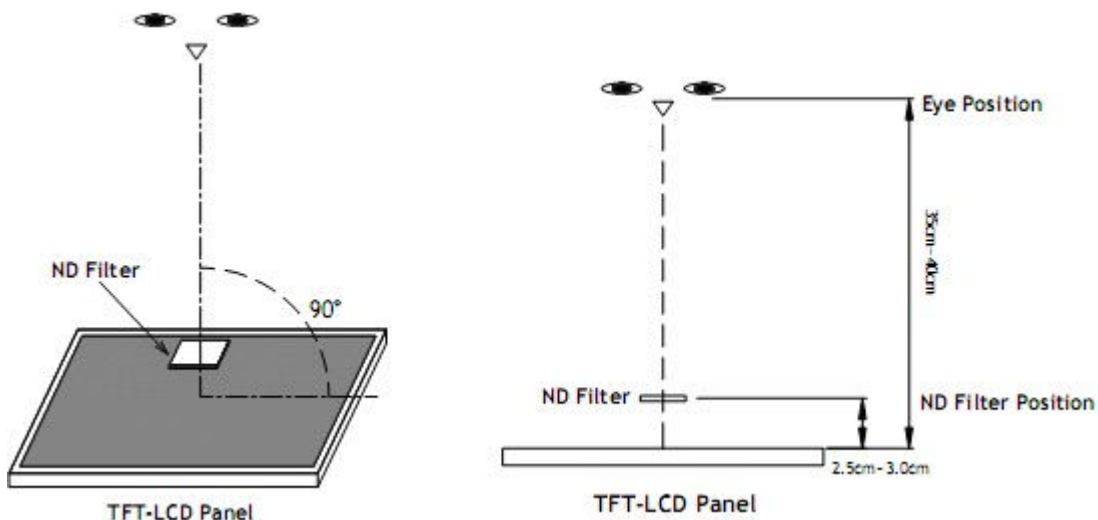

Bright dot: The bright dot size defect at black display pattern. It can be recognized by 2% transparency of filter when the distance between eyes and panel is $350\text{mm} \pm 50\text{mm}$.

Dark dot: Cyan, Magenta or Yellow dot size defect at white display pattern. It can be recognized by 5% transparency of filter when the distance between eyes and panel is $350\text{mm} \pm 50\text{mm}$.

Note2: Mura on display which appears darker / brighter against background brightness on parts of display area.

12. Reliability Specification

No	Item	Condition	Quantity	Criteria
1	High Temperature Operating	70°C, 96Hrs	2	GB/T2423.2-2008
2	Low Temperature Operating	-20°C, 96Hrs	2	GB/T2423.1-2008
3	High Humidity	50°C, 90%RH, 96Hrs	2	GB/T2423.3-2006
4	High Temperature Storage	85°C, 96Hrs	2	GB/T2423.2-2008
5	Low Temperature Storage	-40°C, 96Hrs	2	GB/T2423.1-2008
6	Thermal Cycling Test	-20°C, 60min~70°C, 60min, 20 cycles.	2	GB/T2423.22-2012
7	Packing vibration	Frequency range:10Hz~50Hz Acceleration of gravity:5G X, Y, Z 30 min for each direction.	2	GB/T5170.14-2009
8	Electrical Static Discharge	Air: ± 8KV 150pF/330 Ω 5 times	2	GB/T17626.2-2006
		Contact: ± 4KV 150pF/330 Ω 5 times		
9	Drop Test (Packaged)	Height:80 cm,1 corner, 3 edges, 6 surfaces.	2	GB/T2423.8-1995

Note1. No deflection cosmetic and operational function allowable.

Note2. Total current Consumption should be below double of initial value

13. Precautions and Warranty

13.1.Safety

13.1.1 The liquid crystal in the LCD is poisonous. Do not put it in your mouth. If the liquid crystal touches your skin or clothes, wash it off immediately using soap and water.

13.1.2 Since the liquid crystal cells are made of glass, do not apply strong impact on them. Handle with care.

13.2.Handling

13.2.1 Reverse and use within ratings in order to keep performance and prevent damage.

13.2.2 Do not wipe the polarizer with dry cloth, as it might cause scratch. If the surface of the LCD needs to be cleaned, wipe it swiftly with cotton or other soft cloth soaked with petroleum IPA, do not use other chemicals.

13.3.Storage

13.3.1. Do not store the LCD module beyond the specified temperature ranges.

13.3.2. Strong light exposure causes degradation of polarizer and color filter

13.4.Metal Pin (Apply to Products with Metal Pins)

13.4.1 Pins of LCD and Backlight

13.4.1.1 Solder tip can touch and press on the tip of Pin LEAD during the soldering

13.4.1.2 Recommended Soldering Conditions

Solder Type: Sn96.3~94-Ag3.3~4.3-Cu0.4~1.1

Maximum Solder Temperature: 370℃

Maximum Solder Time: 3s at the maximum temperature

Recommended Soldering Temp: 350±20℃

Typical Soldering Time: ≤3s

13.4.1.3 Solder Wetting

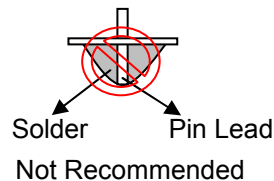
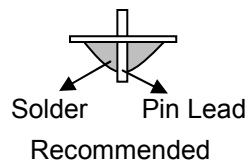

13.4.2 Pins of EL

13.4.2.1 Solder tip can touch and press on the tip of EL leads during soldering.

13.4.2.2 No Solder Paste on the soldering pad on the motherboard is recommended.

13.4.2.3 Recommended Soldering Conditions

Solder type: Nippon Alimit Leadfree SR-34, size 0.5mm

Recommended Solder Temperature: 270~290℃

Typical Soldering Time: ≤2s

Minimum solder distance from EL lamp (body):2.0mm

13.4.2.4 No horizontal press on the EL leads during soldering.

13.4.2.5 180° bend EL leads three times is not allowed.

13.4.2.6 Solder Wetting

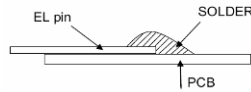

Recommended

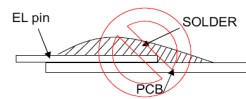

Not Recommended

13.4.2.7 The type of the solder iron:

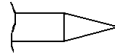

Recommended

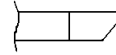

Not Recommended

13.4.2.8 Solder Pad

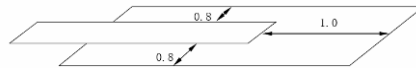

13.5.Operation

- 13.5.1. Do not drive LCD with DC voltage
- 13.5.2. Response time will increase below lower temperature
- 13.5.3. Display may change color with different temperature
- 13.5.4. Mechanical disturbance during operation, such as pressing on the display area, may cause the segments to appear “fractured”.
- 13.5.5. Do not connect or disconnect the LCM to or from the system when power is on.
- 13.5.6. Never use the LCM under abnormal condition of high temperature and high humidity.
- 13.5.7. Module has high frequency circuits. Sufficient suppression to the electromagnetic interface shall be done by system manufacturers. Grounding and shielding methods may be important to minimize the interference.
- 13.5.8. Do not display the fixed pattern for long time (we suggest the time not longer than one hour) because it may develop image sticking due to the TFT structure.

13.6.Static Electricity

- 13.6.1. CMOS LSIs are equipped in this unit, so care must be taken to avoid the electro-static charge, by ground human body, etc.
- 13.6.2. The normal static prevention measures should be observed for work clothes and benches.
- 13.6.3. The module should be kept into anti-static bags or other containers resistant to static for storage.

13.7.Limited Warranty

- 13.7.1 Our warranty liability is limited to repair and/or replacement. We will not be responsible for any consequential loss.
- 13.7.2 If possible, we suggest customer to use up all modules in six months. If the module storage time over twelve months, we suggest that recheck it before the module be used.
- 13.7.3 After the product shipped, any product quality issues must be feedback within three months, otherwise, we will not be responsible for the subsequent or consequential events.

14. Packaging

TBD

15. Outline Drawing

