

PRODUCT SPECIFICATION

8.0" TFT LCD MODULE

MODEL: T080102768-A3WMN-003 Ver:1.3

ROHS

< ◇ > Preliminary Specification

< ◆ > Finally Specification

| CUSTOMER'S APPROVAL | |
|---------------------|-------|
| CUSTOMER : | |
| SIGNATURE: | DATE: |
| | |

| APPROVED BY | PM REVIEWED | PD REVIEWED | PREPARED BY |
|----------------|----------------|----------------|----------------|
| | | | |

Revision History

| Revision | Date | Originator | Detail | Remarks |
|----------|------------|------------|---|---------------------------|
| 1.0 | 2016.06.24 | LJ | Initial Release | |
| 1.1 | 2016.12.10 | ZFY | Add weight Modify temperature Add Chromaticity Modify outline drawing(C) | P4 P4/P22 P6 P26 |
| 1.2 | 2016.12.13 | ZFY | Modify Uniformity | P5 |
| 1.3 | 2018.04.24 | ZFY | Modify many details | P23/P24 |
| | | | | |
| | | | | |
| | | | | |
| | | | | |
| | | | | |
| | | | | |

Table of Contents

| No. | Item | Page |
|-------|---|------|
| 1. | General Description..... | 4 |
| 2. | Module Parameter..... | 4 |
| 3. | Absolute Maximum Ratings..... | 4 |
| 4. | DC Characteristics | 5 |
| 5. | Backlight Characteristic..... | 5 |
| 5.1. | Backlight Characteristic..... | 5 |
| 5.2. | Backlighting circuit..... | 5 |
| 6. | Optical Characteristics | 6 |
| 6.1. | Optical Characteristics | 6 |
| 6.2. | Definition of Response Time | 6 |
| 6.3. | Definition of Contrast Ratio | 7 |
| 6.4. | Definition of Viewing Angles | 7 |
| 6.5. | Definition of Color Appearance..... | 7 |
| 6.6. | Definition of Surface Luminance, Uniformity and Transmittance | 8 |
| 7. | Block Diagram and Power Supply..... | 9 |
| 8. | Interface Pins Definition | 10 |
| 9. | Power Sequence | 12 |
| 10. | Timing Characteristics..... | 13 |
| 11. | Quality Assurance | 16 |
| 11.1 | Purpose | 16 |
| 11.2 | Standard for Quality Test | 16 |
| 11.3 | Nonconforming Analysis & Disposition..... | 16 |
| 11.4 | Agreement Items | 16 |
| 11.5 | Standard of the Product Visual Inspection | 16 |
| 11.6 | Inspection Specification..... | 17 |
| 11.7 | Classification of Defects | 21 |
| 11.8 | Identification/marketing criteria..... | 21 |
| 11.9 | Packing..... | 21 |
| 12. | Reliability Specification..... | 22 |
| 13. | Precautions and Warranty | 23 |
| 13.1. | Safety | 23 |
| 13.2. | Handling | 23 |
| 13.3. | Storage | 23 |
| 13.4. | Metal Pin (Apply to Products with Metal Pins)..... | 23 |
| 13.5. | Operation | 24 |
| 13.6. | Static Electricity | 24 |
| 13.7. | Limited Warranty | 24 |
| 14. | Packaging..... | 25 |
| 15. | Outline Drawing..... | 26 |

1. General Description

The specification is a transmissive type color active matrix liquid crystal display (LCD) which uses amorphous thin film transistor (TFT) as switching devices. This product is composed of a TFT-LCD panel, driver lcs and a backlight unit.

2. Module Parameter

| Features | Details | Unit |
|-----------------------------|--------------------------------------|------------|
| Display Size(Diagonal) | 8.0" | |
| LCD type | IPS TFT | |
| Display Mode | Transmissive /normally black | |
| Resolution | 1024*(RGB) x 768 | Pixels |
| View Direction | FULL VIEW | Best Image |
| Module Outline | 175.26(H) x142(V) x 2.95(T) (Note1) | mm |
| Active Area | 162.05(H) x121.54(V) | mm |
| Pixel Size | 158(H)x158(V) | um |
| Pixel Arrangement | R.G.B. Vertical Stripe | |
| Surface treatment | Hard coating | |
| Display Colors | 16.7M | |
| Interface | 6 bit/8 bit -LVDS interface | |
| With or Without Touch Panel | Without | |
| Operating Temperature | -20~70 | °C |
| Storage Temperature | -30~70 | °C |
| Weight | 142 | g |

Note 1: Exclusive hooks, posts , FFC/FPC tail etc.

3. Absolute Maximum Ratings

$V_{SS}=0V, T_a=25^{\circ}C$

| Item | Symbol | Min. | Max. | Unit |
|-----------------------|------------------|---------|------------|------|
| Supply Voltage | VDD | (-0.3) | (5.0) | V |
| | AVDD | (6.5) | (13.5) | V |
| | VGH | (-0.3) | (VGL+40.0) | V |
| | VGL | (-20.0) | (0.3) | V |
| Storage temperature | T _{stg} | -30 | +70 | °C |
| Operating temperature | T _{op} | -20 | +70 | °C |

Note 1: If T_a below $50^{\circ}C$, the maximal humidity is 90%RH, if T_a over $50^{\circ}C$, absolute humidity should be less than 60%RH.

Note 2: The response time will be extremely slow when the operating temperature is around $-10^{\circ}C$, and the back ground will become darker at high temperature operating.

4. DC Characteristics

| Item | Symbol | Min. | Typ. | Max. | Unit |
|----------------------------------|----------------------------------|-----------|--------|-----------|------|
| Supply Voltage | VDD | (3.0) | (3.3) | (3.6) | V |
| | AVDD | (9.8) | (10) | (10.2) | V |
| | VGH | (18.6) | (18.9) | (19.2) | V |
| | VGL | (-8.1) | (-7.8) | (-7.5) | V |
| Input signal voltage | VCOM | (2.6) | (3.6) | (4.6) | V |
| Input logic high voltage | VIH | (0.7*VDD) | - | (VDD) | V |
| Input logic low voltage | VIL | 0 | - | (0.3*VDD) | V |
| Current Consumption All White | I _{CC+} I _{IN} | - | TBD | - | mA |

Note 1:Be sure to apply VCC and VGL to the LCD first,and then apply VGH

Note 2:VCC setting should match the signal output voltage (refer to Note 3)of customer's system board

Note 3:Typical Vcom is only a reference value ,it must be optimized according to each LCM

Note 4:DCLK,HS,VS,RSTB,UPDN,STLR,MODE,DITHB

5. Backlight Characteristic

5.1. Backlight Characteristic

| Item | Symbol | Condition | Min | Typ | Max | Unit |
|-------------------|--|--------------------------------|-----|-------|-----|------|
| Forward Voltage | V _F | Ta=25 °C, I _F =20mA | - | 9.8 | - | V |
| Forward Current | I _F | Ta=25 °C, V _F =9.8V | - | 240*2 | - | mA |
| Power dissipation | P _d | | - | 4704 | - | W |
| Uniformity | Avg | | 65 | - | - | % |
| Drive method | Constant current | | | | | |
| LED Configuration | 72 White LEDs (3 LEDs in one string and 12 groups in parallel)*2 | | | | | |

5.2. Backlighting circuit

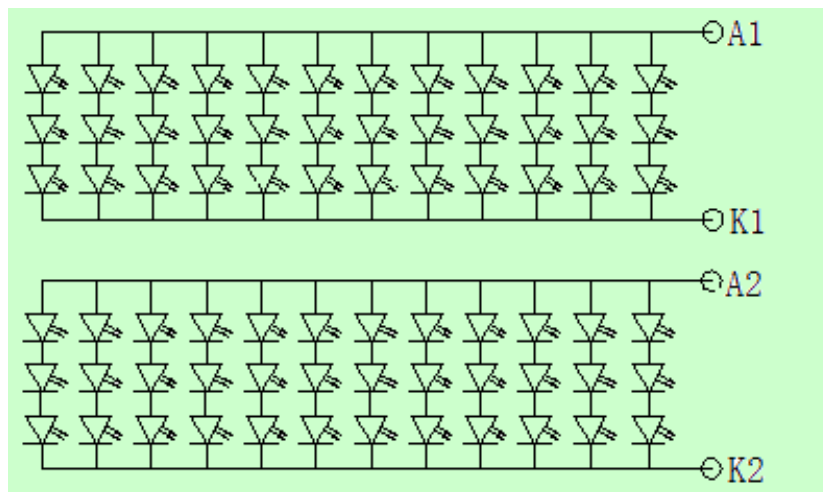

6. Optical Characteristics

6.1. Optical Characteristics

Ta=25°C, VDD=3.3V

| | Item | Symbol | Condition | Specification | | | Unit | |
|----------------------------------|--|-----------------|-----------------|---------------|-------|-------|-------------------|------|
| | | | | Min. | Typ. | Max. | | |
| Backlight On (Transmissive Mode) | Luminance on TFT($I_f=20\text{mA/LED}$) | Lv | | 640 | 800 | - | cd/m ² | |
| | Contrast ratio(See 6.3) | CR | | 500 | 800 | - | | |
| | Response time (See 6.2) | TR+TF | | - | 39 | 78 | ms | |
| | Chromaticity Transmissive (See 6.5) | Red | X _R | Center CR≥10 | 0.533 | 0.583 | 0.633 | |
| | | | Y _R | | 0.289 | 0.339 | 0.389 | |
| | | Green | X _G | | 0.252 | 0.302 | 0.352 | |
| | | | Y _G | | 0.563 | 0.613 | 0.663 | |
| | | Blue | X _B | | 0.095 | 0.145 | 0.195 | |
| | | | Y _B | | 0.070 | 0.120 | 0.170 | |
| | White | X _W | 0.231 | 0.281 | 0.331 | | | |
| | | Y _W | 0.296 | 0.346 | 0.396 | | | |
| | Viewing Angle (See 6.4) | Horizontal | θ _{X+} | Center CR≥10 | 75 | 85 | - | Deg. |
| | | | θ _{X-} | | 75 | 85 | - | |
| Vertical | | φ _{Y+} | 75 | | 85 | - | | |
| | | φ _{Y-} | 75 | | 85 | - | | |

6.2. Definition of Response Time

6.2.1. Normally Black Type (Negative)

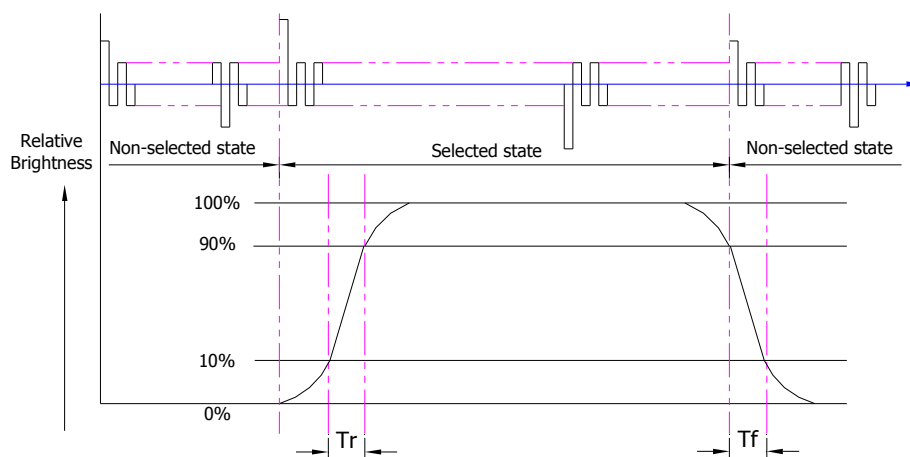

Tr is the time it takes to change from non-selected stage with relative luminance 10% to selected state with relative luminance 90%;

Tf is the time it takes to change from selected state with relative luminance 90% to non-selected state with relative luminance 10%.

Note : Measuring machine: LCD-5100

6.2.2. Normally White Type (Positive)

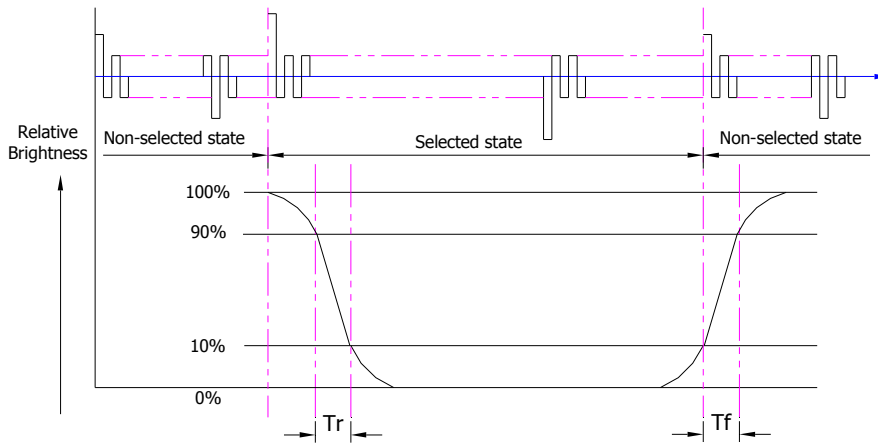

Tr is the time it takes to change from non-selected state with relative luminance 90% to selected state with relative luminance 10%;

Tf is the time it takes to change from selected state with relative luminance 10% to non-selected state with relative luminance 90%;

Note : Measuring machine: LCD-5100 or EQUI

6.3. Definition of Contrast Ratio

Contrast is measured perpendicular to display surface in reflective and transmissive mode.

The measurement condition is:

| | |
|--------------------------|---|
| Measuring Equipment | Eldim or Equivalent |
| Measuring Point Diameter | 3mm//1mm |
| Measuring Point Location | Active Area centre point |
| Test pattern | A: All Pixels white B: All Pixel black |
| Contrast setting | Maximum |

Definitions: CR (Contrast) = Luminance of White Pixel / Luminance of Black Pixel

6.4. Definition of Viewing Angles

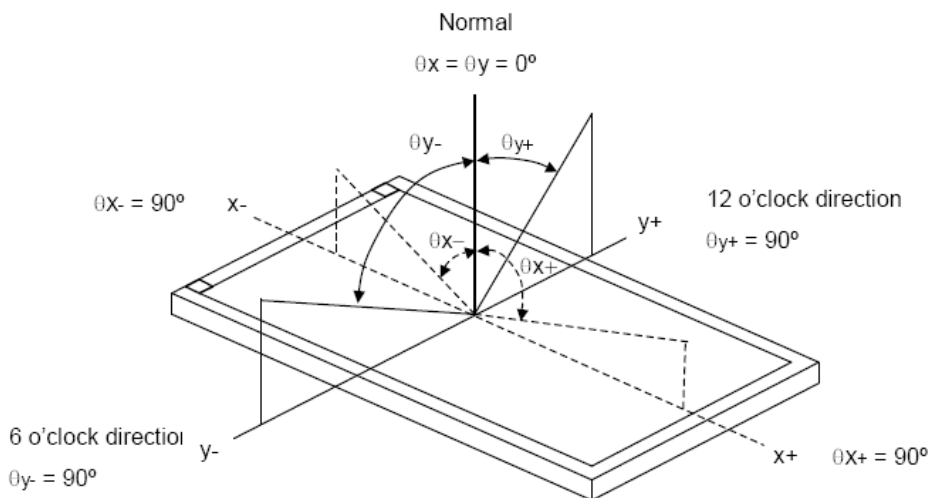

Measuring machine: LCD-5100 or EQUI

6.5. Definition of Color Appearance

R,G,B and W are defined by (x, y) on the IE chromaticity diagram

NTSC=area of RGB triangle/area of NTSC triangleX100%

Measuring picture: Red, Green, Blue and White (Measuring machine: BM-7)

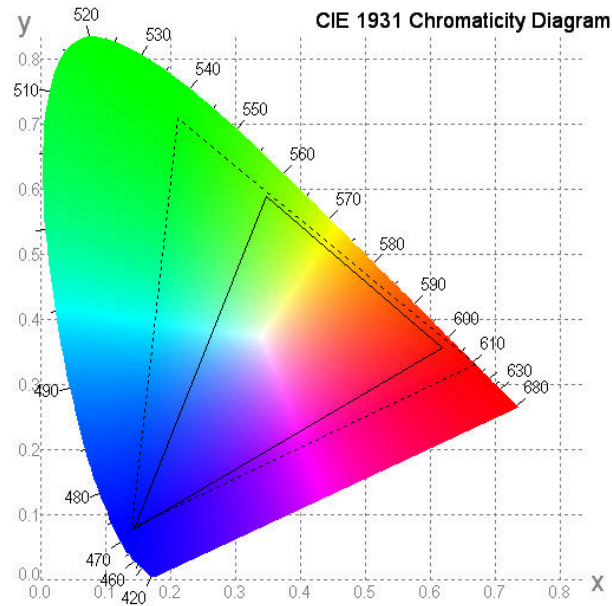

6.6. Definition of Surface Luminance, Uniformity and Transmittance

Using the transmissive mode measurement approach, measure the white screen luminance of the display panel and backlight.

- 6.6.1. Surface Luminance: $L_V = \text{average} (L_{P1}:L_{P9})$
- 6.6.2. Uniformity = $\text{Minimal} (L_{P1}:L_{P9}) / \text{Maximal} (L_{P1}:L_{P9}) * 100\%$
- 6.6.3. Transmittance = $L_V \text{ on LCD} / L_V \text{ on Backlight} * 100\%$

Note : Measuring machine: BM-7

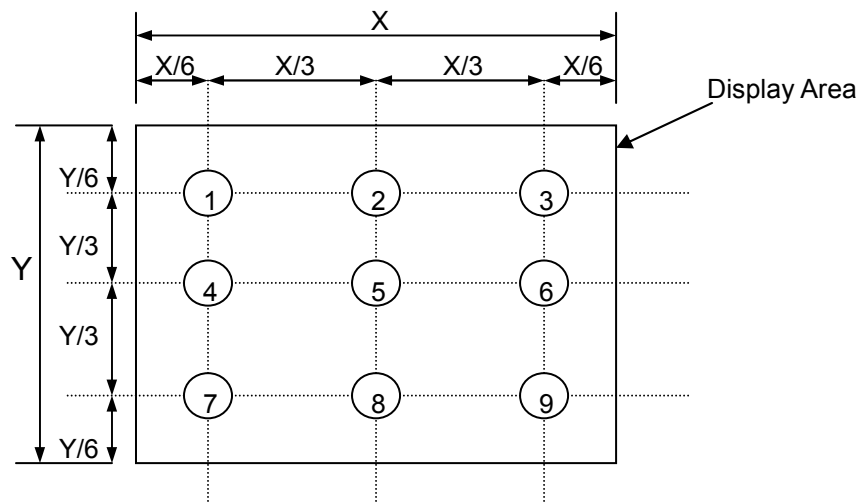

7. Block Diagram and Power Supply

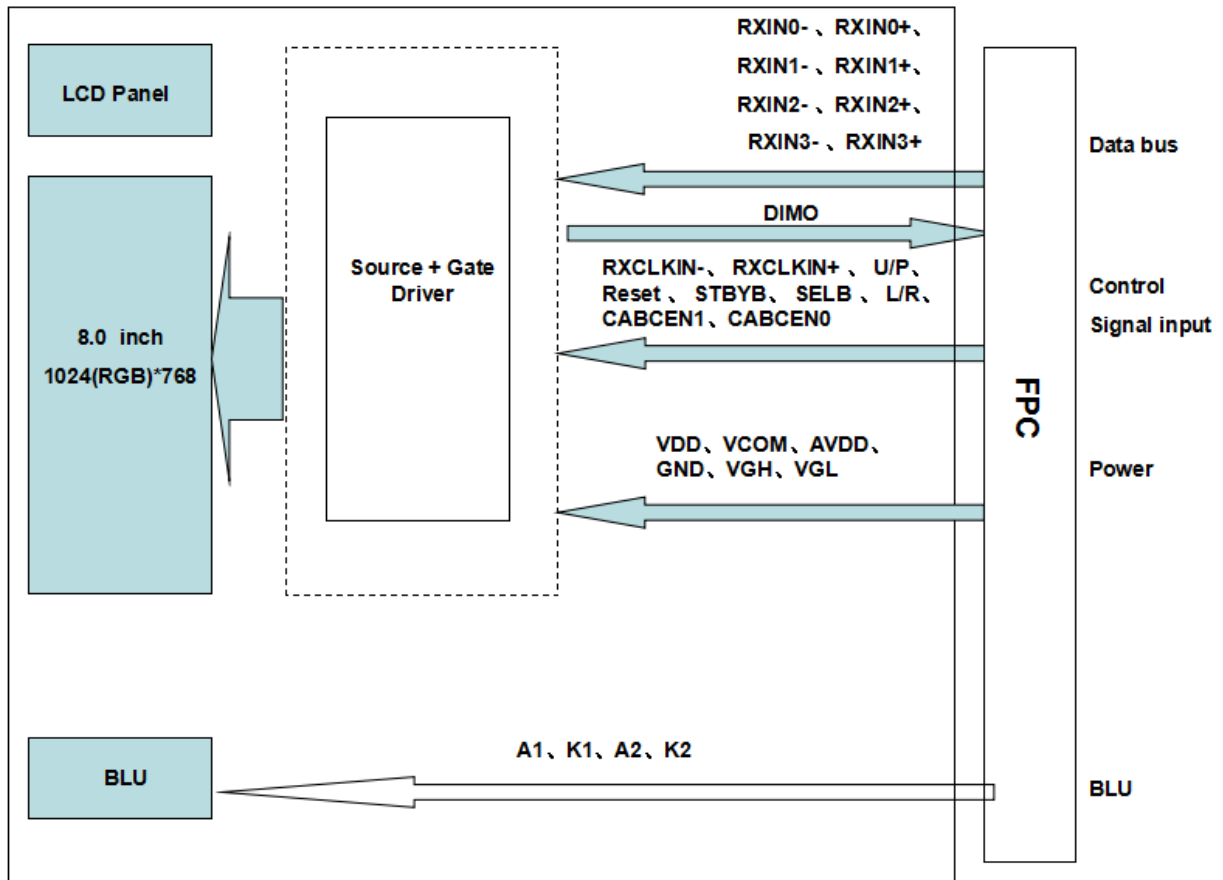

8. Interface Pins Definition

1)FH12A-40S-0.5SH

| No. | Symbol | Function | Remark |
|-----|----------|---|--------|
| 1 | VCOM | Common Voltage | |
| 2 | VDD | Power Voltage for digital circuit | |
| 3 | VDD | Power Voltage for digital circuit | |
| 4 | NC | No connection | |
| 5 | Reset | Global reset pin | |
| 6 | STBYB | Standby mode normally pulled high | |
| 7 | GND | Ground | |
| 8 | RXIN0- | -LVDS differential data input | |
| 9 | RXIN0+ | +LVDS differential data input | |
| 10 | GND | Ground | |
| 11 | RXIN1- | -LVDS differential data input | |
| 12 | RXIN1+ | +LVDS differential data input | |
| 13 | GND | Ground | |
| 14 | RXIN2- | -LVDS differential data input | |
| 15 | RXIN2+ | +LVDS differential data input | |
| 16 | GND | Ground | |
| 17 | RXCLKIN- | -LVDS differential clock input | |
| 18 | RXCLKIN+ | +LVDS differential clock input | |
| 19 | GND | Ground | |
| 20 | RXIN3- | -LVDS differential data input | |
| 21 | RXIN3+ | +LVDS differential data input | |
| 22 | GND | Ground | |
| 23 | NC | No connection | |
| 24 | NC | No connection | |
| 25 | GND | Ground | |
| 26 | NC | No connection | |
| 27 | DIMO | Backlight CABC controller signal output | |
| 28 | SELB | 6bit/8bit mode select | Note1 |
| 29 | AVDD | Power for Analog Circuit | |
| 30 | GND | Ground | |
| 31 | LED- | No connection | |
| 32 | LED- | No connection | |
| 33 | L/R | Horizontal inversion | Note3 |
| 34 | U/D | Vertical inversion | Note3 |
| 35 | VGL | Gate OFF Voltage | |
| 36 | CABCEN1 | CABC H/W enable | Note2 |
| 37 | CABCEN0 | CABC H/W enable | Note2 |
| 38 | VGH | Gate ON Voltage | |
| 39 | LED+ | No connection | |

| | | | |
|----|------|---------------|--|
| 40 | LED+ | No connection | |
|----|------|---------------|--|

2)Connection:BHSR-02VS-1

| Symbol | Color | Function |
|--------|-------|-------------|
| A1 | Red | LED Anode |
| K1 | Black | LED Cathode |
| A2 | Red | LED Anode |
| K2 | Black | LED Cathode |

Note1: If LVDS input data is 6 bits ,SELB must be set to High;
If LVDS input data is 8 bits ,SELB must be set to Low.

Note2: When CABC_EN="00", CABC OFF.
When CABC_EN="01", user interface image.
When CABC_EN="10", still picture.
When CABC_EN="11", moving image.
When CABC off, don't connect DIMO, else connect it to backlight.

Note3: When L/R="0", set right to left scan direction.
When L/R="1", set left to right scan direction.
When U/D="0", set top to bottom scan direction.
When U/D="1", set bottom to top scan direction.

Note: Definition of scanning direction.
Refer to the figure as below:

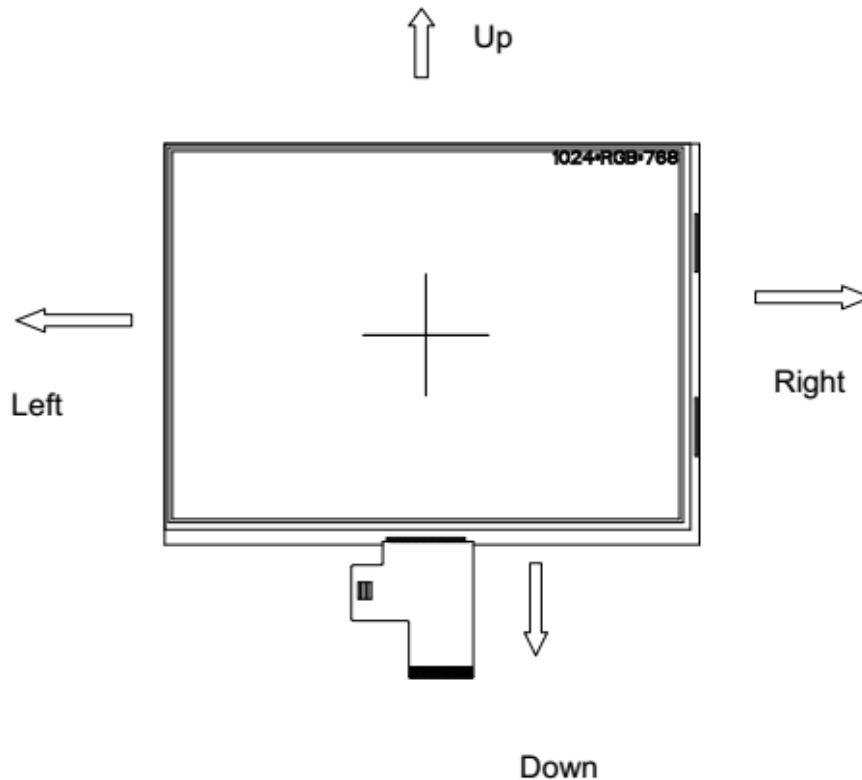

9. Power Sequence

1)

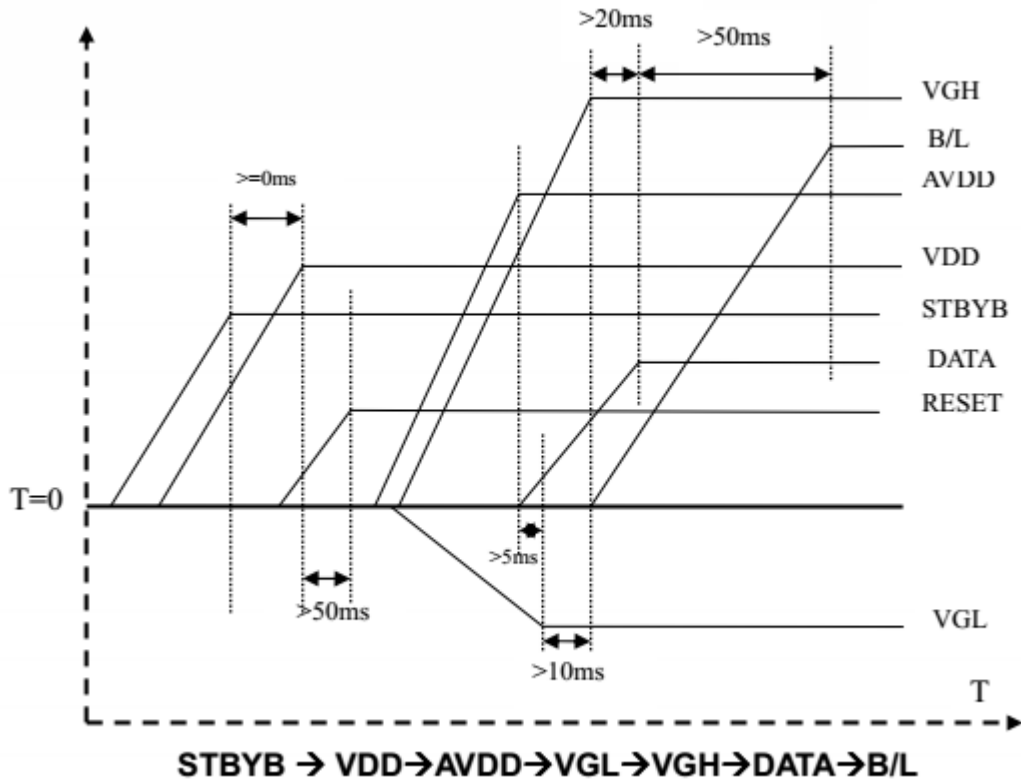

2)

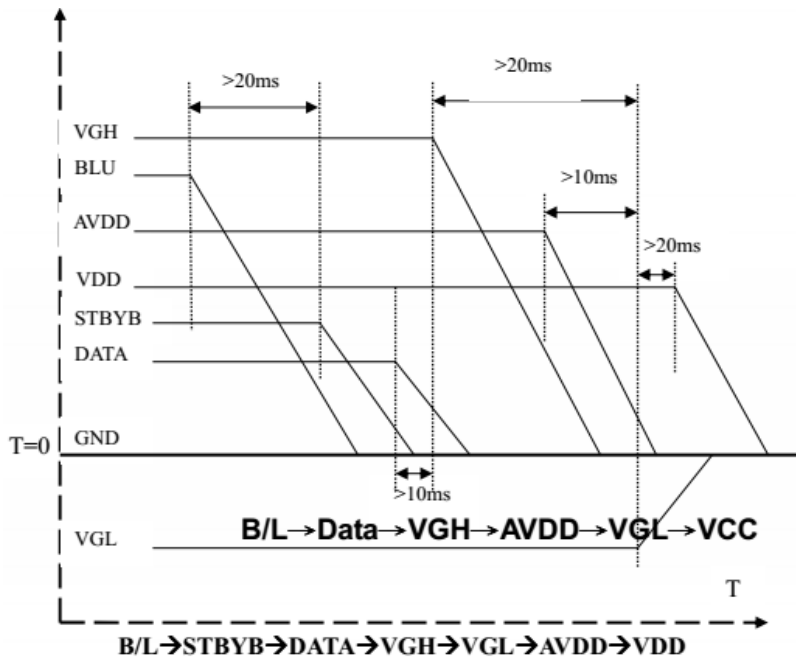

10. Timing Characteristics

10.1 AC Electrical Characteristics

| Parameter | Symbol | Values | | | Unit | Remark |
|------------------------|-------------|--------|---------------------|------|------|--------|
| | | Min. | Typ. | Max. | | |
| Clock frequency | R_{xFCLK} | 20 | - | 71 | MHz | |
| Input data skew margin | T_{RSKM} | 500 | - | - | ps | |
| Clock high time | T_{LVCH} | - | $4/(7 * R_{xFCLK})$ | - | ns | |
| Clock low time | T_{LVCL} | - | $3/(7 * R_{xFCLK})$ | - | ns | |

10.2 Input Clock and Data Timing Diagram

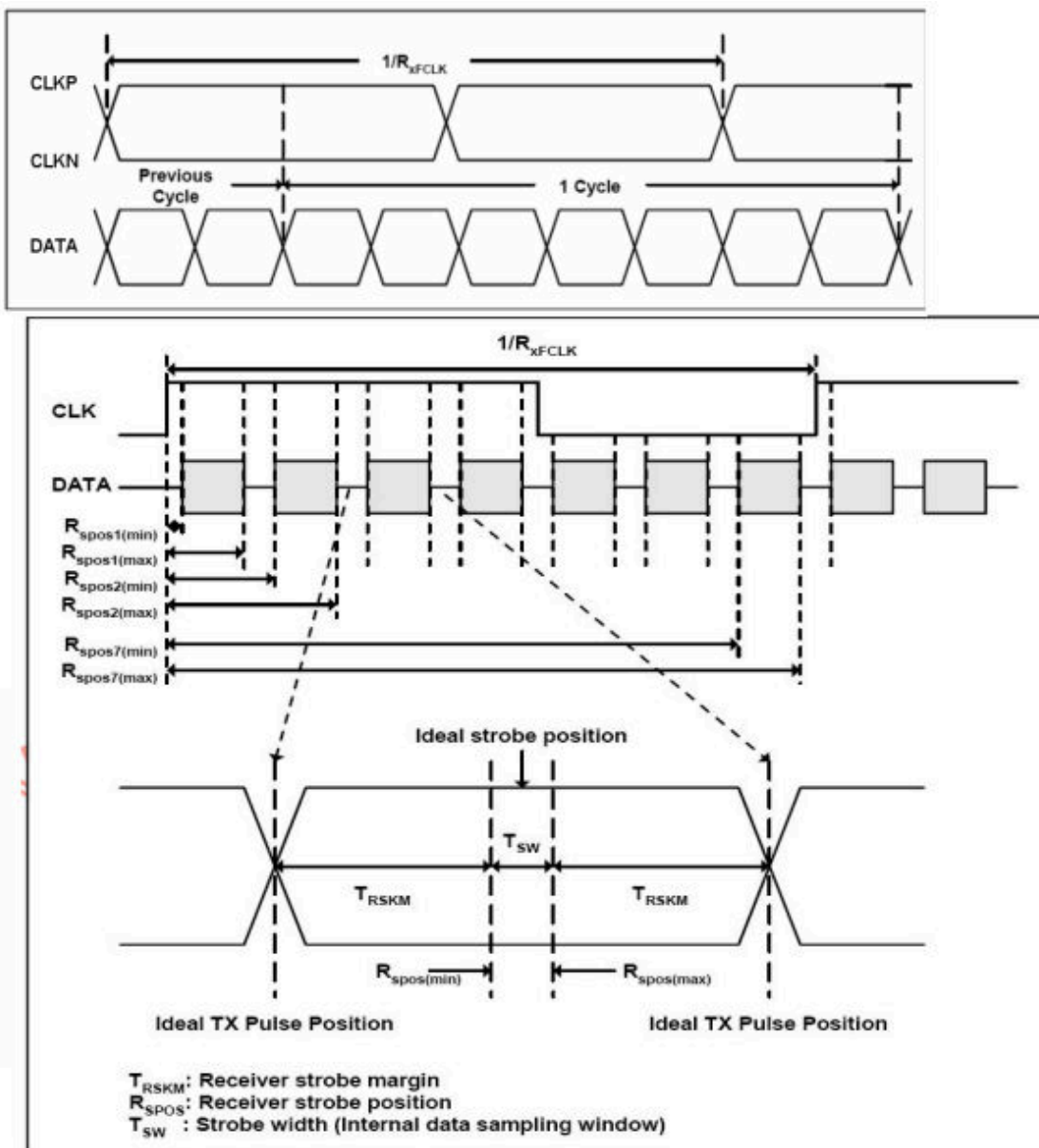

10.3 DC Electrical Characteristics

| Parameter | Symbol | Values | | | Unit | Remark |
|---|----------------|--------------|------|------------------|---------|-----------------|
| | | Min. | Typ. | Max. | | |
| Differential input high Threshold voltage | R_{xVTH} | - | - | +0.1 | V | $R_{xVCM}=1.2V$ |
| Differential input low Threshold voltage | R_{xVTH} | -0.1 | - | - | V | |
| Input voltage range (singled-end) | R_{xVIN} | 0 | - | 2.4 | V | |
| Differential input common mode voltage | R_{xVCM} | $ V_{ID} /2$ | - | $2.4- V_{ID} /2$ | V | |
| Differential voltage | $ V_{ID} $ | 0.2 | - | 0.6 | V | |
| Differential input leakage current | $R_{V_{xIIZ}}$ | -10 | - | +10 | μA | |

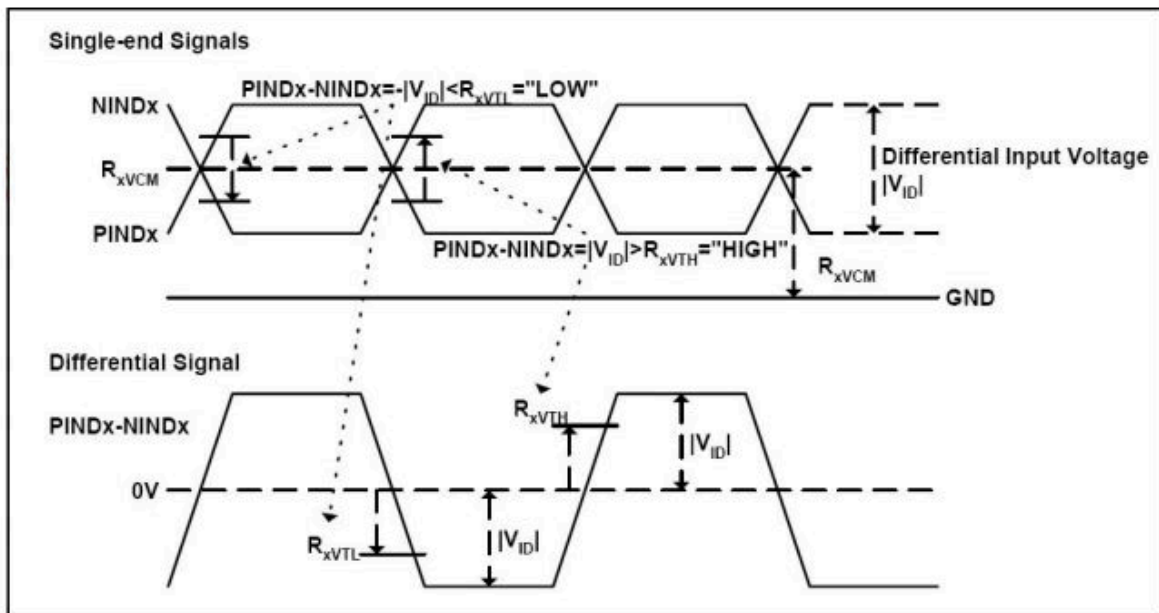

10.4 Timing

| Item | Symbol | Values | | | Unit | Remark |
|-------------------------|--------|--------|------|------|------|------------|
| | | Min. | Typ. | Max. | | |
| Clock Frequency | fclk | 52 | 65 | 71 | MHz | Frame rate |
| Horizontal display area | thd | 1024 | | | DCLK | |
| HS period time | th | 1114 | 1344 | 1400 | DCLK | |
| HS Blanking | thb | 90 | 320 | 376 | DCLK | |
| Vertical display area | tvd | 768 | | | H | |
| VS period time | tv | 778 | 806 | 845 | H | |
| VS Blanking | thb | 10 | 38 | 77 | H | |

10.5 Data Input Format

6bit LVDS input

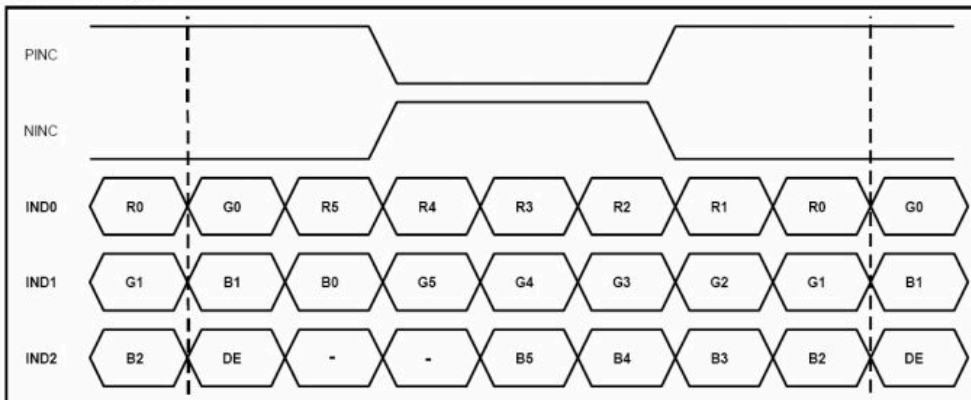

8bit LVDS input

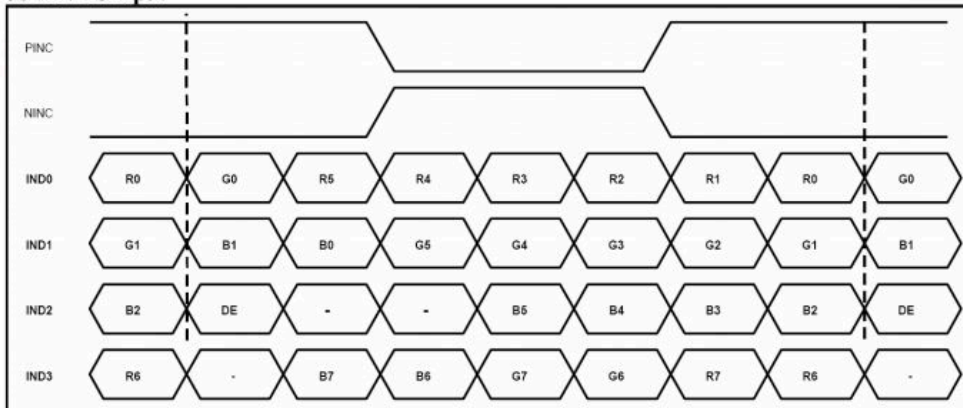

Note: Support DE timing mode only, SYNC mode not supported.

11. Quality Assurance

11.1 Purpose

This standard for Quality Assurance assures the quality of LCD module products supplied to customer.

11.2 Standard for Quality Test

11.2.1 Sampling Plan:

GB2828.1-2012

Single sampling, general inspection level II

11.2.2 Sampling Criteria:

Visual inspection: AQL 1.5%

Electrical functional: AQL 0.65%.

11.2.3 Reliability Test:

Detailed requirement refer to Reliability Test Specification.

11.3 Nonconforming Analysis & Disposition

11.3.1 Nonconforming analysis:

11.3.1.1 Customer should provide overall information of non-conforming sample for their complaints.

11.3.1.2 After receipt of detailed information from customer, the analysis of nonconforming parts usually should be finished in one week.

11.3.1.3 If can not finish the analysis on time, customer will be notified with the progress status.

11.3.2 Disposition of nonconforming:

11.3.2.1 Non-conforming product over PPM level will be replaced.

11.3.2.2 The cause of non-conformance will be analyzed. Corrective action will be discussed and implemented.

11.4 Agreement Items

Shall negotiate with customer if the following situation occurs:

11.4.1 There is any discrepancy in standard of quality assurance.

11.4.2 Additional requirement to be added in product specification.

11.4.3 Any other special problem.

11.5 Standard of the Product Visual Inspection

11.5.1 Appearance inspection:

11.5.1.1 The inspection must be under illumination about 1000 – 1500 lx, and the distance of view must be at 30cm ± 2cm.

11.5.1.2 The viewing angle should be 45° from the vertical line without reflection light or follows customer's viewing angle specifications.

11.5.1.3 Definition of area: A Zone: Active Area, B Zone: Viewing Area,

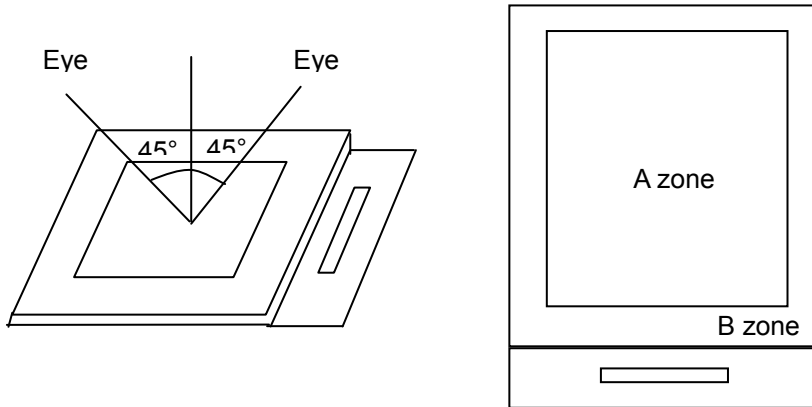

11.5.2 Basic principle:

11.5.2.1 A set of sample to indicate the limit of acceptable quality level must be discussed by both us and customer when there is any dispute happened.

12.5.2.2 New item must be added on time when it is necessary.

11.6 Inspection Specification

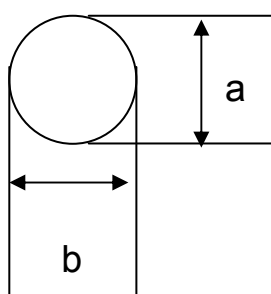
| No. | Item | Criteria (Unit: mm) | | | | | | | | | | | | | | | | | | |
|-------------------------|---|---|------------|--------------|----------|------------------|--|------------|-------------------------|----------|------------|---------------|-----------|------------|------------|--|------|------------------------------------|--|--------|
| 01 | Black / White spot Foreign material (Round type) Pinholes Stain Particles inside cell. (Minor defect) |  <table border="1" data-bbox="893 1075 1388 1288"> <thead> <tr> <th>Size</th> <th>Area</th> <th>Acc. Qty</th> </tr> </thead> <tbody> <tr> <td>$\phi \leq 0.20$</td> <td></td> <td>Ignore</td> </tr> <tr> <td>$0.20 < \phi \leq 0.50$</td> <td></td> <td>$N \leq 3$</td> </tr> <tr> <td>$0.50 < \phi$</td> <td></td> <td>0</td> </tr> </tbody> </table> <p>$\phi = (a + b) / 2$ Distance between 2 defects should more than 5mm apart.</p> | Size | Area | Acc. Qty | $\phi \leq 0.20$ | | Ignore | $0.20 < \phi \leq 0.50$ | | $N \leq 3$ | $0.50 < \phi$ | | 0 | | | | | | |
| Size | Area | Acc. Qty | | | | | | | | | | | | | | | | | | |
| $\phi \leq 0.20$ | | Ignore | | | | | | | | | | | | | | | | | | |
| $0.20 < \phi \leq 0.50$ | | $N \leq 3$ | | | | | | | | | | | | | | | | | | |
| $0.50 < \phi$ | | 0 | | | | | | | | | | | | | | | | | | |
| 02 | Electrical Defect (Minor defect) | <table border="1" data-bbox="550 1478 1348 1736"> <thead> <tr> <th>Bright dot</th> <th>Display Area</th> <th>Total</th> <th rowspan="3">Note1</th> </tr> </thead> <tbody> <tr> <td></td> <td>$N \leq 2$</td> <td>$N \leq 2$</td> </tr> <tr> <td>Dark dot</td> <td>$N \leq 4$</td> <td>$N \leq 4$</td> </tr> <tr> <td>Total dot</td> <td>$N \leq 4$</td> <td>$N \leq 4$</td> <td></td> </tr> <tr> <td>Mura</td> <td colspan="2">Not visible through 5% ND filters.</td> <td>Note 2</td> </tr> </tbody> </table> <p>Remark: 1. Bright dot caused by scratch and foreign object accords to item 1.</p> | Bright dot | Display Area | Total | Note1 | | $N \leq 2$ | $N \leq 2$ | Dark dot | $N \leq 4$ | $N \leq 4$ | Total dot | $N \leq 4$ | $N \leq 4$ | | Mura | Not visible through 5% ND filters. | | Note 2 |
| Bright dot | Display Area | Total | Note1 | | | | | | | | | | | | | | | | | |
| | $N \leq 2$ | $N \leq 2$ | | | | | | | | | | | | | | | | | | |
| Dark dot | $N \leq 4$ | $N \leq 4$ | | | | | | | | | | | | | | | | | | |
| Total dot | $N \leq 4$ | $N \leq 4$ | | | | | | | | | | | | | | | | | | |
| Mura | Not visible through 5% ND filters. | | Note 2 | | | | | | | | | | | | | | | | | |

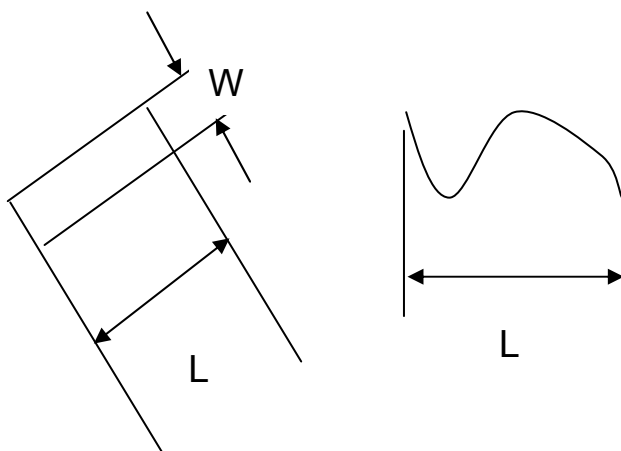
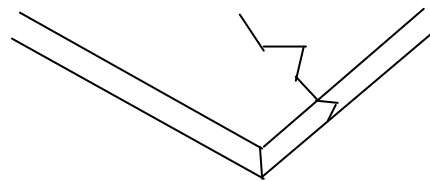
| <p>03</p> | <p>Black and White line Scratch Foreign material (Line type) (Minor defect)</p> |  <table border="1" data-bbox="614 750 1236 1008"> <thead> <tr> <th>Length</th> <th>Width</th> <th>Acc. Qty</th> </tr> </thead> <tbody> <tr> <td>/</td> <td>$W \leq 0.1$</td> <td>Ignore</td> </tr> <tr> <td>$L \leq 2.5$</td> <td>$0.1 < W \leq 0.2$</td> <td>3</td> </tr> <tr> <td>$L > 2.5$</td> <td>$0.2 < W$</td> <td>0</td> </tr> <tr> <td colspan="2">Total</td> <td>3</td> </tr> </tbody> </table> <p>Distance between 2 defects should more than 3mm apart. Scratches not viewable through the back of the display are acceptable.</p> | Length | Width | Acc. Qty | / | $W \leq 0.1$ | Ignore | $L \leq 2.5$ | $0.1 < W \leq 0.2$ | 3 | $L > 2.5$ | $0.2 < W$ | 0 | Total | | 3 |
|--------------|---|--|--------|-------|----------|---|--------------|--------|--------------|--------------------|---|-----------|-----------|---|-------|--|---|
| Length | Width | Acc. Qty | | | | | | | | | | | | | | | |
| / | $W \leq 0.1$ | Ignore | | | | | | | | | | | | | | | |
| $L \leq 2.5$ | $0.1 < W \leq 0.2$ | 3 | | | | | | | | | | | | | | | |
| $L > 2.5$ | $0.2 < W$ | 0 | | | | | | | | | | | | | | | |
| Total | | 3 | | | | | | | | | | | | | | | |
| <p>04</p> | <p>Glass Crack (Minor defect)</p> |  <p>Crack is potential to enlarge, any type is not allowed.</p> | | | | | | | | | | | | | | | |

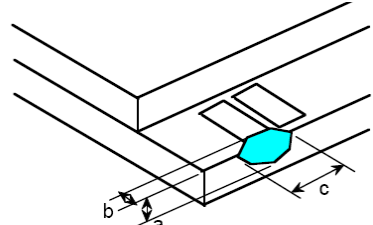
| <p>05</p> | <p>Glass Chipping Pad Area: (Minor defect)</p>  | <table border="1" data-bbox="861 1724 1332 1892"> <thead> <tr> <th>Length and Width</th> <th>Acc. Qty</th> </tr> </thead> <tbody> <tr> <td>$c > 3.0, b < 1.0$</td> <td>1</td> </tr> <tr> <td>$c < 3.0, b < 1.0$</td> <td>3</td> </tr> <tr> <td colspan="2">$a < \text{Glass Thickness}$</td> </tr> </tbody> </table> | Length and Width | Acc. Qty | $c > 3.0, b < 1.0$ | 1 | $c < 3.0, b < 1.0$ | 3 | $a < \text{Glass Thickness}$ | |
|------------------------------|--|--|------------------|----------|--------------------|---|--------------------|---|------------------------------|--|
| Length and Width | Acc. Qty | | | | | | | | | |
| $c > 3.0, b < 1.0$ | 1 | | | | | | | | | |
| $c < 3.0, b < 1.0$ | 3 | | | | | | | | | |
| $a < \text{Glass Thickness}$ | | | | | | | | | | |

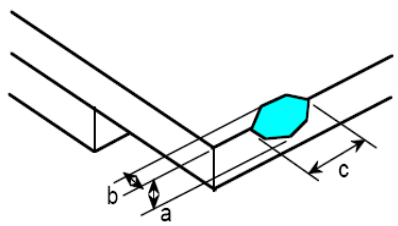
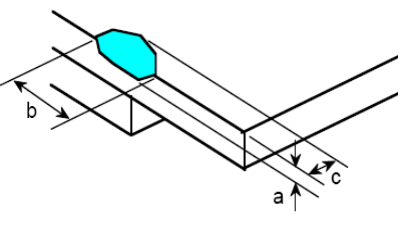
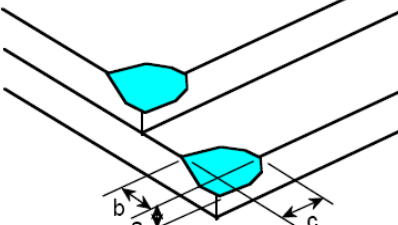
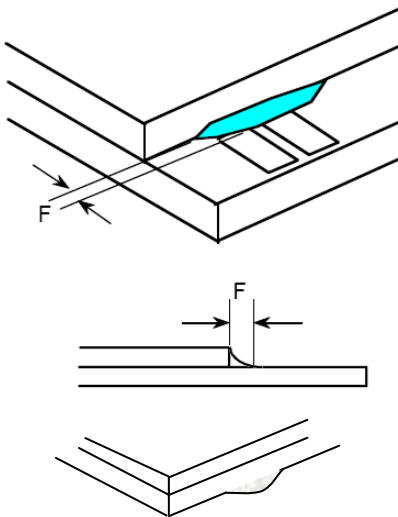
| <p>06</p> | <p>Glass Chipping Rear of Pad Area: (Minor defect)</p>  | <table border="1"> <thead> <tr> <th>Length and Width</th> <th>Acc. Qty</th> </tr> </thead> <tbody> <tr> <td>$c > 3.0, b < 1.0$</td> <td>1</td> </tr> <tr> <td>$c < 3.0, b < 1.0$</td> <td>2</td> </tr> <tr> <td>$c < 3.0, b < 0.5$</td> <td>4</td> </tr> <tr> <td colspan="2" style="text-align: center;">$a < \text{Glass Thickness}$</td> </tr> </tbody> </table> | Length and Width | Acc. Qty | $c > 3.0, b < 1.0$ | 1 | $c < 3.0, b < 1.0$ | 2 | $c < 3.0, b < 0.5$ | 4 | $a < \text{Glass Thickness}$ | |
|------------------------------|--|--|------------------|----------|--------------------|--------|------------------------------|---|--------------------|---|------------------------------|--|
| Length and Width | Acc. Qty | | | | | | | | | | | |
| $c > 3.0, b < 1.0$ | 1 | | | | | | | | | | | |
| $c < 3.0, b < 1.0$ | 2 | | | | | | | | | | | |
| $c < 3.0, b < 0.5$ | 4 | | | | | | | | | | | |
| $a < \text{Glass Thickness}$ | | | | | | | | | | | | |
| <p>07</p> | <p>Glass Chipping Except Pad Area: (Minor defect)</p>  | <table border="1"> <thead> <tr> <th>Length and Width</th> <th>Acc. Qty</th> </tr> </thead> <tbody> <tr> <td>$c > 3.0, b < 1.0$</td> <td>1</td> </tr> <tr> <td>$c < 3.0, b < 1.0$</td> <td>2</td> </tr> <tr> <td>$c < 3.0, b < 0.5$</td> <td>4</td> </tr> <tr> <td colspan="2" style="text-align: center;">$a < \text{Glass Thickness}$</td> </tr> </tbody> </table> | Length and Width | Acc. Qty | $c > 3.0, b < 1.0$ | 1 | $c < 3.0, b < 1.0$ | 2 | $c < 3.0, b < 0.5$ | 4 | $a < \text{Glass Thickness}$ | |
| Length and Width | Acc. Qty | | | | | | | | | | | |
| $c > 3.0, b < 1.0$ | 1 | | | | | | | | | | | |
| $c < 3.0, b < 1.0$ | 2 | | | | | | | | | | | |
| $c < 3.0, b < 0.5$ | 4 | | | | | | | | | | | |
| $a < \text{Glass Thickness}$ | | | | | | | | | | | | |
| <p>08</p> | <p>Glass Corner Chipping: (Minor defect)</p>  | <table border="1"> <thead> <tr> <th>Length and Width</th> <th>Acc. Qty</th> </tr> </thead> <tbody> <tr> <td>$c < 3.0, b < 3.0$</td> <td>Ignore</td> </tr> <tr> <td colspan="2" style="text-align: center;">$a < \text{Glass Thickness}$</td> </tr> </tbody> </table> | Length and Width | Acc. Qty | $c < 3.0, b < 3.0$ | Ignore | $a < \text{Glass Thickness}$ | | | | | |
| Length and Width | Acc. Qty | | | | | | | | | | | |
| $c < 3.0, b < 3.0$ | Ignore | | | | | | | | | | | |
| $a < \text{Glass Thickness}$ | | | | | | | | | | | | |
| <p>09</p> | <p>Glass Burr: (Minor defect)</p>  | <table border="1"> <thead> <tr> <th>Length</th> <th>Acc. Qty</th> </tr> </thead> <tbody> <tr> <td>$F < 1.0$</td> <td>Ignore</td> </tr> </tbody> </table> <p>Glass burr don't affect assemble and module dimension.</p> | Length | Acc. Qty | $F < 1.0$ | Ignore | | | | | | |
| Length | Acc. Qty | | | | | | | | | | | |
| $F < 1.0$ | Ignore | | | | | | | | | | | |

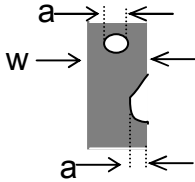
| 10 | <p>FPC Defect: (Minor defect)</p>  | <p>10.1 Dent, pinhole width $a < w/3$. (w: circuitry width.) 10.2 Open circuit is unacceptable. 10.3 No oxidation, contamination and distortion.</p> | | | | | | | | |
|----------------------------|---|---|----------|----------|---------------------|--------|----------------------------|------------|------------------|-------|
| 11 | Bubble on Polarizer (Minor defect) | <table border="1" data-bbox="737 593 1206 766"> <thead> <tr> <th>Diameter</th> <th>Acc. Qty</th> </tr> </thead> <tbody> <tr> <td>$\varphi \leq 0.30$</td> <td>Ignore</td> </tr> <tr> <td>$0.30 < \varphi \leq 0.50$</td> <td>$N \leq 2$</td> </tr> <tr> <td>$0.50 < \varphi$</td> <td>$N=0$</td> </tr> </tbody> </table> | Diameter | Acc. Qty | $\varphi \leq 0.30$ | Ignore | $0.30 < \varphi \leq 0.50$ | $N \leq 2$ | $0.50 < \varphi$ | $N=0$ |
| Diameter | Acc. Qty | | | | | | | | | |
| $\varphi \leq 0.30$ | Ignore | | | | | | | | | |
| $0.30 < \varphi \leq 0.50$ | $N \leq 2$ | | | | | | | | | |
| $0.50 < \varphi$ | $N=0$ | | | | | | | | | |
| 12 | Dent on Polarizer (Minor defect) | <table border="1" data-bbox="737 840 1206 1012"> <thead> <tr> <th>Diameter</th> <th>Acc. Qty</th> </tr> </thead> <tbody> <tr> <td>$\varphi \leq 0.25$</td> <td>Ignore</td> </tr> <tr> <td>$0.25 < \varphi \leq 0.50$</td> <td>$N \leq 4$</td> </tr> <tr> <td>$0.50 < \varphi$</td> <td>None</td> </tr> </tbody> </table> | Diameter | Acc. Qty | $\varphi \leq 0.25$ | Ignore | $0.25 < \varphi \leq 0.50$ | $N \leq 4$ | $0.50 < \varphi$ | None |
| Diameter | Acc. Qty | | | | | | | | | |
| $\varphi \leq 0.25$ | Ignore | | | | | | | | | |
| $0.25 < \varphi \leq 0.50$ | $N \leq 4$ | | | | | | | | | |
| $0.50 < \varphi$ | None | | | | | | | | | |
| 13 | Bezel | <p>13.1 No rust, distortion on the Bezel. 13.2 No visible fingerprints, stains or other contamination.</p> | | | | | | | | |
| 14 | Touch Panel | <p>D: Diameter W: width L: length 14.1 Spot: $D < 0.25$ is acceptable $0.25 \leq D \leq 0.4$ 2dots are acceptable and the distance between defects should more than 10 mm. $D > 0.4$ is unacceptable 14.2 Dent: $D > 0.40$ is unacceptable 14.3 Scratch: $W \leq 0.03$, $L \leq 10$ is acceptable, $0.03 < W \leq 0.10$, $L \leq 10$ is acceptable Distance between 2 defects should more than 10 mm. $W > 0.10$ is unacceptable.</p> | | | | | | | | |
| 15 | PCB | <p>15.1 No distortion or contamination on PCB terminals. 15.2 All components on PCB must same as documented on the BOM/component layout. 15.3 Follow IPC-A-600F.</p> | | | | | | | | |
| 16 | Soldering | Follow IPC-A-610C standard | | | | | | | | |

| | | |
|----|-------------------------------------|--|
| 17 | Electrical Defect (Major defect) | <p>The below defects must be rejected.</p> <p>17.1 Missing vertical / horizontal segment, 17.2 Abnormal Display. 17.3 No function or no display. 17.4 Current exceeds product specifications. 17.5 LCD viewing angle defect. 17.6 No Backlight. 17.7 Dark Backlight. 17.8 Touch Panel no function.</p> |
|----|-------------------------------------|--|

Remark: LCD Panel Broken shall be rejected. Defect out of LCD viewing area is acceptable.

11.7 Classification of Defects

11.7.1 Visual defects (Except no / wrong label) are treated as minor defect and electrical defect is major.

11.7.2 Two minor defects are equal to one major in lot sampling inspection.

11.8 Identification/marketing criteria

Any unit with illegible / wrong /double or no marking/ label shall be rejected.

11.9 Packing

11.9.1 There should be no damage of the outside carton box, each packaging box should have one identical label.

11.9.2 Modules inside package box should have compliant mark.

11.9.3 All direct package materials shall offer ESD protection

Note1: Bright dot is defined as the defective area of the dot is larger than 50% of one sub-pixel area.

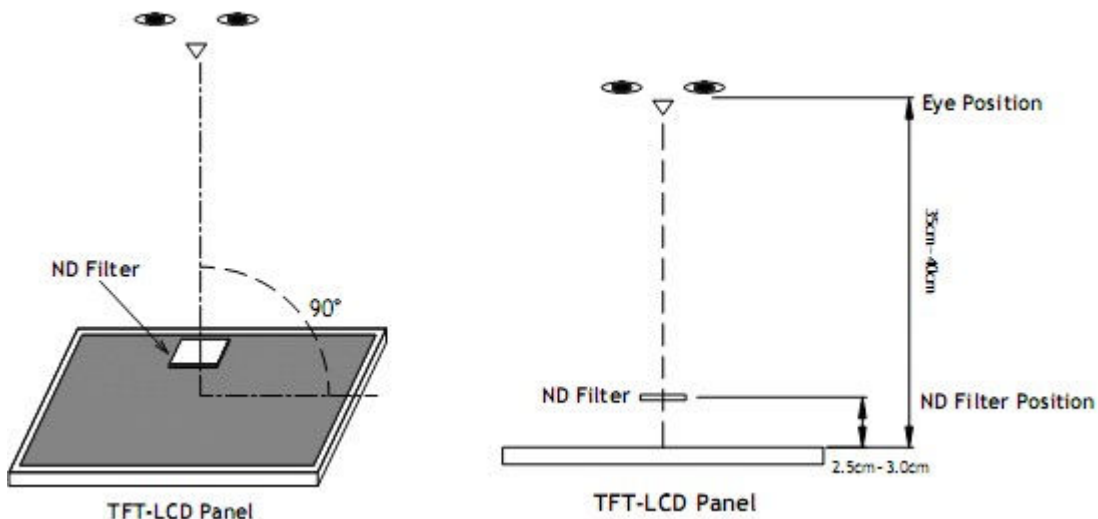

Bright dot: The bright dot size defect at black display pattern. It can be recognized by 2% transparency of filter when the distance between eyes and panel is 350mm ± 50mm.

Dark dot: Cyan, Magenta or Yellow dot size defect at white display pattern. It can be recognized by 5% transparency of filter when the distance between eyes and panel is 350mm ± 50mm.

Note2: Mura on display which appears darker / brighter against background brightness on parts of display area.

12. Reliability Specification

| No | Item | Condition | Quantity | Criteria |
|----|-----------------------------|---|----------|------------------|
| 1 | High Temperature Operating | 70°C, 96Hrs | 2 | GB/T2423.2-2008 |
| 2 | Low Temperature Operating | -20°C, 96Hrs | 2 | GB/T2423.1-2008 |
| 3 | High Humidity | 40°C, 90%RH, 96Hrs | 2 | GB/T2423.3-2006 |
| 4 | High Temperature Storage | 70°C, 96Hrs | 2 | GB/T2423.2-2008 |
| 5 | Low Temperature Storage | -30°C, 96Hrs | 2 | GB/T2423.1-2008 |
| 6 | Thermal Cycling Test | -20°C, 30min~70°C, 30min, 100 cycles. | 2 | GB/T2423.22-2012 |
| 7 | Packing vibration | Frequency range:10Hz~50Hz Acceleration of gravity:5G X, Y, Z 30 min for each direction. | 2 | GB/T5170.14-2009 |
| 8 | Electrical Static Discharge | Air: ±4KV 150pF/330 Ω 5 times Contact: ±2KV 150pF/330 Ω 5 times | 2 | GB/T17626.2-2006 |
| 9 | Drop Test (Packaged) | Height:80 cm,1 corner, 3 edges, 6 surfaces. | 2 | GB/T2423.8-1995 |

Note1. No deflection cosmetic and operational function allowable.

Note2. Total current Consumption should be below double of initial value

13. Precautions and Warranty

13.1. Safety

13.1.1 The liquid crystal in the LCD is poisonous. Do not put it in your mouth. If the liquid crystal touches your skin or clothes, wash it off immediately using soap and water.

13.1.2 Since the liquid crystal cells are made of glass, do not apply strong impact on them. Handle with care.

13.2. Handling

13.2.1 Reverse and use within ratings in order to keep performance and prevent damage.

13.2.2 Do not wipe the polarizer with dry cloth, as it might cause scratch. If the surface of the LCD needs to be cleaned, wipe it swiftly with cotton or other soft cloth soaked with petroleum IPA, do not use other chemicals.

13.3. Storage

13.3.1. Do not store the LCD module beyond the specified temperature ranges.

13.3.2. Strong light exposure causes degradation of polarizer and color filter

13.4. Metal Pin (Apply to Products with Metal Pins)

13.4.1 Pins of LCD and Backlight

13.4.1.1 Solder tip can touch and press on the tip of Pin LEAD during the soldering

13.4.1.2 Recommended Soldering Conditions

Solder Type: Sn96.3~94-Ag3.3~4.3-Cu0.4~1.1

Maximum Solder Temperature: 370℃

Maximum Solder Time: 3s at the maximum temperature

Recommended Soldering Temp: 350±20℃

Typical Soldering Time: ≤3s

13.4.1.3 Solder Wetting

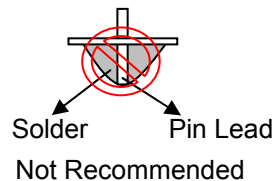
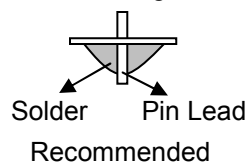

13.4.2 Pins of EL

13.4.2.1 Solder tip can touch and press on the tip of EL leads during soldering.

13.4.2.2 No Solder Paste on the soldering pad on the motherboard is recommended.

13.4.2.3 Recommended Soldering Conditions

Solder type: Nippon Alimit Leadfree SR-34, size 0.5mm

Recommended Solder Temperature: 270~290℃

Typical Soldering Time: ≤2s

Minimum solder distance from EL lamp (body):2.0mm

13.4.2.4 No horizontal press on the EL leads during soldering.

13.4.2.4 180° bend EL leads three times is not allowed.

13.4.2.5 Solder Wetting

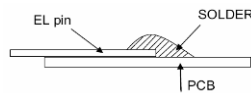

Recommended

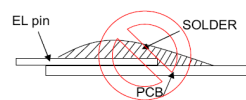

Not Recommended

13.4.2.6 The type of the solder iron:

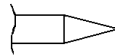

Recommended

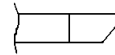

Not Recommended

13.4.2.7 Solder Pad

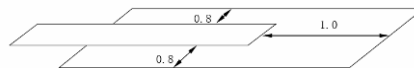

13.5. Operation

- 13.5.1. Do not drive LCD with DC voltage
- 13.5.2. Response time will increase below lower temperature
- 13.5.3. Display may change color with different temperature
- 13.5.4. Mechanical disturbance during operation, such as pressing on the display area, may cause the segments to appear “fractured”.
- 13.5.5. Do not connect or disconnect the LCM to or from the system when power is on.
- 13.5.6. Never use the LCM under abnormal condition of high temperature and high humidity.
- 13.5.7. Module has high frequency circuits. Sufficient suppression to the electromagnetic interface shall be done by system manufacturers. Grounding and shielding methods may be important to minimize the interference.
- 13.5.8. Do not display the fixed pattern for long time (we suggest the time not longer than one hour) because it may develop image sticking due to the TFT structure.

13.6. Static Electricity

- 13.6.1. CMOS LSIs are equipped in this unit, so care must be taken to avoid the electro-static charge, by ground human body, etc.
- 13.6.2. The normal static prevention measures should be observed for work clothes and benches.
- 13.6.3. The module should be kept into anti-static bags or other containers resistant to static for storage.

13.7. Limited Warranty

- 13.7.1. Our warranty liability is limited to repair and/or replacement. We will not be responsible for any consequential loss.
- 13.7.2. If possible, we suggest customer to use up all modules in six months. If the module storage time over twelve months, we suggest that recheck it before the module be used
- 13.7.3. After the product shipped, any product quality issues must be feedback within three months, otherwise, we will not be responsible for the subsequent or consequential events.

14. Packaging

TBD

15. Outline Drawing

