

PRODUCT SPECIFICATION

7.84" TFT LCD MODULE

MODEL: T078400128-A0WMN-001 Ver:1.5

ROHS

< ◇ > Preliminary Specification

< ◆ > Finally Specification

| CUSTOMER'S APPROVAL | |
|---------------------|-------|
| CUSTOMER : | |
| SIGNATURE: | DATE: |
| | |

| APPROVED BY | PM REVIEWED | PD REVIEWED | PREPARED BY |
|----------------|----------------|----------------|----------------|
| | | | |

Revision History

| Revision | Date | Originator | Detail | Remarks |
|----------|------------|------------|--|-----------------------|
| 1.0 | 2017.09.27 | ZDT | Initial Release | |
| 1.1 | 2017.11.25 | ZFY | Modify pixel size Modify luminance | P4 P6 |
| 1.2 | 2018.04.24 | ZFY | Add LED working life Modify many details | P5 P21/P22 |
| 1.3 | 2018.09.17 | WQ | Add Weight Add Current Consumption Add Chromaticity Transmissive Modify Outline Drawing | P4 P5 P6 P24 |
| 1.4 | 2019.02.26 | ZDT | Modify LED working life | P5 |
| 1.5 | 2020.02.22 | ZDT | Modify Temperature Modify Inspection Specification Modify Reliability Specification | P4 P18 P20 |
| | | | | |
| | | | | |
| | | | | |
| | | | | |
| | | | | |
| | | | | |

Table of Contents

| No. | Item | Page |
|-------|--|------|
| 1. | General Description..... | 4 |
| 2. | Module Parameter..... | 4 |
| 3. | Absolute Maximum Ratings..... | 4 |
| 4. | DC Characteristics..... | 5 |
| 5. | Backlight Characteristic..... | 5 |
| 5.1. | Backlight Characteristic..... | 5 |
| 5.2. | Backlight Characteristic..... | 5 |
| 6. | Optical Characteristics..... | 6 |
| 6.1. | Optical Characteristics..... | 6 |
| 6.2. | Definition of Response Time..... | 6 |
| 6.3. | Definition of Contrast Ratio..... | 7 |
| 6.4. | Definition of Viewing Angles..... | 7 |
| 6.5. | Definition of Color Appearance..... | 8 |
| 6.6. | Definition of Surface Luminance, Uniformity and Transmittance..... | 8 |
| 7. | Block Diagram and Power Supply..... | 9 |
| 8. | Interface Pins Definition..... | 10 |
| 9. | AC Characteristics..... | 11 |
| 9.1. | MIPI Input timing..... | 11 |
| 9.2. | MIPI AC characteristics..... | 11 |
| 10. | Reset timing..... | 13 |
| 11. | Quality Assurance..... | 14 |
| 11.1. | Purpose..... | 14 |
| 11.2. | Standard for Quality Test..... | 14 |
| 11.3. | Nonconforming Analysis & Disposition..... | 14 |
| 11.4. | Agreement Items..... | 14 |
| 11.5. | Standard of the Product Visual Inspection..... | 14 |
| 11.6. | Inspection Specification..... | 15 |
| 11.7. | Classification of Defects..... | 19 |
| 11.8. | Identification/marketing criteria..... | 19 |
| 11.9. | Packing..... | 19 |
| 12. | Reliability Specification..... | 20 |
| 13. | Precautions and Warranty..... | 21 |
| 13.1. | Safety..... | 21 |
| 13.2. | Handling..... | 21 |
| 13.3. | Storage..... | 21 |
| 13.4. | Metal Pin (Apply to Products with Metal Pins)..... | 21 |
| 13.5. | Operation..... | 22 |
| 13.6. | Static Electricity..... | 22 |
| 13.7. | Limited Warranty..... | 22 |
| 14. | Packaging..... | 23 |
| 15. | Outline Drawing..... | 24 |

1. General Description

The specification is a transmissive type color active matrix liquid crystal display (LCD) which uses amorphous thin film transistor (TFT) as switching devices. This product is composed of a TFT-LCD panel, driver Ics and a backlight unit.

2. Module Parameter

| Features | Details | Unit |
|-----------------------------|--|------------|
| Display Size(Diagonal) | 7.8" | |
| LCD type | IPS TFT | |
| Display Mode | Transmissive /Normally black | |
| Resolution | 400 RGB x 1280 | Pixels |
| View Direction | FULL VIEW | Best Image |
| Module Outline | 67.5(H) x 202.58 (V) x 2.6(T) (Note1) | mm |
| Active Area | 59.4 (H) x 190.08(V) | mm |
| Pixel Size | 148.5 (H) x 148.5 (V) | um |
| Pixel Arrangement | Stripe | |
| Display Colors | 16.7M | |
| Interface | MIPI | |
| With or without touch panel | Without | |
| Driver IC | EK79030 | - |
| Operating Temperature | -20~50 | °C |
| Storage Temperature | -30~80 | °C |
| Weight | 79 | g |

Note 1: Exclusive hooks, posts, FFC/FPC tail etc.

3. Absolute Maximum Ratings

$V_{SS}=0V$, $T_a=25^{\circ}C$

| Item | Symbol | Min. | Max. | Unit |
|-----------------------|------------------|------------|------------|------|
| Supply Voltage | V _{CI} | 2.5 | 6.0 | V |
| | IOVCC | 1.8 | 5.5 | V |
| Storage temperature | T _{STG} | -30 | +80 | °C |
| Operating temperature | T _{OP} | -20 | +50 | °C |

Note 1: If T_a below $50^{\circ}C$, the maximal humidity is 90%RH, if T_a over $50^{\circ}C$, absolute humidity should be less than 60%RH.

Note 2: The response time will be extremely slow when the operating temperature is around $-10^{\circ}C$, and the back ground will become darker at high temperature operating.

4. DC Characteristics

| Item | Symbol | Min. | Typ. | Max. | Unit | |
|----------------------------------|-----------------|----------------------|------|-----------|------|----|
| Supply Voltage | V _{CI} | 2.5 | 3.3 | 3.6 | V | |
| | IOVCC | 1.8 | 3.3 | 3.6 | V | |
| VDDIO Input low level voltage | V _{IL} | VSS | - | 0.2*IOVCC | mV | |
| VDDIO Input high level voltage | V _{IH} | 0.8*IOVCC | - | IOVCC | mV | |
| Current Consumption All white | Logic Analog | I _{CC+ IIN} | - | 17 | - | mA |

5. Backlight Characteristic

5.1. Backlight Characteristic

| Item | Symbol | Condition | Min. | Typ. | Max. | Unit |
|------------------------|---|---|-----------|------------|-----------|------|
| Forward Voltage | V _F | T _a =25 °C, I _F =20mA/LED | 11 | 12 | 13 | V |
| Forward Current | I _F | T _a =25 °C, V _F =6V/LED | - | 120 | - | mA |
| Power dissipation | P _D | | - | 1440 | - | mW |
| Uniformity | Avg | | 70 | 80 | - | % |
| LED working life(25°C) | - | | - | 15,000 | - | Hrs |
| Drive method | Constant current | | | | | |
| LED Configuration | 12 White LEDs (2 LEDs in one string and 6 groups in parallel) | | | | | |

Note1: LED life time defined as follows: The final brightness is at 50% of original brightness.

The environmental conducted under ambient air flow, at T_a=25±2 °C,60%RH±5%, I_F=20mA/LED.

5.2. Backlight Characteristic

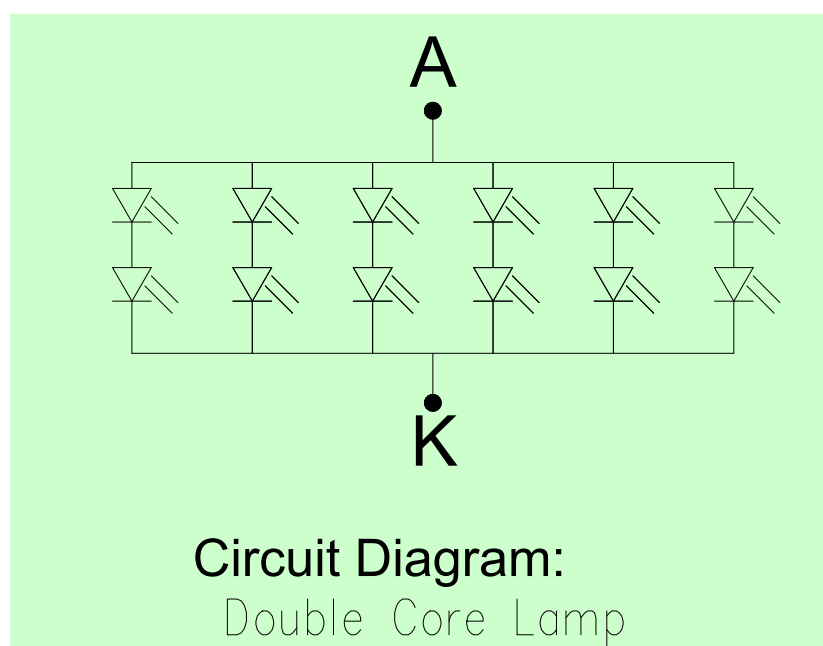

6. Optical Characteristics

6.1. Optical Characteristics

Ta=25°C, VCI=3.3V

| | Item | Symbol | Condition | Specification | | | Unit | |
|----------------------------------|---|----------------|--|---------------|-------|-------|-------------------|--|
| | | | | Min. | Typ. | Max. | | |
| Backlight On (Transmissive Mode) | Luminance on TFT($I_f=20\text{mA/LED}$) | Lv | Normally viewing angle $\theta_x = \phi_y = 0^\circ$ | 560 | 700 | - | cd/m ² | |
| | Contrast ratio(See 6.3) | CR | | 700 | 900 | - | | |
| | Response time (See 6.2) | TR+TF | | - | 30 | 40 | ms | |
| | Chromaticity Transmissive (See 6.5) | Red | X _R | Center CR≥10 | 0.591 | 0.641 | 0.691 | |
| | | | Y _R | | 0.295 | 0.345 | 0.395 | |
| | | Green | X _G | | 0.259 | 0.309 | 0.359 | |
| | | | Y _G | | 0.604 | 0.654 | 0.704 | |
| | | Blue | X _B | | 0.092 | 0.142 | 0.192 | |
| | | | Y _B | | 0.046 | 0.096 | 0.146 | |
| | White | X _W | 0.263 | 0.313 | 0.363 | | | |
| Y _W | | 0.342 | 0.392 | 0.442 | | | | |
| Viewing Angle (See 6.4) | Horizontal | θ_{x+} | - | 80 | - | Deg. | | |
| | | θ_{x-} | - | 80 | - | | | |
| | Vertical | ϕ_{y+} | - | 80 | - | | | |
| | | ϕ_{y-} | - | 80 | - | | | |
| NTSC Ratio(Gamut) | | | | - | 70 | - | % | |

6.2. Definition of Response Time

6.2.1. Normally Black Type (Negative)

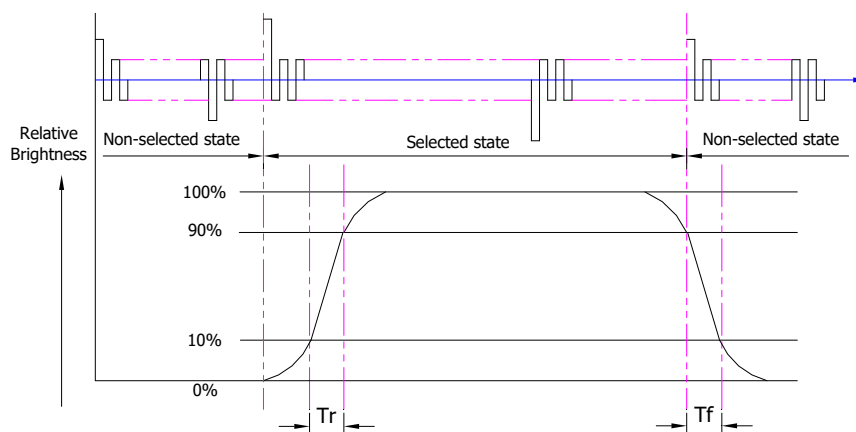

Tr is the time it takes to change from non-selected stage with relative luminance 10% to selected state with relative luminance 90%;

Tf is the time it takes to change from selected state with relative luminance 90% to non-selected state with relative luminance 10%.

Note: Measuring machine: LCD-5100

6.2.2. Normally White Type (Positive)

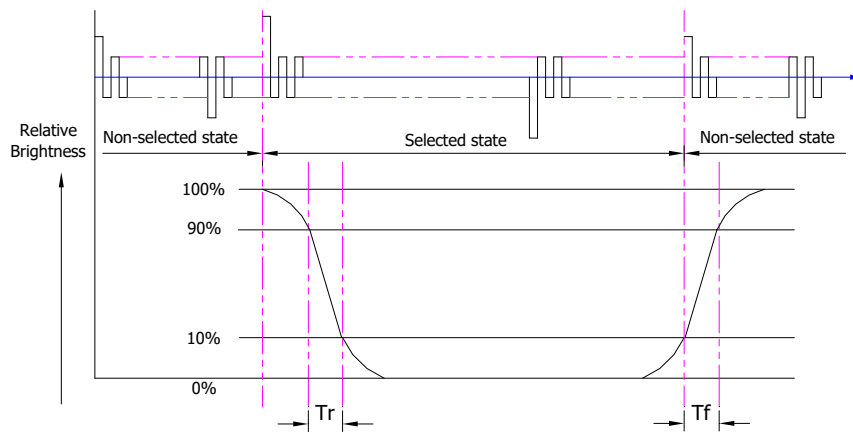

Tr is the time it takes to change from non-selected stage with relative luminance 90% to selected state with relative luminance 10%;

Tf is the time it takes to change from selected state with relative luminance 10% to non-selected state with relative luminance 90%;

Note: Measuring machine: LCD-5100 or EQUI

6.3. Definition of Contrast Ratio

Contrast is measured perpendicular to display surface in reflective and transmissive mode.

The measurement condition is:

| Measuring Equipment | Eldim or Equivalent |
|--------------------------|--------------------------|
| Measuring Point Diameter | 3mm//1mm |
| Measuring Point Location | Active Area centre point |
| Test pattern | A: All Pixels white |
| | B: All Pixel black |
| Contrast setting | Maximum |

Definitions: CR (Contrast) = Luminance of White Pixel / Luminance of Black Pixel

6.4. Definition of Viewing Angles

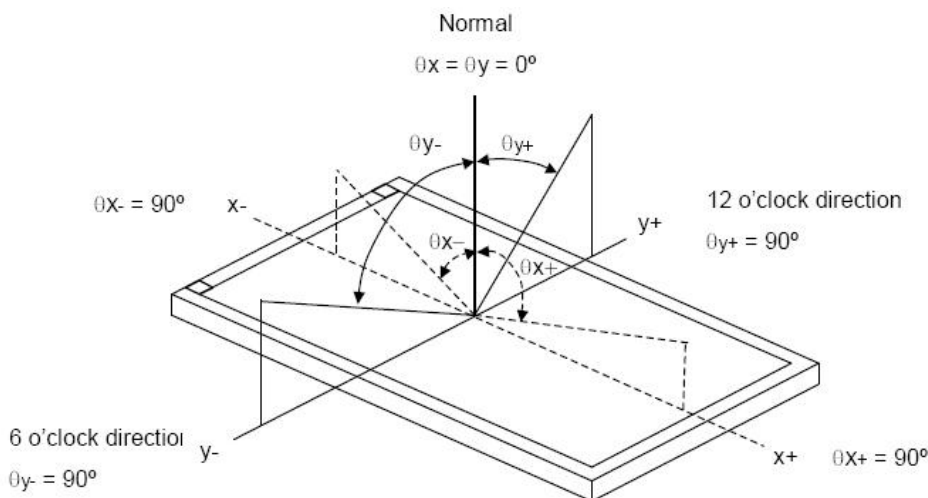

Measuring machine: LCD-5100 or EQUI

6.5. Definition of Color Appearance

R,G,B and W are defined by (x, y) on the IE chromaticity diagram

NTSC=area of RGB triangle/area of NTSC triangleX100%

Measuring picture: Red, Green, Blue and White (Measuring machine: BM-7)

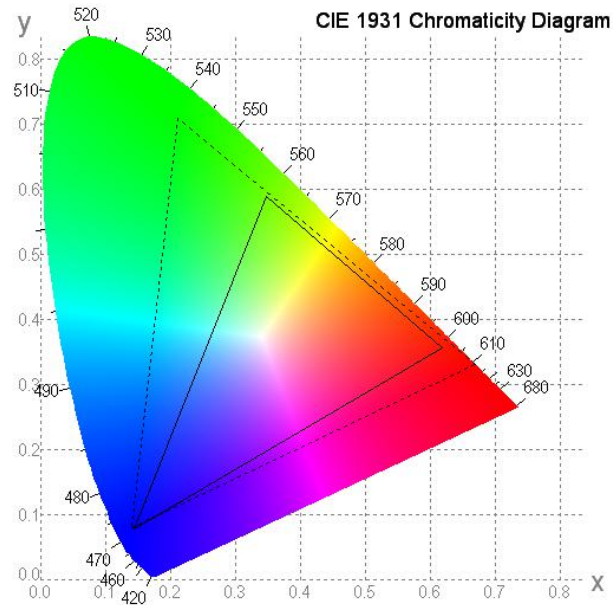

6.6. Definition of Surface Luminance, Uniformity and Transmittance

Using the transmissive mode measurement approach, measure the white screen luminance of the display panel and backlight.

6.6.1. Surface Luminance: $L_V = \text{average} (L_{P1}:L_{P9})$

6.6.2. Uniformity = $\text{Minimal} (L_{P1}:L_{P9}) / \text{Maximal} (L_{P1}:L_{P9}) * 100\%$

6.6.3. Transmittance = $L_V \text{ on LCD} / L_V \text{ on Backlight} * 100\%$

Note: Measuring machine: BM-7

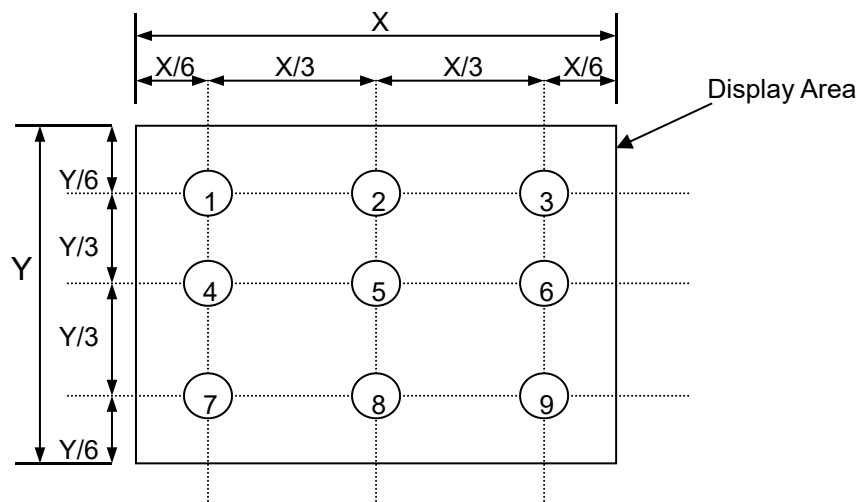

7. Block Diagram and Power Supply

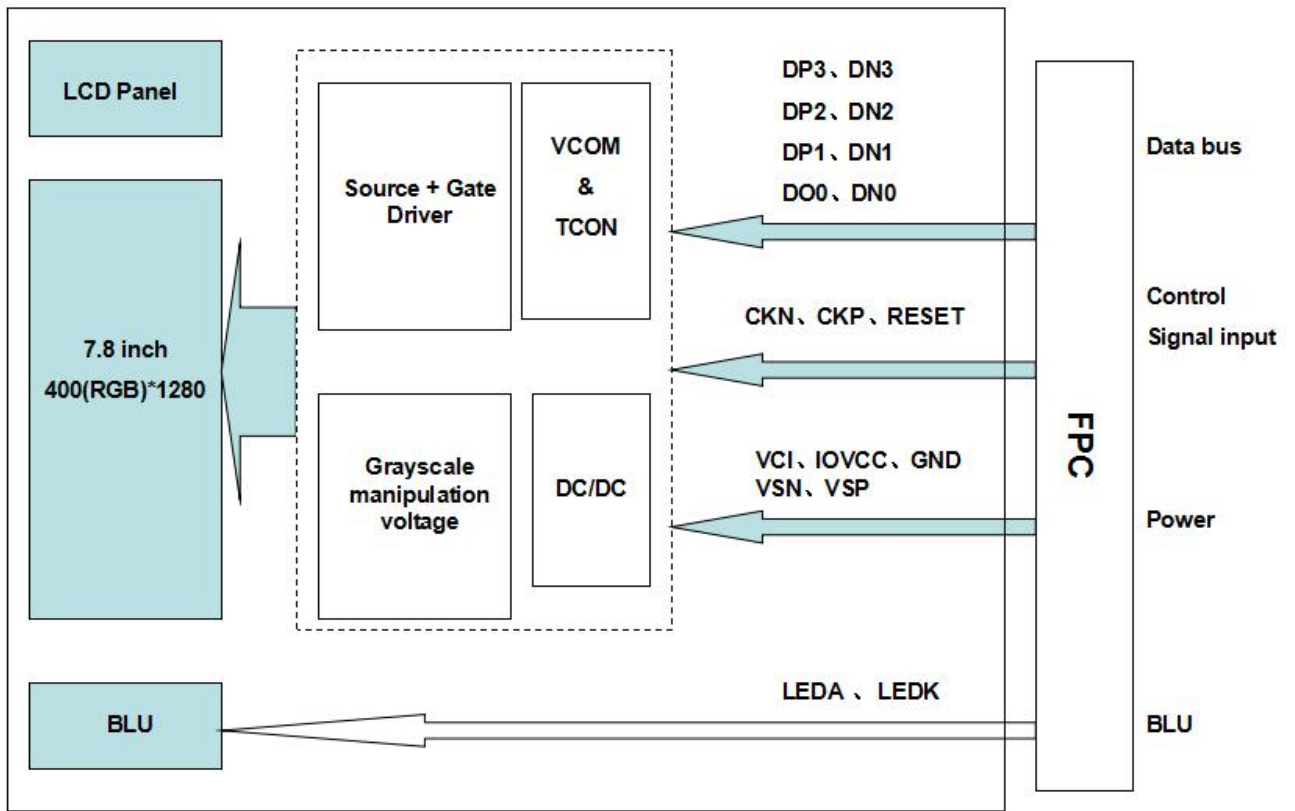

8. Interface Pins Definition

| No. | Symbol | Function | Remark |
|-----|--------|--|--------|
| 1 | GND | Ground | |
| 2 | VCI | A power supply for DC/DC circuit | |
| 3 | VCI | A power supply for DC/DC circuit | |
| 4 | IOVCC | A power supply for the I/O circuit | |
| 5 | GND | Ground | |
| 6 | RESET | Reset pin | |
| 7 | TE | No connection | |
| 8 | GND | Ground | |
| 9 | GND | Ground | |
| 10 | DN3 | MIPI data Input | |
| 11 | DP3 | MIPI data Input | |
| 12 | GND | Ground | |
| 13 | DN2 | MIPI data Input | |
| 14 | DP2 | MIPI data Input | |
| 15 | GND | Ground | |
| 16 | CKN | MIPI clock Input | |
| 17 | CKP | MIPI clock Input | |
| 18 | GND | Ground | |
| 19 | DN1 | MIPI data Input | |
| 20 | DP1 | MIPI data Input | |
| 21 | GND | Ground | |
| 22 | DN0 | MIPI data Input | |
| 23 | DP0 | MIPI data Input | |
| 24 | GND | Ground | |
| 25 | VSP | Input voltage from the set-up circuit (4.5V to 6.0V) | |
| 26 | VSN | Input voltage from the set-up circuit (-4.5V to -6.0V) | |
| 27 | LEDK | Led cathode | |
| 28 | LEDK | Led cathode | |
| 29 | LEDA | Led anode | |
| 30 | LEDA | Led anode | |

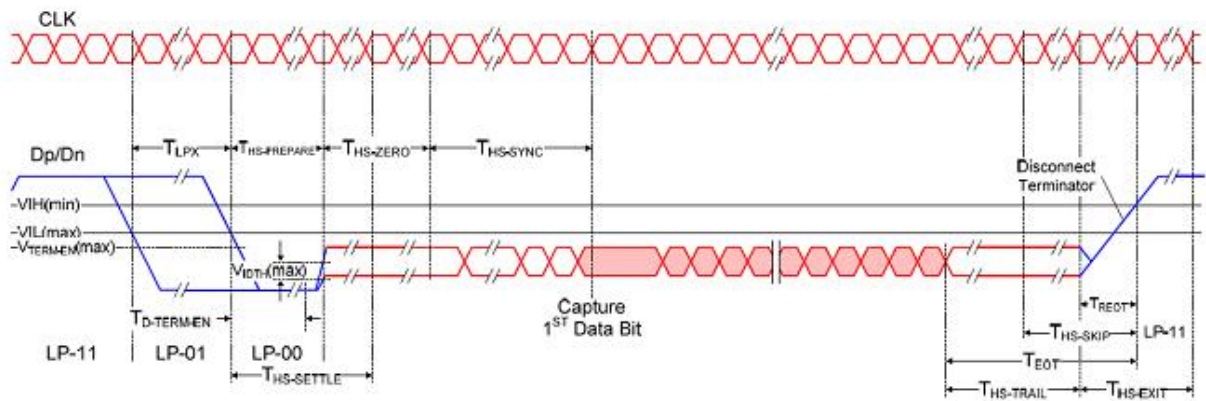

Timing of high-speed data transmission in bursts

| Parameter | Descript | Spec. | | | Unit |
|-------------------|--|--------------------------------------|------|--------------------------|------|
| | | Min. | Typ. | Max. | |
| T_{REOT} | 30%-85% rise time and fall time | - | - | 35 | ns |
| $T_{CLK-MISS}$ | Timeout for receiver to detect absence of Clock transitions and disable the Clock Lane HS-RX. | - | - | 60 | ns |
| $T_{CLK-POST}^*1$ | Time that the transmitter continues to send HS clock after the last associated Data Lane has transitioned to LP Mode. Interval is defined as the period from the end of $T_{HS-TRAIL}$ to the beginning of $T_{CLK-TRAIL}$. | $60\text{ ns} + 52^*UI$ (For DCS) | - | | ns |
| $T_{CLK-PRE}$ | Time that the HS clock shall be driven by the transmitter prior to any associated Data Lane beginning the transition from LP to HS mode. | 8 | - | | ns |
| $T_{CLK-SETTLE}$ | Time interval during which the HS receiver shall ignore any Clock Lane HS transitions, starting from the beginning of $T_{CLK-PRE}$. | 95 | - | 300 | ns |
| $T_{CLK-TERM-EN}$ | Time for the Clock Lane receiver to enable the HS line termination, starting from the time point when Dn crosses V_{ILMAX} . | Time for Dn to reach $V_{TERM-EN}$ | - | 38 | ns |
| $T_{HS-SETTLE}$ | Time interval during which the HS receiver shall ignore any Data Lane HS transitions, starting from the beginning of $T_{HS-PREPARE}$. | $85\text{ ns} + 6^*UI$ | - | $145\text{ ns} + 10^*UI$ | ns |
| T_{EOT} | Time from start of $T_{HS-TRAIL}$ or $T_{CLK-TRAIL}$ period to start of LP-11 state | - | - | $105\text{ns}+48^*UI$ | - |

| | | | | | |
|--------------------------------|---|-----------------|---|-------------|----|
| $T_{HS-EXIT}^{(1)}$ | time to drive LP-11 after HS burst | 100 | - | - | ns |
| $T_{HS-PREPARE}$ | Time to drive LP-00 to prepare for HS transmission | $40ns + 4*UI$ | - | $85ns+6*UI$ | ns |
| $T_{HS-PREPARE} + T_{HS-ZERO}$ | $T_{HS-PREPARE}$ + Time to drive HS-0 before the Sync sequence | $145ns + 10*UI$ | - | - | ns |
| $T_{HS-SKIP}$ | Time-out at RX to ignore transition period of EoT | 40 | - | $55ns+4*UI$ | ns |
| $T_{HS-TRAIL}$ | Time to drive flipped differential state after last payload data bit of a HS transmission burst | $60 + 4*UI$ | - | - | ns |
| T_{LPX} | Length of any Low-Power state period | 50 | - | - | ns |
| Ratio T_{LPX} | Ratio of $T_{LPX(MASTER)}/T_{LPX(SLAVE)}$ between Master and Slave side | 2/3 | - | 3/2 | - |
| T_{TA-GET} | Time to drive LP-00 by new TX | $5*T_{LPX}$ | | | ns |
| T_{TA-GO} | Time to drive LP-00 after Turnaround Request | $4*T_{LPX}$ | | | ns |
| $T_{TA-SURE}$ | Time-out before new TX side starts driving | T_{LPX} | - | $2*T_{LPX}$ | ns |

Note: (1) For image transmission:

$T_{CLK-POSTmin}$ value =164 when MIPI max frequency per lane = 0.53Gbps.

$T_{CLK-POSTmin}$ value =112 when MIPI max frequency per lane = 1Gbps

10. Reset timing

When RESETB of the reset pin equals to Low, it will be in the condition of reset.
When it is in the condition of reset, it will make the device recover the initial set.

However, in order to avoid the reset noise cause reset, there is a mechanism to judge about whether the reset is needed or not.

The closed interval of Low can be shown as the following.

(Test condition: VDDIO=1.65V~3.6V, VSS=0V, $T_A=-20 \sim +85$)

| Parameter | Symbol | Conditions | Spec. | | | Unit |
|-----------------------|--------|------------|-------|------|-----|---------|
| | | | Min. | Typ. | Max | |
| Reset low pulse width | Trst | | 20 | - | - | μs |

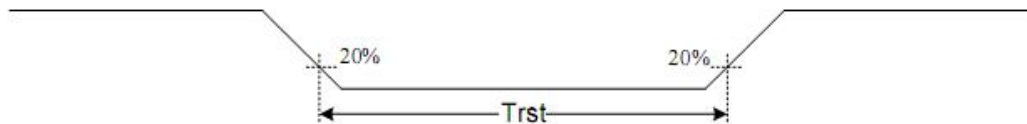

11. Quality Assurance

11.1. Purpose

This standard for Quality Assurance assures the quality of LCD module products supplied to customer.

11.2. Standard for Quality Test

- 11.2.1. Sampling Plan:
GB2828.1-2012
Single sampling, general inspection level II
- 11.2.2. Sampling Criteria:
Visual inspection: AQL 1.5
Electrical functional: AQL 0.65.
- 11.2.3. Reliability Test:
Detailed requirement refer to Reliability Test Specification.

11.3. Nonconforming Analysis & Disposition

- 11.3.1. Nonconforming analysis:
 - 11.3.1.1. Customer should provide overall information of non-conforming sample for their complaints.
 - 11.3.1.2. After receipt of detailed information from customer, the analysis of nonconforming parts usually should be finished in one week.
 - 11.3.1.3. If cannot finish the analysis on time, customer will be notified with the progress status.
- 11.3.2. Disposition of nonconforming:
 - 11.3.2.1. Non-conforming product over PPM level will be replaced.
 - 11.3.2.2. The cause of non-conformance will be analyzed. Corrective action will be discussed and implemented.

11.4. Agreement Items

Shall negotiate with customer if the following situation occurs:

- 11.4.1. There is any discrepancy in standard of quality assurance.
- 11.4.2. Additional requirement to be added in product specification.
- 11.4.3. Any other special problem.

11.5. Standard of the Product Visual Inspection

- 11.5.1. Appearance inspection:
 - 11.5.1.1. The inspection must be under illumination about 1000 – 1500 lx, and the distance of view must be at 30cm ± 2cm.
 - 11.5.1.2. The viewing angle should be 45° from the vertical line without reflection light or follows customer's viewing angle specifications.

11.5.1.3. Definition of area: A Zone: Active Area, B Zone: Viewing Area,

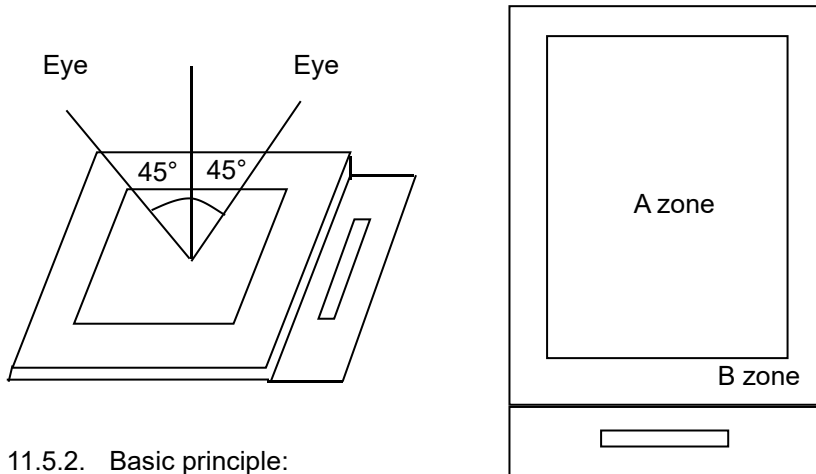

11.5.2. Basic principle:

11.5.2.1. A set of sample to indicate the limit of acceptable quality level must be discussed by both us and customer when there is any dispute happened.

11.5.2.2. New item must be added on time when it is necessary.

11.6. Inspection Specification

| No. | Item | Criteria (Unit: mm) | | | | | | | | | | | | | | | | | | | | |
|-------------------------|---|---|--|------|----------|--------------|----------|------------------|-------------------|------------|-------------------------|-----------------|------------|---------------|------------------|------------|------------|--|------|------------------------------------|--|--------|
| 01 | Black / White spot Foreign material (Round type) Pinholes Stain Particles inside cell. (Minor defect) | $\phi = (a + b) / 2$ Distance between 2 defects should more than 3mm apart. | <table border="1"> <thead> <tr> <th>Size</th> <th>Area</th> <th>Acc. Qty</th> </tr> </thead> <tbody> <tr> <td>$\phi \leq 0.20$</td> <td></td> <td>Ignore</td> </tr> <tr> <td>$0.20 < \phi \leq 0.50$</td> <td></td> <td>$N \leq 3$</td> </tr> <tr> <td>$0.50 < \phi$</td> <td></td> <td>0</td> </tr> </tbody> </table> | | Size | Area | Acc. Qty | $\phi \leq 0.20$ | | Ignore | $0.20 < \phi \leq 0.50$ | | $N \leq 3$ | $0.50 < \phi$ | | 0 | | | | | | |
| | | | Size | Area | Acc. Qty | | | | | | | | | | | | | | | | | |
| $\phi \leq 0.20$ | | Ignore | | | | | | | | | | | | | | | | | | | | |
| $0.20 < \phi \leq 0.50$ | | $N \leq 3$ | | | | | | | | | | | | | | | | | | | | |
| $0.50 < \phi$ | | 0 | | | | | | | | | | | | | | | | | | | | |
| 02 | Electrical Defect (Minor defect) | <table border="1"> <thead> <tr> <th></th> <th>Display Area</th> <th>Total</th> <th rowspan="3">Note1</th> </tr> </thead> <tbody> <tr> <td>Bright dot</td> <td>$N \leq 2$</td> <td>$N \leq 2$</td> </tr> <tr> <td>Dark dot</td> <td>$N \leq 4$</td> <td>$N \leq 4$</td> </tr> <tr> <td>Total dot</td> <td>$N \leq 4$</td> <td>$N \leq 4$</td> <td></td> </tr> <tr> <td>Mura</td> <td colspan="2">Not visible through 5% ND filters.</td> <td>Note 2</td> </tr> </tbody> </table> <p>Remark: 1. Bright dot caused by scratch and foreign object accords to item 1.</p> | | | | Display Area | Total | Note1 | Bright dot | $N \leq 2$ | $N \leq 2$ | Dark dot | $N \leq 4$ | $N \leq 4$ | Total dot | $N \leq 4$ | $N \leq 4$ | | Mura | Not visible through 5% ND filters. | | Note 2 |
| | Display Area | Total | Note1 | | | | | | | | | | | | | | | | | | | |
| Bright dot | $N \leq 2$ | $N \leq 2$ | | | | | | | | | | | | | | | | | | | | |
| Dark dot | $N \leq 4$ | $N \leq 4$ | | | | | | | | | | | | | | | | | | | | |
| Total dot | $N \leq 4$ | $N \leq 4$ | | | | | | | | | | | | | | | | | | | | |
| Mura | Not visible through 5% ND filters. | | Note 2 | | | | | | | | | | | | | | | | | | | |

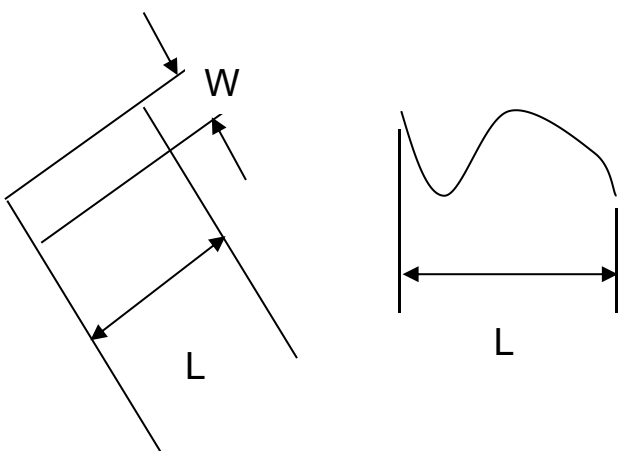
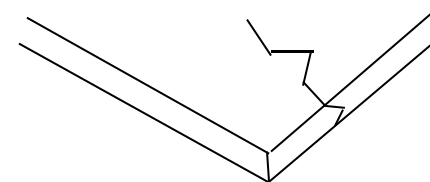
| <p>03</p> | <p>Black and White line Scratch Foreign material (Line type) (Minor defect)</p> |  <table border="1" data-bbox="606 739 1228 1052"> <thead> <tr> <th>Length</th> <th>Width</th> <th>Acc. Qty</th> </tr> </thead> <tbody> <tr> <td>/</td> <td>$W \leq 0.03$</td> <td>Ignore</td> </tr> <tr> <td>$L \leq 2.5$</td> <td>$0.03 < W \leq 0.05$</td> <td>3</td> </tr> <tr> <td>$L \leq 2.5$</td> <td>$0.05 < W \leq 0.10$</td> <td>2</td> </tr> <tr> <td>/</td> <td>$0.1 < W$</td> <td>0</td> </tr> <tr> <td colspan="2">Total</td> <td>3</td> </tr> </tbody> </table> <p>Distance between 2 defects should more than 3mm apart. Scratches not viewable through the back of the display are acceptable.</p> | Length | Width | Acc. Qty | / | $W \leq 0.03$ | Ignore | $L \leq 2.5$ | $0.03 < W \leq 0.05$ | 3 | $L \leq 2.5$ | $0.05 < W \leq 0.10$ | 2 | / | $0.1 < W$ | 0 | Total | | 3 |
|--------------|---|--|--------|-------|----------|---|---------------|--------|--------------|----------------------|---|--------------|----------------------|---|---|-----------|---|-------|--|---|
| Length | Width | Acc. Qty | | | | | | | | | | | | | | | | | | |
| / | $W \leq 0.03$ | Ignore | | | | | | | | | | | | | | | | | | |
| $L \leq 2.5$ | $0.03 < W \leq 0.05$ | 3 | | | | | | | | | | | | | | | | | | |
| $L \leq 2.5$ | $0.05 < W \leq 0.10$ | 2 | | | | | | | | | | | | | | | | | | |
| / | $0.1 < W$ | 0 | | | | | | | | | | | | | | | | | | |
| Total | | 3 | | | | | | | | | | | | | | | | | | |
| <p>04</p> | <p>Glass Crack (Minor defect)</p> |  <p>Crack is potential to enlarge, any type is not allowed.</p> | | | | | | | | | | | | | | | | | | |

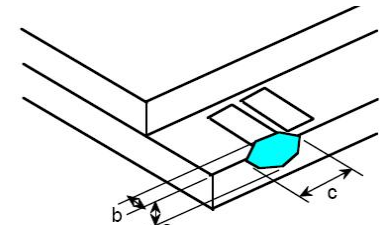
| <p>05</p> | <p>Glass Chipping Pad Area: (Minor defect)</p>  | <table border="1" data-bbox="845 1680 1324 1859"> <thead> <tr> <th>Length and Width</th> <th>Acc. Qty</th> </tr> </thead> <tbody> <tr> <td>$c > 3.0, b < 1.0$</td> <td>1</td> </tr> <tr> <td>$c < 3.0, b < 1.0$</td> <td>3</td> </tr> <tr> <td colspan="2">$a < \text{Glass Thickness}$</td> </tr> </tbody> </table> | Length and Width | Acc. Qty | $c > 3.0, b < 1.0$ | 1 | $c < 3.0, b < 1.0$ | 3 | $a < \text{Glass Thickness}$ | |
|------------------------------|--|--|------------------|----------|--------------------|---|--------------------|---|------------------------------|--|
| Length and Width | Acc. Qty | | | | | | | | | |
| $c > 3.0, b < 1.0$ | 1 | | | | | | | | | |
| $c < 3.0, b < 1.0$ | 3 | | | | | | | | | |
| $a < \text{Glass Thickness}$ | | | | | | | | | | |

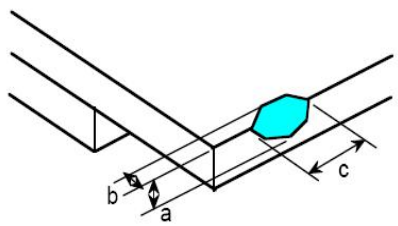
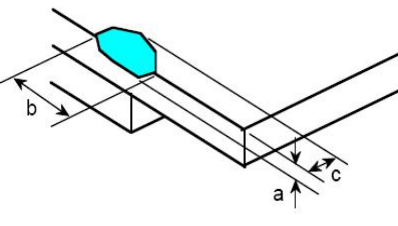
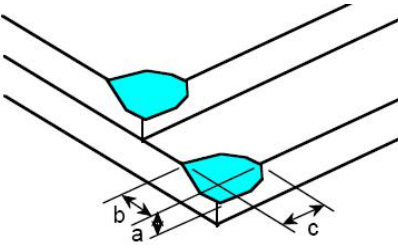
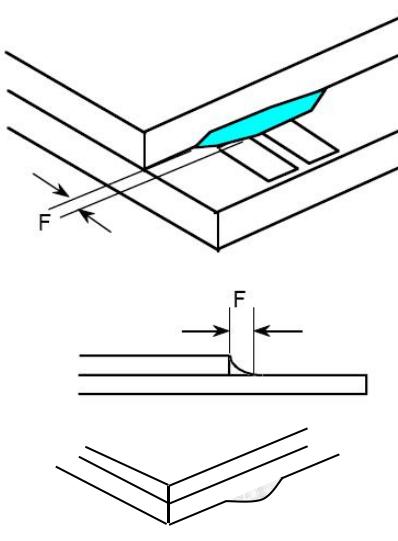
| <p>06</p> | <p>Glass Chipping Rear of Pad Area: (Minor defect)</p>  | <table border="1"> <thead> <tr> <th>Length and Width</th> <th>Acc. Qty</th> </tr> </thead> <tbody> <tr> <td>$c > 3.0, b < 1.0$</td> <td>1</td> </tr> <tr> <td>$c < 3.0, b < 1.0$</td> <td>2</td> </tr> <tr> <td>$c < 3.0, b < 0.5$</td> <td>4</td> </tr> <tr> <td colspan="2">$a < \text{Glass Thickness}$</td> </tr> </tbody> </table> | Length and Width | Acc. Qty | $c > 3.0, b < 1.0$ | 1 | $c < 3.0, b < 1.0$ | 2 | $c < 3.0, b < 0.5$ | 4 | $a < \text{Glass Thickness}$ | |
|------------------------------|--|--|------------------|----------|--------------------|--------|------------------------------|---|--------------------|---|------------------------------|--|
| Length and Width | Acc. Qty | | | | | | | | | | | |
| $c > 3.0, b < 1.0$ | 1 | | | | | | | | | | | |
| $c < 3.0, b < 1.0$ | 2 | | | | | | | | | | | |
| $c < 3.0, b < 0.5$ | 4 | | | | | | | | | | | |
| $a < \text{Glass Thickness}$ | | | | | | | | | | | | |
| <p>07</p> | <p>Glass Chipping Except Pad Area: (Minor defect)</p>  | <table border="1"> <thead> <tr> <th>Length and Width</th> <th>Acc. Qty</th> </tr> </thead> <tbody> <tr> <td>$c > 3.0, b < 1.0$</td> <td>1</td> </tr> <tr> <td>$c < 3.0, b < 1.0$</td> <td>2</td> </tr> <tr> <td>$c < 3.0, b < 0.5$</td> <td>4</td> </tr> <tr> <td colspan="2">$a < \text{Glass Thickness}$</td> </tr> </tbody> </table> | Length and Width | Acc. Qty | $c > 3.0, b < 1.0$ | 1 | $c < 3.0, b < 1.0$ | 2 | $c < 3.0, b < 0.5$ | 4 | $a < \text{Glass Thickness}$ | |
| Length and Width | Acc. Qty | | | | | | | | | | | |
| $c > 3.0, b < 1.0$ | 1 | | | | | | | | | | | |
| $c < 3.0, b < 1.0$ | 2 | | | | | | | | | | | |
| $c < 3.0, b < 0.5$ | 4 | | | | | | | | | | | |
| $a < \text{Glass Thickness}$ | | | | | | | | | | | | |
| <p>08</p> | <p>Glass Corner Chipping: (Minor defect)</p>  | <table border="1"> <thead> <tr> <th>Length and Width</th> <th>Acc. Qty</th> </tr> </thead> <tbody> <tr> <td>$c < 3.0, b < 3.0$</td> <td>Ignore</td> </tr> <tr> <td colspan="2">$a < \text{Glass Thickness}$</td> </tr> </tbody> </table> | Length and Width | Acc. Qty | $c < 3.0, b < 3.0$ | Ignore | $a < \text{Glass Thickness}$ | | | | | |
| Length and Width | Acc. Qty | | | | | | | | | | | |
| $c < 3.0, b < 3.0$ | Ignore | | | | | | | | | | | |
| $a < \text{Glass Thickness}$ | | | | | | | | | | | | |
| <p>09</p> | <p>Glass Burr: (Minor defect)</p>  | <table border="1"> <thead> <tr> <th>Length</th> <th>Acc. Qty</th> </tr> </thead> <tbody> <tr> <td>$F < 1.0$</td> <td>Ignore</td> </tr> </tbody> </table> <p>Glass burr don't affect assemble and module dimension.</p> | Length | Acc. Qty | $F < 1.0$ | Ignore | | | | | | |
| Length | Acc. Qty | | | | | | | | | | | |
| $F < 1.0$ | Ignore | | | | | | | | | | | |

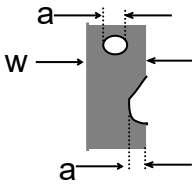
| 10 | <p>FPC Defect: (Minor defect)</p>  | <p>10.1 Dent, pinhole width $a < w/3$. (w: circuitry width.) 10.2 Open circuit is unacceptable. 10.3 No oxidation, contamination and distortion.</p> | | | | | | | | | | |
|----------------------------|---|--|----------|----------|---------------------|--------|----------------------------|---|----------------------------|---|------------------|------|
| 11 | Bubble on Polarizer (Minor defect) | <table border="1" data-bbox="730 595 1198 808"> <thead> <tr> <th>Diameter</th> <th>Acc. Qty</th> </tr> </thead> <tbody> <tr> <td>$\varphi \leq 0.20$</td> <td>Ignore</td> </tr> <tr> <td>$0.20 < \varphi \leq 0.30$</td> <td>4</td> </tr> <tr> <td>$0.30 < \varphi \leq 0.50$</td> <td>1</td> </tr> <tr> <td>$0.50 < \varphi$</td> <td>None</td> </tr> </tbody> </table> | Diameter | Acc. Qty | $\varphi \leq 0.20$ | Ignore | $0.20 < \varphi \leq 0.30$ | 4 | $0.30 < \varphi \leq 0.50$ | 1 | $0.50 < \varphi$ | None |
| Diameter | Acc. Qty | | | | | | | | | | | |
| $\varphi \leq 0.20$ | Ignore | | | | | | | | | | | |
| $0.20 < \varphi \leq 0.30$ | 4 | | | | | | | | | | | |
| $0.30 < \varphi \leq 0.50$ | 1 | | | | | | | | | | | |
| $0.50 < \varphi$ | None | | | | | | | | | | | |
| 12 | Dent on Polarizer (Minor defect) | <table border="1" data-bbox="730 871 1198 1084"> <thead> <tr> <th>Diameter</th> <th>Acc. Qty</th> </tr> </thead> <tbody> <tr> <td>$\varphi \leq 0.20$</td> <td>Ignore</td> </tr> <tr> <td>$0.20 < \varphi \leq 0.30$</td> <td>4</td> </tr> <tr> <td>$0.30 < \varphi \leq 0.50$</td> <td>1</td> </tr> <tr> <td>$0.50 < \varphi$</td> <td>None</td> </tr> </tbody> </table> | Diameter | Acc. Qty | $\varphi \leq 0.20$ | Ignore | $0.20 < \varphi \leq 0.30$ | 4 | $0.30 < \varphi \leq 0.50$ | 1 | $0.50 < \varphi$ | None |
| Diameter | Acc. Qty | | | | | | | | | | | |
| $\varphi \leq 0.20$ | Ignore | | | | | | | | | | | |
| $0.20 < \varphi \leq 0.30$ | 4 | | | | | | | | | | | |
| $0.30 < \varphi \leq 0.50$ | 1 | | | | | | | | | | | |
| $0.50 < \varphi$ | None | | | | | | | | | | | |
| 13 | Bezel | <p>13.1 No rust, distortion on the Bezel. 13.2 No visible fingerprints, stains or other contamination.</p> | | | | | | | | | | |
| 14 | PCB | <p>14.1 No distortion or contamination on PCB terminals. 14.2 All components on PCB must same as documented on the BOM/component layout. 14.3 Follow IPC-A-600F.</p> | | | | | | | | | | |
| 15 | Soldering | Follow IPC-A-610C standard | | | | | | | | | | |
| 16 | Electrical Defect (Major defect) | <p>The below defects must be rejected. 16.1 Missing vertical / horizontal segment, 16.2 Abnormal Display. 16.3 No function or no display. 16.4 Current exceeds product specifications. 16.5 LCD viewing angle defect. 16.6 No Backlight. 16.7 Dark Backlight. 16.8 Touch Panel no function.</p> | | | | | | | | | | |

Remark: LCD Panel Broken shall be rejected. Defect out of LCD viewing area is acceptable.

11.7. Classification of Defects

- 11.7.1. Visual defects (Except no / wrong label) are treated as minor defect and electrical defect is major.
- 11.7.2. Two minor defects are equal to one major in lot sampling inspection.

11.8. Identification/marketing criteria

Any unit with illegible / wrong /double or no marking/ label shall be rejected.

11.9. Packing

- 11.9.1. There should be no damage of the outside carton box, each packaging box should have one identical label.
- 11.9.2. Modules inside package box should have compliant mark.
- 11.9.3. All direct package materials shall offer ESD protection.

Note1: Bright dot is defined as the defective area of the dot is larger than 50% of one sub-pixel area.

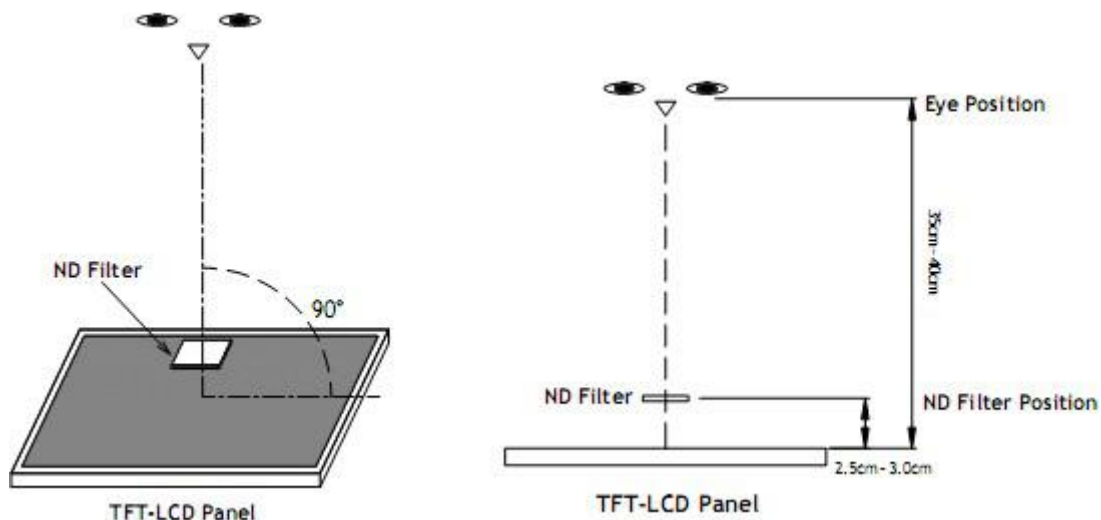

Bright dot: The bright dot size defect at black display pattern. It can be recognized by 2% transparency of filter when the distance between eyes and panel is $350\text{mm} \pm 50\text{mm}$.

Dark dot: Cyan, Magenta or Yellow dot size defect at white display pattern. It can be recognized by 5% transparency of filter when the distance between eyes and panel is $350\text{mm} \pm 50\text{mm}$.

Note2: Mura on display which appears darker / brighter against background brightness on parts of display area.

12. Reliability Specification

| No | Item | Condition | Quantity | Criteria |
|----|-----------------------------|---|----------|------------------|
| 1 | High Temperature Operating | 50°C, 96Hrs | 2 | GB/T2423.2-2008 |
| 2 | Low Temperature Operating | -20°C, 96Hrs | 2 | GB/T2423.1-2008 |
| 3 | High Humidity | 40°C, 90%RH, 96Hrs | 2 | GB/T2423.3-2016 |
| 4 | High Temperature Storage | 80°C, 96Hrs | 2 | GB/T2423.2-2008 |
| 5 | Low Temperature Storage | -30°C, 96Hrs | 2 | GB/T2423.1-2008 |
| 6 | Thermal Cycling Test | -20°C, 60min ~ 50°C, 60min, 20 cycles. | 2 | GB/T2423.22-2012 |
| 7 | Packing vibration | Frequency range:10Hz~50Hz Acceleration of gravity:5G X, Y, Z 30 min for each direction. | 2 | GB/T5170.14-2009 |
| 8 | Electrical Static Discharge | Air: ±4KV 150pF/330 Ω 5 times Contact: ±2KV 150pF/330 Ω 5 times | 2 | GB/T17626.2-2018 |
| 9 | Drop Test (Packaged) | Height:80 cm,1 corner, 3 edges, 6 surfaces. | 2 | GB/T2423.8-1995 |

Note1. No deflection cosmetic and operational function allowable.

Note2. Total current Consumption should be below double of initial value

13. Precautions and Warranty

13.1. Safety

- 13.1.1. The liquid crystal in the LCD is poisonous. Do not put it in your mouth. If the liquid crystal touches your skin or clothes, wash it off immediately using soap and water.
- 13.1.2. Since the liquid crystal cells are made of glass, do not apply strong impact on them. Handle with care.

13.2. Handling

- 13.2.1. Reverse and use within ratings in order to keep performance and prevent damage.
- 13.2.2. Do not wipe the polarizer with dry cloth, as it might cause scratch. If the surface of the LCD needs to be cleaned, wipe it swiftly with cotton or other soft cloth soaked with petroleum IPA, do not use other chemicals.

13.3. Storage

- 13.3.1. Do not store the LCD module beyond the specified temperature ranges.
- 13.3.2. Strong light exposure causes degradation of polarizer and color filter.

13.4. Metal Pin (Apply to Products with Metal Pins)

13.4.1. Pins of LCD and Backlight

13.4.1.1. Solder tip can touch and press on the tip of Pin LEAD during the soldering

13.4.1.2. Recommended Soldering Conditions

Solder Type: Sn96.3~94-Ag3.3~4.3-Cu0.4~1.1

Maximum Solder Temperature: 370°C

Maximum Solder Time: 3s at the maximum temperature

Recommended Soldering Temp: 350±20°C

Typical Soldering Time: ≤3s

13.4.1.3. Solder Wetting

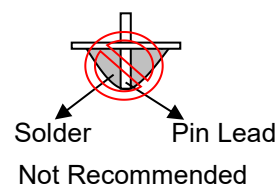
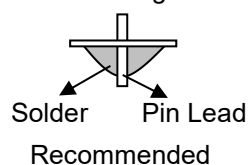

13.4.2. Pins of EL

13.4.2.1. Solder tip can touch and press on the tip of EL leads during soldering.

13.4.2.2. No Solder Paste on the soldering pad on the motherboard is recommended.

13.4.2.3. Recommended Soldering Conditions

Solder type: Nippon Alimit Leadfree SR-34, size 0.5mm

Recommended Solder Temperature: 270~290°C

Typical Soldering Time: ≤2s

Minimum solder distance from EL lamp (body): 2.0mm

13.4.2.4. No horizontal press on the EL leads during soldering.

13.4.2.5. 180° bend EL leads three times is not allowed.

13.4.2.6. Solder Wetting



13.4.2.7. The type of the solder iron:



13.4.2.8. Solder Pad

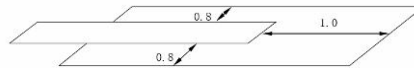

13.5. Operation

- 13.5.1. Do not drive LCD with DC voltage
- 13.5.2. Response time will increase below lower temperature
- 13.5.3. Display may change color with different temperature
- 13.5.4. Mechanical disturbance during operation, such as pressing on the display area, may cause the segments to appear “fractured”.
- 13.5.5. Do not connect or disconnect the LCM to or from the system when power is on.
- 13.5.6. Never use the LCM under abnormal condition of high temperature and high humidity.
- 13.5.7. Module has high frequency circuits. Sufficient suppression to the electromagnetic interface shall be done by system manufacturers. Grounding and shielding methods may be important to minimize the interference.
- 13.5.8. Do not display the fixed pattern for long time (we suggest the time not longer than one hour) because it may develop image sticking due to the TFT structure.

13.6. Static Electricity

- 13.6.1. CMOS LSIs are equipped in this unit, so care must be taken to avoid the electro-static charge, by ground human body, etc.
- 13.6.2. The normal static prevention measures should be observed for work clothes and benches.
- 13.6.3. The module should be kept into anti-static bags or other containers resistant to static for storage.

13.7. Limited Warranty

- 13.7.1. Our warranty liability is limited to repair and/or replacement. We will not be responsible for any consequential loss.
- 13.7.2. If possible, we suggest customer to use up all modules in six months. If the module storage time over twelve months, we suggest that recheck it before the module be used.
- 13.7.3. After the product shipped, any product quality issues must be feedback within three months, otherwise, we will not be responsible for the subsequent or consequential events.

14. Packaging

TBD

15. Outline Drawing

