

PRODUCT SPECIFICATION

4.9" TN TFT LCD MODULE

MODEL: T049364078-A0TMN-001 Ver: 1.1

ROHS

< ◇ > Preliminary Specification

< ◆ > Finally Specification

CUSTOMER'S APPROVAL	
CUSTOMER :	
SIGNATURE:	DATE:

APPROVED BY	PM REVIEWED	PD REVIEWED	PREPARED BY

Revision History

Revision	Date	Originator	Detail	Remarks
Ver 1.0	2018.05.21	ZDT	Initial Release	
1.1	2018.08.03	ZDT	Modify Viewing Angle Modify Outline Drawing(B)	P6 P25

Table of Contents

No.	Item	Page
1.	General Description.....	4
2.	Module Parameter.....	4
3.	Absolute Maximum Ratings.....	4
4.	DC Characteristics.....	5
5.	Backlight Characteristic.....	5
	5.1. Backlight Characteristics.....	5
	5.2. Backlighting circuit.....	5
6.	Optical Characteristics.....	6
	6.1. Optical Characteristics.....	6
	6.2. Definition of Response Time.....	6
	6.3. Definition of Contrast Ratio.....	7
	6.4. Definition of Viewing Angles.....	7
	6.5. Definition of Color Appearance.....	8
	6.6. Definition of Surface Luminance, Uniformity and Transmittance.....	8
7.	Block Diagram and Power Supply.....	9
8.	Interface Pins Definition.....	10
9.	Timing Characteristics.....	12
	9.1. Clock and Data Input Waveforms.....	12
	9.2. Data Input Format.....	12
	9.3. 3-wire Timing Diagram.....	13
	9.4. Input signal characteristics.....	14
10.	Quality Assurance.....	15
	10.1. Purpose.....	15
	10.2. Standard for Quality Test.....	15
	10.3. Nonconforming Analysis & Disposition.....	15
	10.4. Agreement Items.....	15
	10.5. Standard of the Product Visual Inspection.....	15
	10.6. Inspection Specification.....	16
	10.7. Classification of Defects.....	20
	10.8. Identification/marketing criteria.....	20
	10.9. Packing.....	20
11.	Reliability Specification.....	21
12.	Precautions and Warranty.....	22
	12.1. Safety.....	22
	12.2. Handling.....	22
	12.3. Storage.....	22
	12.4. Metal Pin (Apply to Products with Metal Pins).....	22
	12.5. Operation.....	23
	12.6. Static Electricity.....	23
	12.7. Limited Warranty.....	23
13.	Packaging.....	24
14.	Outline Drawing.....	25

1. General Description

The specification is a transmissive type color active matrix liquid crystal display (LCD) which uses amorphous thin film transistor (TFT) as switching devices. This product is composed of a TFT-LCD panel, driver ICs and a backlight unit.

2. Module Parameter

Features	Details	Unit
Display Size(Diagonal)	4.9"	
LCD type	TN TFT	
Display Mode	Transmissive /Normally white	
Resolution	364RGB x 78	Pixels
View Direction	9 O'clock	Best Image
Gray Scale Inversion Direction	3 O'clock	
Module Outline	128.8(H) x 37.25 (V) x 2.7(T) (Note1)	mm
Active Area	123.4(H) x 26.44(V)	mm
Pixel Pitch	339(H) x 339(V)	um
Pixel Arrangement	RGB vertical stripe	
Polarizer Surface Treatment	Anti-Glare	
Display Colors	16M	
Interface	24-bit RGB interface+3-lineSPI	
Driver IC	ILI6480	
With or Without Touch Panel	Without	
Operating Temperature	-20~70	°C
Storage Temperature	-30~80	°C
Weight	TBD	g

Note 1: Exclusive hooks, posts, FFC/FPC tail etc.

3. Absolute Maximum Ratings

$V_{SS}=0V$, $T_a=25^{\circ}C$

Item	Symbol	Min.	Max.	Unit
Supply Voltage	VDD	-0.5	5.0	V
Storage temperature	T _{STG}	-30	+80	°C
Operating temperature	T _{OP}	-20	+70	°C

Note 1: If T_a below $50^{\circ}C$, the maximal humidity is 90%RH, if T_a over $50^{\circ}C$, absolute humidity should be less than 60%RH.

Note 2: The response time will be extremely slow when the operating temperature is around $-10^{\circ}C$, and the back ground will become darker at high temperature operating.

4. DC Characteristics

Item	Symbol	Min.	Typ.	Max.	Unit	
Digital Interface Supply Voltage	VDD	3.0	3.3	3.6	V	
Logic Low input voltage	V _{IL}	GND	-	0.3*VDD	V	
Logic High input voltage	V _{IH}	0.7*VDD	-	VDD	V	
Logic Low output voltage	V _{OL}	GND	-	GND+0.4	V	
Logic High output voltage	V _{OH}	VDD-0.4	-	-	V	
Current Consumption All Black	Logic	I _{CC} + I _{IN}	-	TBD	-	mA
	Analog					

5. Backlight Characteristic

5.1. Backlight Characteristics

Item	Symbol	Condition	Min.	Typ.	Max.	Unit
Forward Voltage	V _F	Ta=25 °C, I _F =20mA/LED	16.8	18.6	20.4	V
Forward Current	I _F	Ta=25 °C, V _F =3.1V/LED	-	60	-	mA
Power dissipation	P _D		-	1116	-	mW
Uniformity	Avg		-	80	-	%
LED working life(25°C)	-		-	30000	-	Hrs
Drive method	Constant current					
LED Configuration	18 White LEDs (6 LEDs in one string and 3 groups in parallel)					

Note: LED life time defined as follows: The final brightness is at 50% of original brightness.
The environmental conducted under ambient air flow, at Ta=25±2 °C,60%RH±5%, I_F=20mA.

5.2. Backlighting circuit

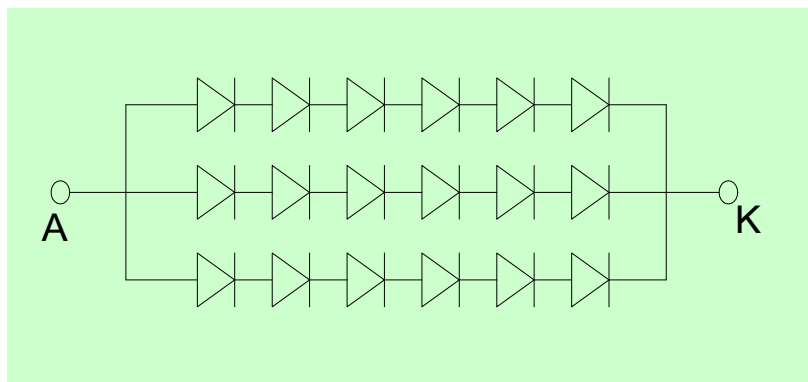

6. Optical Characteristics

6.1. Optical Characteristics

Ta=25°C, $V_{DD}=3.3V$

	Item	Symbol	Condition	Specification			Unit	
				Min.	Typ.	Max.		
Backlight On (Transmissive Mode)	Luminance on TFT($I_f=20mA/LED$)	Lv	Normally viewing angle $\theta_x = \phi_y = 0^\circ$	520	650	-	cd/m ²	
	Contrast ratio(See 6.3)	CR		-	TBD	-		
	Response time (See 6.2)	TR+TF		-	TBD	-	ms	
	Chromaticity Transmissive (See 6.5)	Red	X _R	Center CR≥10	-	TBD	-	
			Y _R		-	TBD	-	
		Green	X _G		-	TBD	-	
			Y _G		-	TBD	-	
		Blue	X _B		-	TBD	-	
			Y _B		-	TBD	-	
	White	X _W	-	TBD	-			
		Y _W	-	TBD	-			
	Viewing Angle (See 6.4)	Horizontal	θ_{x+}	Center CR≥10	-	(60)	-	Deg.
			θ_{x-}		-	(50)	-	
Vertical		ϕ_{y+}	-		(60)	-		
		ϕ_{y-}	-		(60)	-		
	NTSC Ratio(Gamut)			-	53	-	%	

6.2. Definition of Response Time

6.2.1. Normally Black Type (Negative)

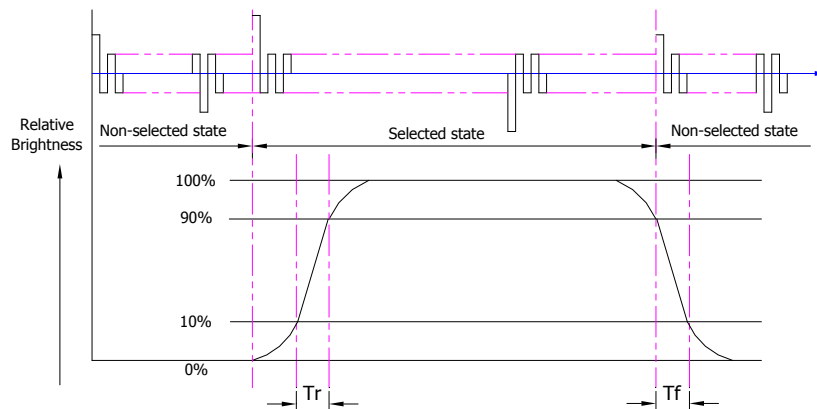

T_r is the time it takes to change from non-selected state with relative luminance 10% to selected state with relative luminance 90%;

T_f is the time it takes to change from selected state with relative luminance 90% to non-selected state with relative luminance 10%.

Note: Measuring machine: LCD-5100

6.2.2. Normally White Type (Positive)

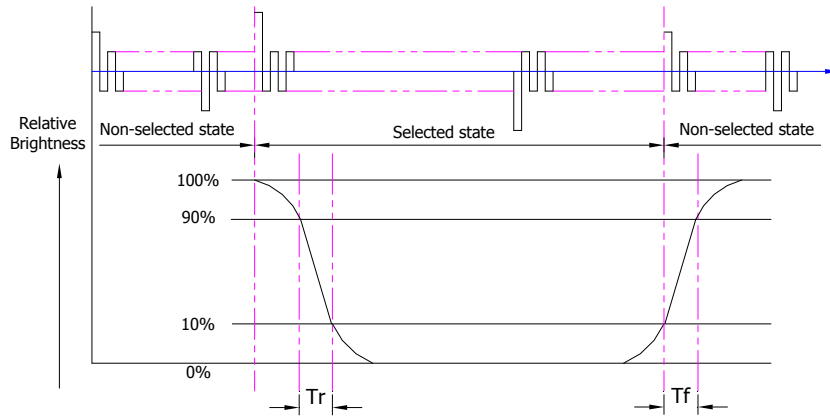

T_r is the time it takes to change from non-selected state with relative luminance 90% to selected state with relative luminance 10%;

T_f is the time it takes to change from selected state with relative luminance 10% to non-selected state with relative luminance 90%;

Note: Measuring machine: LCD-5100 or EQUI

6.3. Definition of Contrast Ratio

Contrast is measured perpendicular to display surface in reflective and transmissive mode.

The measurement condition is:

Measuring Equipment	Eldim or Equivalent
Measuring Point Diameter	3mm//1mm
Measuring Point Location	Active Area centre point
Test pattern	A: All Pixels white
	B: All Pixel black
Contrast setting	Maximum

Definitions: CR (Contrast) = Luminance of White Pixel / Luminance of Black Pixel

6.4. Definition of Viewing Angles

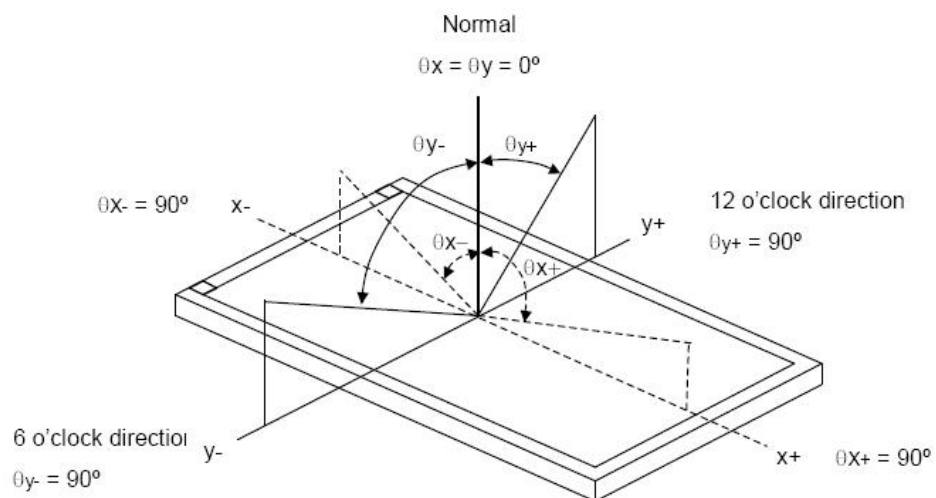

Measuring machine: LCD-5100 or EQUI

6.5. Definition of Color Appearance

R,G,B and W are defined by (x, y) on the IE chromaticity diagram

NTSC=area of RGB triangle/area of NTSC triangleX100%

Measuring picture: Red, Green, Blue and White (Measuring machine: BM-7)

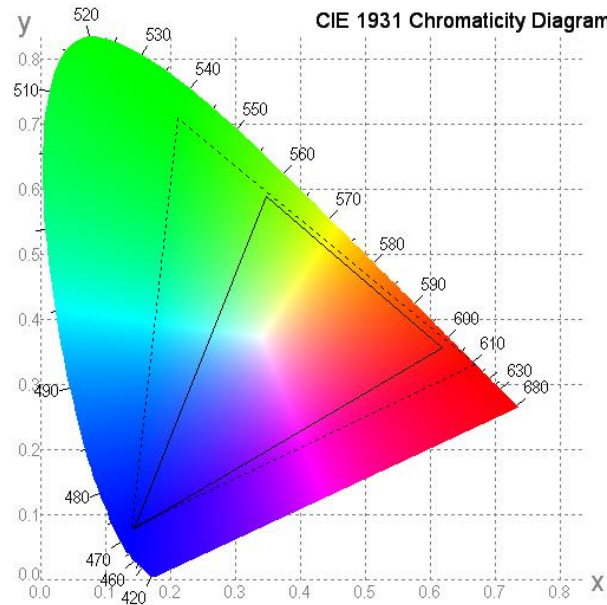

6.6. Definition of Surface Luminance, Uniformity and Transmittance

Using the transmissive mode measurement approach, measure the white screen luminance of the display panel and backlight.

6.6.1. Surface Luminance: $L_V = \text{average} (L_{P1}:L_{P9})$

6.6.2. Uniformity = Minimal ($L_{P1}:L_{P9}$) / Maximal ($L_{P1}:L_{P9}$) * 100%

6.6.3. Transmittance = L_V on LCD / L_V on Backlight * 100%

Note: Measuring machine: BM-7

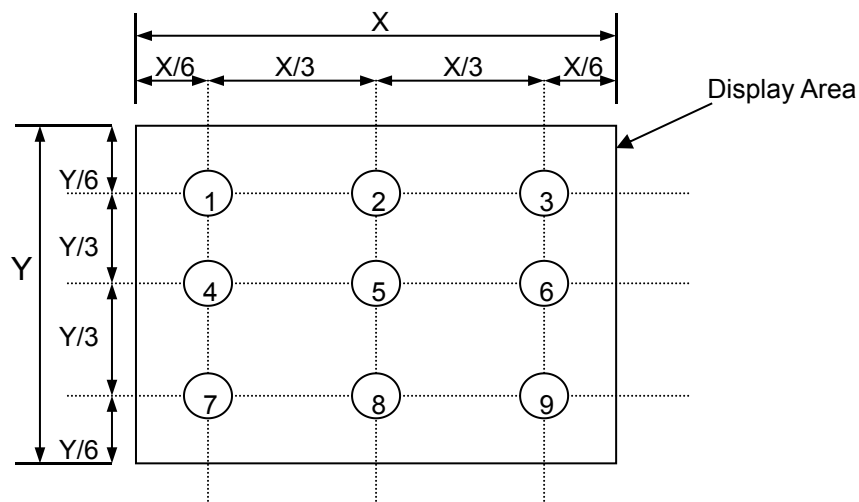

7. Block Diagram and Power Supply

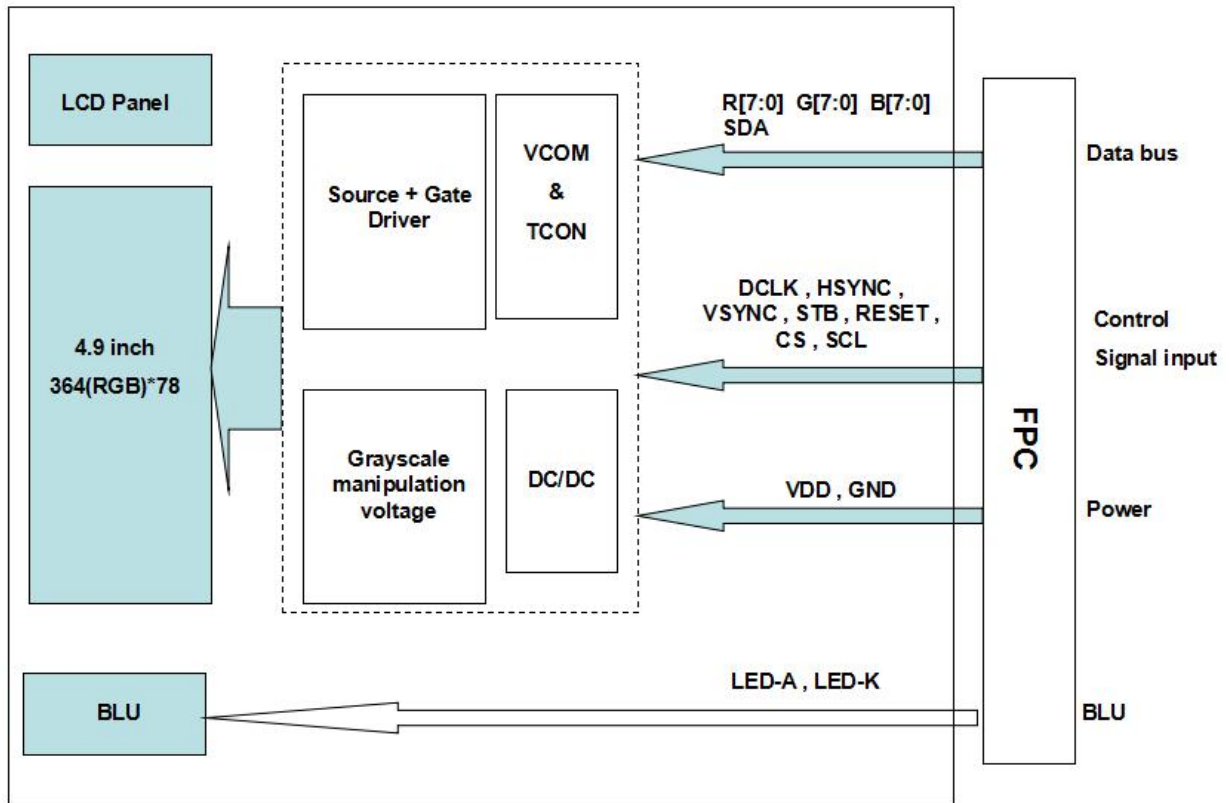

8. Interface Pins Definition

No.	Symbol	Function	Remark
1	GND	Ground	
2	NC(XR)	No connection	
3	NC(YD)	No connection	
4	NC(XL)	No connection	
5	NC(YU)	No connection	
6	VDD	Power supply	
7	VSYNC	Vertical Synchronous Signal	
8	HSYNC	Horizontal Synchronous Signal	
9	DCLK	Clock signal to sample each data	
10	DE	Input data enable control.	
11	CS	Chip select	
12	SDA	SPI Serial Data Input/output	
13	SCL	SPI Serial Clock	
14	STB	Standby setting for testing	
15	RESET	Reset signal, Low active	
16	R0	Red data signal	
17	R1	Red data signal	
18	R2	Red data signal	
19	R3	Red data signal	
20	R4	Red data signal	
21	R5	Red data signal	
22	R6	Red data signal	
23	R7	Red data signal	
24	G0	Green data signal	
25	G1	Green data signal	
26	G2	Green data signal	
27	G3	Green data signal	
28	G4	Green data signal	
29	G5	Green data signal	
30	G6	Green data signal	
31	G7	Green data signal	
32	B0	Blue data signal	
33	B1	Blue data signal	
34	B2	Blue data signal	
35	B3	Blue data signal	
36	B4	Blue data signal	
37	B5	Blue data signal	
38	B6	Blue data signal	
39	B7	Blue data signal	
40	GND	Ground	

41	NC	No connection	
42	LED-K	Backlight Cathode	
43	LED-A	Backlight Anode	
44	NC	No connection	
45	GND	Ground	

9. Timing Characteristics

9.1. Clock and Data Input Waveforms

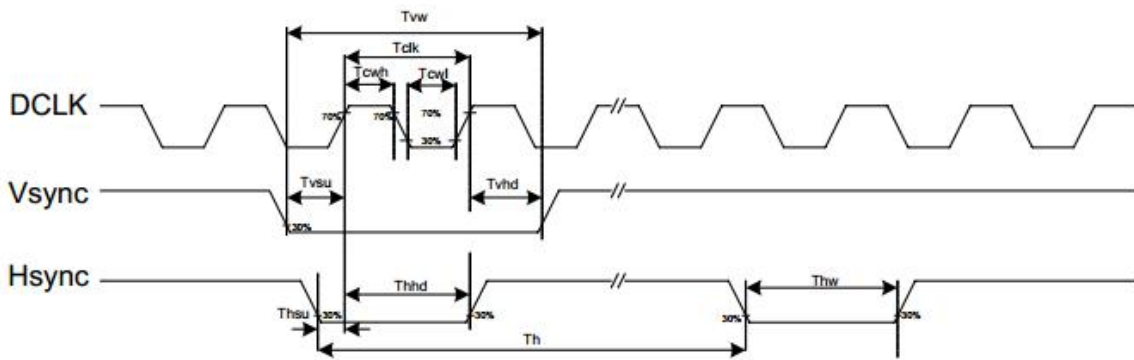
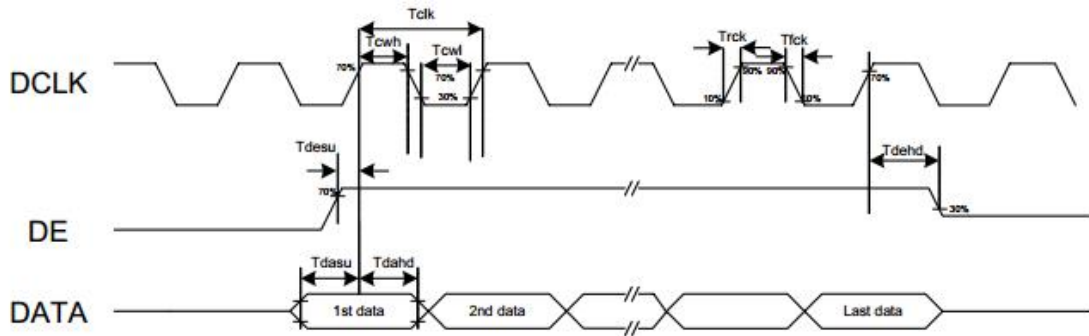

9.2. Data Input Format

Vertical input timing

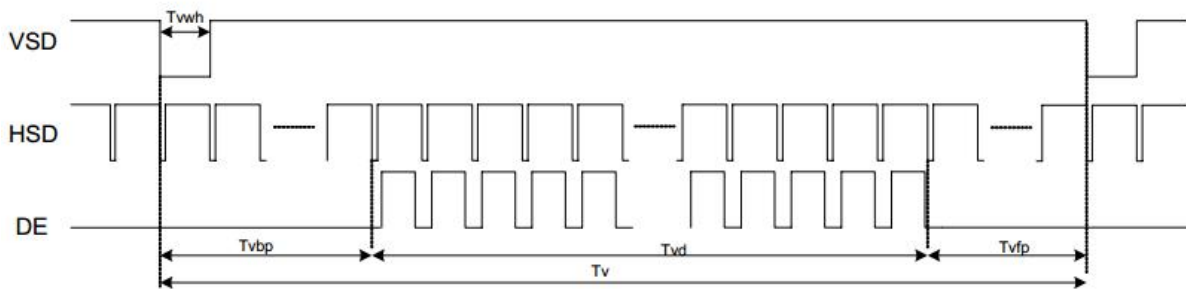

Parallel RGB Mode Data format

(HV Mode)

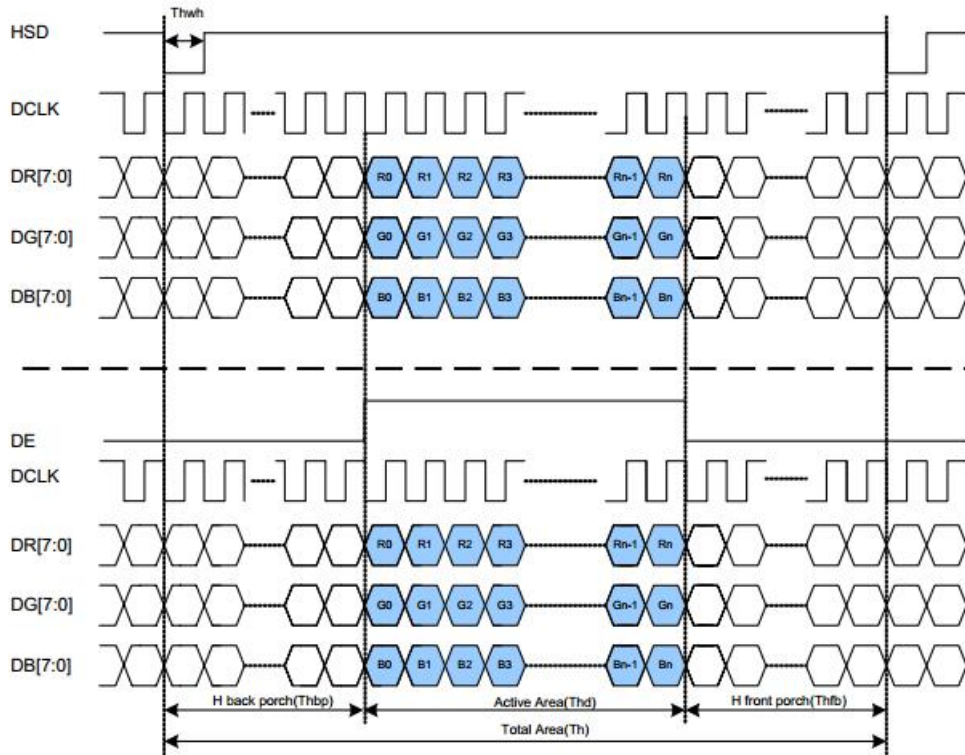

Parallel RGB input timign table

Parameter	Symbol	Value			Unit
		Min.	Typ.	Max.	
DCLK frequency	fclk	5	9	12	MHz
VSD period time	Tv	277	288	400	H
VSD display area	Tvd	272			H
VSD back porch	Tvb	3	8	31	H
VSD front porch	Tvfp	2	8	93	H
HSD period time	Th	520	525	800	DCLK
HSD display area	Thd	480			DCLK
HSD back porch	Thbp	36	40	255	DCLK
HSD front porch	Thfp	4	5	65	DCLK

9.3. 3-wire Timing Diagram

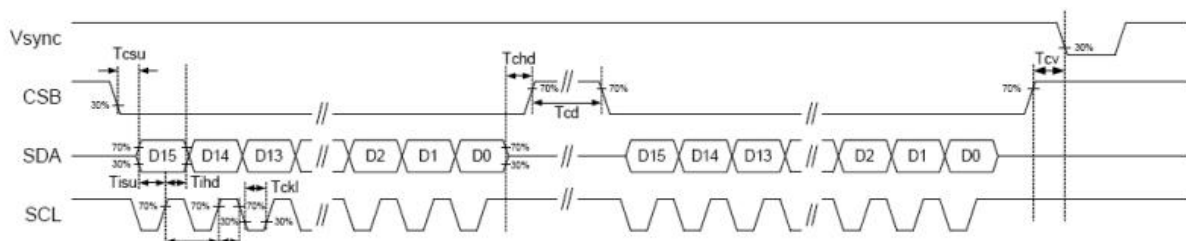

9.4. Input signal characteristics

AC Electrical Characteristics (VDDIO=VDD=3.0 TO 3.6v, GND=0V, TA=-20 to +85 °C)

Parameters	Symbol	Min.	Typ.	Max.	Unit	Conditions
System operation timing						
VDD power source slew time	TPOR	-	-	20	ms	From 0V to 99% VDD
GRB pulse width	tRSTW	10	50	-	us	R=10Kohm, C=1uF
Input Output timing						
DCLK clock time	Tclk	33.3	-	-	ns	DCLK=30MHz
Clock rising time	Trck	9	-	-	ns	
Clock falling time	Tfck	9	-	-	ns	
HSD width	Thwh	1	-	-	DCLK	
HSD period time	Th	55	60	65	us	
HSD setup time	Thst	12	-	-	ns	
HSD hold time	Thhd	12	-	-	ns	
VSD width	Tvwh	1	-	-	Th	
VSD setup time	Tvst	12	-	-	ns	
VSD hold time	Tvhd	12	-	-	ns	
Data setup time	Tdsu	12	-	-	ns	
Data hold time	Tdhd	12	-	-	ns	
DE setup time	Tdesu	12	-	-	ns	
DE hold time	Tdehd	12	-	-	ns	
Source output setting time	Tst	-	-	TBD	us	10% to 90% CL=60pF, RL=2Kohm
Gate output setting time	Tgst	-	500	1000	ns	10% to 90%, CL=60pF
VCOM output setting time	Tcst	-	-	TBD	us	10% to 90%, CL=40nF, RL=50ohm
Time from VSD to 1st line data input	Tvs	3	8	31	Th	HV mode By HDL[4:0] setting
3-wire serial communication AC timing						
Serial clock	Tsck	200	-	-	ns	
SCL pulse duty	Tscdut	40	50	60	%	
Serial data setup time	Tisu	50	-	-	ns	
Serial data hold time	Tihd	50	-	-	ns	
Serial clock high/low	Tssw	50	-	-	ns	
CSB to VSD	Tcv	1			us	
CSB distinguish time	Tcd	400	-	-	ns	
CSB input setup time	Tcsu	50	-	-	ns	
CSB input hold time	Tchd	50	-	-	ns	

10. Quality Assurance

10.1.Purpose

This standard for Quality Assurance assures the quality of LCD module products supplied to customer.

10.2.Standard for Quality Test

10.2.1. Sampling Plan:

GB2828.1-2012

Single sampling, general inspection level II

10.2.2. Sampling Criteria:

Visual inspection: AQL 1.5%

Electrical functional: AQL 0.65%.

10.2.3. Reliability Test:

Detailed requirement refer to Reliability Test Specification.

10.3.Nonconforming Analysis & Disposition

10.3.1. Nonconforming analysis:

10.3.1.1. Customer should provide overall information of non-conforming sample for their complaints.

10.3.1.2. After receipt of detailed information from customer, the analysis of nonconforming parts usually should be finished in one week.

10.3.1.3. If cannot finish the analysis on time, customer will be notified with the progress status.

10.3.2. Disposition of nonconforming:

10.3.2.1. Non-conforming product over PPM level will be replaced.

10.3.2.2. The cause of non-conformance will be analyzed. Corrective action will be discussed and implemented.

10.4.Agreement Items

Shall negotiate with customer if the following situation occurs:

10.4.1. There is any discrepancy in standard of quality assurance.

10.4.2. Additional requirement to be added in product specification.

10.4.3. Any other special problem.

10.5.Standard of the Product Visual Inspection

10.5.1. Appearance inspection:

10.5.1.1. The inspection must be under illumination about 1000 – 1500 lx, and the distance of view must be at 30cm ± 2cm.

10.5.1.2. The viewing angle should be 45° from the vertical line without reflection light or follows customer's viewing angle specifications.

10.5.1.3. Definition of area: A Zone: Active Area, B Zone: Viewing Area,

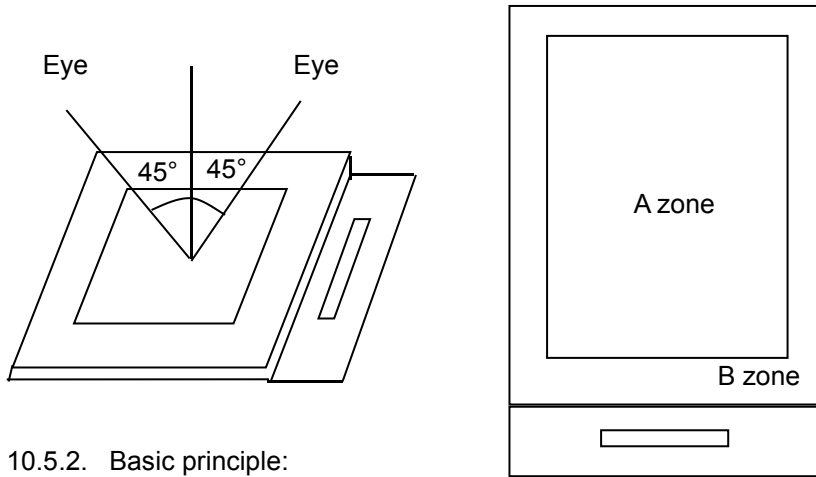

10.5.2. Basic principle:

10.5.2.1. A set of sample to indicate the limit of acceptable quality level must be discussed by both us and customer when there is any dispute happened.

10.5.2.2. New item must be added on time when it is necessary.

10.6. Inspection Specification

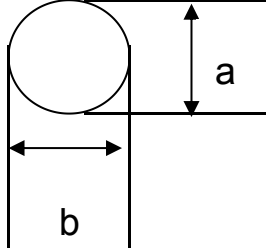
No.	Item	Criteria (Unit: mm)																		
01	Black / White spot Foreign material (Round type) Pinholes Stain Particles inside cell. (Minor defect)	 $\phi = (a + b) / 2$ <table border="1" data-bbox="909 996 1412 1344"> <thead> <tr> <th>Size \ Area</th> <th>Acc. Qty</th> </tr> </thead> <tbody> <tr> <td>$\phi \leq 0.10$</td> <td>Ignore</td> </tr> <tr> <td>$0.10 < \phi \leq 0.15$</td> <td>2</td> </tr> <tr> <td>$0.15 < \phi \leq 0.25$</td> <td>1</td> </tr> <tr> <td>$0.25 < \phi$</td> <td>0</td> </tr> <tr> <td>Total</td> <td>2 no include $\phi \leq 0.10$</td> </tr> </tbody> </table> <p>Distance between 2 defects should more than 3mm apart.</p>	Size \ Area	Acc. Qty	$\phi \leq 0.10$	Ignore	$0.10 < \phi \leq 0.15$	2	$0.15 < \phi \leq 0.25$	1	$0.25 < \phi$	0	Total	2 no include $\phi \leq 0.10$						
Size \ Area	Acc. Qty																			
$\phi \leq 0.10$	Ignore																			
$0.10 < \phi \leq 0.15$	2																			
$0.15 < \phi \leq 0.25$	1																			
$0.25 < \phi$	0																			
Total	2 no include $\phi \leq 0.10$																			
02	Electrical Defect (Minor defect)	<table border="1" data-bbox="550 1478 1396 1691"> <thead> <tr> <th></th> <th>Display Area</th> <th>Total</th> <th rowspan="3">Note1</th> </tr> </thead> <tbody> <tr> <td>Bright dot</td> <td>0</td> <td>0</td> </tr> <tr> <td>Dark dot</td> <td>N ≤ 2</td> <td>N ≤ 2</td> </tr> <tr> <td>Total dot</td> <td>N ≤ 2</td> <td>N ≤ 2</td> <td></td> </tr> <tr> <td>Mura</td> <td colspan="2">Not visible through 5% ND filters.</td> <td>Note 2</td> </tr> </tbody> </table> <p>Remark: 1. Bright dot caused by scratch and foreign object accords to item 1.</p>		Display Area	Total	Note1	Bright dot	0	0	Dark dot	N ≤ 2	N ≤ 2	Total dot	N ≤ 2	N ≤ 2		Mura	Not visible through 5% ND filters.		Note 2
	Display Area	Total	Note1																	
Bright dot	0	0																		
Dark dot	N ≤ 2	N ≤ 2																		
Total dot	N ≤ 2	N ≤ 2																		
Mura	Not visible through 5% ND filters.		Note 2																	

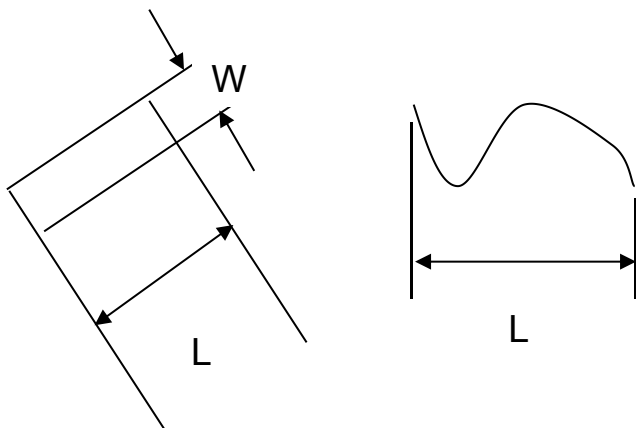
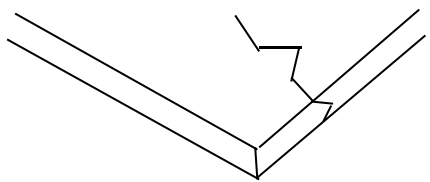
<p>03</p>	<p>Black and White line Scratch Foreign material (Line type) (Minor defect)</p>	 <table border="1" data-bbox="606 705 1236 1019"> <thead> <tr> <th>Length</th> <th>Width</th> <th>Acc. Qty</th> </tr> </thead> <tbody> <tr> <td>/</td> <td>$W \leq 0.03$</td> <td>Ignore</td> </tr> <tr> <td>$L \leq 2.5$</td> <td>$0.03 < W \leq 0.05$</td> <td>3</td> </tr> <tr> <td>$L \leq 2.5$</td> <td>$0.05 < W \leq 0.10$</td> <td>2</td> </tr> <tr> <td>/</td> <td>$0.1 < W$</td> <td>0</td> </tr> <tr> <td colspan="2" style="text-align: center;">Total</td> <td>3</td> </tr> </tbody> </table> <p>Distance between 2 defects should more than 3mm apart. Scratches not viewable through the back of the display are acceptable.</p>	Length	Width	Acc. Qty	/	$W \leq 0.03$	Ignore	$L \leq 2.5$	$0.03 < W \leq 0.05$	3	$L \leq 2.5$	$0.05 < W \leq 0.10$	2	/	$0.1 < W$	0	Total		3
Length	Width	Acc. Qty																		
/	$W \leq 0.03$	Ignore																		
$L \leq 2.5$	$0.03 < W \leq 0.05$	3																		
$L \leq 2.5$	$0.05 < W \leq 0.10$	2																		
/	$0.1 < W$	0																		
Total		3																		
<p>04</p>	<p>Glass Crack (Minor defect)</p>	 <p>Crack is potential to enlarge, any type is not allowed.</p>																		

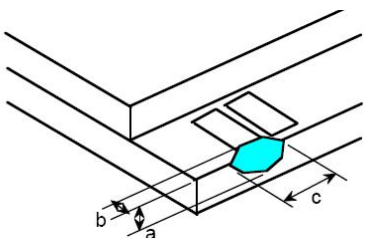
<p>05</p>	<p>Glass Chipping Pad Area: (Minor defect)</p> 	<table border="1" data-bbox="869 1680 1340 1848"> <thead> <tr> <th>Length and Width</th> <th>Acc. Qty</th> </tr> </thead> <tbody> <tr> <td>$c > 3.0, b < 1.0$</td> <td>1</td> </tr> <tr> <td>$c < 3.0, b < 1.0$</td> <td>3</td> </tr> <tr> <td colspan="2" style="text-align: center;">$a < \text{Glass Thickness}$</td> </tr> </tbody> </table>	Length and Width	Acc. Qty	$c > 3.0, b < 1.0$	1	$c < 3.0, b < 1.0$	3	$a < \text{Glass Thickness}$	
Length and Width	Acc. Qty									
$c > 3.0, b < 1.0$	1									
$c < 3.0, b < 1.0$	3									
$a < \text{Glass Thickness}$										

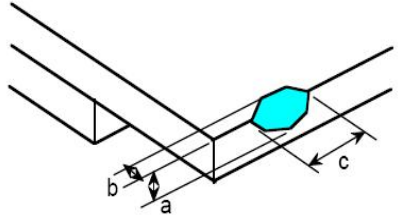
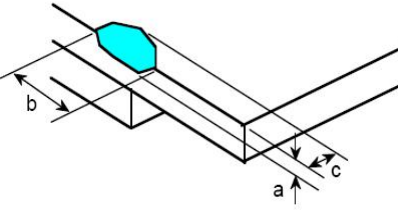
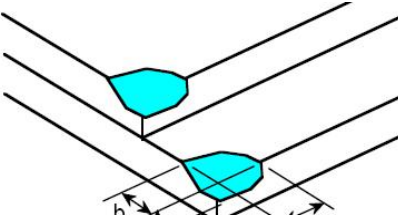
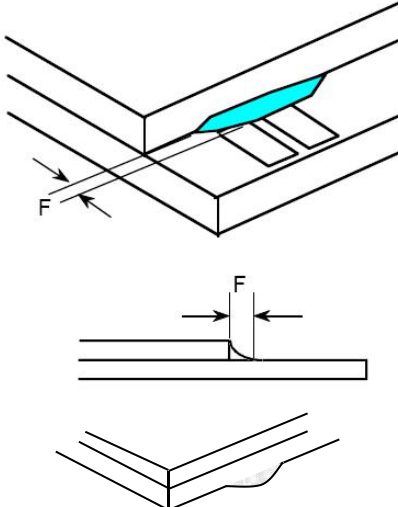
06	<p>Glass Chipping Rear of Pad Area: (Minor defect)</p> 	<table border="1"> <thead> <tr> <th>Length and Width</th> <th>Acc. Qty</th> </tr> </thead> <tbody> <tr> <td>$c > 3.0, b < 1.0$</td> <td>1</td> </tr> <tr> <td>$c < 3.0, b < 1.0$</td> <td>2</td> </tr> <tr> <td>$c < 3.0, b < 0.5$</td> <td>4</td> </tr> <tr> <td colspan="2" style="text-align: center;">$a < \text{Glass Thickness}$</td> </tr> </tbody> </table>	Length and Width	Acc. Qty	$c > 3.0, b < 1.0$	1	$c < 3.0, b < 1.0$	2	$c < 3.0, b < 0.5$	4	$a < \text{Glass Thickness}$	
Length and Width	Acc. Qty											
$c > 3.0, b < 1.0$	1											
$c < 3.0, b < 1.0$	2											
$c < 3.0, b < 0.5$	4											
$a < \text{Glass Thickness}$												
07	<p>Glass Chipping Except Pad Area: (Minor defect)</p> 	<table border="1"> <thead> <tr> <th>Length and Width</th> <th>Acc. Qty</th> </tr> </thead> <tbody> <tr> <td>$c > 3.0, b < 1.0$</td> <td>1</td> </tr> <tr> <td>$c < 3.0, b < 1.0$</td> <td>2</td> </tr> <tr> <td>$c < 3.0, b < 0.5$</td> <td>4</td> </tr> <tr> <td colspan="2" style="text-align: center;">$a < \text{Glass Thickness}$</td> </tr> </tbody> </table>	Length and Width	Acc. Qty	$c > 3.0, b < 1.0$	1	$c < 3.0, b < 1.0$	2	$c < 3.0, b < 0.5$	4	$a < \text{Glass Thickness}$	
Length and Width	Acc. Qty											
$c > 3.0, b < 1.0$	1											
$c < 3.0, b < 1.0$	2											
$c < 3.0, b < 0.5$	4											
$a < \text{Glass Thickness}$												
08	<p>Glass Corner Chipping: (Minor defect)</p> 	<table border="1"> <thead> <tr> <th>Length and Width</th> <th>Acc. Qty</th> </tr> </thead> <tbody> <tr> <td>$c < 3.0, b < 3.0$</td> <td>Ignore</td> </tr> <tr> <td colspan="2" style="text-align: center;">$a < \text{Glass Thickness}$</td> </tr> </tbody> </table>	Length and Width	Acc. Qty	$c < 3.0, b < 3.0$	Ignore	$a < \text{Glass Thickness}$					
Length and Width	Acc. Qty											
$c < 3.0, b < 3.0$	Ignore											
$a < \text{Glass Thickness}$												
09	<p>Glass Burr: (Minor defect)</p> 	<table border="1"> <thead> <tr> <th>Length</th> <th>Acc. Qty</th> </tr> </thead> <tbody> <tr> <td>$F < 1.0$</td> <td>Ignore</td> </tr> </tbody> </table> <p>Glass burr don't affect assemble and module dimension.</p>	Length	Acc. Qty	$F < 1.0$	Ignore						
Length	Acc. Qty											
$F < 1.0$	Ignore											

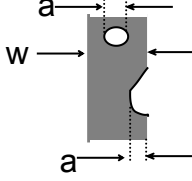
10	<p>FPC Defect: (Minor defect)</p> 	<p>10.1 Dent, pinhole width $a < w/3$. (w: circuitry width.) 10.2 Open circuit is unacceptable. 10.3 No oxidation, contamination and distortion.</p>										
11	Bubble on Polarizer (Minor defect)	<table border="1" data-bbox="743 577 1214 790"> <thead> <tr> <th>Diameter</th> <th>Acc. Qty</th> </tr> </thead> <tbody> <tr> <td>$\varphi \leq 0.20$</td> <td>Ignore</td> </tr> <tr> <td>$0.20 < \varphi \leq 0.30$</td> <td>4</td> </tr> <tr> <td>$0.30 < \varphi \leq 0.50$</td> <td>1</td> </tr> <tr> <td>$0.50 < \varphi$</td> <td>None</td> </tr> </tbody> </table>	Diameter	Acc. Qty	$\varphi \leq 0.20$	Ignore	$0.20 < \varphi \leq 0.30$	4	$0.30 < \varphi \leq 0.50$	1	$0.50 < \varphi$	None
Diameter	Acc. Qty											
$\varphi \leq 0.20$	Ignore											
$0.20 < \varphi \leq 0.30$	4											
$0.30 < \varphi \leq 0.50$	1											
$0.50 < \varphi$	None											
12	Dent on Polarizer (Minor defect)	<table border="1" data-bbox="743 851 1214 1064"> <thead> <tr> <th>Diameter</th> <th>Acc. Qty</th> </tr> </thead> <tbody> <tr> <td>$\varphi \leq 0.20$</td> <td>Ignore</td> </tr> <tr> <td>$0.20 < \varphi \leq 0.30$</td> <td>4</td> </tr> <tr> <td>$0.30 < \varphi \leq 0.50$</td> <td>1</td> </tr> <tr> <td>$0.50 < \varphi$</td> <td>None</td> </tr> </tbody> </table>	Diameter	Acc. Qty	$\varphi \leq 0.20$	Ignore	$0.20 < \varphi \leq 0.30$	4	$0.30 < \varphi \leq 0.50$	1	$0.50 < \varphi$	None
Diameter	Acc. Qty											
$\varphi \leq 0.20$	Ignore											
$0.20 < \varphi \leq 0.30$	4											
$0.30 < \varphi \leq 0.50$	1											
$0.50 < \varphi$	None											
13	Bezel	<p>13.1 No rust, distortion on the Bezel. 13.2 No visible fingerprints, stains or other contamination.</p>										
14	Touch Panel	<p>D: Diameter W: width L: length 14.1 Spot: $D < 0.25$ is acceptable $0.25 \leq D \leq 0.4$ 2dots are acceptable and the distance between defects should more than 10 mm. $D > 0.4$ is unacceptable 14.2 Dent: $D > 0.40$ is unacceptable 14.3 Scratch: $W \leq 0.03$, $L \leq 10$ is acceptable, $0.03 < W \leq 0.10$, $L \leq 10$ is acceptable Distance between 2 defects should more than 10 mm. $W > 0.10$ is unacceptable.</p>										
15	PCB	<p>15.1 No distortion or contamination on PCB terminals. 15.2 All components on PCB must same as documented on the BOM/component layout. 15.3 Follow IPC-A-600F.</p>										
16	Soldering	Follow IPC-A-610C standard										

17	Electrical Defect (Major defect)	<p>The below defects must be rejected.</p> <p>17.1 Missing vertical / horizontal segment, 17.2 Abnormal Display. 17.3 No function or no display. 17.4 Current exceeds product specifications. 17.5 LCD viewing angle defect. 17.6 No Backlight. 17.7 Dark Backlight. 17.8 Touch Panel no function.</p>
----	-------------------------------------	--

Remark: LCD Panel Broken shall be rejected. Defect out of LCD viewing area is acceptable.

10.7. Classification of Defects

10.7.1. Visual defects (Except no / wrong label) are treated as minor defect and electrical defect is major.

10.7.2. Two minor defects are equal to one major in lot sampling inspection.

10.8. Identification/marketing criteria

Any unit with illegible / wrong /double or no marking/ label shall be rejected.

10.9. Packing

10.9.1. There should be no damage of the outside carton box, each packaging box should have one identical label.

10.9.2. Modules inside package box should have compliant mark.

10.9.3. All direct package materials shall offer ESD protection.

Note1: Bright dot is defined as the defective area of the dot is larger than 50% of one sub-pixel area.

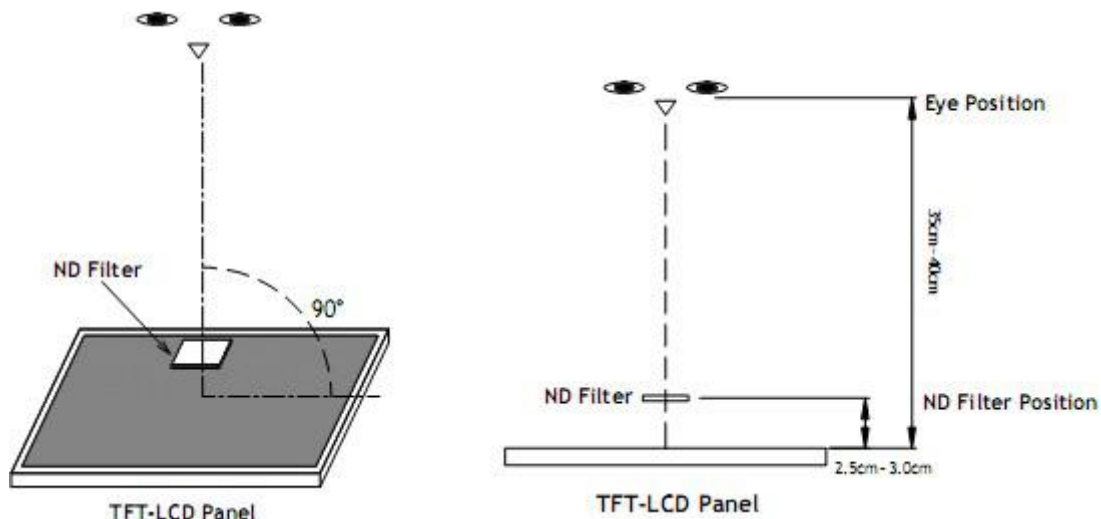

Bright dot: The bright dot size defect at black display pattern. It can be recognized by 2% transparency of filter when the distance between eyes and panel is $350\text{mm} \pm 50\text{mm}$.

Dark dot: Cyan, Magenta or Yellow dot size defect at white display pattern. It can be recognized by 5% transparency of filter when the distance between eyes and panel is $350\text{mm} \pm 50\text{mm}$.

Note2: Mura on display which appears darker / brighter against background brightness on parts of display area.

11. Reliability Specification

No	Item	Condition	Quantity	Criteria
1	High Temperature Operating	70°C, 96Hrs	2	GB/T2423.2-2008
2	Low Temperature Operating	-20°C, 96Hrs	2	GB/T2423.1-2008
3	High Humidity	50°C, 90%RH, 96Hrs	2	GB/T2423.3-2006
4	High Temperature Storage	80°C, 96Hrs	2	GB/T2423.2-2008
5	Low Temperature Storage	-30°C, 96Hrs	2	GB/T2423.1-2008
6	Thermal Cycling Test	-20°C, 60min~70°C, 60min, 20 cycles.	2	GB/T2423.22-2012
7	Packing vibration	Frequency range:10Hz~50Hz Acceleration of gravity:5G X, Y, Z 30 min for each direction.	2	GB/T5170.14-2009
8	Electrical Static Discharge	Air: ±8KV 150pF/330 Ω 5 times Contact: ±4KV 150pF/330 Ω 5 times	2	GB/T17626.2-2006
9	Drop Test (Packaged)	Height:80 cm,1 corner, 3 edges, 6 surfaces.	2	GB/T2423.8-1995

Note1. No deflection cosmetic and operational function allowable.

Note2. Total current Consumption should be below double of initial value.

12. Precautions and Warranty

12.1. Safety

- 12.1.1. The liquid crystal in the LCD is poisonous. Do not put it in your mouth. If the liquid crystal touches your skin or clothes, wash it off immediately using soap and water.
- 12.1.2. Since the liquid crystal cells are made of glass, do not apply strong impact on them. Handle with care.

12.2. Handling

- 12.2.1. Reverse and use within ratings in order to keep performance and prevent damage.
- 12.2.2. Do not wipe the polarizer with dry cloth, as it might cause scratch. If the surface of the LCD needs to be cleaned, wipe it swiftly with cotton or other soft cloth soaked with petroleum IPA, do not use other chemicals.

12.3. Storage

- 12.3.1. Do not store the LCD module beyond the specified temperature ranges.
- 12.3.2. Strong light exposure causes degradation of polarizer and color filter.

12.4. Metal Pin (Apply to Products with Metal Pins)

12.4.1. Pins of LCD and Backlight

12.4.1.1. Solder tip can touch and press on the tip of Pin LEAD during the soldering

12.4.1.2. Recommended Soldering Conditions

Solder Type: Sn96.3~94-Ag3.3~4.3-Cu0.4~1.1

Maximum Solder Temperature: 370 °C

Maximum Solder Time: 3s at the maximum temperature

Recommended Soldering Temp: 350±20 °C

Typical Soldering Time: ≤3s

12.4.1.3. Solder Wetting

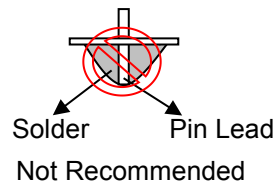
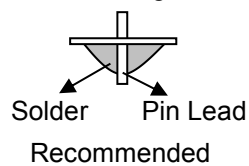

12.4.2. Pins of EL

12.4.2.1. Solder tip can touch and press on the tip of EL leads during soldering.

12.4.2.2. No Solder Paste on the soldering pad on the motherboard is recommended.

12.4.2.3. Recommended Soldering Conditions

Solder type: Nippon Alimit Leadfree SR-34, size 0.5mm

Recommended Solder Temperature: 270~290 °C

Typical Soldering Time: ≤2s

Minimum solder distance from EL lamp (body): 2.0mm

12.4.2.4. No horizontal press on the EL leads during soldering.

12.4.2.5. 180° bend EL leads three times is not allowed.

12.4.2.6. Solder Wetting



12.4.2.7. The type of the solder iron:



12.4.2.8. Solder Pad

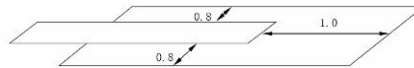

12.5. Operation

- 12.5.1. Do not drive LCD with DC voltage
- 12.5.2. Response time will increase below lower temperature
- 12.5.3. Display may change color with different temperature
- 12.5.4. Mechanical disturbance during operation, such as pressing on the display area, may cause the segments to appear "fractured".
- 12.5.5. Do not connect or disconnect the LCM to or from the system when power is on.
- 12.5.6. Never use the LCM under abnormal condition of high temperature and high humidity.
- 12.5.7. Module has high frequency circuits. Sufficient suppression to the electromagnetic interface shall be done by system manufacturers. Grounding and shielding methods may be important to minimize the interference.
- 12.5.8. Do not display the fixed pattern for long time (we suggest the time not longer than one hour) because it may develop image sticking due to the TFT structure.

12.6. Static Electricity

- 12.6.1. CMOS LSIs are equipped in this unit, so care must be taken to avoid the electro-static charge, by ground human body, etc.
- 12.6.2. The normal static prevention measures should be observed for work clothes and benches.
- 12.6.3. The module should be kept into anti-static bags or other containers resistant to static for storage.

12.7. Limited Warranty

- 12.7.1. Our warranty liability is limited to repair and/or replacement. We will not be responsible for any consequential loss.
- 12.7.2. If possible, we suggest customer to use up all modules in six months. If the module storage time over twelve months, we suggest that recheck it before the module be used.
- 12.7.3. After the product shipped, any product quality issues must be feedback within three months, otherwise, we will not be responsible for the subsequent or consequential events.

13. Packaging

TBD

14. Outline Drawing

