

# PRODUCT SPECIFICATION

## 3.5" MVA TFT LCD MODULE

MODEL: T035320480-A6MMN-001 Ver:1.1

**ROHS**

< ◇ > Preliminary Specification

< ◆ > Finally Specification

CUSTOMER'S APPROVAL	
CUSTOMER :	
SIGNATURE:	DATE:

APPROVED BY	PM REVIEWED	PD REVIEWED	PREPARED BY

---

---

### Revision History

Revision	Date	Originator	Detail	Remarks
1.0	2016.04.15	ZFY	Initial Release	
1.1	2018.04.20	ZDT	Add LED working life Modify many details	P5 P24-P25

## Table of Contents

No.	Item	Page
1.	General Description.....	4
2.	Module Parameter.....	4
3.	Absolute Maximum Ratings.....	4
4.	DC Characteristics.....	5
5.	Backlight Characteristic.....	5
	5.1. Backlight Characteristics.....	5
	5.2. Backlighting circuit.....	5
6.	Optical Characteristics.....	6
	6.1. Optical Characteristics.....	6
	6.2. Definition of Response Time.....	6
	6.3. Definition of Contrast Ratio.....	7
	6.4. Definition of Viewing Angles.....	7
	6.5. Definition of Color Appearance.....	8
	6.6. Definition of Surface Luminance, Uniformity and Transmittance.....	8
7.	Block Diagram and Power Supply.....	9
8.	Interface Pins Definition.....	10
	8.1. FPC CON.....	10
9.	AC Characteristics.....	11
10.	Quality Assurance.....	16
	10.1. Purpose.....	16
	10.2. Standard for Quality Test.....	16
	10.3. Nonconforming Analysis & Disposition.....	16
	10.4. Agreement Items.....	16
	10.5. Standard of the Product Visual Inspection.....	16
	10.6. Inspection Specification.....	17
	10.7. Classification of Defects.....	22
	10.8. Identification/marketing criteria.....	22
	10.9. Packaging.....	22
11.	Reliability Specification.....	23
12.	Precautions and Warranty.....	24
	12.1. Safety.....	24
	12.2. Handling.....	24
	12.3. Storage.....	24
	12.4. Metal Pin (Apply to Products with Metal Pins).....	24
	12.5. Operation.....	25
	12.6. Static Electricity.....	25
	12.7. Limited Warranty.....	25
13.	Packaging.....	26
14.	Outline Drawing.....	27

## 1. General Description

The specification is a transmissive type color active matrix liquid crystal display (LCD) which uses amorphous thin film transistor (TFT) as switching devices. This product is composed of a TFT-LCD panel, driver ICs and a backlight unit.

## 2. Module Parameter

Features	Details	Unit
Display Size(Diagonal)	3.5"	
LCD type	MVA TFT	
Display Mode	Transmissive /Normally White	
Resolution	320RGB x 480	Pixels
View Direction	FULL VIEW	Best Image
Module Outline	55.7(H) x 85(V) x 2.7(T) (Note1 )	mm
Active Area	48.96 (H) x73.44(V)	mm
Pixel Pitch	153(H) x 153(V)	um
Pixel Arrangement	RGB Vertical Stripe	
Display Colors	262K	
Interface	RGB or 8/9/16/18 Parallel Interface	
Driver IC	ILI9488	-
With or Without Touch Panel	Without	
Operating Temperature	<b>-20~70</b>	°C
Storage Temperature	<b>-30~80</b>	°C
Weight	TBD	g

Note 1: Exclusive hooks, posts, FFC/FPC tail etc.

## 3. Absolute Maximum Ratings

GND =0V, Ta=25°C

Item	Symbol	Min.	Max.	Unit
Power supply voltage	VDD	-0.3	3.3	V
Storage temperature	T <sub>STG</sub>	<b>-30</b>	<b>+80</b>	°C
Operating temperature	T <sub>OP</sub>	<b>-20</b>	<b>+70</b>	°C

**Note 1:** If Ta below 50°C, the maximal humidity is 90%RH, if Ta over 50°C, absolute humidity should be less than 60%RH.

**Note 2:** The response time will be extremely slow when the operating temperature is around -10°C, and the back ground will become darker at high temperature operating.

#### 4. DC Characteristics

Item	Symbol	Min.	Typ.	Max.	Unit	
Supply Voltage	VDD	2.5	2.8	3.3	V	
Logic Low input voltage	V <sub>IL</sub>	-0.3	-	0.3*VDD	V	
Logic High input voltage	V <sub>IH</sub>	0.7*VDD	-	VDD	V	
Logic Low output voltage	V <sub>OL</sub>	0	-	0.2*VDD	V	
Logic High output voltage	V <sub>OH</sub>	0.8*VDD	-	VDD	V	
Current Consumption All Black	Logic	I <sub>CC+</sub> I <sub>IN</sub>	-	10	-	mA
	Analog					

#### 5. Backlight Characteristic

##### 5.1. Backlight Characteristics

Item	Symbol	Condition	Min.	Typ.	Max.	Unit
Forward Voltage	V <sub>F</sub>	Ta=25 °C, I <sub>F</sub> =20mA/LED	2.8	3.2	3.4	V
Forward Current	I <sub>F</sub>	Ta=25 °C, V <sub>F</sub> =3.2V/LED	-	120	-	mA
Power dissipation	P <sub>D</sub>	-	-	384	-	mW
Uniformity	Avg	-	80	-	-	%
LED working life(25°C)	-	-	-	30,000	-	Hrs
Drive method	Constant current					
LED Configuration	6 White LEDs in parallel					

Note1: LED life time defined as follows: The final brightness is at 50% of original brightness.  
The environmental conducted under ambient air flow, at Ta=25±2 °C,60%RH±5%, I<sub>F</sub>=20mA

##### 5.2. Backlighting circuit

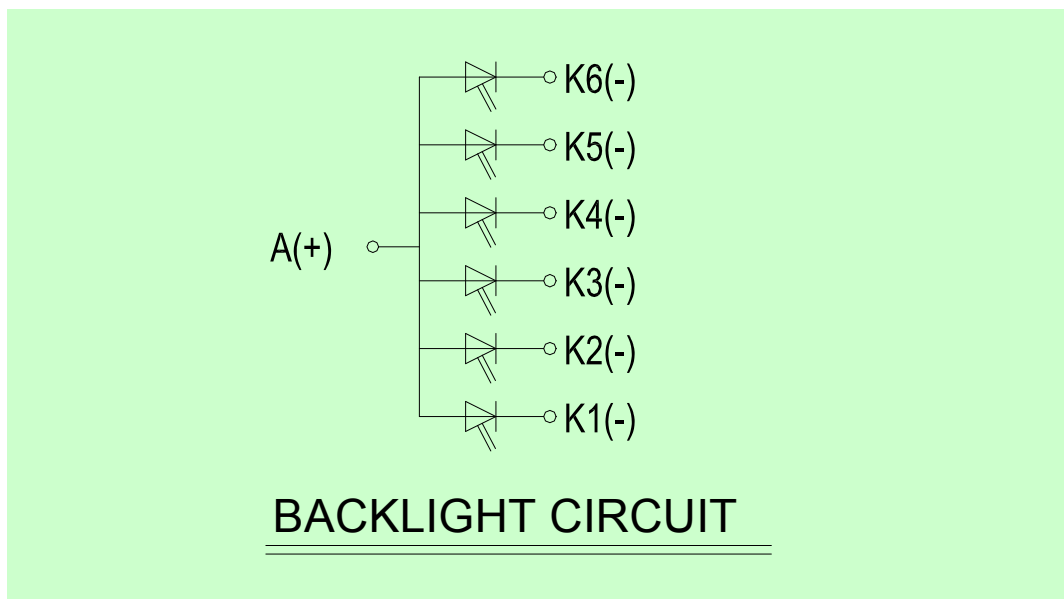

## 6. Optical Characteristics

### 6.1. Optical Characteristics

Ta=25°C,  $V_{DD}=2.8V$

	Item	Symbol	Condition	Specification			Unit	
				Min.	Typ.	Max.		
Backlight On (Transmissive Mode)	Luminance on TFT( $I_f=20mA/LED$ )	Lv	Normally viewing angle $\theta_x = \phi_y = 0^\circ$	210	270	-	cd/m <sup>2</sup>	
	Contrast ratio(See 6.3)	CR		-	500	-		
	Response time (See 6.2)	T <sub>R</sub>		-	20	40	ms	
		T <sub>F</sub>						
	Chromaticity Transmissive (See 6.5)	Red	X <sub>R</sub>		TBD		-	
			Y <sub>R</sub>		TBD		-	
		Green	X <sub>G</sub>		TBD		-	
			Y <sub>G</sub>		TBD		-	
		Blue	X <sub>B</sub>		TBD		-	
			Y <sub>B</sub>		TBD		-	
	White	X <sub>W</sub>		TBD		-		
		Y <sub>W</sub>		TBD		-		
	Viewing Angle (See 6.4)	Horizontal	$\theta_{x+}$	Center CR≥10	60	75	-	Deg.
			$\theta_{x-}$		60	75	-	
Vertical		$\phi_{y+}$	60		75	-		
		$\phi_{y-}$	60		75	-		
	NTSC Ratio(Gamut)	-	-	-	60	-	%	

### 6.2. Definition of Response Time

#### 6.2.1. Normally Black Type (Negative)

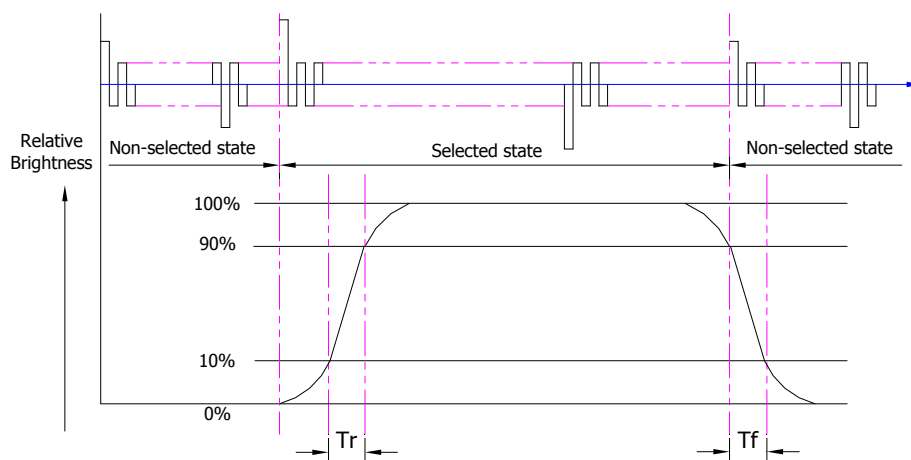

$T_r$  is the time it takes to change from non-selected stage with relative luminance 10% to selected state with relative luminance 90%;

$T_f$  is the time it takes to change from selected state with relative luminance 90% to

non-selected state with relative luminance 10%.

Note: Measuring machine: LCD-5100

### 6.2.2. Normally White Type (Positive)

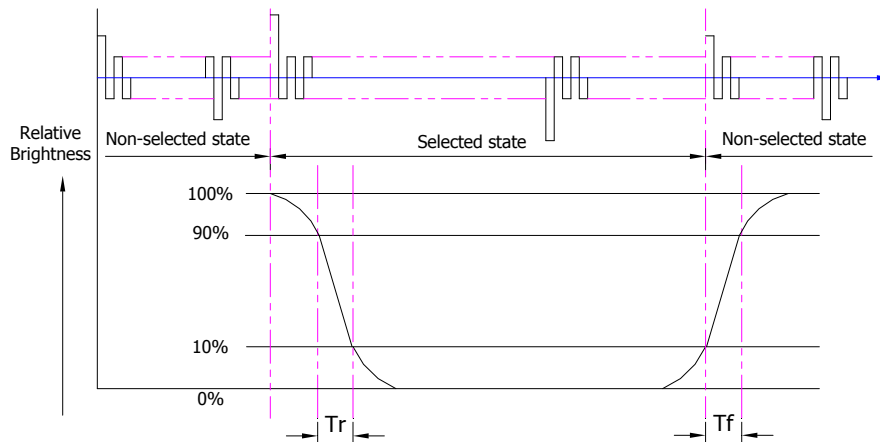

$T_r$  is the time it takes to change from non-selected stage with relative luminance 90% to selected state with relative luminance 10%;

$T_f$  is the time it takes to change from selected state with relative luminance 10% to non-selected state with relative luminance 90%;

Note: Measuring machine: LCD-5100 or EQUI

### 6.3. Definition of Contrast Ratio

Contrast is measured perpendicular to display surface in reflective and transmissive mode.

The measurement condition is:

Measuring Equipment	Eldim or Equivalent
Measuring Point Diameter	3mm//1mm
Measuring Point Location	Active Area centre point
Test pattern	A: All Pixels white
	B: All Pixel black
Contrast setting	Maximum

Definitions: CR (Contrast) = Luminance of White Pixel / Luminance of Black Pixel

### 6.4. Definition of Viewing Angles

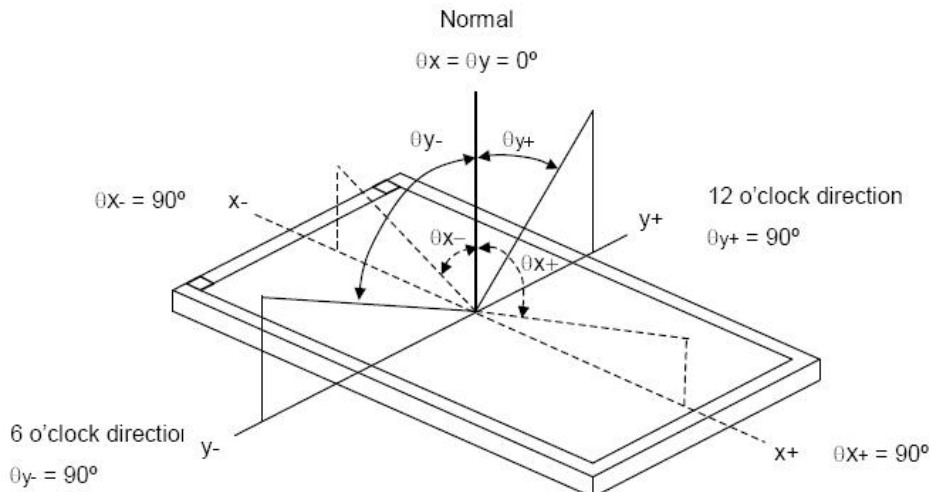

Measuring machine: LCD-5100 or EQUI

### 6.5. Definition of Color Appearance

R,G,B and W are defined by (x, y) on the IE chromaticity diagram

NTSC=area of RGB triangle/area of NTSC triangleX100%

Measuring picture: Red, Green, Blue and White (Measuring machine: BM-7)

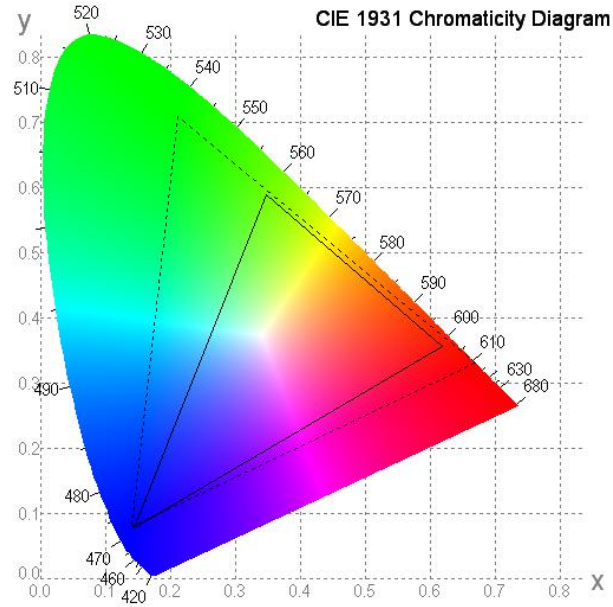

### 6.6. Definition of Surface Luminance, Uniformity and Transmittance

Using the transmissive mode measurement approach, measure the white screen luminance of the display panel and backlight.

6.6.1. Surface Luminance:  $L_V = \text{average}(L_{P1}:L_{P9})$

6.6.2. Uniformity =  $\text{Minimal}(L_{P1}:L_{P9}) / \text{Maximal}(L_{P1}:L_{P9}) * 100\%$

6.6.3. Transmittance =  $L_V \text{ on LCD} / L_V \text{ on Backlight} * 100\%$

Note: Measuring machine: BM-7

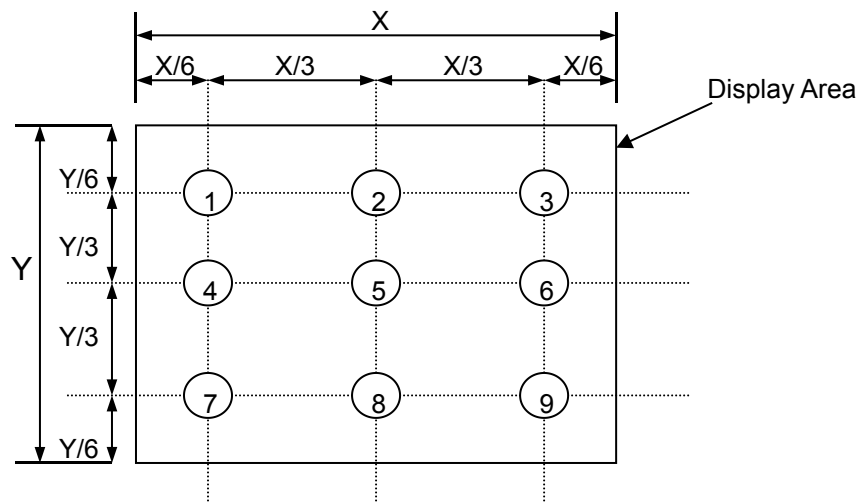



## 7. Block Diagram and Power Supply

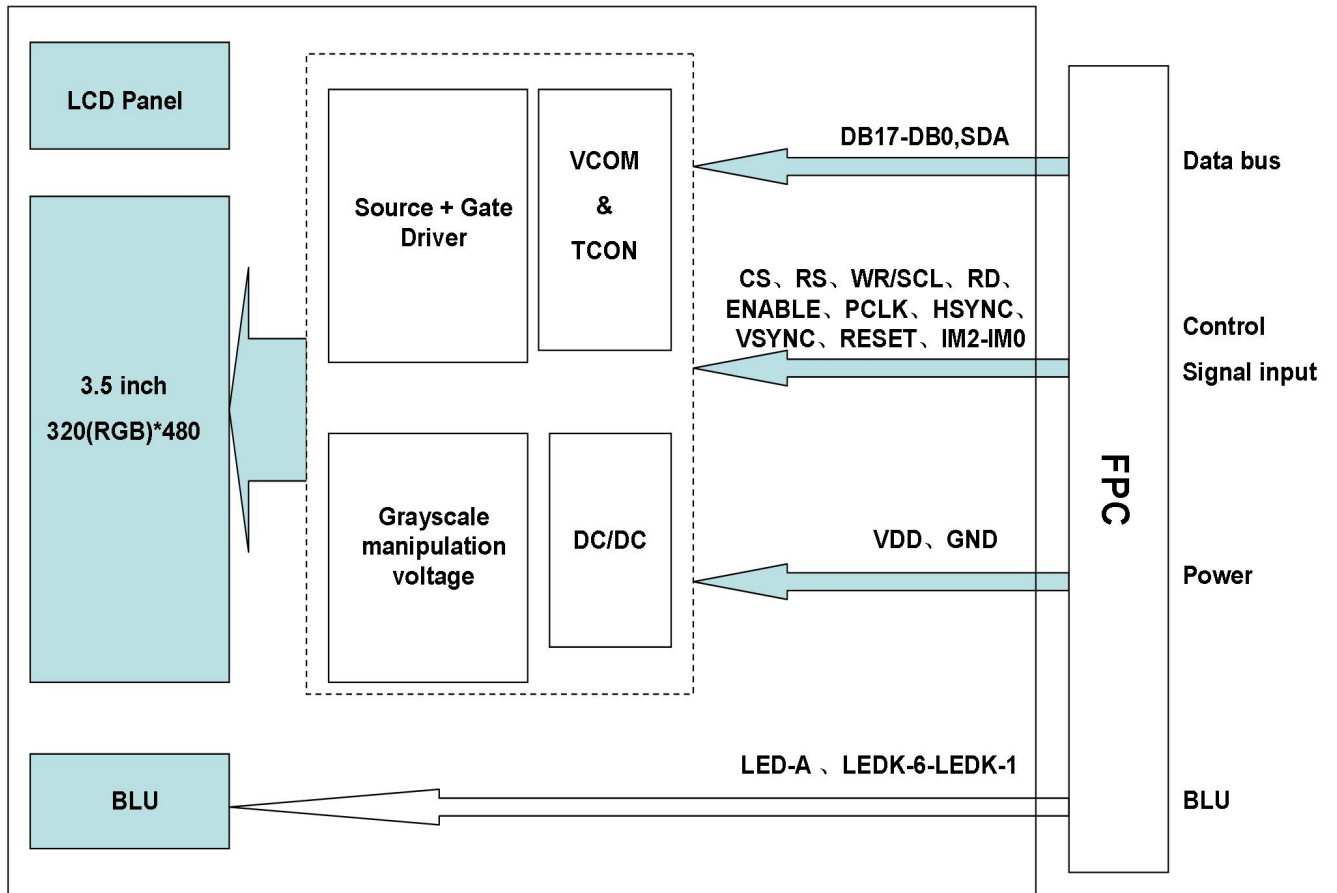

## 8. Interface Pins Definition

### 8.1. FPC CON

Connector type : FH23-51S-0.3SHW(05) or equivalent

No.	Symbol	Function																																				
1	TE	Tearing effect output pin																																				
2	GND	Power Ground																																				
3-4	VDD	Power supply for LCM (2.8V TYPE).																																				
5	CS	Chip select signal																																				
6	RS	Command/Display data selection signal																																				
7	WR/SCL	DBI Type B:WRX pin, serves as a write signal DBI Type C:SCL pin as Serial Clock when operates in the serial interface																																				
8	RD	LCD driver read enable																																				
9	SDA	Serial data input pin.																																				
10	RESET	Reset input pin. Signal is active low.																																				
11-28	DB0-DB17	Data bus																																				
29	ENABLE	Data Enable signal.																																				
30	PCLK	Pixel clock signal for DPI I/F mode.																																				
31	HSYNC	Horizontal Sync Signal																																				
32	VSYNC	Vertical Sync Signal																																				
33 34 35	IM2 IM1 IM0	Select the MPU system interface mode:																																				
		<table border="1"> <thead> <tr> <th>IM2</th> <th>IM1</th> <th>IM0</th> <th>Interface mode</th> </tr> </thead> <tbody> <tr> <td>0</td> <td>0</td> <td>0</td> <td>Not use</td> </tr> <tr> <td>0</td> <td>0</td> <td>0</td> <td>DBI Type B 18-bit bus(DB_EN=0)</td> </tr> <tr> <td>0</td> <td>0</td> <td>1</td> <td>DBI Type B 9-bit bus</td> </tr> <tr> <td>0</td> <td>1</td> <td>0</td> <td>DBI Type B 16-bit bus</td> </tr> <tr> <td>0</td> <td>1</td> <td>1</td> <td>DBI Type B 8-bit bus</td> </tr> <tr> <td>1</td> <td>0</td> <td>1</td> <td>DBI Type C Option 1(3-line SPI)</td> </tr> <tr> <td>1</td> <td>1</td> <td>0</td> <td>Not use</td> </tr> <tr> <td>1</td> <td>1</td> <td>1</td> <td>DBI Type C Option 1(4-line SPI)</td> </tr> </tbody> </table>	IM2	IM1	IM0	Interface mode	0	0	0	Not use	0	0	0	DBI Type B 18-bit bus(DB_EN=0)	0	0	1	DBI Type B 9-bit bus	0	1	0	DBI Type B 16-bit bus	0	1	1	DBI Type B 8-bit bus	1	0	1	DBI Type C Option 1(3-line SPI)	1	1	0	Not use	1	1	1	DBI Type C Option 1(4-line SPI)
		IM2	IM1	IM0	Interface mode																																	
		0	0	0	Not use																																	
		0	0	0	DBI Type B 18-bit bus(DB_EN=0)																																	
		0	0	1	DBI Type B 9-bit bus																																	
		0	1	0	DBI Type B 16-bit bus																																	
		0	1	1	DBI Type B 8-bit bus																																	
		1	0	1	DBI Type C Option 1(3-line SPI)																																	
		1	1	0	Not use																																	
1	1	1	DBI Type C Option 1(4-line SPI)																																			
36	NC(YD)	No Connection																																				
37	NC(XL)	No Connection																																				
38	NC(YU)	No Connection																																				
39	NC(XR)	No Connection																																				
40-45	LED-K1-LEDK6	Cathode for back light driver voltage																																				
46	LED-A	Anode for back light driver voltage																																				
47	GND	Power Ground																																				
48-51	NC	No Connection																																				

## 9. AC Characteristics

### 9.1. DBI Type B (Display Parallel 8-/9-/16-/18-/24-bit interface) Timing Characteristics

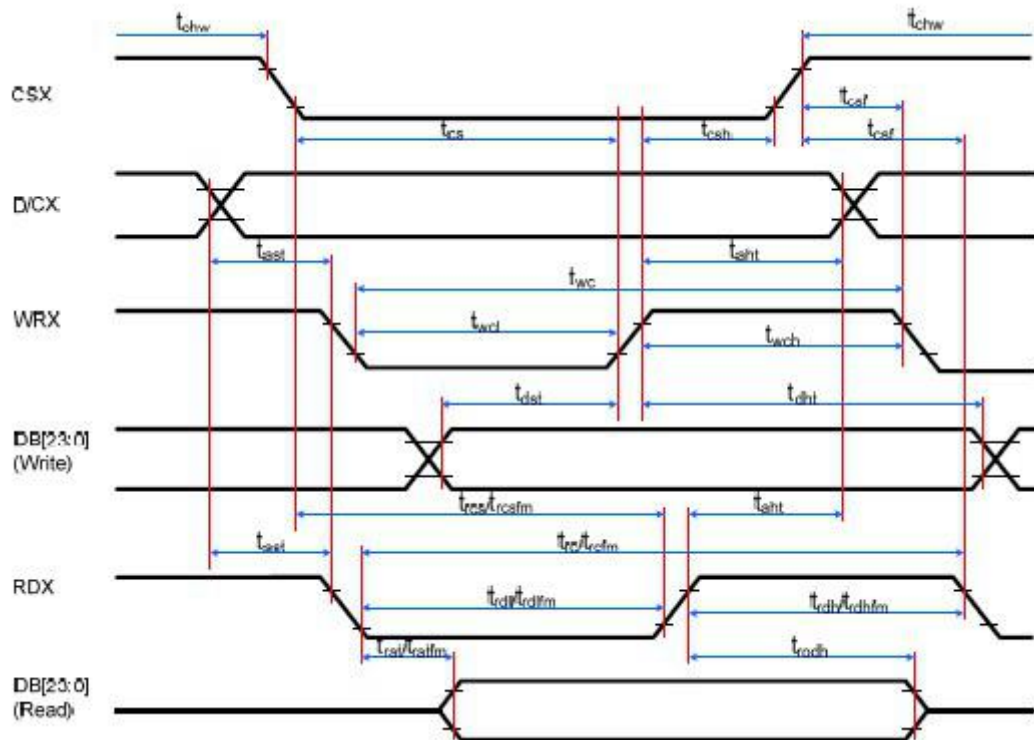

Signal	Symbol	Parameter	min	max	Unit	Description
DCX	tast	Address setup time	0	-	ns	-
	that	Address hold time (Write/Read)	0	-	ns	-
CSX	tchwh	CSX "H" pulse width	0	-	ns	-
	tcs	Chip Select setup time (Write)	15	-	ns	-
	trcs	Chip Select setup time (Read ID)	45	-	ns	-
	trcsfm	Chip Select setup time (Read FM)	355	-	ns	-
	tcsf	Chip Select Wait time (Write/Read)	0	-	ns	-
WRX	twc	Write cycle	30	-	ns	-
	twrh	Write Control pulse H duration	15	-	ns	-
	twrl	Write Control pulse L duration	15	-	ns	-
RDX (FM)	trcfm	Read Cycle (FM)	450	-	ns	When read from Frame Memory
	trdhfm	Read Control H duration (FM)	90	-	ns	
	trdlfm	Read Control L duration (FM)	355	-	ns	
RDX (ID)	trc	Read cycle (ID)	160	-	ns	When read ID data
	trdh	Read Control pulse H duration	90	-	ns	
	trdl	Read Control pulse L duration	45	-	ns	
DB [23:0], DB [17:0], DB [15:0], DB [8:0], DB [7:0]	tdst	Write data setup time	10	-	ns	For maximum, CL=30pF For minimum, CL=8pF
	tdht	Write data hold time	10	-	ns	
	trat	Read access time	-	40	ns	
	tratfm	Read access time	-	340	ns	
	trod	Read output disable time	20	80	ns	

**Notes:**

1.  $T_a = -30$  to  $70$  °C,  $IOVCC = 1.65V$  to  $3.3V$ ,  $VCI = 2.5V$  to  $3.3V$ ,  $AGND = DGND = 0V$
2. Logic high and low levels are specified as 30% and 70% of  $IOVCC$  for input signals.
3. Input signal rising time and falling time:

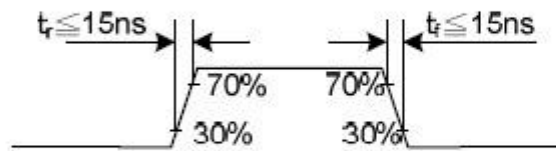

4. The CSX timing:

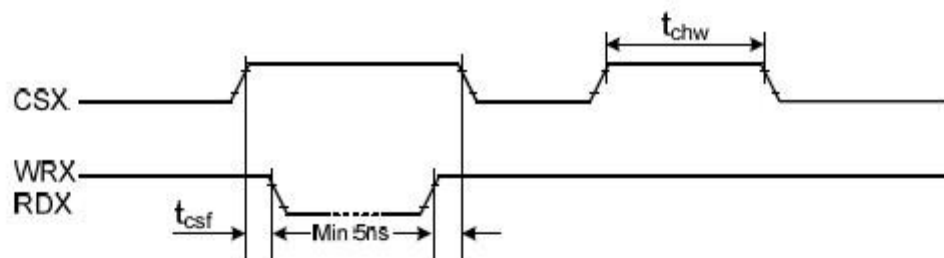

5. The Write to Read or the Read to Write timing:

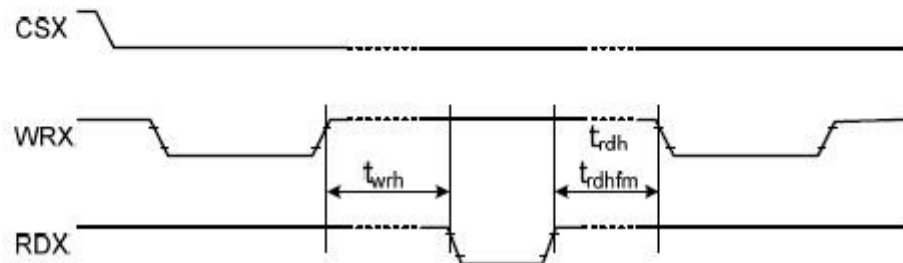

9.2. DBI Type C Option 1 (3-Line SPI System ) Timing Characteristics

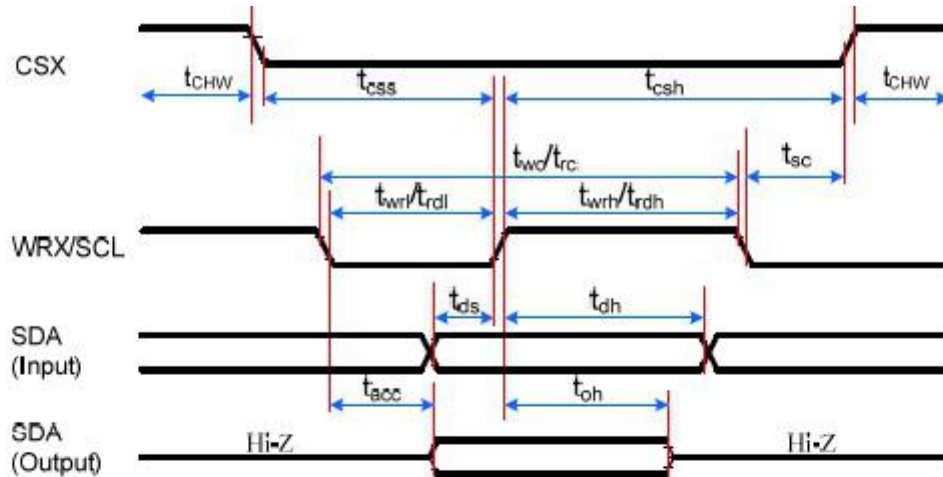

Signal	Symbol	Parameter	min	max	Unit	Description
CSX	t <sub>sc</sub>	SCL-CSX	15	-	ns	
	t <sub>chW</sub>	CSX H Pulse Width	40	-	ns	
	t <sub>css</sub>	Chip select time (Write)	60	-	ns	
	t <sub>csH</sub>	Chip select hold time (Read)	65	-	ns	
SCL	t <sub>wc</sub>	Serial Clock Cycle (Write)	66	-	ns	
	t <sub>wrh</sub>	SCL H Pulse Width (Write)	15	-	ns	
	t <sub>wrl</sub>	SCL L Pulse Width (Write)	15	-	ns	
	t <sub>rc</sub>	Serial Clock Cycle (Read)	150	-	ns	
	t <sub>rdh</sub>	SCL H Pulse Width (Read)	60	-	ns	
	t <sub>rdl</sub>	SCL L Pulse Width (Read)	60	-	ns	
SDA/SDI (Input)	t <sub>ds</sub>	Data setup time (Write)	10	-	ns	
	t <sub>dh</sub>	Data hold time (Write)	10	-	ns	
SDA/SDO (Output)	t <sub>acc</sub>	Access time (Read)	10	50	ns	For maximum CL=30pF
	t <sub>oh</sub>	Output disable time (Read)	15	50	ns	For minimum CL=8pF

Note: T<sub>a</sub> = -30 to 70 °C, I<sub>OVCC</sub> = 1.65V to 3.6V, V<sub>CI</sub> = 2.5V to 3.6V, AGND = DGND = 0V, T = 10+/-0.5ns

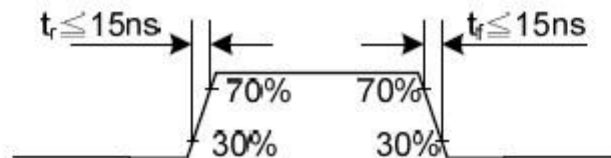

### 9.3. DBI Type C Option 3 (4-Line SPI System ) Timing Characteristics

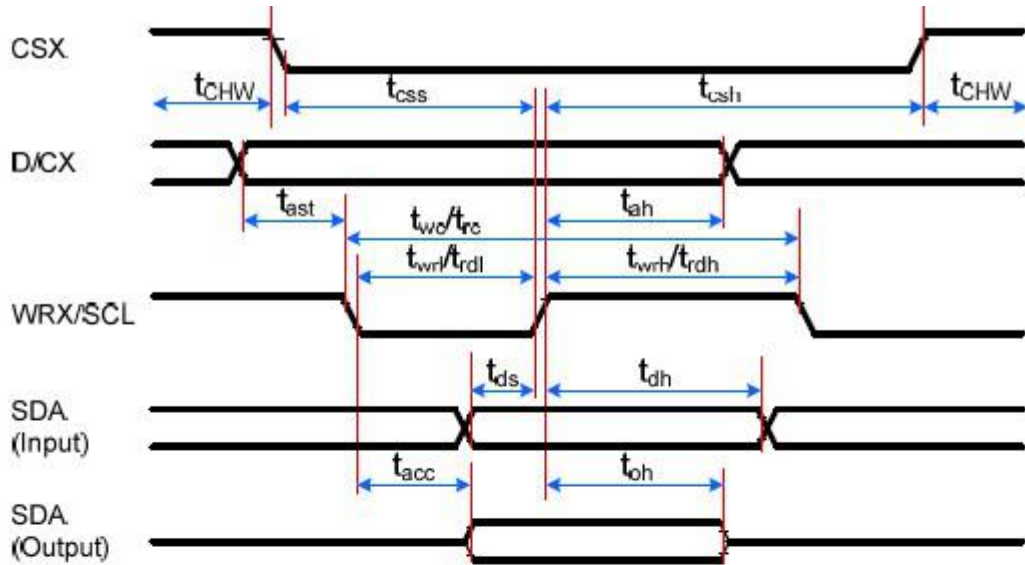

Signal	Symbol	Parameter	min	max	Unit	Description
CSX	tcss	Chip select time (Write)	15	-	ns	
	tcsh	Chip select hold time (Read)	15	-	ns	
	tCHW	CS H pulse width	40	-	ns	
SCL	twc	Serial clock cycle (Write)	50	-	ns	
	twrh	SCL H pulse width (Write)	10	-	ns	
	twrl	SCL L pulse width (Write)	10	-	ns	
	trc	Serial clock cycle (Read)	150	-	ns	
	trdh	SCL H pulse width (Read)	60	-	ns	
	trdl	SCL L pulse width (Read)	60	-	ns	
D/CX	tas	D/CX setup time	10	-	ns	
	tah	D/CX hold time (Write/Read)	10	-	ns	
SDA/SDI (Input)	tds	Data setup time (Write)	10	-	ns	
	tdh	Data hold time (Write)	10	-	ns	
SDA/SDO (Output)	tacc	Access time (Read)	10	50	ns	For maximum CL=30pF
	tod	Output disable time (Read)	15	50	ns	For minimum CL=8pF

**Notes:**

1. Ta = -30 to 70 °C, IOVCC = 1.65V to 3.3V, VCI = 2.5V to 3.3V, AGND = DGND = 0V, T = 10+/-0.5ns.
2. Does not include signal rising and falling times.

9.4. DPI (Display Parallel 16-/18-/24-bit interface ) Timing Characteristics

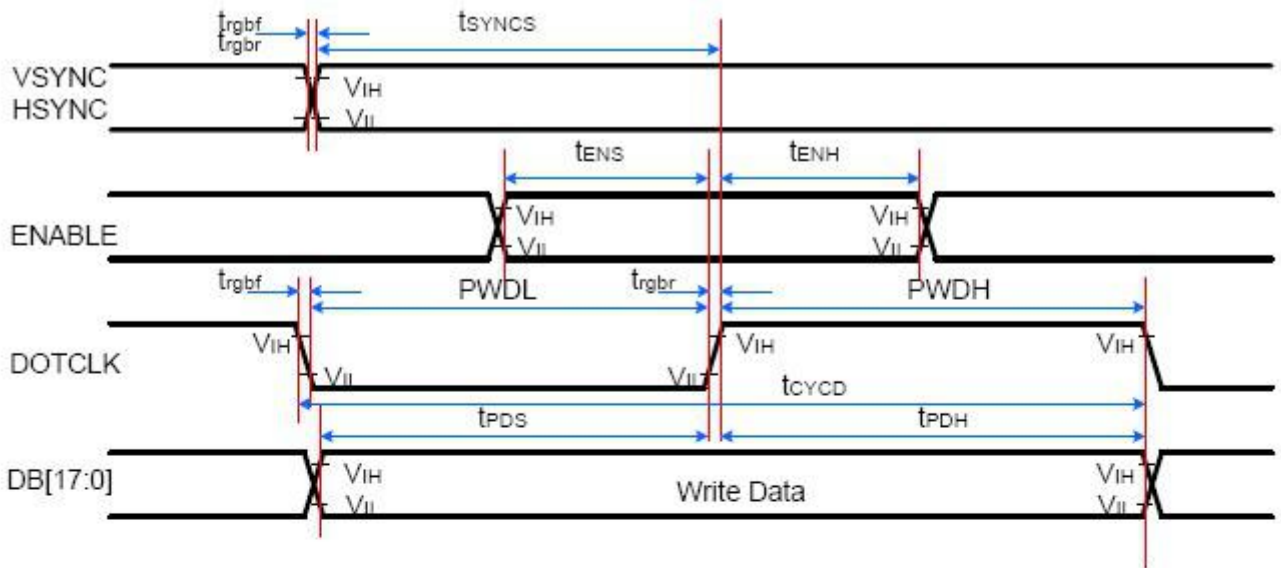

Signal	Symbol	Parameter	min	max	Unit	Description
VSYNC/ HSYNC	$t_{SYNCS}$	VSYNC/HSYNC setup time	15	-	ns	16-/18-/24-bit bus RGB interface mode
	$t_{SYNCH}$	VSYNC/HSYNC hold time	15	-	ns	
ENABLE	$t_{ENS}$	ENABLE setup time	15	-	ns	
	$t_{ENH}$	ENABLE hold time	15	-	ns	
DB [23:0]	$t_{PDS}$	Data setup time	15	-	ns	
	$t_{PDH}$	Data hold time	15	-	ns	
DOTCLK	$PWDH$	DOTCLK high-level period	20	-	ns	
	$PWDL$	DOTCLK low-level period	20	-	ns	
	$t_{CYCD}$	DOTCLK cycle time	50	-	ns	
	$t_{rgbr}, t_{rgbf}$	DOTCLK,HSYNC,VSYNC rise/fall time	-	15	ns	

Note:  $T_a = -30$  to  $70$  °C,  $IOVCC = 1.65V$  to  $3.3V$ ,  $VCI = 2.5V$  to  $3.3V$ ,  $AGND = DGND = 0V$

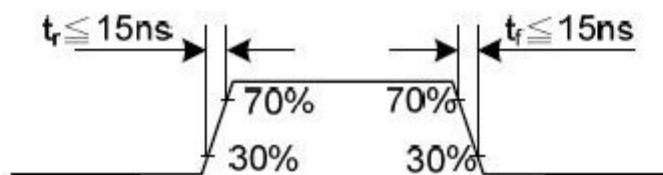

## 10. Quality Assurance

### 10.1. Purpose

This standard for Quality Assurance assures the quality of LCD module products supplied to customer.

### 10.2. Standard for Quality Test

#### 10.2.1 Sampling Plan:

GB2828.1-2012

Single sampling, general inspection level II

#### 10.2.2 Sampling Criteria:

Visual inspection: AQL 1.5%

Electrical functional: AQL 0.65%.

#### 10.2.3 Reliability Test:

Detailed requirement refer to Reliability Test Specification.

### 10.3. Nonconforming Analysis & Disposition

#### 10.3.1 Nonconforming analysis:

10.3.1.1 Customer should provide overall information of non-conforming sample for their complaints.

10.3.1.2 After receipt of detailed information from customer, the analysis of nonconforming parts usually should be finished in one week.

10.3.1.3 If cannot finish the analysis on time, customer will be notified with the progress status.

#### 10.3.2 Disposition of nonconforming:

10.3.2.1 Non-conforming product over PPM level will be replaced.

10.3.2.2 The cause of non-conformance will be analyzed. Corrective action will be discussed and implemented.

### 10.4. Agreement Items

Shall negotiate with customer if the following situation occurs:

10.4.1 There is any discrepancy in standard of quality assurance.

10.4.2 Additional requirement to be added in product specification.

10.4.3 Any other special problem.

### 10.5. Standard of the Product Visual Inspection

#### 10.5.1 Appearance inspection:

10.5.1.1 The inspection must be under illumination about 1000 – 1500 lx, and the distance of view must be at 30cm ± 2cm.

10.5.1.2 The viewing angle should be 45° from the vertical line without reflection light or follows customer's viewing angle specifications.

10.5.1.3 Definition of area: A Zone: Active Area, B Zone: Viewing Area,



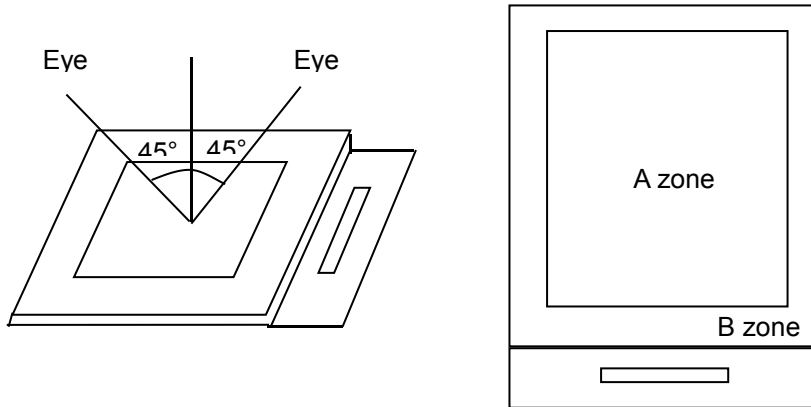

10.5.2 Basic principle:

10.5.2.1 A set of sample to indicate the limit of acceptable quality level must be discussed by both us and customer when there is any dispute happened.

10.5.2.2 New item must be added on time when it is necessary.

10.6. Inspection Specification

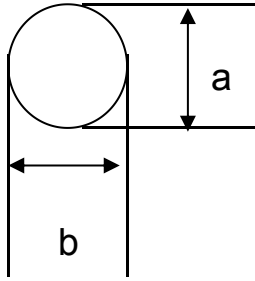
No.	Item	Criteria (Unit: mm)																		
01	Black / White spot Foreign material (Round type) Pinholes Stain Particles inside cell. (Minor defect)	 <p><math>\phi = (a + b) / 2</math></p> <table border="1" data-bbox="909 996 1412 1332"> <thead> <tr> <th>Size \ Area</th> <th>Acc. Qty</th> </tr> </thead> <tbody> <tr> <td><math>\phi \leq 0.10</math></td> <td>Ignore</td> </tr> <tr> <td><math>0.10 &lt; \phi \leq 0.15</math></td> <td>2</td> </tr> <tr> <td><math>0.15 &lt; \phi \leq 0.25</math></td> <td>1</td> </tr> <tr> <td><math>0.25 &lt; \phi</math></td> <td>0</td> </tr> <tr> <td><b>Total</b></td> <td><b>2 no include <math>\phi \leq 0.10</math></b></td> </tr> </tbody> </table> <p><b>Distance between 2 defects should more than 3mm apart.</b></p>	Size \ Area	Acc. Qty	$\phi \leq 0.10$	Ignore	$0.10 < \phi \leq 0.15$	2	$0.15 < \phi \leq 0.25$	1	$0.25 < \phi$	0	<b>Total</b>	<b>2 no include <math>\phi \leq 0.10</math></b>						
Size \ Area	Acc. Qty																			
$\phi \leq 0.10$	Ignore																			
$0.10 < \phi \leq 0.15$	2																			
$0.15 < \phi \leq 0.25$	1																			
$0.25 < \phi$	0																			
<b>Total</b>	<b>2 no include <math>\phi \leq 0.10</math></b>																			
02	Electrical Defect (Minor defect)	<table border="1" data-bbox="478 1467 1300 1691"> <thead> <tr> <th></th> <th>Display Area</th> <th>Total</th> <th rowspan="3">Note1</th> </tr> </thead> <tbody> <tr> <td>Bright dot</td> <td>0</td> <td>0</td> </tr> <tr> <td>Dark dot</td> <td><math>N \leq 2</math></td> <td><math>N \leq 2</math></td> </tr> <tr> <td><b>Total dot</b></td> <td><math>N \leq 2</math></td> <td><math>N \leq 2</math></td> <td></td> </tr> <tr> <td><b>Mura</b></td> <td colspan="2"><b>Not visible through 5% ND filters.</b></td> <td><b>Note2</b></td> </tr> </tbody> </table> <p><b>Remark:</b>                      1. Bright dot caused by scratch and foreign object accords to item 1.</p>		Display Area	Total	Note1	Bright dot	0	0	Dark dot	$N \leq 2$	$N \leq 2$	<b>Total dot</b>	$N \leq 2$	$N \leq 2$		<b>Mura</b>	<b>Not visible through 5% ND filters.</b>		<b>Note2</b>
	Display Area	Total	Note1																	
Bright dot	0	0																		
Dark dot	$N \leq 2$	$N \leq 2$																		
<b>Total dot</b>	$N \leq 2$	$N \leq 2$																		
<b>Mura</b>	<b>Not visible through 5% ND filters.</b>		<b>Note2</b>																	

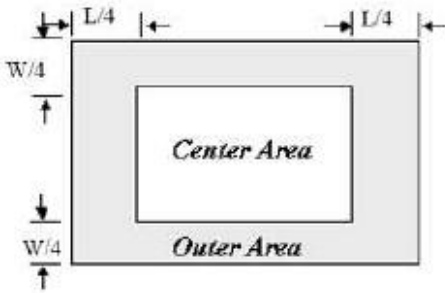
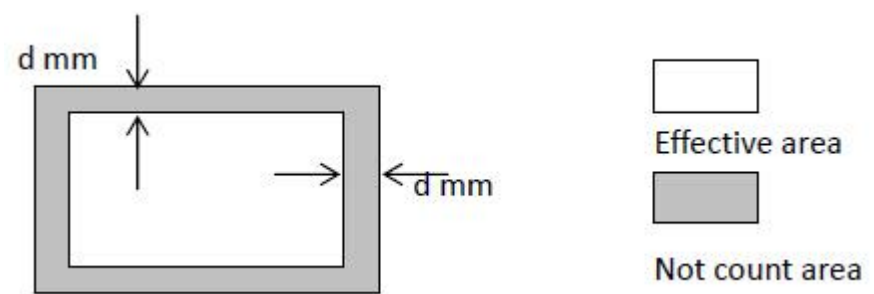
03	Inactive Area (Minor defect)	<p>Line Criteria: <math>L \leq 1\text{mm}</math>, <math>W \leq 0.1\text{mm}</math>, Dot Criteria: Please refer to Note 1,2&amp;3 <b>Note1:</b> Definition of Area</p>  <p><b>Note2:</b></p> <table border="1" data-bbox="478 728 1404 1108"> <thead> <tr> <th>尺寸</th> <th>缺圖</th> <th>中心 Center</th> <th>外圍 Outer</th> <th>總數 Total</th> <th>備註</th> </tr> </thead> <tbody> <tr> <td>All</td> <td><math>\varnothing &lt; 0.2\text{mm}</math>;</td> <td colspan="4" style="text-align: center;">不計數</td> </tr> <tr> <td>&lt;6°</td> <td><math>0.2 \leq \varnothing \leq 0.3\text{mm}</math>; <math>L \leq 1\text{mm}, W \leq 0.1\text{mm}</math></td> <td><math>N \leq 1</math></td> <td><math>N \leq 2</math></td> <td><math>N \leq 3</math></td> <td></td> </tr> <tr> <td>6~8°</td> <td><math>0.2 \leq \varnothing \leq 0.5\text{mm}</math>; <math>L \leq 1\text{mm}, W \leq 0.1\text{mm}</math></td> <td><math>N \leq 2</math></td> <td><math>N \leq 3</math></td> <td><math>N \leq 5</math></td> <td><math>0.4 \leq \varnothing \leq 0.5\text{mm}, N \leq 1</math> is allowed at outer.)</td> </tr> <tr> <td>8.1°~10.1°</td> <td><math>0.2 \leq \varnothing \leq 0.5\text{mm}</math>; <math>L \leq 1\text{mm}, W \leq 0.1\text{mm}</math></td> <td><math>N \leq 2</math></td> <td><math>N \leq 5</math></td> <td><math>N \leq 7</math></td> <td><math>0.4 \leq \varnothing \leq 0.5\text{mm}, N \leq 2</math> is allowed at outer.)</td> </tr> <tr> <td>10.2°~15°</td> <td><math>0.2 \leq \varnothing \leq 0.5\text{mm}</math>; <math>L \leq 1\text{mm}, W \leq 0.1\text{mm}</math></td> <td><math>N \leq 5</math></td> <td><math>N \leq 10</math></td> <td><math>N \leq 15</math></td> <td><math>(0.4 \leq \varnothing \leq 0.5\text{mm}, N \leq 5</math> is allowed at outer.)</td> </tr> </tbody> </table> <p><b>Note3:</b> Inactive area <math>D &lt; 0.2\text{mm}</math> is not counted without appearance observation. <b>Remark:</b> Effective area is from the POL cutting side to 0.5mm of inside. This is no count area. Other part is effective area. In no count area, any defect can ignore. In effective area, have to judge from above-mentioned specification.</p> 	尺寸	缺圖	中心 Center	外圍 Outer	總數 Total	備註	All	$\varnothing < 0.2\text{mm}$ ;	不計數				<6°	$0.2 \leq \varnothing \leq 0.3\text{mm}$ ; $L \leq 1\text{mm}, W \leq 0.1\text{mm}$	$N \leq 1$	$N \leq 2$	$N \leq 3$		6~8°	$0.2 \leq \varnothing \leq 0.5\text{mm}$ ; $L \leq 1\text{mm}, W \leq 0.1\text{mm}$	$N \leq 2$	$N \leq 3$	$N \leq 5$	$0.4 \leq \varnothing \leq 0.5\text{mm}, N \leq 1$ is allowed at outer.)	8.1°~10.1°	$0.2 \leq \varnothing \leq 0.5\text{mm}$ ; $L \leq 1\text{mm}, W \leq 0.1\text{mm}$	$N \leq 2$	$N \leq 5$	$N \leq 7$	$0.4 \leq \varnothing \leq 0.5\text{mm}, N \leq 2$ is allowed at outer.)	10.2°~15°	$0.2 \leq \varnothing \leq 0.5\text{mm}$ ; $L \leq 1\text{mm}, W \leq 0.1\text{mm}$	$N \leq 5$	$N \leq 10$	$N \leq 15$	$(0.4 \leq \varnothing \leq 0.5\text{mm}, N \leq 5$ is allowed at outer.)
		尺寸	缺圖	中心 Center	外圍 Outer	總數 Total	備註																															
All	$\varnothing < 0.2\text{mm}$ ;	不計數																																				
<6°	$0.2 \leq \varnothing \leq 0.3\text{mm}$ ; $L \leq 1\text{mm}, W \leq 0.1\text{mm}$	$N \leq 1$	$N \leq 2$	$N \leq 3$																																		
6~8°	$0.2 \leq \varnothing \leq 0.5\text{mm}$ ; $L \leq 1\text{mm}, W \leq 0.1\text{mm}$	$N \leq 2$	$N \leq 3$	$N \leq 5$	$0.4 \leq \varnothing \leq 0.5\text{mm}, N \leq 1$ is allowed at outer.)																																	
8.1°~10.1°	$0.2 \leq \varnothing \leq 0.5\text{mm}$ ; $L \leq 1\text{mm}, W \leq 0.1\text{mm}$	$N \leq 2$	$N \leq 5$	$N \leq 7$	$0.4 \leq \varnothing \leq 0.5\text{mm}, N \leq 2$ is allowed at outer.)																																	
10.2°~15°	$0.2 \leq \varnothing \leq 0.5\text{mm}$ ; $L \leq 1\text{mm}, W \leq 0.1\text{mm}$	$N \leq 5$	$N \leq 10$	$N \leq 15$	$(0.4 \leq \varnothing \leq 0.5\text{mm}, N \leq 5$ is allowed at outer.)																																	

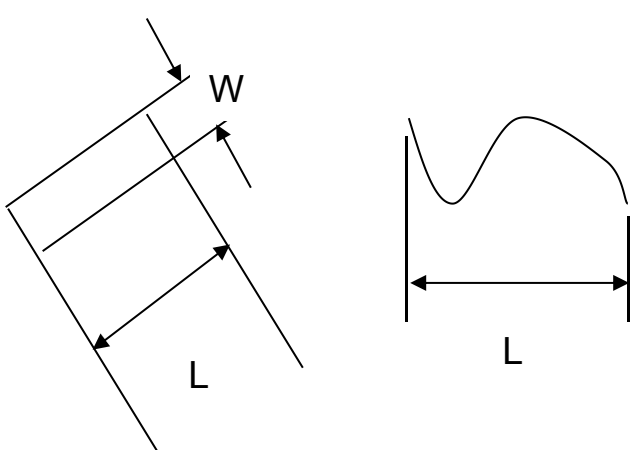
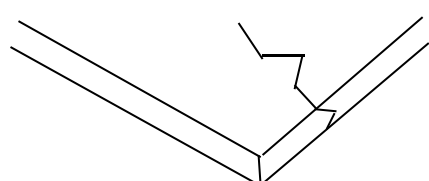
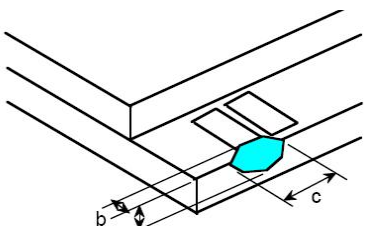
04	<p>Black and White line Scratch Foreign material (Line type) (Minor defect)</p>	 <table border="1" data-bbox="526 739 1165 1052"> <thead> <tr> <th>Length</th> <th>Width</th> <th>Acc. Qty</th> </tr> </thead> <tbody> <tr> <td>/</td> <td><math>W \leq 0.03</math></td> <td>Ignore</td> </tr> <tr> <td><math>L \leq 2.5</math></td> <td><math>0.03 &lt; W \leq 0.05</math></td> <td>3</td> </tr> <tr> <td><math>L \leq 2.5</math></td> <td><math>0.05 &lt; W \leq 0.10</math></td> <td>2</td> </tr> <tr> <td>/</td> <td><math>0.1 &lt; W</math></td> <td>0</td> </tr> <tr> <td colspan="2">Total</td> <td>3</td> </tr> </tbody> </table> <p>Distance between 2 defects should more than 3mm apart. Scratches not viewable through the back of the display are acceptable.</p>	Length	Width	Acc. Qty	/	$W \leq 0.03$	Ignore	$L \leq 2.5$	$0.03 < W \leq 0.05$	3	$L \leq 2.5$	$0.05 < W \leq 0.10$	2	/	$0.1 < W$	0	Total		3
Length	Width	Acc. Qty																		
/	$W \leq 0.03$	Ignore																		
$L \leq 2.5$	$0.03 < W \leq 0.05$	3																		
$L \leq 2.5$	$0.05 < W \leq 0.10$	2																		
/	$0.1 < W$	0																		
Total		3																		
05	<p>Glass Crack (Minor defect)</p>	 <p>Crack is potential to enlarge, any type is not allowed.</p>																		
06	<p>Glass Chipping Pad Area: (Minor defect)</p> 	<table border="1" data-bbox="861 1680 1340 1859"> <thead> <tr> <th>Length and Width</th> <th>Acc. Qty</th> </tr> </thead> <tbody> <tr> <td><math>c &gt; 3.0, b &lt; 1.0</math></td> <td>1</td> </tr> <tr> <td><math>c &lt; 3.0, b &lt; 1.0</math></td> <td>3</td> </tr> <tr> <td colspan="2"><math>a &lt; \text{Glass Thickness}</math></td> </tr> </tbody> </table>	Length and Width	Acc. Qty	$c > 3.0, b < 1.0$	1	$c < 3.0, b < 1.0$	3	$a < \text{Glass Thickness}$											
Length and Width	Acc. Qty																			
$c > 3.0, b < 1.0$	1																			
$c < 3.0, b < 1.0$	3																			
$a < \text{Glass Thickness}$																				

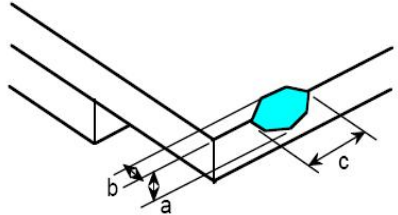
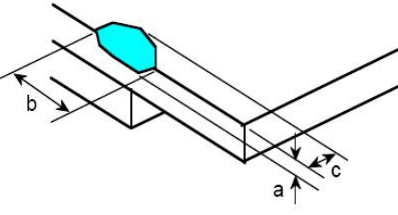
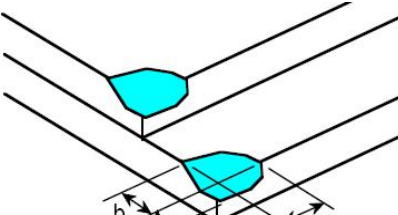
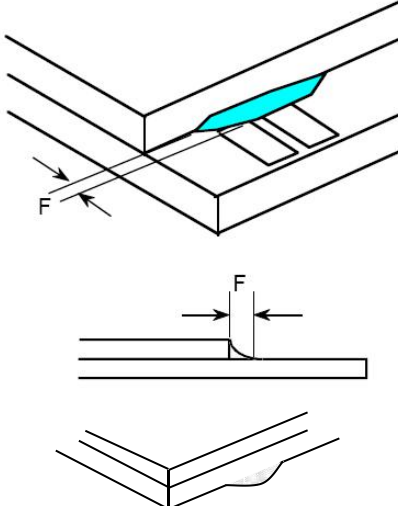
<p>07</p>	<p>Glass Chipping Rear of Pad Area: (Minor defect)</p> 	<table border="1"> <thead> <tr> <th>Length and Width</th> <th>Acc. Qty</th> </tr> </thead> <tbody> <tr> <td><math>c &gt; 3.0, b &lt; 1.0</math></td> <td>1</td> </tr> <tr> <td><math>c &lt; 3.0, b &lt; 1.0</math></td> <td>2</td> </tr> <tr> <td><math>c &lt; 3.0, b &lt; 0.5</math></td> <td>4</td> </tr> <tr> <td colspan="2" style="text-align: center;"><math>a &lt; \text{Glass Thickness}</math></td> </tr> </tbody> </table>	Length and Width	Acc. Qty	$c > 3.0, b < 1.0$	1	$c < 3.0, b < 1.0$	2	$c < 3.0, b < 0.5$	4	$a < \text{Glass Thickness}$	
Length and Width	Acc. Qty											
$c > 3.0, b < 1.0$	1											
$c < 3.0, b < 1.0$	2											
$c < 3.0, b < 0.5$	4											
$a < \text{Glass Thickness}$												
<p>08</p>	<p>Glass Chipping Except Pad Area: (Minor defect)</p> 	<table border="1"> <thead> <tr> <th>Length and Width</th> <th>Acc. Qty</th> </tr> </thead> <tbody> <tr> <td><math>c &gt; 3.0, b &lt; 1.0</math></td> <td>1</td> </tr> <tr> <td><math>c &lt; 3.0, b &lt; 1.0</math></td> <td>2</td> </tr> <tr> <td><math>c &lt; 3.0, b &lt; 0.5</math></td> <td>4</td> </tr> <tr> <td colspan="2" style="text-align: center;"><math>a &lt; \text{Glass Thickness}</math></td> </tr> </tbody> </table>	Length and Width	Acc. Qty	$c > 3.0, b < 1.0$	1	$c < 3.0, b < 1.0$	2	$c < 3.0, b < 0.5$	4	$a < \text{Glass Thickness}$	
Length and Width	Acc. Qty											
$c > 3.0, b < 1.0$	1											
$c < 3.0, b < 1.0$	2											
$c < 3.0, b < 0.5$	4											
$a < \text{Glass Thickness}$												
<p>09</p>	<p>Glass Corner Chipping: (Minor defect)</p> 	<table border="1"> <thead> <tr> <th>Length and Width</th> <th>Acc. Qty</th> </tr> </thead> <tbody> <tr> <td><math>c &lt; 3.0, b &lt; 3.0</math></td> <td>Ignore</td> </tr> <tr> <td colspan="2" style="text-align: center;"><math>a &lt; \text{Glass Thickness}</math></td> </tr> </tbody> </table>	Length and Width	Acc. Qty	$c < 3.0, b < 3.0$	Ignore	$a < \text{Glass Thickness}$					
Length and Width	Acc. Qty											
$c < 3.0, b < 3.0$	Ignore											
$a < \text{Glass Thickness}$												
<p>10</p>	<p>Glass Burr: (Minor defect)</p> 	<table border="1"> <thead> <tr> <th>Length</th> <th>Acc. Qty</th> </tr> </thead> <tbody> <tr> <td><math>F &lt; 1.0</math></td> <td>Ignore</td> </tr> </tbody> </table> <p>Glass burr don't affect assemble and module dimension.</p>	Length	Acc. Qty	$F < 1.0$	Ignore						
Length	Acc. Qty											
$F < 1.0$	Ignore											

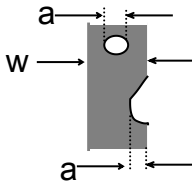
11	<p>FPC Defect: (Minor defect)</p> 	<p>11.1 Dent, pinhole width <math>a &lt; w/3</math>. (<math>w</math>: circuitry width.) 11.2 Open circuit is unacceptable. 11.3 No oxidation, contamination and distortion.</p>										
12	Bubble on Polarizer (Minor defect)	<table border="1" data-bbox="743 595 1214 808"> <thead> <tr> <th>Diameter</th> <th>Acc. Qty</th> </tr> </thead> <tbody> <tr> <td><math>\varphi \leq 0.20</math></td> <td>Ignore</td> </tr> <tr> <td><math>0.20 &lt; \varphi \leq 0.30</math></td> <td>4</td> </tr> <tr> <td><math>0.30 &lt; \varphi \leq 0.50</math></td> <td>1</td> </tr> <tr> <td><math>0.50 &lt; \varphi</math></td> <td>None</td> </tr> </tbody> </table>	Diameter	Acc. Qty	$\varphi \leq 0.20$	Ignore	$0.20 < \varphi \leq 0.30$	4	$0.30 < \varphi \leq 0.50$	1	$0.50 < \varphi$	None
Diameter	Acc. Qty											
$\varphi \leq 0.20$	Ignore											
$0.20 < \varphi \leq 0.30$	4											
$0.30 < \varphi \leq 0.50$	1											
$0.50 < \varphi$	None											
13	Dent on Polarizer (Minor defect)	<table border="1" data-bbox="743 871 1214 1084"> <thead> <tr> <th>Diameter</th> <th>Acc. Qty</th> </tr> </thead> <tbody> <tr> <td><math>\varphi \leq 0.20</math></td> <td>Ignore</td> </tr> <tr> <td><math>0.20 &lt; \varphi \leq 0.30</math></td> <td>4</td> </tr> <tr> <td><math>0.30 &lt; \varphi \leq 0.50</math></td> <td>1</td> </tr> <tr> <td><math>0.50 &lt; \varphi</math></td> <td>None</td> </tr> </tbody> </table>	Diameter	Acc. Qty	$\varphi \leq 0.20$	Ignore	$0.20 < \varphi \leq 0.30$	4	$0.30 < \varphi \leq 0.50$	1	$0.50 < \varphi$	None
Diameter	Acc. Qty											
$\varphi \leq 0.20$	Ignore											
$0.20 < \varphi \leq 0.30$	4											
$0.30 < \varphi \leq 0.50$	1											
$0.50 < \varphi$	None											
14	Bezel	<p>14.1 No rust, distortion on the Bezel. 14.2 No visible fingerprints, stains or other contamination.</p>										
15	Touch Panel	<p>D: Diameter W: width L: length 15.1 Spot: <math>D &lt; 0.25</math> is acceptable <math>0.25 \leq D \leq 0.4</math> 2dots are acceptable and the distance between defects should more than 10 mm. <math>D &gt; 0.4</math> is unacceptable 15.2 Dent: <math>D &gt; 0.40</math> is unacceptable 15.3 Scratch: <math>W \leq 0.03</math>, <math>L \leq 10</math> is acceptable, <math>0.03 &lt; W \leq 0.10</math>, <math>L \leq 10</math> is acceptable Distance between 2 defects should more than 10 mm. <math>W &gt; 0.10</math> is unacceptable.</p>										
16	PCB	<p>16.1 No distortion or contamination on PCB terminals. 16.2 All components on PCB must same as documented on the BOM/component layout. 17.3 Follow IPC-A-600F.</p>										

17	Soldering	Follow IPC-A-610C standard
18	Electrical Defect (Major defect)	<p>The below defects must be rejected.</p> <p>18.1 Missing vertical / horizontal segment, 18.2 Abnormal Display. 18.3 No function or no display. 18.4 Current exceeds product specifications. 18.5 LCD viewing angle defect. 18.6 No Backlight. 18.7 Dark Backlight. 18.8 Touch Panel no function.</p>

Remark: LCD Panel Broken shall be rejected. Defect out of LCD viewing area is acceptable.

### 10.7. Classification of Defects

10.7.1 Visual defects (Except no / wrong label) are treated as minor defect and electrical defect is major.

10.7.2 Two minor defects are equal to one major in lot sampling inspection.

### 10.8. Identification/marketing criteria

Any unit with illegible / wrong /double or no marking/ label shall be rejected.

### 10.9. Packaging

10.9.1 There should be no damage of the outside carton box, each packaging box should have one identical label.

10.9.2 Modules inside package box should have compliant mark.

10.9.3 All direct package materials shall offer ESD protection

**Note1:** Bright dot is defined as the defective area of the dot is larger than 50% of one sub-pixel area.

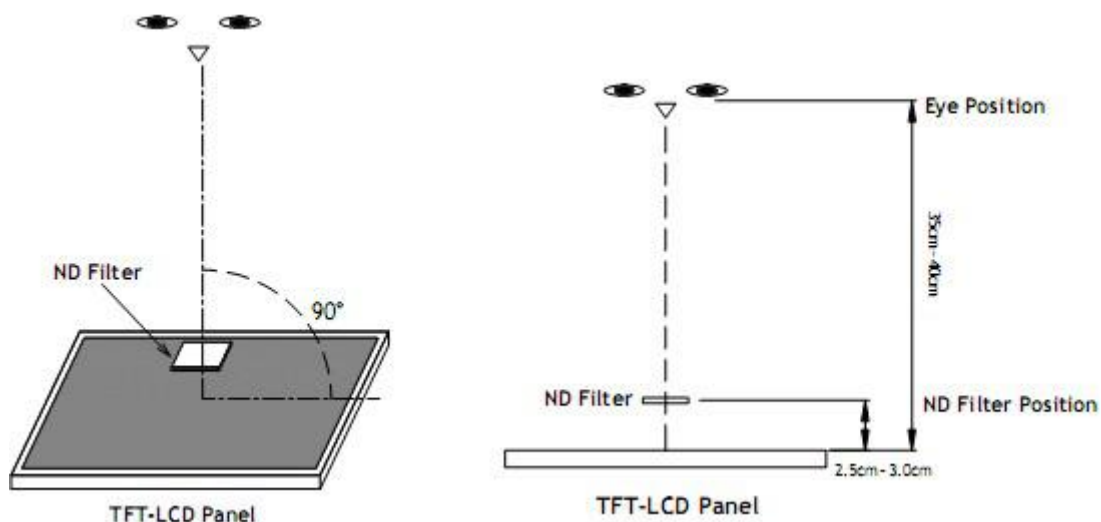

**Bright dot:** The bright dot size defect at black display pattern. It can be recognized by 2% transparency of filter when the distance between eyes and panel is  $350\text{mm} \pm 50\text{mm}$ .

**Dark dot:** Cyan, Magenta or Yellow dot size defect at white display pattern. It can be recognized by 5% transparency of filter when the distance between eyes and panel is  $350\text{mm} \pm 50\text{mm}$ .

**Note2:** Mura on display which appears darker / brighter against background brightness on parts of display area.

## 11. Reliability Specification

No	Item	Condition	Quantity	Criteria
1	High Temperature Operating	<b>70°C, 96Hrs</b>	2	GB/T2423.2-2008
2	Low Temperature Operating	<b>-20°C, 96Hrs</b>	2	GB/T2423.1-2008
3	High Humidity	<b>50°C, 90%RH, 96Hrs</b>	2	GB/T2423.3-2006
4	High Temperature Storage	<b>80°C, 96Hrs</b>	2	GB/T2423.2-2008
5	Low Temperature Storage	<b>-30°C, 96Hrs</b>	2	GB/T2423.1-2008
6	Thermal Cycling Test	-20°C, 60min~70°C, 60min, 20 cycles.	2	GB/T2423.22-2012
7	Packing vibration	Frequency range:10Hz~50Hz Acceleration of gravity:5G X, Y, Z 30 min for each direction.	2	GB/T5170.14-2009
8	Electrical Static Discharge	Air: ±8KV 150pF/330 Ω 5 times Contact: ±4KV 150pF/330 Ω 5 times	2	GB/T17626.2-2006
9	Drop Test (Packaged)	Height:80 cm,1 corner, 3 edges, 6 surfaces.	2	GB/T2423.8-1995

Note1. No deflection cosmetic and operational function allowable.

Note2. Total current Consumption should be below double of initial value

## 12. Precautions and Warranty

### 12.1. Safety

- 12.1.1. The liquid crystal in the LCD is poisonous. Do not put it in your mouth. If the liquid crystal touches your skin or clothes, wash it off immediately using soap and water.
- 12.1.2. Since the liquid crystal cells are made of glass, do not apply strong impact on them. Handle with care.

### 12.2. Handling

- 12.2.1. Reverse and use within ratings in order to keep performance and prevent damage.
- 12.2.2. Do not wipe the polarizer with dry cloth, as it might cause scratch. If the surface of the LCD needs to be cleaned, wipe it swiftly with cotton or other soft cloth soaked with petroleum IPA, do not use other chemicals.

### 12.3. Storage

- 12.3.1. Do not store the LCD module beyond the specified temperature ranges.
- 12.3.2. Strong light exposure causes degradation of polarizer and color filter

### 12.4. Metal Pin (Apply to Products with Metal Pins)

#### 12.4.1. Pins of LCD and Backlight

12.4.1.1. Solder tip can touch and press on the tip of Pin LEAD during the soldering

#### 12.4.1.2. Recommended Soldering Conditions

Solder Type: Sn96.3~94-Ag3.3~4.3-Cu0.4~1.1

Maximum Solder Temperature: 370 °C

Maximum Solder Time: 3s at the maximum temperature

Recommended Soldering Temp: 350±20 °C

Typical Soldering Time: ≤3s

#### 12.4.1.3. Solder Wetting

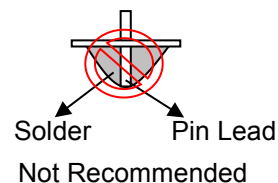
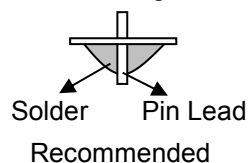

#### 12.4.2. Pins of EL

12.4.2.1. Solder tip can touch and press on the tip of EL leads during soldering.

12.4.2.2. No Solder Paste on the soldering pad on the motherboard is recommended.

#### 12.4.2.3. Recommended Soldering Conditions

Solder type: Nippon Alimit Leadfree SR-34, size 0.5mm

Recommended Solder Temperature: 270~290 °C

Typical Soldering Time: ≤2s

Minimum solder distance from EL lamp (body):2.0mm

12.4.2.4. No horizontal press on the EL leads during soldering.

12.4.2.5. 180° bend EL leads three times is not allowed.



#### 12.4.2.6. Solder Wetting



#### 12.4.2.7. The type of the solder iron:



#### 12.4.2.8. Solder Pad

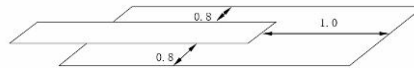

### 12.5. Operation

- 12.5.1. Do not drive LCD with DC voltage
- 12.5.2. Response time will increase below lower temperature
- 12.5.3. Display may change color with different temperature
- 12.5.4. Mechanical disturbance during operation, such as pressing on the display area, may cause the segments to appear "fractured".
- 12.5.5. Do not connect or disconnect the LCM to or from the system when power is on.
- 12.5.6. Never use the LCM under abnormal condition of high temperature and high humidity.
- 12.5.7. Module has high frequency circuits. Sufficient suppression to the electromagnetic interface shall be done by system manufacturers. Grounding and shielding methods may be important to minimize the interference.
- 12.5.8. Do not display the fixed pattern for long time (we suggest the time not longer than one hour) because it may develop image sticking due to the TFT structure.

### 12.6. Static Electricity

- 12.6.1. CMOS LSIs are equipped in this unit, so care must be taken to avoid the electro-static charge, by ground human body, etc.
- 12.6.2. The normal static prevention measures should be observed for work clothes and benches.
- 12.6.3. The module should be kept into anti-static bags or other containers resistant to static for storage.

### 12.7. Limited Warranty

- 12.7.1. Our warranty liability is limited to repair and/or replacement. We will not be responsible for any consequential loss.
- 12.7.2. If possible, we suggest customer to use up all modules in six months. If the module storage time over twelve months, we suggest that recheck it before the module be used
- 12.7.3. After the product shipped, any product quality issues must be feedback within three months, otherwise, we will not be responsible for the subsequent or consequential events.

### 13. Packaging

TBD

14. Outline Drawing

