



PRODUCT SPECIFICATION

3.5" MVA TFT LCD MODULE

MODEL: T035320240-A2MMN-001 Ver:2.0

ROHS

< ◇ > Preliminary Specification

< ◆ > Finally Specification

CUSTOMER'S APPROVAL	
CUSTOMER :	
SIGNATURE:	DATE:

APPROVED BY	PM REVIEWED	PD REVIEWED	PREPARED BY

Revision History

Revision	Date	Originator	Detail	Remarks
1.0	2013.09.23		Initial Release	
1.1	2013.11.21		Modify Reliability Specification Modify Outline Drawing	P23 P27
1.2	2013.11.30		Modify Chromaticity Transmissive	P6
1.3	2014.04.24		Modify Display Colors Modify Inspection Specification Modify Reliability Specification	P4 P19 P24
1.4	2014.08.28		Add Weight Add Consumption Modify Backlight Characteristics Modify Inspection Specification	P4 P5 P5,29 P20,23
1.5	2014.09.29		Modify AC Characteristics	P13
1.6	2015.10.30	CGP	Modify Optical Characteristics	P6
1.7	2016.10.31	ZFY	Modify current	P5
1.8	2018.04.19	ZDT	Modify LED working life Modify many details	P5 P27-P28
1.9	2018.10.18	WQ	Modify Outline Drawing	P30
2.0	2018.11.30	ZDT	Modify Luminance on TFT Modify Outline Drawing(D)	P6 P30

Table of Contents

No.	Item	Page
1.	General Description.....	4
2.	Module Parameter.....	4
3.	Absolute Maximum Ratings.....	4
4.	DC Characteristics.....	5
5.	Backlight Characteristic.....	5
5.1.	Backlight Characteristics.....	5
5.2.	Backlighting circuit.....	5
6.	Optical Characteristics.....	6
6.1.	Optical Characteristics.....	6
6.2.	Definition of Response Time.....	6
6.3.	Definition of Contrast Ratio.....	7
6.4.	Definition of Viewing Angles.....	7
6.5.	Definition of Color Appearance.....	8
6.6.	Definition of Surface Luminance, Uniformity and Transmittance.....	8
7.	Block Diagram and Power Supply.....	9
8.	Interface Pins Definition.....	10
9.	AC Characteristics.....	11
10.	Quality Assurance.....	18
10.1.	Purpose.....	18
10.2.	Standard for Quality Test.....	18
10.3.	Nonconforming Analysis & Disposition.....	18
10.4.	Agreement Items.....	18
10.5.	Standard of the Product Visual Inspection.....	18
10.6.	Inspection Specification.....	19
10.7.	Classification of Defects.....	24
10.8.	Identification/marketing criteria.....	24
10.9.	Packing.....	24
11.	Reliability Specification.....	26
12.	Precautions and Warranty.....	27
12.1.	Safety.....	27
12.2.	Handling.....	27
12.3.	Storage.....	27
12.4.	Metal Pin (Apply to Products with Metal Pins).....	27
12.5.	Operation.....	28
12.6.	Static Electricity.....	28
12.7.	Limited Warranty.....	28
13.	Packaging.....	29
14.	Outline Drawing.....	30

1. General Description

The specification is a transmissive type color active matrix liquid crystal display (LCD) which uses amorphous thin film transistor (TFT) as switching devices. This product is composed of a TFT-LCD panel, driver ICs and a backlight unit.

2. Module Parameter

Features	Details	Unit
Display Size(Diagonal)	3.5"	
LCD type	MVA TFT	
Display Mode	Transmissive /Normally white	
Resolution	320 RGB x 240	Pixels
View Direction	FULL VIEW	Best Image
Module Outline	76.9(H) x 63.9(V) x 3.2(T) (Note1)	mm
Active Area	70.08(H) x 52.56(V)	mm
Pixel Size	219(H) x219(V)	um
Pixel Arrangement	RGB stripe	
Polarizer Surface Treatment	Anti-glare	
Display Colors	16.7M	
Interface	24-bit RGB Interface+3 wire SPI	
Driver IC	HX8238D	-
With or Without Touch Panel	Without	
Operating Temperature	-20~70	°C
Storage Temperature	-30~80	°C
Weight	32	g

Note 1: Exclusive hooks, posts, FFC/FPC tail etc.

3. Absolute Maximum Ratings

V_{SS}=0V, Ta=25°C

Item	Symbol	Min.	Max.	Unit
Supply Voltage	VDD	-0.3	5.0	V
Storage temperature	T _{stg}	-30	+80	°C
Operating temperature	T _{op}	-20	+70	°C

Note 1: If Ta below 50°C, the maximal humidity is 90%RH, if Ta over 50°C, absolute humidity should be less than 60%RH.

Note 2: The response time will be extremely slow when the operating temperature is around -10°C, and the back ground will become darker at high temperature operating.

4. DC Characteristics

Item	Symbol	Min.	Typ.	Max.	Unit	
Supply Voltage	VDD	3.0	3.3	3.6	V	
Logic Low input voltage	V _{IL}	GND	-	0.2*VDD	V	
Logic High input voltage	V _{IH}	0.8*VDD	-	VDD	V	
Logic Low output voltage	V _{OL}	GND	-	0.1*VDD	V	
Logic High output voltage	V _{OH}	0.9*VDD	-	VDD	V	
Current Consumption All Black	Logic	-	-	15	30	mA
	Analog					

5. Backlight Characteristic

5.1. Backlight Characteristics

Item	Symbol	Condition	Min.	Typ.	Max.	Unit
Forward Voltage	V _F	Ta=25 °C, I _F =20mA/LED	16.8	19.2	20.4	V
Forward Current	I _F	Ta=25 °C, V _F =3.2V/LED	-	20	-	mA
Power dissipation	P _d		-	384	-	mW
Uniformity	Avg		80	85	-	%
LED working life(25°C)	-		-	30,000	-	Hrs
Drive method	Constant current					
LED Configuration	6 White LEDs in series					

Note: LED life time defined as follows: The final brightness is at 50% of original brightness.

The environmental conducted under ambient air flow, at Ta=25±2 °C,60%RH±5%, I_F=20mA/LED.

5.2. Backlighting circuit

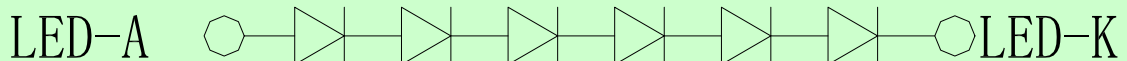

6. Optical Characteristics

6.1. Optical Characteristics

Ta=25°C, V_{DD}=3.3V

	Item	Symbol	Condition	Specification			Unit	
				Min.	Typ.	Max.		
Backlight On (Transmissive Mode)	Luminance on TFT(I _f =20mA/LED)	Lv	Normally viewing angle θ _X = φ _Y = 0°	260	320	-	cd/m ²	
	Contrast ratio(See 6.3)	CR		300	350	-		
	Response time (See 6.2)	TR+TF		-	25	40	ms	
	Chromaticity Transmissive (See 6.5)	Red	X _R	Center CR≥10	0.539	0.579	0.639	
			Y _R		0.281	0.331	0.381	
		Green	X _G		0.264	0.314	0.364	
			Y _G		0.566	0.616	0.666	
		Blue	X _B		0.092	0.142	0.192	
			Y _B		0.042	0.092	0.142	
	White	X _W	0.239	0.279	0.339			
		Y _W	0.282	0.332	0.382			
	Viewing Angle (See 6.4)	Horizontal	θ _{X+}	Center CR≥10	60	75	-	Deg.
			θ _{X-}		60	75	-	
Vertical		φ _{Y+}	60		75	-		
		φ _{Y-}	60		75	-		
NTSC Ratio(Gamut)				-	53	-	%	

6.2. Definition of Response Time

6.2.1. Normally Black Type (Negative)

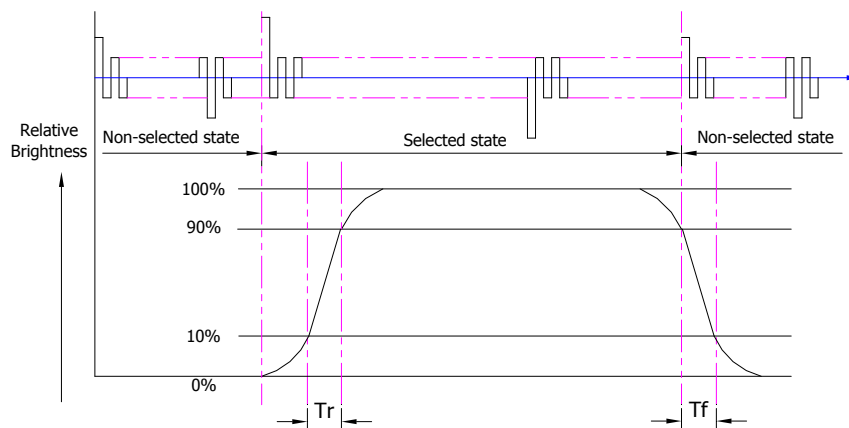

Tr is the time it takes to change from non-selected state with relative luminance 10% to selected state with relative luminance 90%;

Tf is the time it takes to change from selected state with relative luminance 90% to

non-selected state with relative luminance 10%.

Note: Measuring machine: LCD-5100

6.2.2. Normally White Type (Positive)

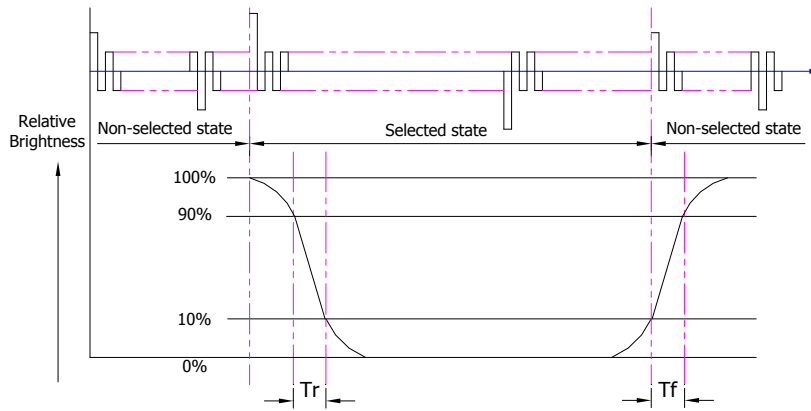

Tr is the time it takes to change from non-selected state with relative luminance 90% to selected state with relative luminance 10%;

Tf is the time it takes to change from selected state with relative luminance 10% to non-selected state with relative luminance 90%;

Note: Measuring machine: LCD-5100 or EQUI

6.3. Definition of Contrast Ratio

Contrast is measured perpendicular to display surface in reflective and transmissive mode.

The measurement condition is:

Measuring Equipment	Eldim or Equivalent
Measuring Point Diameter	3mm//1mm
Measuring Point Location	Active Area centre point
Test pattern	A: All Pixels white B: All Pixel black
Contrast setting	Maximum

Definitions: CR (Contrast) = Luminance of White Pixel / Luminance of Black Pixel

6.4. Definition of Viewing Angles

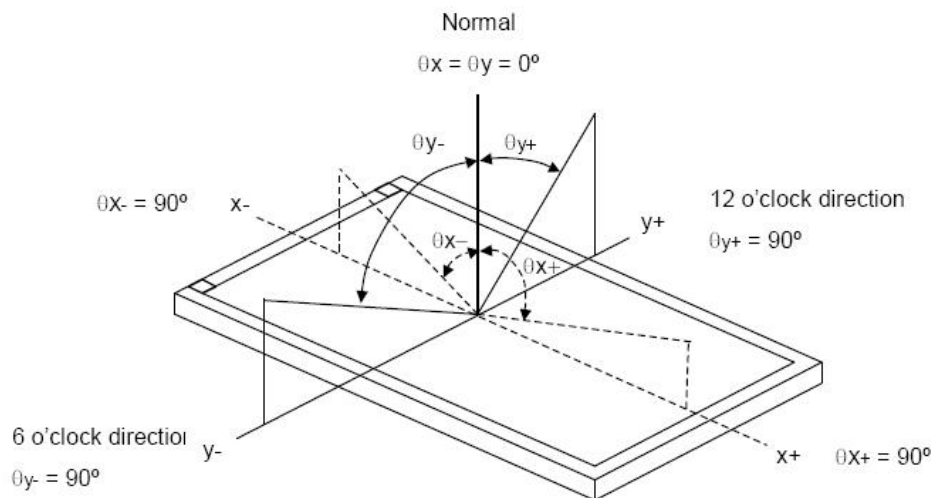

Measuring machine: LCD-5100 or EQUI

6.5. Definition of Color Appearance

R,G,B and W are defined by (x, y) on the IE chromaticity diagram

NTSC=area of RGB triangle/area of NTSC triangleX100%

Measuring picture: Red, Green, Blue and White (Measuring machine: BM-7)

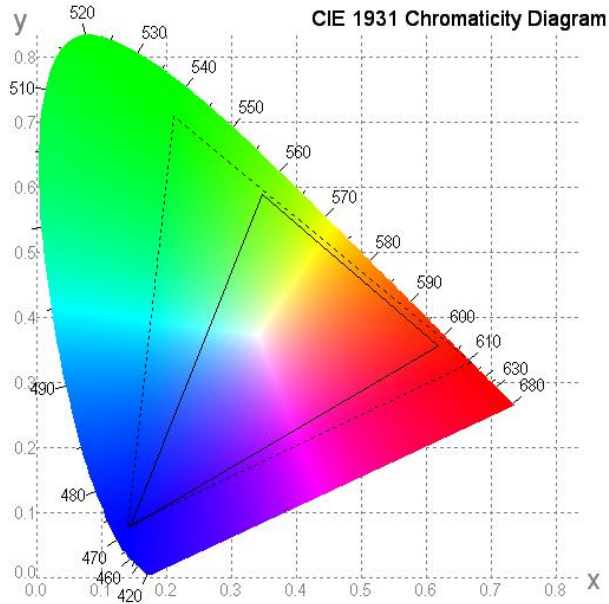

6.6. Definition of Surface Luminance, Uniformity and Transmittance

Using the transmissive mode measurement approach, measure the white screen luminance of the display panel and backlight.

6.6.1. Surface Luminance: $L_V = \text{average}(L_{P1}:L_{P9})$

6.6.2. Uniformity = Minimal ($L_{P1}:L_{P9}$) / Maximal ($L_{P1}:L_{P9}$) * 100%

6.6.3. Transmittance = L_V on LCD / L_V on Backlight * 100%

Note: Measuring machine: BM-7

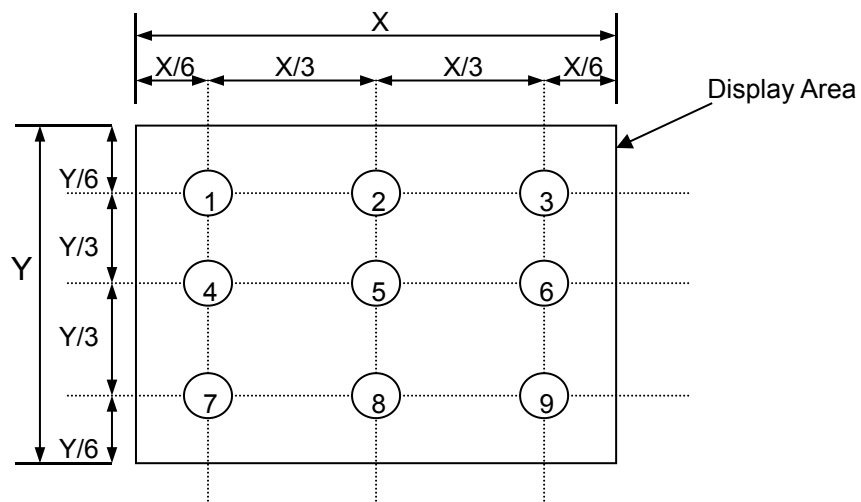

7. Block Diagram and Power Supply

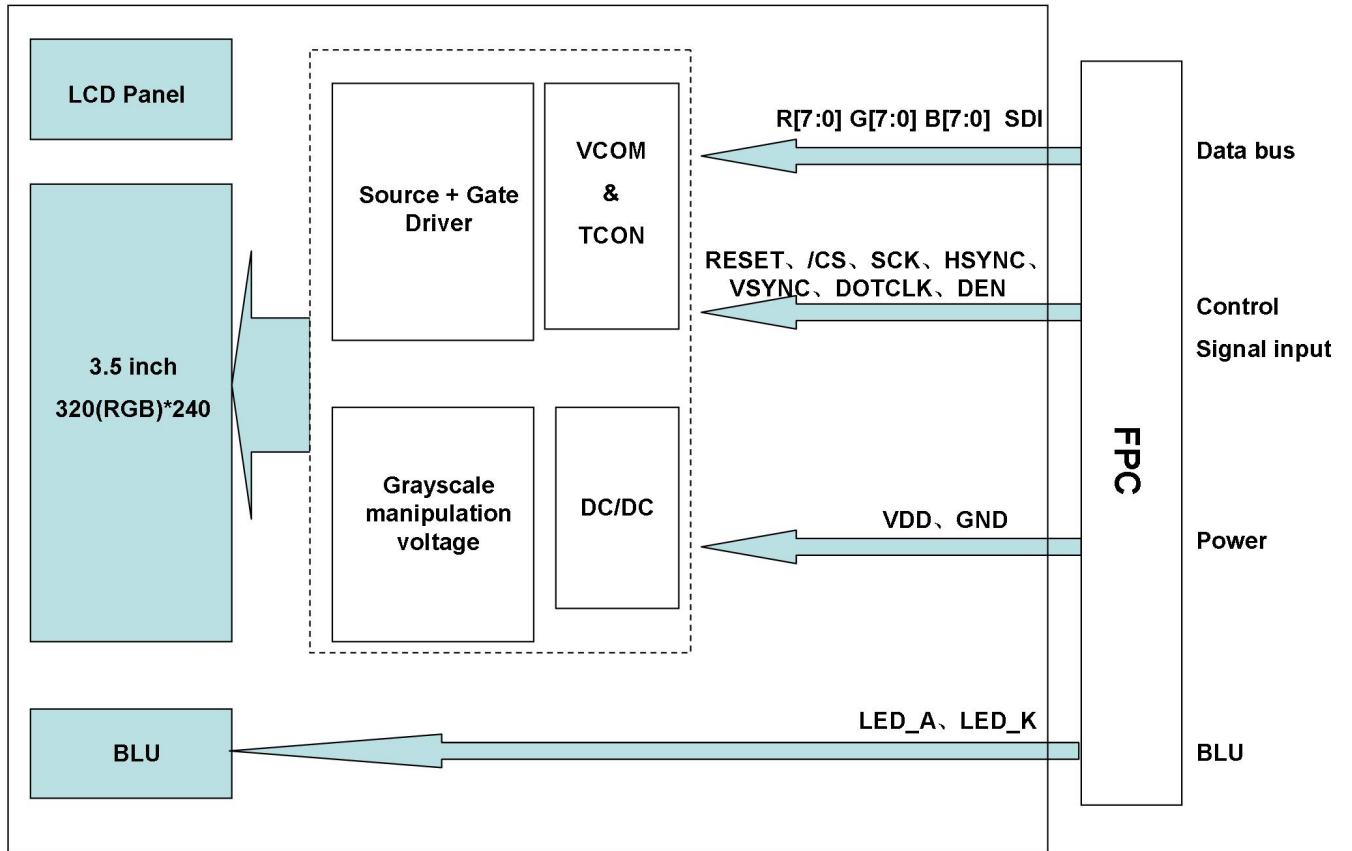

8. Interface Pins Definition

No.	Symbol	Function	Remark
1-2	LED_K	LED cathode	
3-4	LED_A	LED anode	
5-7	NC	No connect	
8	RESET	Reset signal, Low active	
9	/CS	Chip select	
10	SCK	SPI Serial Clock	
11	SDI	SPI Serial Data Input/output	
12	B0	Data bus	
13	B1	Data bus	
14	B2	Data bus	
15	B3	Data bus	
16	B4	Data bus	
17	B5	Data bus	
18	B6	Data bus	
19	B7	Data bus	
20	G0	Data bus	
21	G1	Data bus	
22	G2	Data bus	
23	G3	Data bus	
24	G4	Data bus	
25	G5	Data bus	
26	G6	Data bus	
27	G7	Data bus	
28	R0	Data bus	
29	R1	Data bus	
30	R2	Data bus	
31	R3	Data bus	
32	R4	Data bus	
33	R5	Data bus	
34	R6	Data bus	
35	R7	Data bus	
36	HSYNC	Horizontal Synchronous Signal	
37	VSYNC	Vertical Synchronous Signal	
38	DOTCLK	Data Clock	
39-40	NC	No connect	
41-42	VDD	Power Supply	
43-51	NC	No connect	
52	DEN	Data enabling signal	
53-54	GND	Ground	

9. AC Characteristics

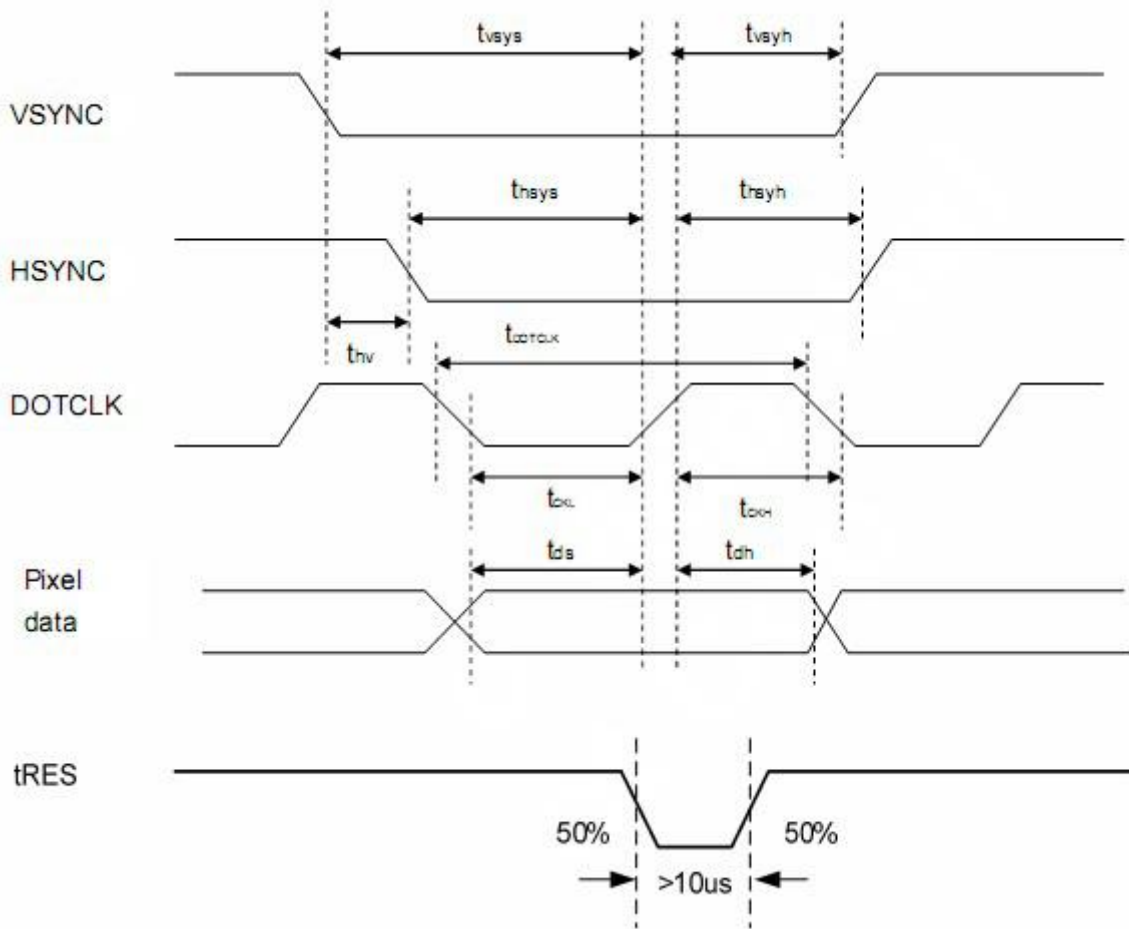
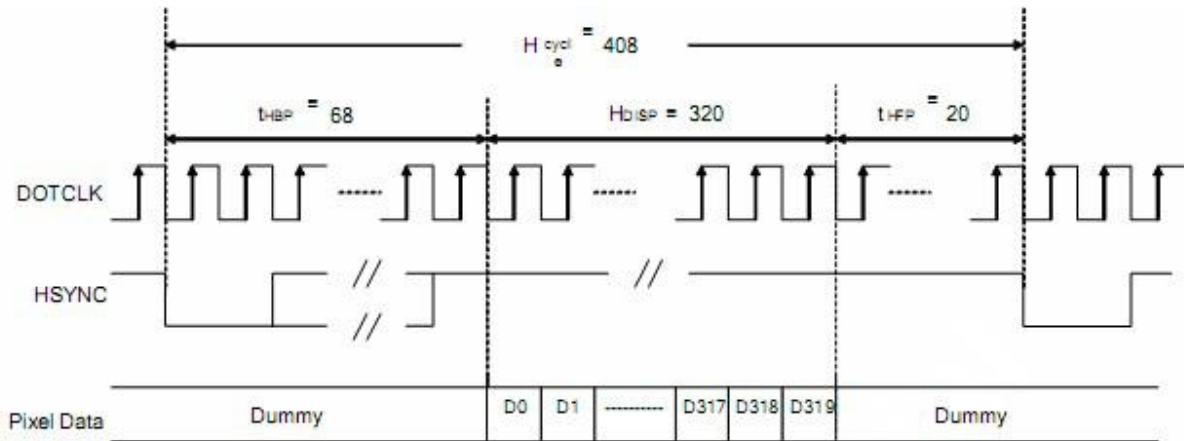

Figure 1: Pixel Timing

Characteristics	Symbol	Min.		Typ.		Max.		Unit
		24 bit	8 bit	24 bit	8 bit	24 bit	8 bit	
DOTCLK Frequency	fDOTCLK	-	-	6.5	19.5	10	30	MHz
DOTCLK Period	tDOTCLK	100	33.3	154	51.3	-	-	ns
Vertical Sync Setup Time	tvsys	20	10	-	-	-	-	ns
Vertical Sync Hold Time	tvsyh	20	10	-	-	-	-	ns
Horizontal Sync Setup Time	thsys	20	10	-	-	-	-	ns
Horizontal Sync Hold Time	thsyh	20	10	-	-	-	-	ns
Phase difference of Sync Signal Falling Edge	thv	1		-		240		tDOTCLK
DOTCLK Low Period	tCKL	50	15	-	-	-	-	ns
DOTCLK High Period	tCKH	50	15	-	-	-	-	ns
Data Setup Time	tds	12	10	-	-	-	-	ns
Data hold Time	tdh	12	10	-	-	-	-	ns
Reset pulse width	tRES	10		-		-		μs

Note: External clock source must be provided to DOTCLK pin of HX8238-D. The driver will not operate if absent of the docking signal.

Table 1: Pixel Timing



(a) Horizontal Data Transaction Timing

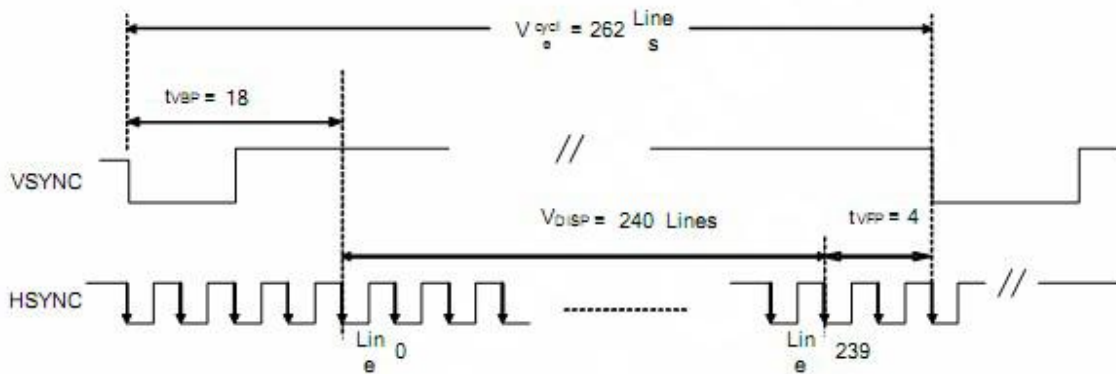

(b) Vertical Data Transaction Timing

Figure 2: Data Transaction Timing in Parallel RGB(24 bit) Interface(SYNC Mode)

Characteristics	Symbol	Min.		Typ.		Max.		Unit
		24 bit	8 bit	24 bit	8 bit	24 bit	8 bit	
DOTCLK Frequency	f _{DOTCLK}	-	-	6.5	19.5	10	30	MHz
DOTCLK Period	t _{DOTCLK}	100	33.3	154	51.3	-	-	ns
Horizontal Frequency (Line)	f _H	-	-	14.9		22.35		KHz
Vertical Frequency (Refresh)	f _V	-	-	60		90		Hz
Horizontal Back Porch	t _{HBP}	-	-	68	204	-	-	t _{DOTCLK}
Horizontal Front Porch	t _{HFP}	-	-	20	60	-	-	t _{DOTCLK}
Horizontal Data Start Point	t _{HBP}	-	-	68	204	-	-	t _{DOTCLK}
Horizontal Blanking Period	t _{HBP} + t _{HFP}	-	-	88	264	-	-	t _{DOTCLK}
Horizontal Display Area	H _{DISP}	-	-	320	960	-	-	t _{DOTCLK}
Horizontal Cycle	H _{cycle}	-	-	408	1224	450	1350	t _{DOTCLK}
Vertical Back Porch	t _{VBP}	-	-	18		-		Lines
Vertical Front Porch	t _{VFP}	-	-	4		-		Lines
Vertical Data Start Point	t _{VBP}	-	-	18		-		Lines
Vertical Blanking Period	t _{VBP} + t _{VFP}	-	-	22		-		Lines
Vertical Display Area	NTSC	V _{DISP}	-	240		-	-	Lines
	PAL			280(PALM=0)				
	PAL			288(PALM=1)				
Vertical Cycle	NTSC	V _{cycle}	-	262		350	-	Lines
	PAL			313				

Table 2: Data Transaction Timing in Normal Operating Mode

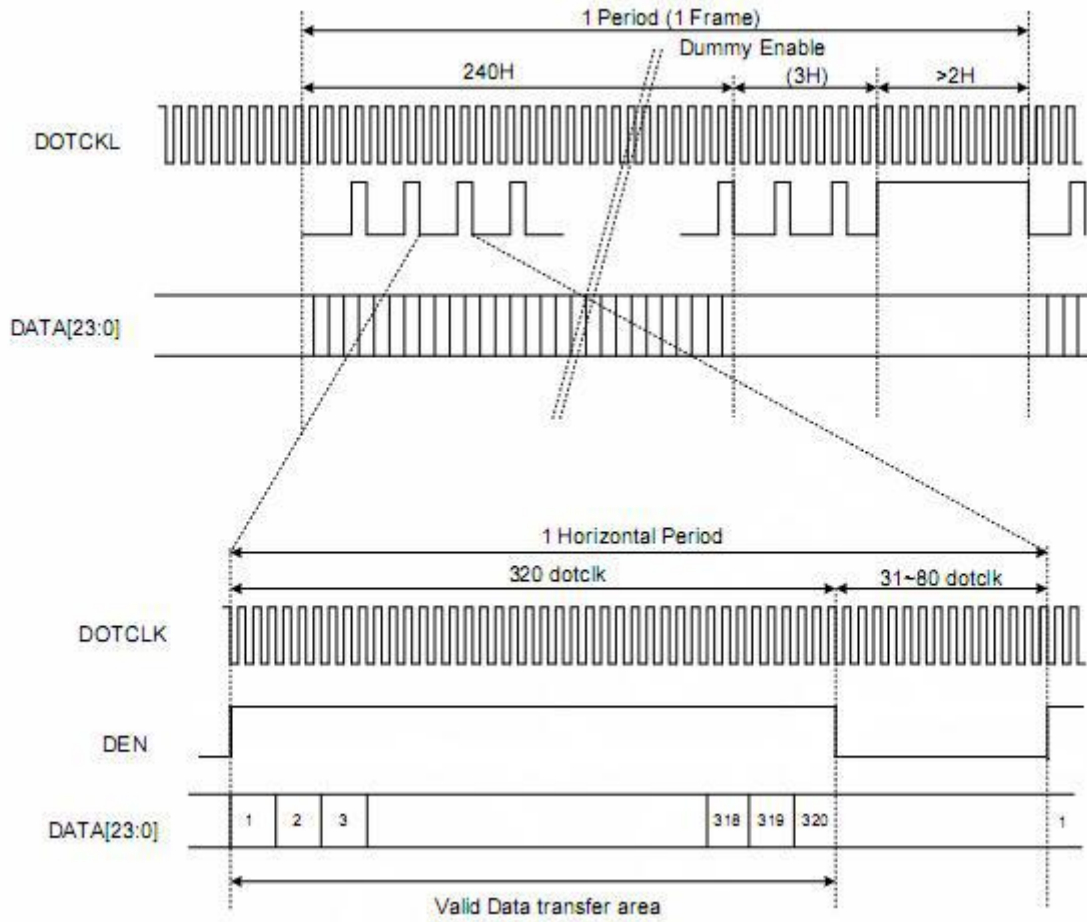

Figure 3: Signal Timing in DE Mode

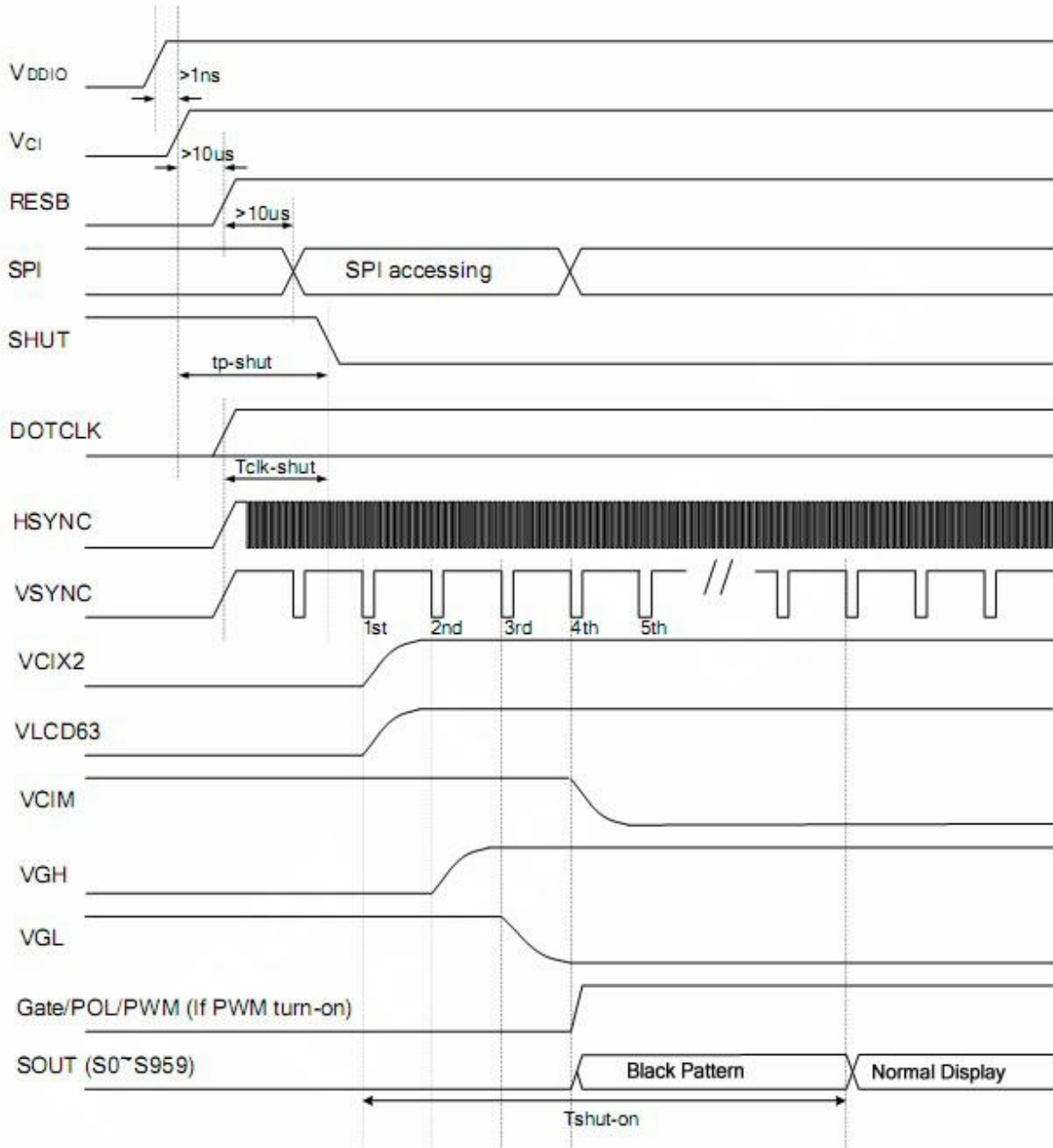

Figure 4: Power Up Sequence

Characteristics	Symbol	Spec.			Unit
		Min.	Typ.	Max.	
VDDD / VDDIO on to falling edge of SHUT	tp-shut	1	-	-	μs
DOTCLK	tclk-shut	1	-	-	clk
Falling edge of SHUT to display start - 1 line: 408 clk - 1 frame: 262 line - DOTCLK = 6.5MHz	tshut-on	-	-	14	frame
		-	166	232.4	ms

Note: It is necessary to input DOTCLK before the falling edge of SHUT.
Display starts at 10th falling edge of VSTNC after the falling edge of SHUT.

Table 3: Power Up Sequence

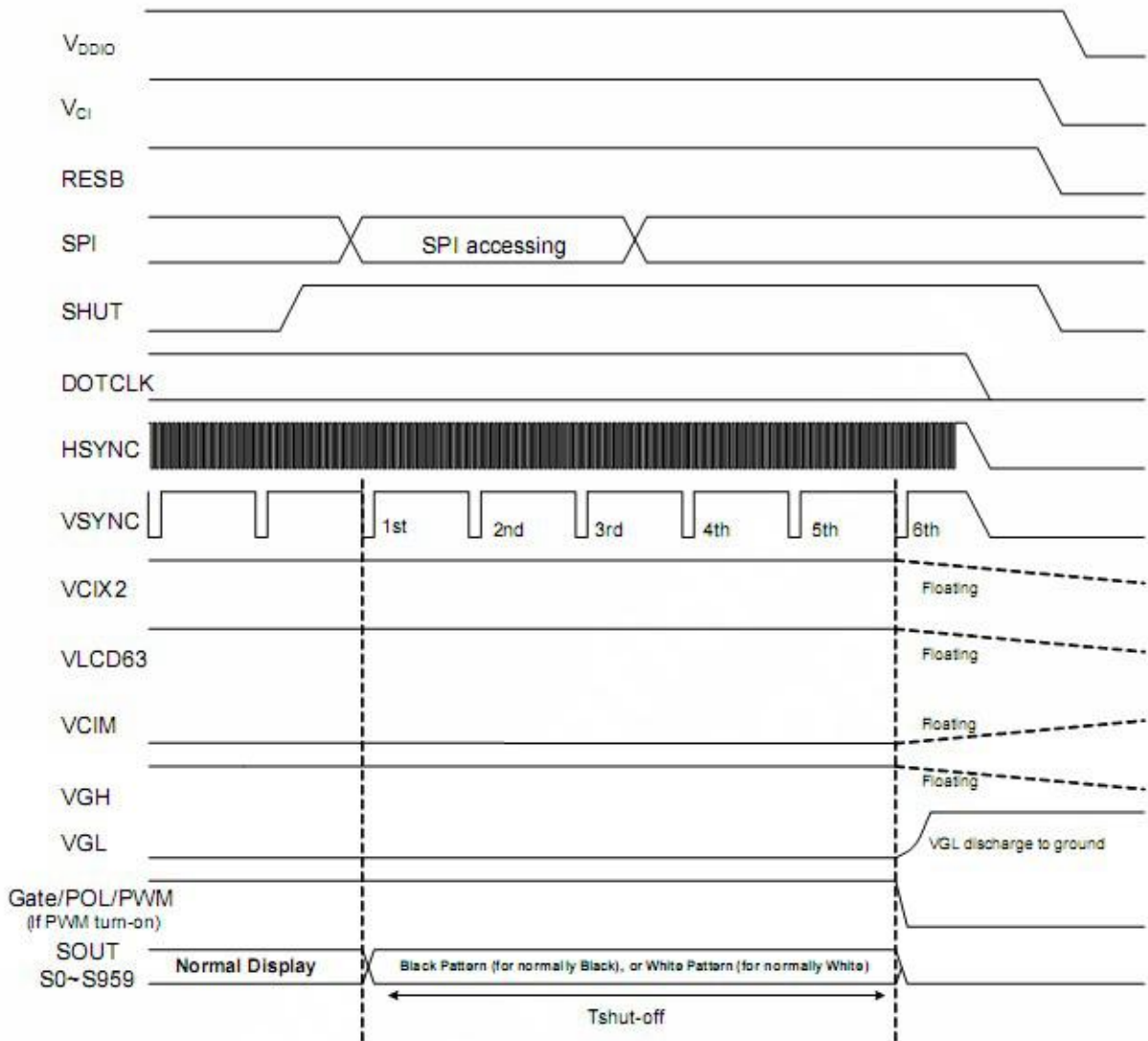

Figure 5: Power Down Sequence

Characteristics	Symbol	Spec.			Unit
		Min.	Typ.	Max.	
Rising edge of SHUT to display off	tshut-off	2	-	-	frame
- 1 line: 408 clk - 1 frame: 262 line - DOTCLK = 6.5MHz		33.4	-	-	ms

Note: DOTCLK must be maintained at least 2 frames after the rising edge of SHUT.
 Display become off at the 2nd falling edge of VSTNC after the falling edge of SHUT.
 If RESET signal is necessary for power down, provide it after the 2-frames-cycle of the SHUT period.

Table 4: Power Down Sequence

• Write SPI

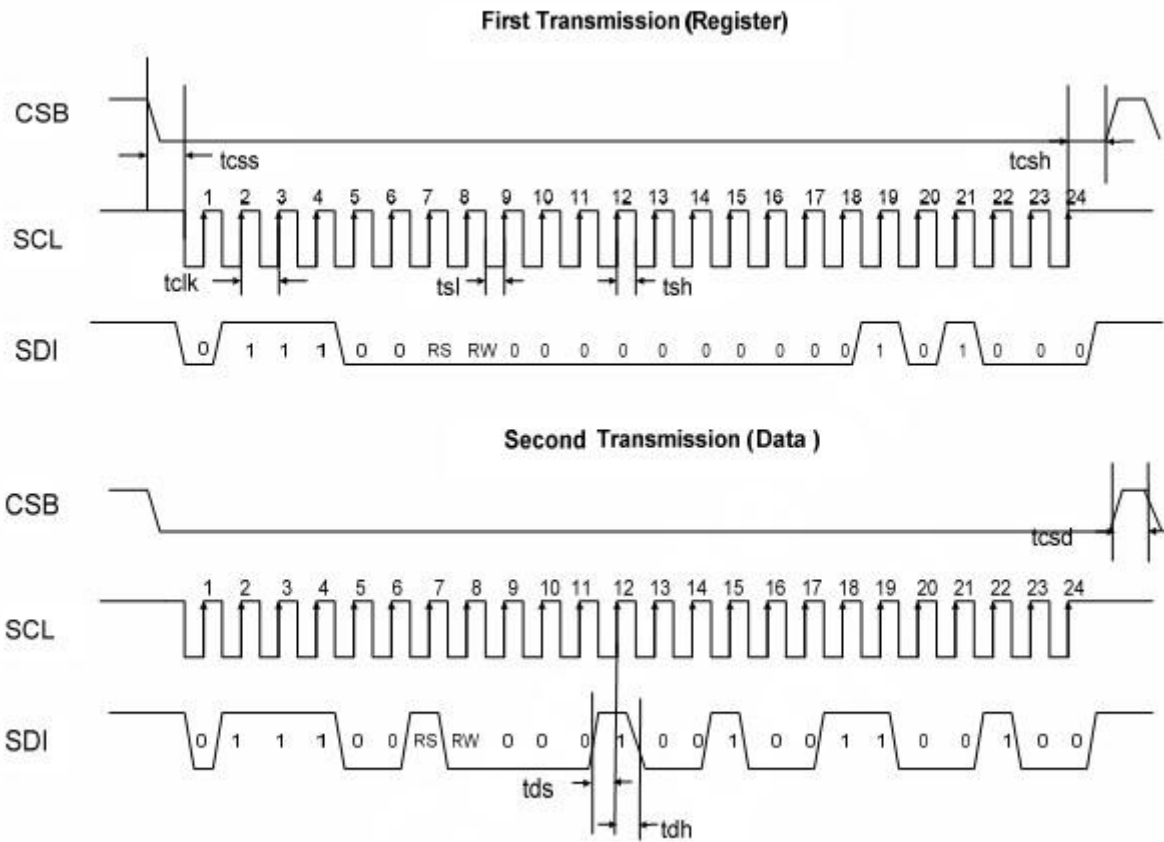

Note: The example writes "0x1264h" to register R28h.
SPID connected to VSS.

Figure 6: (a)SPI interface Timing Diagram & Write SPI Example

• Read SPI

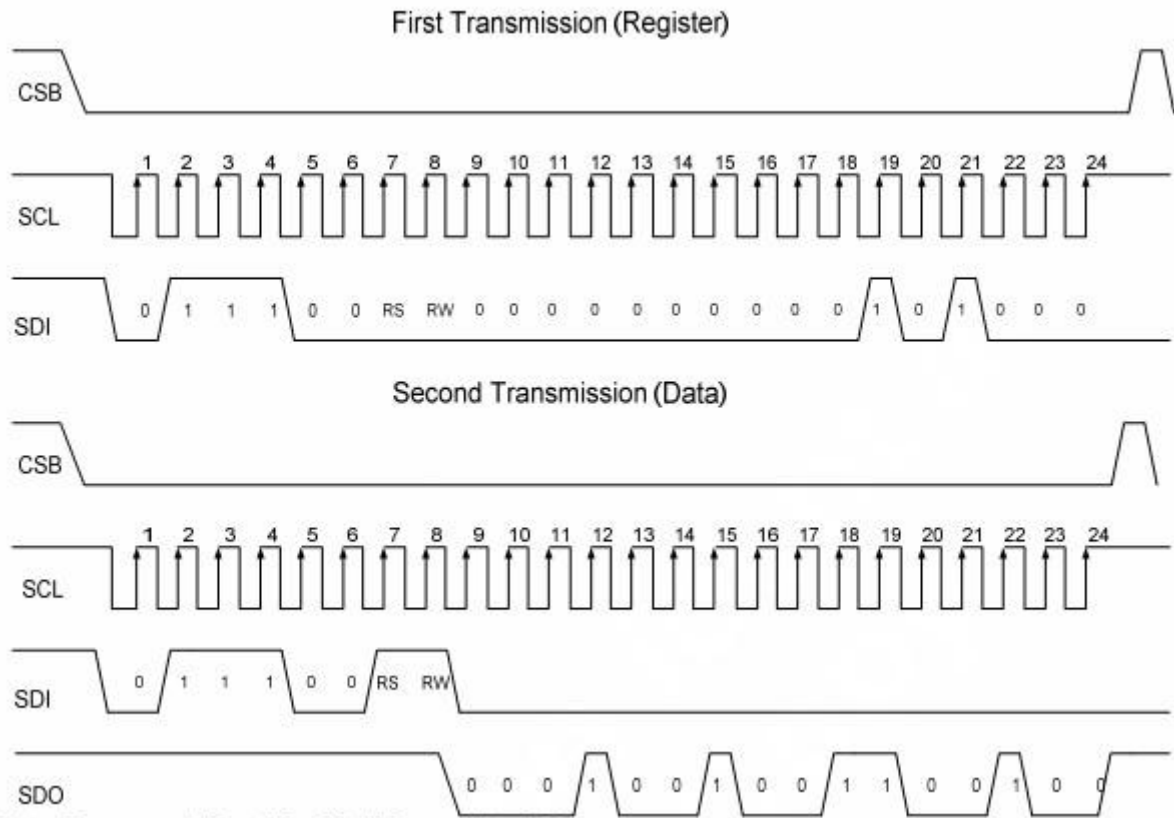

Note: The example Read "0x1264h" from register R28h.

Figure 7: (b)SPI interface Timing Diagram & Read SPI Example

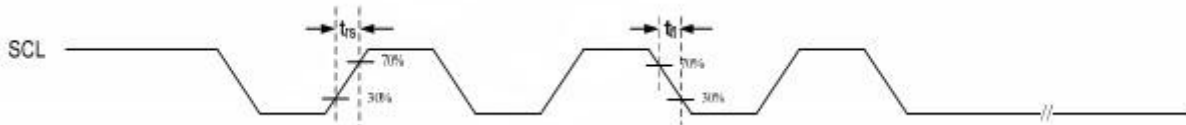

Figure 8: Rising/Falling Time

Characteristics	Symbol	Spec.			Unit
		Min.	Typ.	Max.	
Serial Clock Frequency	fclk	-	-	20	MHz
Serial Clock Cycle Time	tclk	50	-	-	ns
Clock Low Width	tsl	25	-	-	ns
Clock High Width	tsh	25	-	-	ns
Clock Rising Time	trs	-	-	30	ns
Clock Falling Time	tfl	-	-	30	ns
Chip Select Hold Time	tcsh	10	-	-	ns
Chip Select High Delay Time	tcsd	20	-	-	ns
Data Setup Time	tds	5	-	-	ns
Data Hold Time	tdh	10	-	-	ns

Table 5: SPI Timing

10. Quality Assurance

10.1.Purpose

This standard for Quality Assurance assures the quality of LCD module products supplied to customer.

10.2.Standard for Quality Test

10.2.1. Sampling Plan:

GB2828.1-2012

Single sampling, general inspection level II

10.2.2. Sampling Criteria:

Visual inspection: AQL 1.5%

Electrical functional: AQL 0.65%.

10.2.3. Reliability Test:

Detailed requirement refer to Reliability Test Specification.

10.3.Nonconforming Analysis & Disposition

10.3.1. Nonconforming analysis:

10.3.1.1. Customer should provide overall information of non-conforming sample for their complaints.

10.3.1.2. After receipt of detailed information from customer, the analysis of nonconforming parts usually should be finished in one week.

10.3.1.3. If cannot finish the analysis on time, customer will be notified with the progress status.

10.3.2. Disposition of nonconforming:

10.3.2.1. Non-conforming product over PPM level will be replaced.

10.3.2.2. The cause of non-conformance will be analyzed. Corrective action will be discussed and implemented.

10.4.Agreement Items

Shall negotiate with customer if the following situation occurs:

10.4.1. There is any discrepancy in standard of quality assurance.

10.4.2. Additional requirement to be added in product specification.

10.4.3. Any other special problem.

10.5.Standard of the Product Visual Inspection

10.5.1. Appearance inspection:

10.5.1.1. The inspection must be under illumination about 1000 – 1500 lx, and the distance of view must be at 30cm ± 2cm.

10.5.1.2. The viewing angle should be 45° from the vertical line without reflection light or follows customer's viewing angle specifications.

10.5.1.3. Definition of area: A Zone: Active Area, B Zone: Viewing Area,

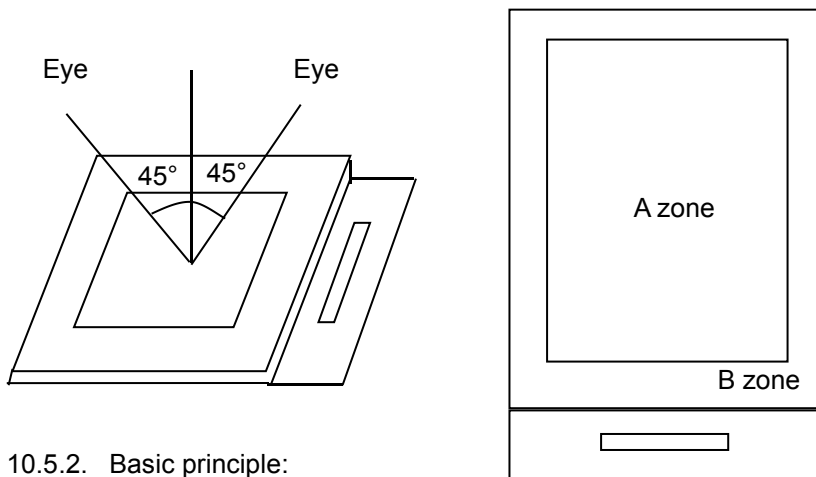

10.5.2. Basic principle:

10.5.2.1. A set of sample to indicate the limit of acceptable quality level must be discussed by both us and customer when there is any dispute happened.

10.5.2.2. New item must be added on time when it is necessary.

10.6. Inspection Specification

No.	Item	Criteria (Unit: mm)																			
01	Black / White spot Foreign material (Round type) Pinholes Stain Particles inside cell. (Minor defect)	$\phi = (a + b) / 2$	<table border="1"> <thead> <tr> <th>Size \ Area</th> <th>Acc. Qty</th> </tr> </thead> <tbody> <tr> <td>$\phi \leq 0.10$</td> <td>Ignore</td> </tr> <tr> <td>$0.10 < \phi \leq 0.15$</td> <td>2</td> </tr> <tr> <td>$0.15 < \phi \leq 0.25$</td> <td>1</td> </tr> <tr> <td>$0.25 < \phi$</td> <td>0</td> </tr> <tr> <td>Total</td> <td>2 no include $\phi \leq 0.10$</td> </tr> </tbody> </table>	Size \ Area	Acc. Qty	$\phi \leq 0.10$	Ignore	$0.10 < \phi \leq 0.15$	2	$0.15 < \phi \leq 0.25$	1	$0.25 < \phi$	0	Total	2 no include $\phi \leq 0.10$						
			Size \ Area	Acc. Qty																	
$\phi \leq 0.10$	Ignore																				
$0.10 < \phi \leq 0.15$	2																				
$0.15 < \phi \leq 0.25$	1																				
$0.25 < \phi$	0																				
Total	2 no include $\phi \leq 0.10$																				
Distance between 2 defects should more than 3mm apart.																					
02	Electrical Defect (Minor defect)	<table border="1"> <thead> <tr> <th></th> <th>Display Area</th> <th>Total</th> <th rowspan="3">Note 1</th> </tr> </thead> <tbody> <tr> <td>Bright dot</td> <td>0</td> <td>0</td> </tr> <tr> <td>Dark dot</td> <td>$N \leq 2$</td> <td>$N \leq 2$</td> </tr> <tr> <td>Total dot</td> <td>$N \leq 2$</td> <td>$N \leq 2$</td> <td></td> </tr> <tr> <td>Mura</td> <td colspan="2">Not visible through 5% ND filters.</td> <td>Note 2</td> </tr> </tbody> </table>			Display Area	Total	Note 1	Bright dot	0	0	Dark dot	$N \leq 2$	$N \leq 2$	Total dot	$N \leq 2$	$N \leq 2$		Mura	Not visible through 5% ND filters.		Note 2
			Display Area	Total	Note 1																
		Bright dot	0	0																	
		Dark dot	$N \leq 2$	$N \leq 2$																	
Total dot	$N \leq 2$	$N \leq 2$																			
Mura	Not visible through 5% ND filters.		Note 2																		
Remark:																					
1. Bright dot caused by scratch and foreign object accords to item 1.																					

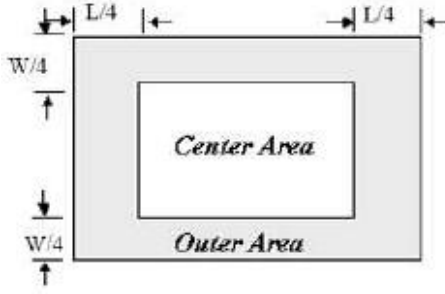
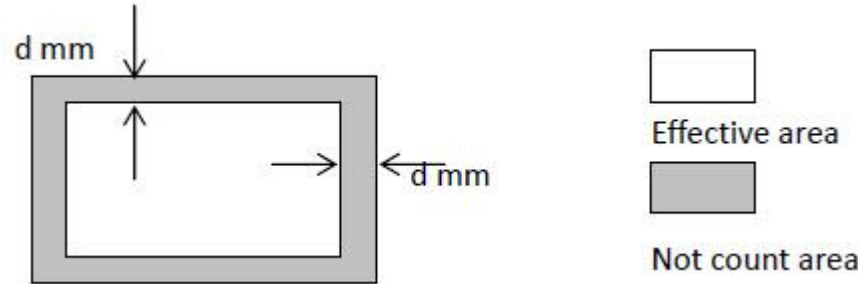
03	Inactive Area (Minor defect)	<p>Line Criteria: $L \leq 1\text{mm}$, $W \leq 0.1\text{mm}$, Dot Criteria: Please refer to Note 1,2&3</p> <p>Note1: Definition of Area</p>  <p>Note2:</p> <table border="1" data-bbox="497 721 1423 1093"> <thead> <tr> <th>尺寸</th> <th>缺陷</th> <th>中心 Center</th> <th>外围 Outer</th> <th>總數 Total</th> <th>備註</th> </tr> </thead> <tbody> <tr> <td>All</td> <td>$\varnothing < 0.2\text{mm}$;</td> <td colspan="4" style="text-align: center;">不計數</td> </tr> <tr> <td><6"</td> <td>$0.2 \leq \varnothing \leq 0.3\text{mm}$; $L \leq 1\text{mm}, W \leq 0.1\text{mm}$</td> <td>$N \leq 1$</td> <td>$N \leq 2$</td> <td>$N \leq 3$</td> <td></td> </tr> <tr> <td>6~8"</td> <td>$0.2 \leq \varnothing \leq 0.5\text{mm}$; $L \leq 1\text{mm}, W \leq 0.1\text{mm}$</td> <td>$N \leq 2$</td> <td>$N \leq 3$</td> <td>$N \leq 5$</td> <td>$0.4 \leq \varnothing \leq 0.5\text{mm}, N \leq 1$ is allowed at outer.)</td> </tr> <tr> <td>8.1"~10.1"</td> <td>$0.2 \leq \varnothing \leq 0.5\text{mm}$; $L \leq 1\text{mm}, W \leq 0.1\text{mm}$</td> <td>$N \leq 2$</td> <td>$N \leq 5$</td> <td>$N \leq 7$</td> <td>$0.4 \leq \varnothing \leq 0.5\text{mm}, N \leq 2$ is allowed at outer.)</td> </tr> <tr> <td>10.2"~15"</td> <td>$0.2 \leq \varnothing \leq 0.5\text{mm}$; $L \leq 1\text{mm}, W \leq 0.1\text{mm}$</td> <td>$N \leq 5$</td> <td>$N \leq 10$</td> <td>$N \leq 15$</td> <td>$(0.4 \leq \varnothing \leq 0.5\text{mm}, N \leq 5$ is allowed at outer.)</td> </tr> </tbody> </table> <p>Note3: Inactive area $D < 0.2\text{mm}$ is not counted without appearance observation.</p> <p>Remark: Effective area is from the POL cutting side to 0.5mm of inside. This is no count area. Other part is effective area. In no count area, any defect can ignore. In effective area, have to judge from above-mentioned specification.</p> 	尺寸	缺陷	中心 Center	外围 Outer	總數 Total	備註	All	$\varnothing < 0.2\text{mm}$;	不計數				<6"	$0.2 \leq \varnothing \leq 0.3\text{mm}$; $L \leq 1\text{mm}, W \leq 0.1\text{mm}$	$N \leq 1$	$N \leq 2$	$N \leq 3$		6~8"	$0.2 \leq \varnothing \leq 0.5\text{mm}$; $L \leq 1\text{mm}, W \leq 0.1\text{mm}$	$N \leq 2$	$N \leq 3$	$N \leq 5$	$0.4 \leq \varnothing \leq 0.5\text{mm}, N \leq 1$ is allowed at outer.)	8.1"~10.1"	$0.2 \leq \varnothing \leq 0.5\text{mm}$; $L \leq 1\text{mm}, W \leq 0.1\text{mm}$	$N \leq 2$	$N \leq 5$	$N \leq 7$	$0.4 \leq \varnothing \leq 0.5\text{mm}, N \leq 2$ is allowed at outer.)	10.2"~15"	$0.2 \leq \varnothing \leq 0.5\text{mm}$; $L \leq 1\text{mm}, W \leq 0.1\text{mm}$	$N \leq 5$	$N \leq 10$	$N \leq 15$	$(0.4 \leq \varnothing \leq 0.5\text{mm}, N \leq 5$ is allowed at outer.)
		尺寸	缺陷	中心 Center	外围 Outer	總數 Total	備註																															
All	$\varnothing < 0.2\text{mm}$;	不計數																																				
<6"	$0.2 \leq \varnothing \leq 0.3\text{mm}$; $L \leq 1\text{mm}, W \leq 0.1\text{mm}$	$N \leq 1$	$N \leq 2$	$N \leq 3$																																		
6~8"	$0.2 \leq \varnothing \leq 0.5\text{mm}$; $L \leq 1\text{mm}, W \leq 0.1\text{mm}$	$N \leq 2$	$N \leq 3$	$N \leq 5$	$0.4 \leq \varnothing \leq 0.5\text{mm}, N \leq 1$ is allowed at outer.)																																	
8.1"~10.1"	$0.2 \leq \varnothing \leq 0.5\text{mm}$; $L \leq 1\text{mm}, W \leq 0.1\text{mm}$	$N \leq 2$	$N \leq 5$	$N \leq 7$	$0.4 \leq \varnothing \leq 0.5\text{mm}, N \leq 2$ is allowed at outer.)																																	
10.2"~15"	$0.2 \leq \varnothing \leq 0.5\text{mm}$; $L \leq 1\text{mm}, W \leq 0.1\text{mm}$	$N \leq 5$	$N \leq 10$	$N \leq 15$	$(0.4 \leq \varnothing \leq 0.5\text{mm}, N \leq 5$ is allowed at outer.)																																	

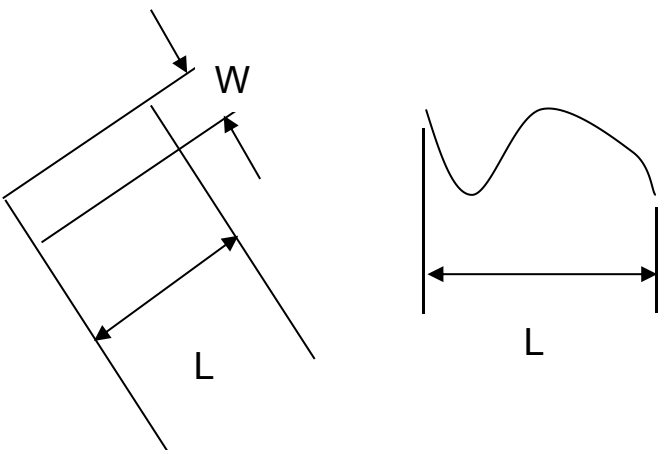
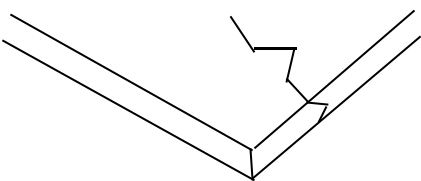
<p>04</p>	<p>Black and White line Scratch Foreign material (Line type) (Minor defect)</p>	 <table border="1" data-bbox="555 824 1181 1176"> <thead> <tr> <th>Length</th> <th>Width</th> <th>Acc. Qty</th> </tr> </thead> <tbody> <tr> <td>/</td> <td>$W \leq 0.03$</td> <td>Ignore</td> </tr> <tr> <td>$L \leq 2.5$</td> <td>$0.03 < W \leq 0.05$</td> <td>3</td> </tr> <tr> <td>$L \leq 2.5$</td> <td>$0.05 < W \leq 0.10$</td> <td>2</td> </tr> <tr> <td>/</td> <td>$0.1 < W$</td> <td>0</td> </tr> <tr> <td colspan="2" style="text-align: center;">Total</td> <td>3</td> </tr> </tbody> </table> <p>Distance between 2 defects should more than 3mm apart. Scratches not viewable through the back of the display are acceptable.</p>	Length	Width	Acc. Qty	/	$W \leq 0.03$	Ignore	$L \leq 2.5$	$0.03 < W \leq 0.05$	3	$L \leq 2.5$	$0.05 < W \leq 0.10$	2	/	$0.1 < W$	0	Total		3
Length	Width	Acc. Qty																		
/	$W \leq 0.03$	Ignore																		
$L \leq 2.5$	$0.03 < W \leq 0.05$	3																		
$L \leq 2.5$	$0.05 < W \leq 0.10$	2																		
/	$0.1 < W$	0																		
Total		3																		
<p>05</p>	<p>Glass Crack (Minor defect)</p>	 <p>Crack is potential to enlarge, any type is not allowed.</p>																		

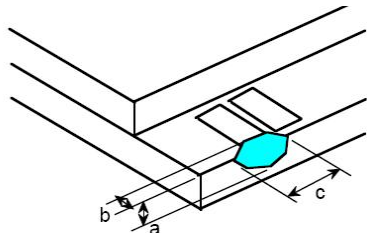
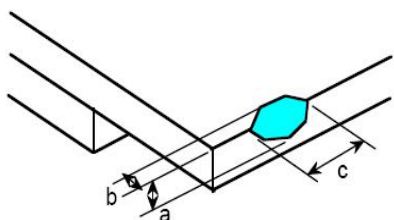
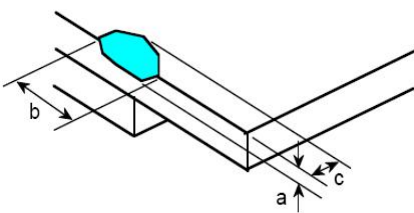
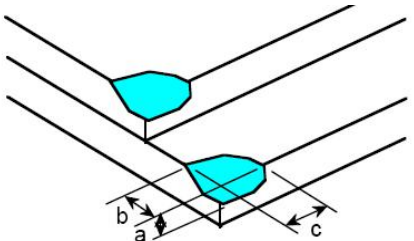
<p>06</p>	<p>Glass Chipping Pad Area: (Minor defect)</p> 	<table border="1"> <thead> <tr> <th>Length and Width</th> <th>Acc. Qty</th> </tr> </thead> <tbody> <tr> <td>$c > 3.0, b < 1.0$</td> <td>1</td> </tr> <tr> <td>$c < 3.0, b < 1.0$</td> <td>3</td> </tr> <tr> <td colspan="2" style="text-align: center;">$a < \text{Glass Thickness}$</td> </tr> </tbody> </table>	Length and Width	Acc. Qty	$c > 3.0, b < 1.0$	1	$c < 3.0, b < 1.0$	3	$a < \text{Glass Thickness}$			
Length and Width	Acc. Qty											
$c > 3.0, b < 1.0$	1											
$c < 3.0, b < 1.0$	3											
$a < \text{Glass Thickness}$												
<p>07</p>	<p>Glass Chipping Rear of Pad Area: (Minor defect)</p> 	<table border="1"> <thead> <tr> <th>Length and Width</th> <th>Acc. Qty</th> </tr> </thead> <tbody> <tr> <td>$c > 3.0, b < 1.0$</td> <td>1</td> </tr> <tr> <td>$c < 3.0, b < 1.0$</td> <td>2</td> </tr> <tr> <td>$c < 3.0, b < 0.5$</td> <td>4</td> </tr> <tr> <td colspan="2" style="text-align: center;">$a < \text{Glass Thickness}$</td> </tr> </tbody> </table>	Length and Width	Acc. Qty	$c > 3.0, b < 1.0$	1	$c < 3.0, b < 1.0$	2	$c < 3.0, b < 0.5$	4	$a < \text{Glass Thickness}$	
Length and Width	Acc. Qty											
$c > 3.0, b < 1.0$	1											
$c < 3.0, b < 1.0$	2											
$c < 3.0, b < 0.5$	4											
$a < \text{Glass Thickness}$												
<p>08</p>	<p>Glass Chipping Except Pad Area: (Minor defect)</p> 	<table border="1"> <thead> <tr> <th>Length and Width</th> <th>Acc. Qty</th> </tr> </thead> <tbody> <tr> <td>$c > 3.0, b < 1.0$</td> <td>1</td> </tr> <tr> <td>$c < 3.0, b < 1.0$</td> <td>2</td> </tr> <tr> <td>$c < 3.0, b < 0.5$</td> <td>4</td> </tr> <tr> <td colspan="2" style="text-align: center;">$a < \text{Glass Thickness}$</td> </tr> </tbody> </table>	Length and Width	Acc. Qty	$c > 3.0, b < 1.0$	1	$c < 3.0, b < 1.0$	2	$c < 3.0, b < 0.5$	4	$a < \text{Glass Thickness}$	
Length and Width	Acc. Qty											
$c > 3.0, b < 1.0$	1											
$c < 3.0, b < 1.0$	2											
$c < 3.0, b < 0.5$	4											
$a < \text{Glass Thickness}$												
<p>09</p>	<p>Glass Corner Chipping: (Minor defect)</p> 	<table border="1"> <thead> <tr> <th>Length and Width</th> <th>Acc. Qty</th> </tr> </thead> <tbody> <tr> <td>$c < 3.0, b < 3.0$</td> <td>Ignore</td> </tr> <tr> <td colspan="2" style="text-align: center;">$a < \text{Glass Thickness}$</td> </tr> </tbody> </table>	Length and Width	Acc. Qty	$c < 3.0, b < 3.0$	Ignore	$a < \text{Glass Thickness}$					
Length and Width	Acc. Qty											
$c < 3.0, b < 3.0$	Ignore											
$a < \text{Glass Thickness}$												

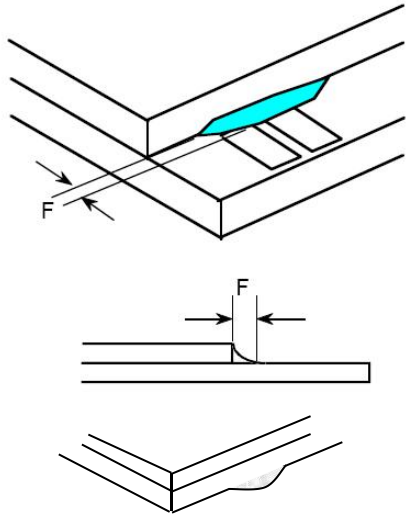
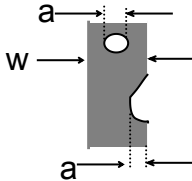
10	<p>Glass Burr: (Minor defect)</p> 	<table border="1" data-bbox="868 282 1339 369"> <thead> <tr> <th>Length</th> <th>Acc. Qty</th> </tr> </thead> <tbody> <tr> <td>$F < 1.0$</td> <td>Ignore</td> </tr> </tbody> </table> <p>Glass burr don't affect assemble and module dimension.</p>	Length	Acc. Qty	$F < 1.0$	Ignore						
Length	Acc. Qty											
$F < 1.0$	Ignore											
11	<p>FPC Defect: (Minor defect)</p> 	<p>11.1 Dent, pinhole width $a < w/3$. (w: circuitry width.)</p> <p>11.2 Open circuit is unacceptable.</p> <p>11.3 No oxidation, contamination and distortion.</p>										
12	<p>Bubble on Polarizer (Minor defect)</p>	<table border="1" data-bbox="743 1234 1214 1447"> <thead> <tr> <th>Diameter</th> <th>Acc. Qty</th> </tr> </thead> <tbody> <tr> <td>$\varphi \leq 0.20$</td> <td>Ignore</td> </tr> <tr> <td>$0.20 < \varphi \leq 0.30$</td> <td>4</td> </tr> <tr> <td>$0.30 < \varphi \leq 0.50$</td> <td>1</td> </tr> <tr> <td>$0.50 < \varphi$</td> <td>None</td> </tr> </tbody> </table>	Diameter	Acc. Qty	$\varphi \leq 0.20$	Ignore	$0.20 < \varphi \leq 0.30$	4	$0.30 < \varphi \leq 0.50$	1	$0.50 < \varphi$	None
Diameter	Acc. Qty											
$\varphi \leq 0.20$	Ignore											
$0.20 < \varphi \leq 0.30$	4											
$0.30 < \varphi \leq 0.50$	1											
$0.50 < \varphi$	None											
13	<p>Dent on Polarizer (Minor defect)</p>	<table border="1" data-bbox="743 1509 1214 1722"> <thead> <tr> <th>Diameter</th> <th>Acc. Qty</th> </tr> </thead> <tbody> <tr> <td>$\varphi \leq 0.20$</td> <td>Ignore</td> </tr> <tr> <td>$0.20 < \varphi \leq 0.30$</td> <td>4</td> </tr> <tr> <td>$0.30 < \varphi \leq 0.50$</td> <td>1</td> </tr> <tr> <td>$0.50 < \varphi$</td> <td>None</td> </tr> </tbody> </table>	Diameter	Acc. Qty	$\varphi \leq 0.20$	Ignore	$0.20 < \varphi \leq 0.30$	4	$0.30 < \varphi \leq 0.50$	1	$0.50 < \varphi$	None
Diameter	Acc. Qty											
$\varphi \leq 0.20$	Ignore											
$0.20 < \varphi \leq 0.30$	4											
$0.30 < \varphi \leq 0.50$	1											
$0.50 < \varphi$	None											
14	<p>Bezel</p>	<p>14.1 No rust, distortion on the Bezel.</p> <p>14.2 No visible fingerprints, stains or other contamination.</p>										

15	Touch Panel	<p>D: Diameter W: width L: length 15.1 Spot: $D < 0.25$ is acceptable $0.25 \leq D \leq 0.4$ 2dots are acceptable and the distance between defects should more than 10 mm. $D > 0.4$ is unacceptable 15.2 Dent: $D > 0.40$ is unacceptable 15.3 Scratch: $W \leq 0.03$, $L \leq 10$ is acceptable, $0.03 < W \leq 0.10$, $L \leq 10$ is acceptable Distance between 2 defects should more than 10 mm. $W > 0.10$ is unacceptable.</p>
16	PCB	<p>16.1 No distortion or contamination on PCB terminals. 16.2 All components on PCB must same as documented on the BOM/component layout. 16.3 Follow IPC-A-600F.</p>
17	Soldering	Follow IPC-A-610C standard
18	Electrical Defect (Major defect)	<p>The below defects must be rejected. 18.1 Missing vertical / horizontal segment, 18.2 Abnormal Display. 18.3 No function or no display. 18.4 Current exceeds product specifications. 18.5 LCD viewing angle defect. 18.6 No Backlight. 18.7 Dark Backlight. 18.8 Touch Panel no function.</p>

Remark: LCD Panel Broken shall be rejected. Defect out of LCD viewing area is acceptable.

10.7. Classification of Defects

- 10.7.1. Visual defects (Except no / wrong label) are treated as minor defect and electrical defect is major.
- 10.7.2. Two minor defects are equal to one major in lot sampling inspection.

10.8. Identification/marketing criteria

Any unit with illegible / wrong /double or no marking/ label shall be rejected.

10.9. Packing

- 10.9.1. There should be no damage of the outside carton box, each packaging box should have one identical label.
- 10.9.2. Modules inside package box should have compliant mark.
- 10.9.3. All direct package materials shall offer ESD protection.

Note1: Bright dot is defined as the defective area of the dot is larger than 50% of one sub-pixel area.

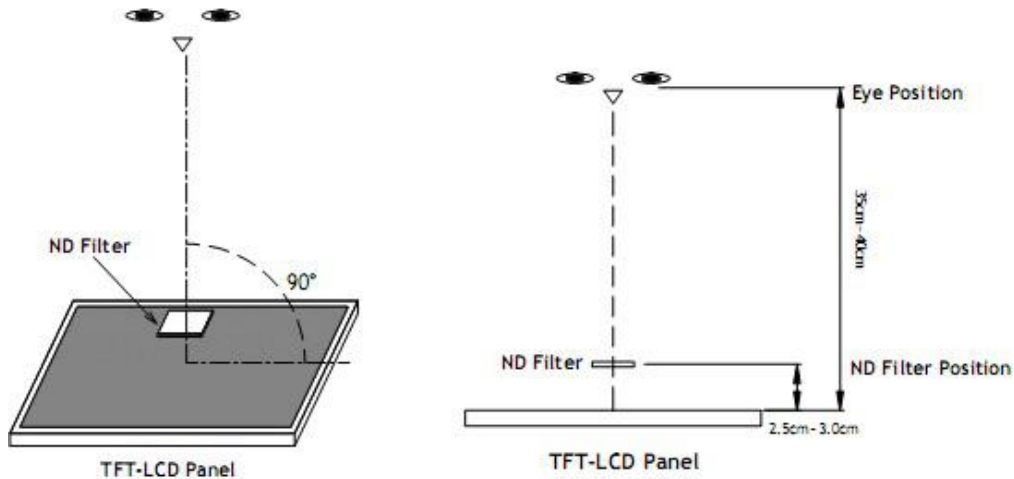

Bright dot: The bright dot size defect at black display pattern. It can be recognized by 2% transparency of filter when the distance between eyes and panel is $350\text{mm} \pm 50\text{mm}$.

Dark dot: Cyan, Magenta or Yellow dot size defect at white display pattern. It can be recognized by 5% transparency of filter when the distance between eyes and panel is $350\text{mm} \pm 50\text{mm}$.

Note2: Mura on display which appears darker / brighter against background brightness on parts of display area.

11. Reliability Specification

No	Item	Condition	Quantity	Criteria
1	High Temperature Operating	70°C, 96Hrs	2	GB/T2423.2-2008
2	Low Temperature Operating	-20°C, 96Hrs	2	GB/T2423.1-2008
3	High Humidity	50°C, 90%RH, 96Hrs	2	GB/T2423.3-2006
4	High Temperature Storage	80°C, 96Hrs	2	GB/T2423.2-2008
5	Low Temperature Storage	-30°C, 96Hrs	2	GB/T2423.1-2008
6	Thermal Cycling Test	-20°C, 60min~70°C, 60min, 20 cycles.	2	GB/T2423.22-2012
7	Packing vibration	Frequency range:10Hz~50Hz Acceleration of gravity:5G X, Y, Z 30 min for each direction.	2	GB/T5170.14-2009
8	Electrical Static Discharge	Air:±8KV 150pF/330Ω 5 times	2	GB/T17626.2-2006
		Contact:±4KV 150pF/330Ω 5 times		
9	Drop Test (Packaged)	Height:80 cm,1 corner, 3 edges, 6 surfaces.	2	GB/T2423.8-1995

Note1. No deflection cosmetic and operational function allowable.

Note2. Total current Consumption should be below double of initial value

12. Precautions and Warranty

12.1. Safety

- 12.1.1. The liquid crystal in the LCD is poisonous. Do not put it in your mouth. If the liquid crystal touches your skin or clothes, wash it off immediately using soap and water.
- 12.1.2. Since the liquid crystal cells are made of glass, do not apply strong impact on them. Handle with care.

12.2. Handling

- 12.2.1. Reverse and use within ratings in order to keep performance and prevent damage.
- 12.2.2. Do not wipe the polarizer with dry cloth, as it might cause scratch. If the surface of the LCD needs to be cleaned, wipe it swiftly with cotton or other soft cloth soaked with petroleum IPA, do not use other chemicals.

12.3. Storage

- 12.3.1. Do not store the LCD module beyond the specified temperature ranges.
- 12.3.2. Strong light exposure causes degradation of polarizer and color filter.

12.4. Metal Pin (Apply to Products with Metal Pins)

12.4.1. Pins of LCD and Backlight

12.4.1.1. Solder tip can touch and press on the tip of Pin LEAD during the soldering

12.4.1.2. Recommended Soldering Conditions

Solder Type: Sn96.3~94-Ag3.3~4.3-Cu0.4~1.1

Maximum Solder Temperature: 370°C

Maximum Solder Time: 3s at the maximum temperature

Recommended Soldering Temp: 350±20°C

Typical Soldering Time: ≤3s

12.4.1.3. Solder Wetting

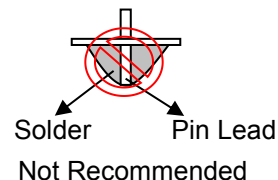
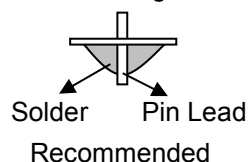

12.4.2. Pins of EL

12.4.2.1. Solder tip can touch and press on the tip of EL leads during soldering.

12.4.2.2. No Solder Paste on the soldering pad on the motherboard is recommended.

12.4.2.3. Recommended Soldering Conditions

Solder type: Nippon Alimit Leadfree SR-34, size 0.5mm

Recommended Solder Temperature: 270~290°C

Typical Soldering Time: ≤2s

Minimum solder distance from EL lamp (body): 2.0mm

12.4.2.4. No horizontal press on the EL leads during soldering.

12.4.2.5. 180° bend EL leads three times is not allowed.

12.4.2.6. Solder Wetting



Recommended

Not Recommended

12.4.2.7. The type of the solder iron:

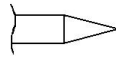

Recommended

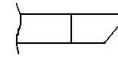

Not Recommended

12.4.2.8. Solder Pad

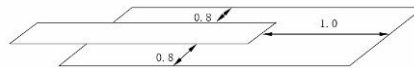

12.5. Operation

- 12.5.1. Do not drive LCD with DC voltage
- 12.5.2. Response time will increase below lower temperature
- 12.5.3. Display may change color with different temperature
- 12.5.4. Mechanical disturbance during operation, such as pressing on the display area, may cause the segments to appear “fractured”.
- 12.5.5. Do not connect or disconnect the LCM to or from the system when power is on.
- 12.5.6. Never use the LCM under abnormal condition of high temperature and high humidity.
- 12.5.7. Module has high frequency circuits. Sufficient suppression to the electromagnetic interface shall be done by system manufacturers. Grounding and shielding methods may be important to minimize the interference.
- 12.5.8. Do not display the fixed pattern for long time (we suggest the time not longer than one hour) because it may develop image sticking due to the TFT structure.

12.6. Static Electricity

- 12.6.1. CMOS LSIs are equipped in this unit, so care must be taken to avoid the electro-static charge, by ground human body, etc.
- 12.6.2. The normal static prevention measures should be observed for work clothes and benches.
- 12.6.3. The module should be kept into anti-static bags or other containers resistant to static for storage.

12.7. Limited Warranty

- 12.7.1. Our warranty liability is limited to repair and/or replacement. We will not be responsible for any consequential loss.
- 12.7.2. If possible, we suggest customer to use up all modules in six months. If the module storage time over twelve months, we suggest that recheck it before the module be used.
- 12.7.3. After the product shipped, any product quality issues must be feedback within three months, otherwise, we will not be responsible for the subsequent or consequential events.

13. Packaging

TBD

