

SPECIFICATIONS

CUSTOMER : _____

SAMPLE CODE : SH720128T003-ZBC02

MASS PRODUCTION CODE : PH720128T003-ZBC02

SAMPLE VERSION : 01

SPECIFICATIONS EDITION : 006

DRAWING NO. (Ver.) : LMD-PH720128T003-ZBC02 (Ver.002)

PACKAGING NO. (Ver.) : PKG-PH720128T003-ZBC02(Ver.001)

Customer Approved

Date:

Approved	Checked	Designer
黃秋源 Oliver Huang	石建莊 Stone Shin	劉俊毅 Terry Liu

- Preliminary specification for design input
- Specification for sample approval

POWERTIP TECH. CORP.

Headquarters:

No.8, 6th Road, Taichung Industrial Park,
Taichung, Taiwan
台中市 407 工業區六路 8 號

TEL: 886-4-2355-8168
FAX: 886-4-2355-8166

E-mail: sales@powertip.com.tw
[Http://www.powertip.com.tw](http://www.powertip.com.tw)

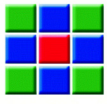

History of Version

Date (mm / dd / yyyy)	Ver.	Edi.	Description	Page	Design by
06/08/2017	01	001	New Drawing.	-	Terry
09/12/2017	01	002	New Sample	-	Terry
01/16/2018	01	003	Modify Sample Drawing	-	Terry
04/30/2018	01	004	Add AC Electrical Characteristics & Modify Initial code	14、15	Terry
07/26/2018	01	005	Modify Contrast ratio	6	Terry
2019/09/18	01	006	Modify Contrast ratio	4、6	Terry

Total: 44Page

Contents

1. SPECIFICATIONS

- 1.1 Features
- 1.2 Mechanical Specifications
- 1.3 Absolute Maximum Ratings
- 1.4 DC Electrical Characteristics
- 1.5 Optical Characteristics
- 1.6 Backlight Characteristics
- 1.7 Touch Panel Characteristics

2. MODULE STRUCTURE

- 2.1 Counter Drawing
- 2.2 Interface Pin Description
- 2.3 AC Characteristics
- 2.4 Refer Initial Code

3. QUALITY ASSURANCE SYSTEM

- 3.1 Quality Assurance Flow Chart
- 3.2 Inspection Specification

4. RELIABILITY TEST

- 4.1 Reliability Test Condition

5. PRECAUTION RELATING PRODUCT HANDLING

- 5.1 Safety
- 5.2 Handling
- 5.3 Storage
- 5.4 Terms of Warranty

Appendix : LCM Drawing.
LCM Packaging Specifications

1. SPECIFICATIONS

1.1 Features

Item	Standard Value
Display Type	720 * (RGB) * 1280
LCD Type	Full Viewing Angle , Normally Black , Transmissive type
Touch panel	True Multi-Touch Capacitive Touch Panel True Multi-touch with up to 10 Points of Absolution
Screen size(Inch)	7.0 Inch
Backlight Type	LED B/L
Weight	177.8 g
Control IC	ILI9881C (TFT Unit)
Interface	MIPI Interface (TFT Unit)
ROHS	THIS PRODUCT CONFORMS THE ROHS OF PTC Detail information please refer website : http://www.powertip.com.tw/news_detail.php?Key=1&cID=1

1.2 Mechanical Specifications

Item	Standard Value	Unit
Outline Dimension	189.32 (W) * 120.24 (L) * 5.31(H)	mm
Viewing Area	153.32 (W) * 90.21 (L)	mm
Active Area	152.32 (W) * 89.208 (L)	mm

Note : For detailed information please refer to LCM drawing.

1.3 Absolute Maximum Ratings

Item	Symbol	Condition	Min.	Max.	Unit	Remark
Supply Voltage	VDD	GND=0	-0.3	+3.8	V	-
	VCI		-0.3	+7.0	V	
Operating Temperature	T _{OP}	-	-20	+70	°C	
Storage Temperature	T _{ST}	-	-30	+80	°C	

1.4 DC Electrical Characteristics

GND = 0V, Ta = 25 °C

Item	Symbol	Min.	Typ.	Max.	Unit	Remark
Supply Voltage	VDD	3.0	3.3	3.6	V	Note2
	VCI	3.0	3.3	3.6		
Input signal Voltage	V _{IH}	0.7*VDD	-	VDD		
	V _{IL}	-0.3	-	0.3*VDD		
	V _{OH}	0.8*VDD	-	VDD		
	V _{OL}	0	-	0.2*VDD		
Supply Current	I _{VDD}	-	20mA	35mA		
	I _{VCI}	-	25mA	50mA		Note1

Note1: Maximum current display.

Note2 :For DSI DC level please refer to driver IC ILI9881C Specifications

1.5 Optical Characteristics

VDD= 3.3 V, Ta=25°C

Item	Symbol	Condition	Min.	Typ.	Max.	unit		
Response time	Tr +Tf	Ta = 25°C θX, θY = 0°	-	35	40	ms	Note 2	
Viewing angle	Top	θY+	CR ≥ 10	-	80	-	Deg.	Note 4
	Bottom	θY-		-	80	-		
	Left	θX-		-	80	-		
	Right	θX+		-	80	-		
Contrast ratio	CR		650	800	-		Note 3	
Color of CIE Coordinate (With B/L & touch panel)	White	X	Ta = 25°C θX , θY = 0°	0.308	0.358	0.408	-	Note1
		Y		0.315	0.365	0.415		
	Red	X		0.584	0.634	0.684		
		Y		0.273	0.323	0.373		
	Green	X		0.289	0.339	0.389		
		Y		0.534	0.584	0.634		
	Blue	X		0.094	0.144	0.194		
		Y		0.069	0.119	0.169		
Average Brightness Pattern=white display (With B/L & touch panel) *2	IV	IF=90mA	430	500	-	cd/m ²	Note1	
Uniformity (With B/L & touch panel) *1	△B		70	-	-	%	Note1	

Note 1:

*1 : $\Delta B = B(\text{min}) / B(\text{max}) * 100\%$

*2 : Measurement Condition for Optical Characteristics:

- a : Environment: $25^{\circ}\text{C} \pm 5^{\circ}\text{C}$ / $60 \pm 20\% \text{R.H}$, no wind , dark room below 10 Lux at typical lamp current and typical operating frequency.
- b : Measurement Distance: $500 \pm 50 \text{ mm}$, ($\theta = 0^{\circ}$)
- c : Equipment: TOPCON BM-7 fast , (field 1°) , after 10 minutes operation.
- d : The uncertainty of the C.I.E coordinate measurement ± 0.01 , Average Brightness $\pm 4\%$

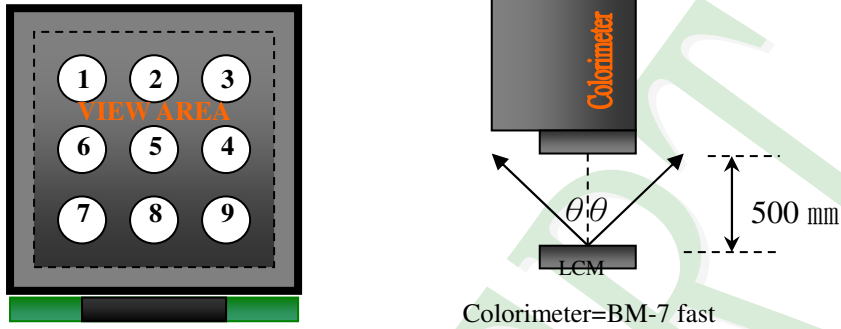

To be measured at the center area of panel with a viewing cone of 1° by Topcon luminance meter BM-7, after 10 minutes operation (module)

Note2: Definition of response time:

The output signals of photo detector are measured when the input signals are changed from "black" to "white"(falling time) and from "white" to "black"(rising time), respectively. The response time is defined as the time interval between the 10% and 90% of Amplitudes.

Refer to figure as below:

Normally White



Normally Black

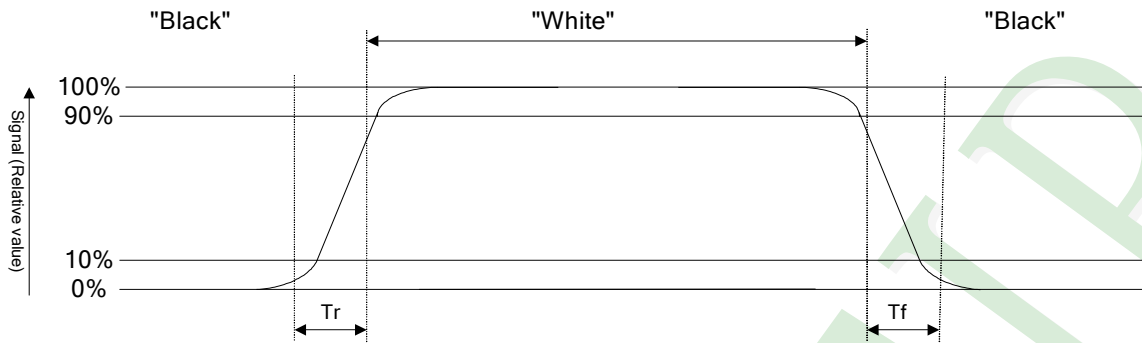

Note3: Definition of contrast ratio:

Contrast ratio is calculated with the following formula

$$\text{Contrast ratio (CR)} = \frac{\text{Photo detector output when LCD is at "White" state}}{\text{Photo detector output when LCD is at "Black" state}}$$

Note4: Definition of viewing angle:

Refer to figure as below:

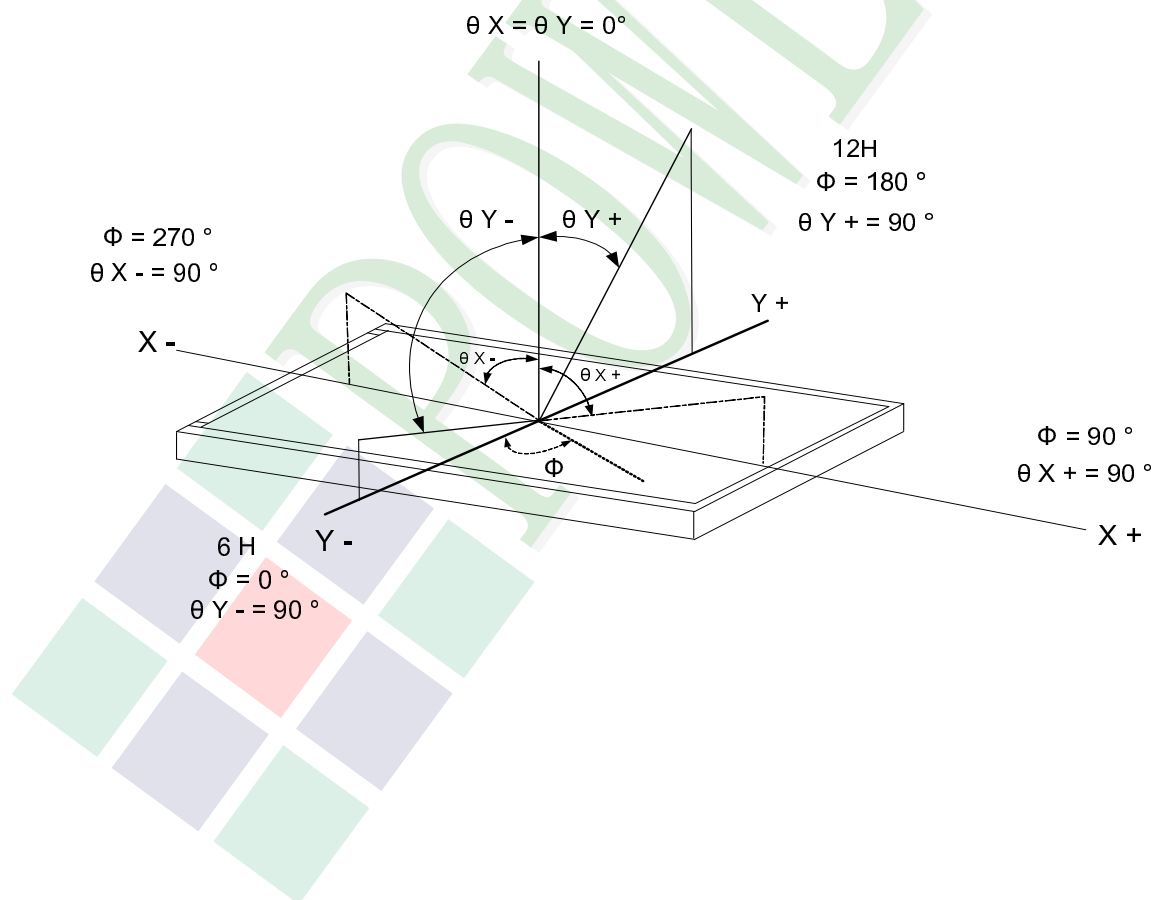

1.6 Backlight Characteristics

Electrical / Optical Characteristics

Item	Symbol	Min.	Typ.	Max.	Unit	Remark
Forward Voltage	V_f	16.2	19.2	21.0	V	Ta=25°C IF=90mA
Life time	-	20000	-	-	Hr	

LED Backlight Circuit:

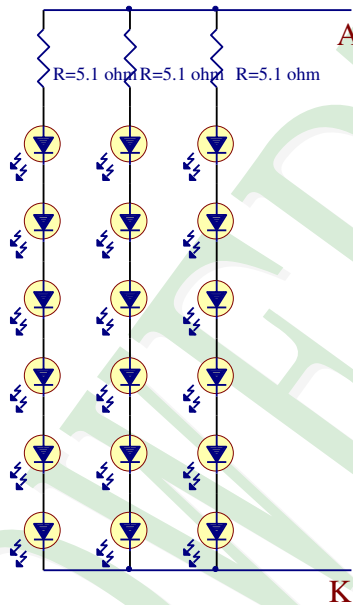

1.7 Touch Panel Characteristics

Item	Standard Value
Touch Panel Size	7"
Touch type	Projective Capacitive Touch Panel
Input Method	True Multi-touch with up to 10 Points of Absolution X and Y Coordinates
IC	FT5426
Output Interface	I2C
I2C Address	0X70

I²C Address

Bit 7	Bit 6	Bit 5	Bit 4	Bit 3	Bit 2	Bit 1	Bit 0
1	1	1	0	0	0	0	R/W

Bit 0: 0 for Write / 1 for Read

Mechanical Specifications

Item	Standard Value	Unit
Viewing Area	153.32 (W) * 90.21 (L)	mm
Number of sensing channel	25(TX) * 15 (RX)	

Absolute Maximum Ratings

Item	Symbol	Condition	Min.	Max.	Unit
Supply voltage	TPVDD	-	2.7	+3.6	V
Operating Temperature	T _{OP}	-	-20	+70	°C
Storage Temperature	T _{ST}	-	-30	+80	°C

DC Electrical Characteristics

Item	Symbol	Condition	Min.	Typ.	Max.	Unit
Power Supply Voltage	TPVDD	Ta=25°C	2.7	3.3	3.6	V
Input High Voltage	VIH		0.7 * TPVDD	-	TPVDD	V
Input Low Voltage	VIL		-0.3	-	0.3* TPVDD	V

2. MODULE STRUCTURE

2.1 Counter Drawing

2.1.1 LCM Mechanical Diagram

* See Appendix

2.1.2 Block Diagram

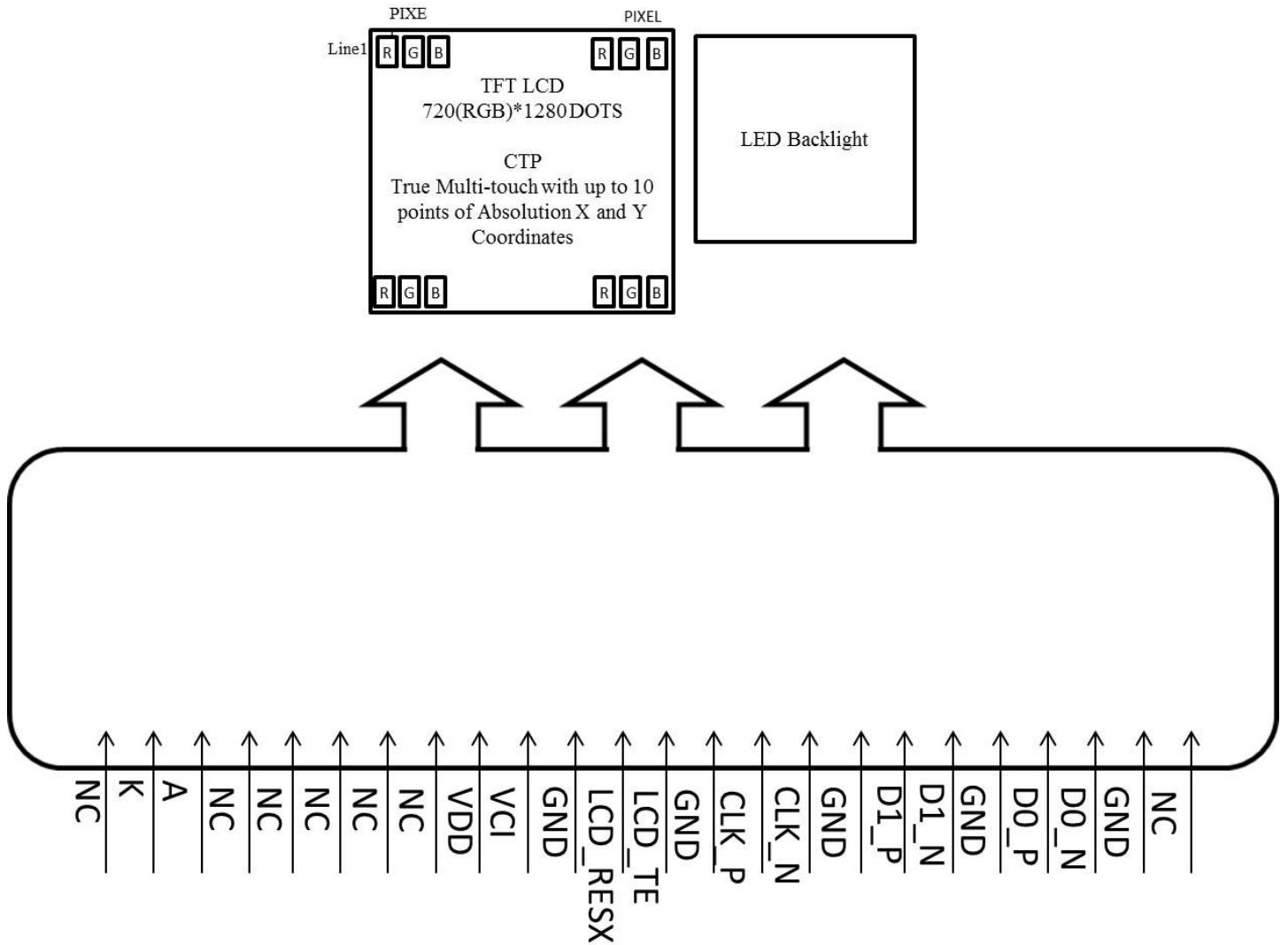

2.2 Interface Pin Description

Interface for TFT display :

Pin#	Name	DESCRIPTION
1	NC	No connection.
2	K	Power for LED backlight cathode input.
3	A	Power for LED backlight anode input.
4	NC	No connection.
5	NC	No connection.
6	GND	Ground
7	NC	No connection.
8	NC	No connection.
9	VDD	Power supply for internal logic regulator.
10	VCI	Power supply for analog circuit.
11	GND	Ground.
12	LCD_RESX	The external reset input Initializes the chip with a low input. Be sure to execute a power-on reset after supplying power.
13	LCD_TE	Tearing effect output pin.
14	GND	Ground.
15	CLK_P	MIPI DSI differential clock pair
16	CLK_N	MIPI DSI differential clock pair
17	GND	Ground.
18	D1_P	MIPI DSI differential data pair. (Data lane 1)
19	D1_N	MIPI DSI differential data pair. (Data lane 1)
20	GND	Ground.
21	D0_P	MIPI DSI differential data pair. (Data lane 0)
22	D0_N	MIPI DSI differential data pair. (Data lane 0)
23	GND	Ground.
24	NC	No connection.

Interface for CTP:

Pin#	Name	DESCRIPTION
1	RST	RESET.
2	SCL	I2C Data.
3	SDA	I2C Data.
4	INT	The interrupt from the CTP to the Host.
5	TPVDD	Power.
6	GND	Ground.

2.3 AC Electrical Characteristics

Timing for DSI video mode

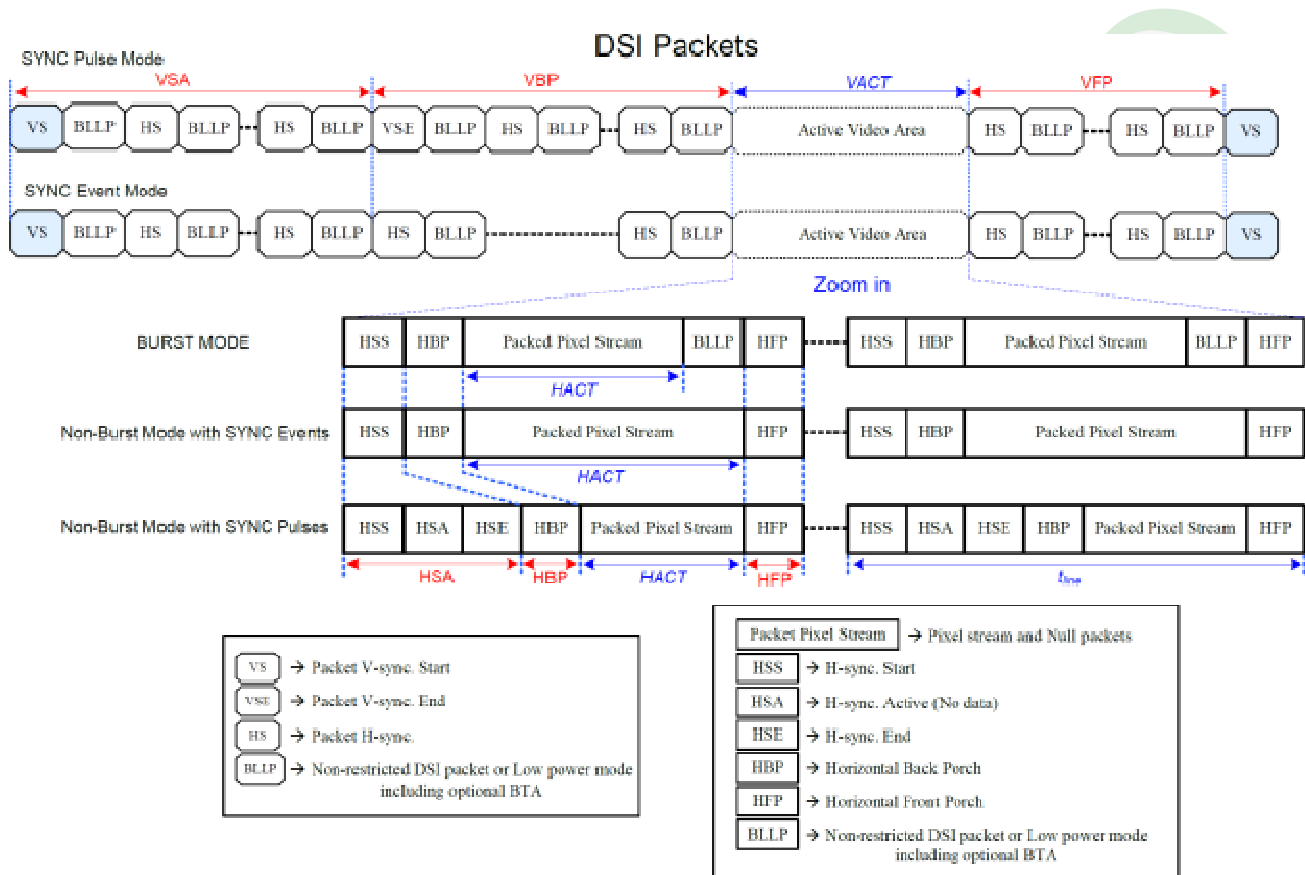

Parameters	Symbols	Min.	Typ.	Max.	Units
Vertical sync. active	VSA	2 <small>(Note 6)</small>	-	-	Line
Vertical Back Porch	VBP	14 <small>(Note 6)</small>	-	-	Line
Vertical Front Porch	VFP	8 <small>(Note 6)</small>	-	-	Line
Active lines per frame	VACT	-	1280	-	Line
Horizontal sync. active	HSA	2	-	-	Pixel
Horizontal Porch period	HSA + HBP + HFP	1.6	-	-	us
Active pixels per line	HACT	-	720	-	Pixel
Bit rate	BR _{bps}	385		Note 5	Mbps/lane

1 UI=1/Bit rate

$HSA(\text{pixel}) = (tHSA \times \text{lane number}) / (UI \times \text{pixel format})$

$HBP(\text{pixel}) = (tHBP \times \text{lane number}) / (UI \times \text{pixel format})$

$HFP(\text{pixel}) = (tHFP \times \text{lane number}) / (UI \times \text{pixel format})$

$$\text{Frame Rate} = \frac{BR_{\text{bps}} \times \text{Lane}_{\text{num}}}{(VACT+VSA+VBP+VFP) \times (HACT+HSA+HBP+HFP) \times \text{Pixel Format}}$$

Example : BR_{bps} = 457Mbps/lane, 1UI=2.1883ns, Frame rate=60Hz, VACT=1280, VSA=2, VBP=30, VFP=20, HACT=720, HSA=33, HBP=100, HFP=100, Lane_{num}=4(lane), Pixel Format=24(bit).

Note:

1. Lane_{num}: Data lane of MIPI-DSI.
2. Pixel Format: Please reference to "4.1 DSI System Interface".
3. The formula exists slightly error because of the host-transmission way.
4. The best frame rate setting : 2 data lanes : 50~60 Hz / 3 data lanes : 50~70 Hz / 4 data lanes : 50~70 Hz.
5. Please reference to "Table 39: Limited Clock Channel Speed".
6. The minimum values of this table mean the limitation of IC without considering the panel GIP. The actual values of VSA, VBP and VFP will be changed by different panel GIP setting.

2.4 Refer Initial Code

```
Void ILI9881C_D-AM30841F-00_Initial Code(Void)
```

```
{  
  
LCD_nRESET = 1;  
  
Delaysms(1); // Delay 1ms  
  
LCD_nRESET = 0;  
  
Delaysms(1); // Delay 1ms // This Delay time is necessary  
  
LCD_nRESET = 1;  
  
Delaysms(10); // Delay 120 ms  
  
//***** Start Initial Sequence *****//  
  
LCD_ILI9881C_CMD(0xFF);  
  
LCD_ILI9881C_INDEX(0x98);  
  
LCD_ILI9881C_INDEX(0x81);  
  
LCD_ILI9881C_INDEX(0x03);  
  
LCD_ILI9881C_CMD(0x01);  
  
LCD_ILI9881C_INDEX(0x00);  
  
LCD_ILI9881C_CMD(0x02);
```

LCD_ILI9881C_INDEX(0x00);

LCD_ILI9881C_CMD(0x03);

LCD_ILI9881C_INDEX(0x55);

LCD_ILI9881C_CMD(0x04);

LCD_ILI9881C_INDEX(0x13);

LCD_ILI9881C_CMD(0x05);

LCD_ILI9881C_INDEX(0x00);

LCD_ILI9881C_CMD(0x06);

LCD_ILI9881C_INDEX(0x06);

LCD_ILI9881C_CMD(0x07);

LCD_ILI9881C_INDEX(0x01);

LCD_ILI9881C_CMD(0x08);

LCD_ILI9881C_INDEX(0x00);

LCD_ILI9881C_CMD(0x09);

LCD_ILI9881C_INDEX(0x01);

LCD_ILI9881C_CMD(0x0A);

LCD_ILI9881C_INDEX(0x01);

LCD_ILI9881C_CMD(0x0B);

LCD_ILI9881C_INDEX(0x00);

LCD_ILI9881C_CMD(0x0C);

LCD_ILI9881C_INDEX(0x00);

LCD_ILI9881C_CMD(0x0D);

LCD_ILI9881C_INDEX(0x00);

LCD_ILI9881C_CMD(0x0E);

LCD_ILI9881C_INDEX(0x00);

LCD_ILI9881C_CMD(0x0F);

LCD_ILI9881C_INDEX(0x18);

LCD_ILI9881C_CMD(0x10);

LCD_ILI9881C_INDEX(0x18);

LCD_ILI9881C_CMD(0x11);

LCD_ILI9881C_INDEX(0x00);

LCD_ILI9881C_CMD(0x12);

LCD_ILI9881C_INDEX(0x00);

LCD_ILI9881C_CMD(0x13);

LCD_ILI9881C_INDEX(0x00);

LCD_ILI9881C_CMD(0x14);

LCD_ILI9881C_INDEX(0x00);

LCD_ILI9881C_CMD(0x15);

LCD_ILI9881C_INDEX(0x00);

LCD_ILI9881C_CMD(0x16);

LCD_ILI9881C_INDEX(0x00);

LCD_ILI9881C_CMD(0x17);

LCD_ILI9881C_INDEX(0x00);

LCD_ILI9881C_CMD(0x18);

LCD_ILI9881C_INDEX(0x00);

LCD_ILI9881C_CMD(0x19);

LCD_ILI9881C_INDEX(0x00);

LCD_ILI9881C_CMD(0x1A);

LCD_ILI9881C_INDEX(0x00);

LCD_ILI9881C_CMD(0x1B);

LCD_ILI9881C_INDEX(0x00);

LCD_ILI9881C_CMD(0x1C);

LCD_ILI9881C_INDEX(0x00);

LCD_ILI9881C_CMD(0x1D);

LCD_ILI9881C_INDEX(0x00);

LCD_ILI9881C_CMD(0x1E);

LCD_ILI9881C_INDEX(0x44);

LCD_ILI9881C_CMD(0x1F);

LCD_ILI9881C_INDEX(0x80);

LCD_ILI9881C_CMD(0x20);

LCD_ILI9881C_INDEX(0x02);

LCD_ILI9881C_CMD(0x21);

LCD_ILI9881C_INDEX(0x03);

LCD_ILI9881C_CMD(0x22);

LCD_ILI9881C_INDEX(0x00);

LCD_ILI9881C_CMD(0x23);

LCD_ILI9881C_INDEX(0x00);

LCD_ILI9881C_CMD(0x24);

LCD_ILI9881C_INDEX(0x00);

LCD_ILI9881C_CMD(0x25);

LCD_ILI9881C_INDEX(0x00);

LCD_ILI9881C_CMD(0x26);

LCD_ILI9881C_INDEX(0x00);

LCD_ILI9881C_CMD(0x27);

LCD_ILI9881C_INDEX(0x00);

LCD_ILI9881C_CMD(0x28);

LCD_ILI9881C_INDEX(0x33);

LCD_ILI9881C_CMD(0x29);

LCD_ILI9881C_INDEX(0x03);

LCD_ILI9881C_CMD(0x2A);

LCD_ILI9881C_INDEX(0x00);

LCD_ILI9881C_CMD(0x2B);

LCD_ILI9881C_INDEX(0x00);

LCD_ILI9881C_CMD(0x2C);

LCD_ILI9881C_INDEX(0x00);

LCD_ILI9881C_CMD(0x2D);

LCD_ILI9881C_INDEX(0x00);

LCD_ILI9881C_CMD(0x2E);

LCD_ILI9881C_INDEX(0x00);

LCD_ILI9881C_CMD(0x2F);

LCD_ILI9881C_INDEX(0x00);

LCD_ILI9881C_CMD(0x30);

LCD_ILI9881C_INDEX(0x00);

LCD_ILI9881C_CMD(0x31);

LCD_ILI9881C_INDEX(0x00);

LCD_ILI9881C_CMD(0x32);

LCD_ILI9881C_INDEX(0x00);

LCD_ILI9881C_CMD(0x33);

LCD_ILI9881C_INDEX(0x00);

LCD_ILI9881C_CMD(0x34);

LCD_ILI9881C_INDEX(0x04);

LCD_ILI9881C_CMD(0x35);

LCD_ILI9881C_INDEX(0x00);

LCD_ILI9881C_CMD(0x36);

LCD_ILI9881C_INDEX(0x00);

LCD_ILI9881C_CMD(0x37);

LCD_ILI9881C_INDEX(0x00);

LCD_ILI9881C_CMD(0x38);

LCD_ILI9881C_INDEX(0x01);

LCD_ILI9881C_CMD(0x39);

LCD_ILI9881C_INDEX(0x00);

LCD_ILI9881C_CMD(0x3A);

LCD_ILI9881C_INDEX(0x00);

LCD_ILI9881C_CMD(0x3B);

LCD_ILI9881C_INDEX(0x00);

LCD_ILI9881C_CMD(0x3C);

LCD_ILI9881C_INDEX(0x00);

LCD_ILI9881C_CMD(0x3D);

LCD_ILI9881C_INDEX(0x00);

LCD_ILI9881C_CMD(0x3E);

LCD_ILI9881C_INDEX(0x00);

LCD_ILI9881C_CMD(0x3F);

LCD_ILI9881C_INDEX(0x00);

LCD_ILI9881C_CMD(0x40);

LCD_ILI9881C_INDEX(0x00);

LCD_ILI9881C_CMD(0x41);

LCD_ILI9881C_INDEX(0x00);

LCD_ILI9881C_CMD(0x42);

LCD_ILI9881C_INDEX(0x00);

LCD_ILI9881C_CMD(0x43);

LCD_ILI9881C_INDEX(0x00);

LCD_ILI9881C_CMD(0x44);

LCD_ILI9881C_INDEX(0x00);

LCD_ILI9881C_CMD(0x50);

LCD_ILI9881C_INDEX(0x01);

LCD_ILI9881C_CMD(0x51);

LCD_ILI9881C_INDEX(0x23);

LCD_ILI9881C_CMD(0x52);

LCD_ILI9881C_INDEX(0x45);

LCD_ILI9881C_CMD(0x53);

LCD_ILI9881C_INDEX(0x67);

LCD_ILI9881C_CMD(0x54);

LCD_ILI9881C_INDEX(0x89);

LCD_ILI9881C_CMD(0x55);

LCD_ILI9881C_INDEX(0xAB);

LCD_ILI9881C_CMD(0x56);

LCD_ILI9881C_INDEX(0x01);

LCD_ILI9881C_CMD(0x57);

LCD_ILI9881C_INDEX(0x23);

LCD_ILI9881C_CMD(0x58);

LCD_ILI9881C_INDEX(0x45);

LCD_ILI9881C_CMD(0x59);

LCD_ILI9881C_INDEX(0x67);

LCD_ILI9881C_CMD(0x5A);

LCD_ILI9881C_INDEX(0x89);

LCD_ILI9881C_CMD(0x5B);

LCD_ILI9881C_INDEX(0xAB);

LCD_ILI9881C_CMD(0x5C);

LCD_ILI9881C_INDEX(0xCD);

LCD_ILI9881C_CMD(0x5D);

LCD_ILI9881C_INDEX(0xEF);

LCD_ILI9881C_CMD(0x5E);

LCD_ILI9881C_INDEX(0x11);

LCD_ILI9881C_CMD(0x5F);

LCD_ILI9881C_INDEX(0x14);

LCD_ILI9881C_CMD(0x60);

LCD_ILI9881C_INDEX(0x15);

LCD_ILI9881C_CMD(0x61);

LCD_ILI9881C_INDEX(0x0F);

LCD_ILI9881C_CMD(0x62);

LCD_ILI9881C_INDEX(0x0D);

LCD_ILI9881C_CMD(0x63);

LCD_ILI9881C_INDEX(0x0E);

LCD_ILI9881C_CMD(0x64);

LCD_ILI9881C_INDEX(0x0C);

LCD_ILI9881C_CMD(0x65);

LCD_ILI9881C_INDEX(0x06);

LCD_ILI9881C_CMD(0x66);

LCD_ILI9881C_INDEX(0x02);

LCD_ILI9881C_CMD(0x67);

LCD_ILI9881C_INDEX(0x02);

LCD_ILI9881C_CMD(0x68);

LCD_ILI9881C_INDEX(0x02);

LCD_ILI9881C_CMD(0x69);

LCD_ILI9881C_INDEX(0x02);

LCD_ILI9881C_CMD(0x6A);

LCD_ILI9881C_INDEX(0x02);

LCD_ILI9881C_CMD(0x6B);

LCD_ILI9881C_INDEX(0x02);

LCD_ILI9881C_CMD(0x6C);

LCD_ILI9881C_INDEX(0x02);

LCD_ILI9881C_CMD(0x6D);

LCD_ILI9881C_INDEX(0x02);

LCD_ILI9881C_CMD(0x6E);

LCD_ILI9881C_INDEX(0x02);

LCD_ILI9881C_CMD(0x6F);

LCD_ILI9881C_INDEX(0x02);

LCD_ILI9881C_CMD(0x70);

LCD_ILI9881C_INDEX(0x02);

LCD_ILI9881C_CMD(0x71);

LCD_ILI9881C_INDEX(0x00);

LCD_ILI9881C_CMD(0x72);

LCD_ILI9881C_INDEX(0x01);

LCD_ILI9881C_CMD(0x73);

LCD_ILI9881C_INDEX(0x08);

LCD_ILI9881C_CMD(0x74);

LCD_ILI9881C_INDEX(0x02);

LCD_ILI9881C_CMD(0x75);

LCD_ILI9881C_INDEX(0x14);

LCD_ILI9881C_CMD(0x76);

LCD_ILI9881C_INDEX(0x15);

LCD_ILI9881C_CMD(0x77);

LCD_ILI9881C_INDEX(0x0F);

LCD_ILI9881C_CMD(0x78);

LCD_ILI9881C_INDEX(0x0D);

LCD_ILI9881C_CMD(0x79);

LCD_ILI9881C_INDEX(0x0E);

LCD_ILI9881C_CMD(0x7A);

LCD_ILI9881C_INDEX(0x0C);

LCD_ILI9881C_CMD(0x7B);

LCD_ILI9881C_INDEX(0x08);

LCD_ILI9881C_CMD(0x7C);

LCD_ILI9881C_INDEX(0x02);

LCD_ILI9881C_CMD(0x7D);

LCD_ILI9881C_INDEX(0x02);

LCD_ILI9881C_CMD(0x7E);

LCD_ILI9881C_INDEX(0x02);

LCD_ILI9881C_CMD(0x7F);

LCD_ILI9881C_INDEX(0x02);

LCD_ILI9881C_CMD(0x80);

LCD_ILI9881C_INDEX(0x02);

LCD_ILI9881C_CMD(0x81);

LCD_ILI9881C_INDEX(0x02);

LCD_ILI9881C_CMD(0x82);

LCD_ILI9881C_INDEX(0x02);

LCD_ILI9881C_CMD(0x83);

LCD_ILI9881C_INDEX(0x02);

LCD_ILI9881C_CMD(0x84);

LCD_ILI9881C_INDEX(0x02);

LCD_ILI9881C_CMD(0x85);

LCD_ILI9881C_INDEX(0x02);

LCD_ILI9881C_CMD(0x86);

LCD_ILI9881C_INDEX(0x02);

LCD_ILI9881C_CMD(0x87);

LCD_ILI9881C_INDEX(0x00);

LCD_ILI9881C_CMD(0x88)

LCD_ILI9881C_INDEX(0x01);

LCD_ILI9881C_CMD(0x89);

LCD_ILI9881C_INDEX(0x06);

LCD_ILI9881C_CMD(0x8A);

LCD_ILI9881C_INDEX(0x02);

LCD_ILI9881C_CMD(0xFF);

LCD_ILI9881C_INDEX(0x98);

LCD_ILI9881C_INDEX(0x81);

LCD_ILI9881C_INDEX(0x04);

LCD_ILI9881C_CMD(0x6C);

LCD_ILI9881C_INDEX(0x15);

LCD_ILI9881C_CMD(0x6E);

LCD_ILI9881C_INDEX(0x2A);

LCD_ILI9881C_CMD(0x6F);

LCD_ILI9881C_INDEX(0x33);

LCD_ILI9881C_CMD(0x3A);

LCD_ILI9881C_INDEX(0x24);

LCD_ILI9881C_CMD(0x8D);

LCD_ILI9881C_INDEX(0x14);

LCD_ILI9881C_CMD(0x87);

LCD_ILI9881C_INDEX(0xBA);

LCD_ILI9881C_CMD(0x26);

LCD_ILI9881C_INDEX(0x76);

LCD_ILI9881C_CMD(0xB2);

LCD_ILI9881C_INDEX(0xD1);

LCD_ILI9881C_CMD(0xB5);

LCD_ILI9881C_INDEX(0xD7);

LCD_ILI9881C_CMD(0x35);

LCD_ILI9881C_INDEX(0x1F);

LCD_ILI9881C_CMD(0xFF);

LCD_ILI9881C_INDEX(0x98);

LCD_ILI9881C_INDEX(0x81);

LCD_ILI9881C_INDEX(0x01);

LCD_ILI9881C_CMD(0x22);

LCD_ILI9881C_INDEX(0x0A);

LCD_ILI9881C_CMD(0x53);

LCD_ILI9881C_INDEX(0x72);

LCD_ILI9881C_CMD(0x55);

LCD_ILI9881C_INDEX(0x77);

LCD_ILI9881C_CMD(0x50);

LCD_ILI9881C_INDEX(0xA6);

LCD_ILI9881C_CMD(0x51);

LCD_ILI9881C_INDEX(0xA6);

LCD_ILI9881C_CMD(0x31);

LCD_ILI9881C_INDEX(0x00);

LCD_ILI9881C_CMD(0x60);

LCD_ILI9881C_INDEX(0x20);

LCD_ILI9881C_CMD(0xA0);

LCD_ILI9881C_INDEX(0x08);

LCD_ILI9881C_CMD(0xA1);

LCD_ILI9881C_INDEX(0x1A);

LCD_ILI9881C_CMD(0xA2);

LCD_ILI9881C_INDEX(0x2A);

LCD_ILI9881C_CMD(0xA3);

LCD_ILI9881C_INDEX(0x14);

LCD_ILI9881C_CMD(0xA4);

LCD_ILI9881C_INDEX(0x17);

LCD_ILI9881C_CMD(0xA5);

LCD_ILI9881C_INDEX(0x2B);

LCD_ILI9881C_CMD(0xA6);

LCD_ILI9881C_INDEX(0x1D);

LCD_ILI9881C_CMD(0xA7);

LCD_ILI9881C_INDEX(0x20);

LCD_ILI9881C_CMD(0xA8);

LCD_ILI9881C_INDEX(0x9D);

LCD_ILI9881C_CMD(0xA9);

LCD_ILI9881C_INDEX(0x1C);

LCD_ILI9881C_CMD(0xAA);

LCD_ILI9881C_INDEX(0x29);

LCD_ILI9881C_CMD(0xAB);

LCD_ILI9881C_INDEX(0x8F);

LCD_ILI9881C_CMD(0xAC);

LCD_ILI9881C_INDEX(0x20);

LCD_ILI9881C_CMD(0xAD);

LCD_ILI9881C_INDEX(0x1F);

LCD_ILI9881C_CMD(0xAE);

LCD_ILI9881C_INDEX(0x4F);

LCD_ILI9881C_CMD(0xAF);

LCD_ILI9881C_INDEX(0x23);

LCD_ILI9881C_CMD(0xB0);

LCD_ILI9881C_INDEX(0x29);

LCD_ILI9881C_CMD(0xB1);

LCD_ILI9881C_INDEX(0x56);

LCD_ILI9881C_CMD(0xB2);

LCD_ILI9881C_INDEX(0x66);

LCD_ILI9881C_CMD(0xB3);

LCD_ILI9881C_INDEX(0x39);

LCD_ILI9881C_CMD(0xC0);

LCD_ILI9881C_INDEX(0x08);

LCD_ILI9881C_CMD(0xC1);

LCD_ILI9881C_INDEX(0x1A);

LCD_ILI9881C_CMD(0xC2);

LCD_ILI9881C_INDEX(0x2A);

LCD_ILI9881C_CMD(0xC3);

LCD_ILI9881C_INDEX(0x15);

LCD_ILI9881C_CMD(0xC4);

LCD_ILI9881C_INDEX(0x17);

LCD_ILI9881C_CMD(0xC5);

LCD_ILI9881C_INDEX(0x2B);

LCD_ILI9881C_CMD(0xC6);

LCD_ILI9881C_INDEX(0x1D);

LCD_ILI9881C_CMD(0xC7);

LCD_ILI9881C_INDEX(0x20);

LCD_ILI9881C_CMD(0xC8);

LCD_ILI9881C_INDEX(0x9D);

LCD_ILI9881C_CMD(0xC9);

LCD_ILI9881C_INDEX(0x1D);

LCD_ILI9881C_CMD(0xCA);

LCD_ILI9881C_INDEX(0x29);

LCD_ILI9881C_CMD(0xCB);

LCD_ILI9881C_INDEX(0x8F);

LCD_ILI9881C_CMD(0xCC);

LCD_ILI9881C_INDEX(0x20);

LCD_ILI9881C_CMD(0xCD);

LCD_ILI9881C_INDEX(0x1F);

LCD_ILI9881C_CMD(0xCE);

LCD_ILI9881C_INDEX(0x4F);

LCD_ILI9881C_CMD(0xCF);

LCD_ILI9881C_INDEX(0x24);

LCD_ILI9881C_CMD(0xD0);

LCD_ILI9881C_INDEX(0x29);

LCD_ILI9881C_CMD(0xD1);

LCD_ILI9881C_INDEX(0x56);

LCD_ILI9881C_CMD(0xD2);

LCD_ILI9881C_INDEX(0x66);

LCD_ILI9881C_CMD(0xD3);

LCD_ILI9881C_INDEX(0x39);

LCD_ILI9881C_CMD(0xFF);

```
LCD_ILI9881C_INDEX(0x98);
```

```
LCD_ILI9881C_INDEX(0x81);
```

```
LCD_ILI9881C_INDEX(0x00);
```

```
LCD_ILI9881C_CMD(0x11);
```

```
LCD_ILI9881C_INDEX(0x00);
```

```
Void ILI9881C_EnterSleep_Code(Void)
```

```
{
```

```
LCD_ILI9881C_CMD(0x28) //Display oFF
```

```
Delaysms(20);
```

```
LCD_ILI9881C_CMD(0x10); // Internal oscillator will be stopped
```

```
Delaysms(120);
```

```
}
```

```
Void ILI9881C_ExitSleep_Code(Void)
```

```
{
```

```
LCD_ILI9881C_CMD(0x11); // Sleep Out
```

```
Delaysms(120);
```

```
LCD_ILI9881C_CMD(0x29) //Display on
```

```
Delaysms(20);
```

```
}
```

3. QUALITY ASSURANCE SYSTEM

3.1 Quality Assurance Flow Chart

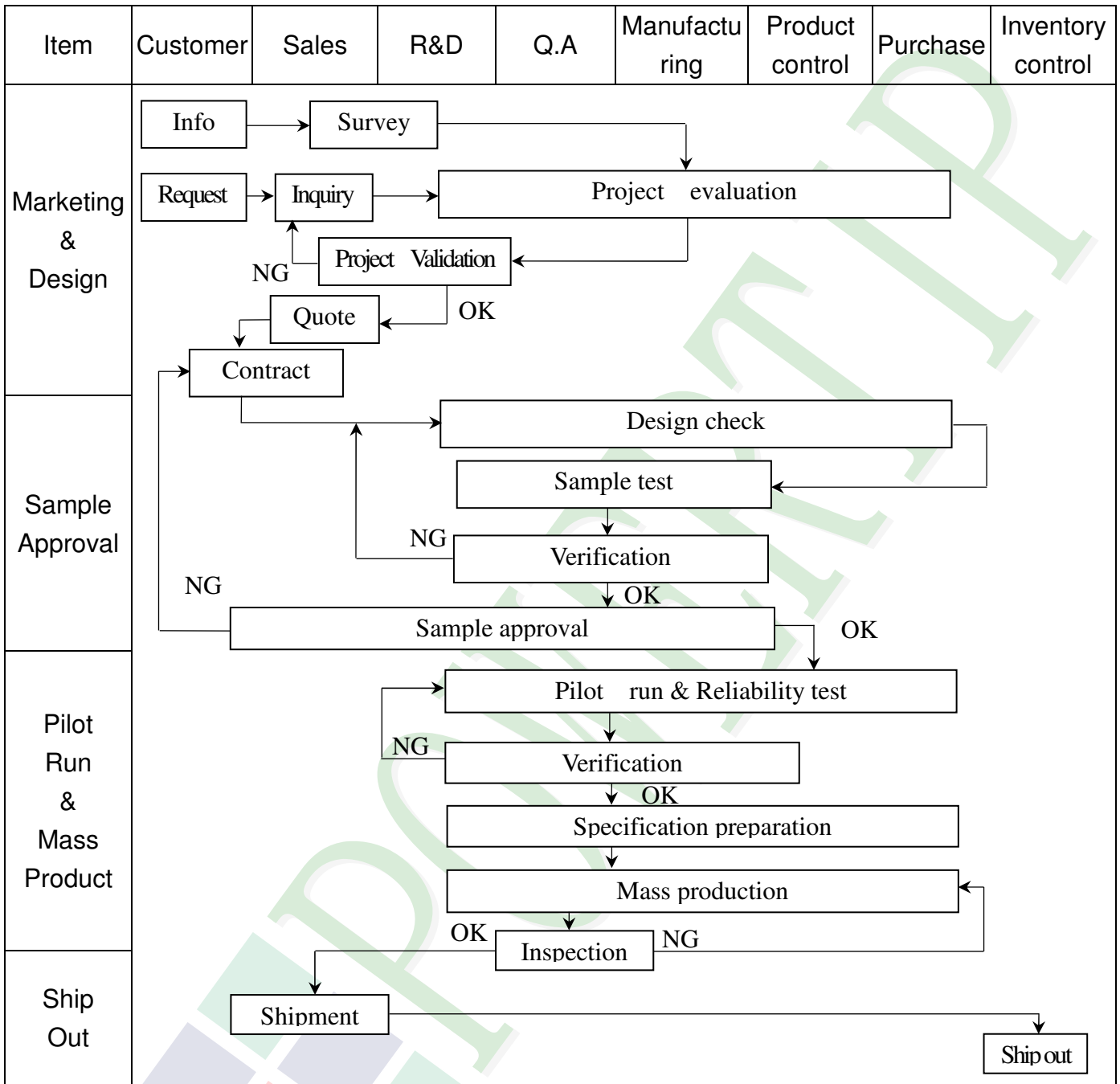

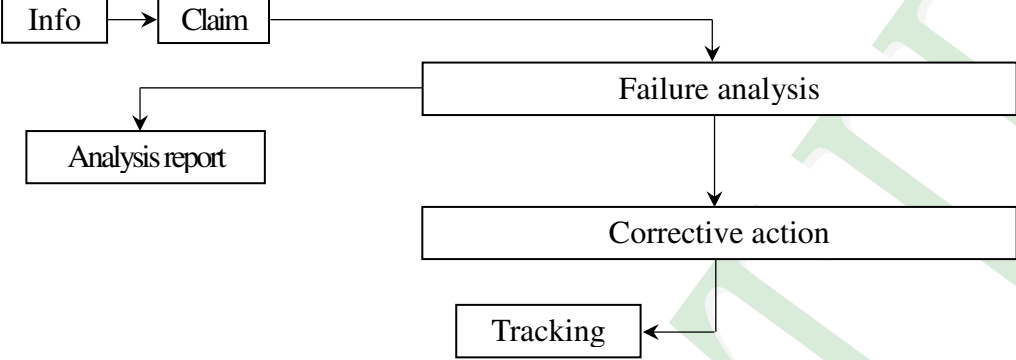
Item	Customer	Sales	R&D	Q.A	Manufacturing	Product control	Purchase	Inventory control
Sales Service	 <pre> graph TD Info[Info] --> Claim[Claim] Claim --> FA[Failure analysis] Claim --> AR[Analysis report] FA --> CA[Corrective action] CA --> Tracking[Tracking] </pre>							
Q.A Activity	1. ISO 9001 Maintenance Activities 3. Equipment calibration 5. Standardization Management				2. Process improvement proposal 4. Education And Training Activities			

3.2. Inspection Specification

- ◆Scope : The document shall be applied to TFT-LCD Module for 3.5" ~15" (Ver.B01).
- ◆Inspection Standard : MIL-STD-105E Table Normal Inspection Single Sampling Level II.
- ◆Equipment : Gauge 、 MIL-STD 、 Powertip Tester 、 Sample
- ◆Defect Level : Major Defect AQL : 0.4 ; Minor Defect AQL : 1.5
- ◆OUT Going Defect Level : Sampling.
- ◆Standard of the product appearance test :

a. Manner of appearance test :

- (1). The test best be under 20W×2 fluorescent light , and distance of view must be at 30 cm.
- (2). The test direction is base on about around 45° of vertical line.

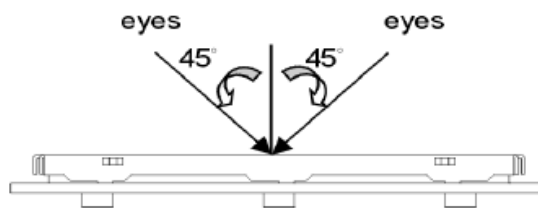

(3). Definition of area.

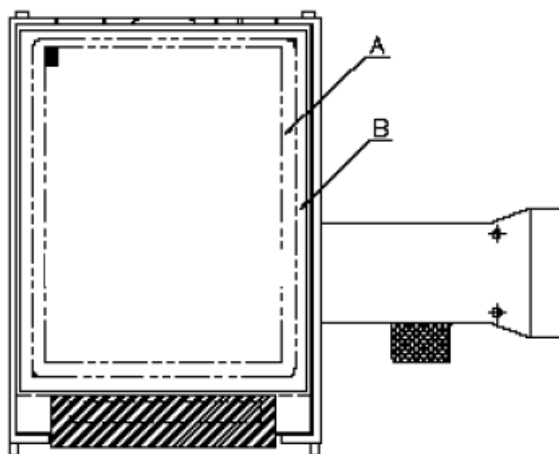

A area : viewing area

B area : Outside of viewing area

(4). Standard of inspection : (Unit : mm)

◆Specification For TFT-LCD Module 3.5" ~15" :

(Ver.B01)

NO	Item	Criterion	Level												
01	Product condition	1. 1 The part number is inconsistent with work order of production.	Major												
		1. 2 Mixed product types.	Major												
		1. 3 Assembled in inverse direction.	Major												
02	Quantity	2. 1 The quantity is inconsistent with work order of production.	Major												
03	Outline dimension	3. 1 Product dimension and structure must conform to structure diagram.	Major												
04	Electrical Testing	4. 1 Missing line character and icon.	Major												
		4. 2 No function or no display.	Major												
		4. 3 Display malfunction.	Major												
		4. 4 LCD viewing angle defect.	Major												
		4. 5 Current consumption exceeds product specifications.	Major												
		4. 6 Mura can not be seen through 5% ND filter. (Mura : Under the normal examination angle of view, the picture has the non-uniform phenomenon.)	Minor												
05	Dot defect (Bright dot 、 Dark dot) On -display	<table border="1" style="margin-left: auto; margin-right: auto;"> <thead> <tr> <th colspan="2">Item</th> <th>Acceptance (Q'ty)</th> </tr> </thead> <tbody> <tr> <td rowspan="4" style="text-align: center; vertical-align: middle;">Dot Defect</td> <td style="text-align: center;">Bright Dot</td> <td style="text-align: center;">≤ 4</td> </tr> <tr> <td style="text-align: center;">Dark Dot</td> <td style="text-align: center;">≤ 5</td> </tr> <tr> <td style="text-align: center;">Joint Dot</td> <td style="text-align: center;">≤ 3</td> </tr> <tr> <td style="text-align: center;">Total</td> <td style="text-align: center;">≤ 7</td> </tr> </tbody> </table> <p>5. 1 Inspection pattern : full white , full black , Red , Green and blue screens.</p> <p>5. 2 It is defined as dot defect if defect area $> 1/2$ dot.</p> <p>5. 3 The distance between two dot defect ≥ 5 mm.</p> <p>5. 4 Bright dot that can not be seen through 5% ND filter.</p>	Item		Acceptance (Q'ty)	Dot Defect	Bright Dot	≤ 4	Dark Dot	≤ 5	Joint Dot	≤ 3	Total	≤ 7	Minor
Item		Acceptance (Q'ty)													
Dot Defect	Bright Dot	≤ 4													
	Dark Dot	≤ 5													
	Joint Dot	≤ 3													
	Total	≤ 7													

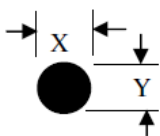
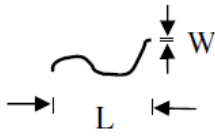

◆Specification For TFT-LCD Module 3.5" ~15" :

(Ver.B01)

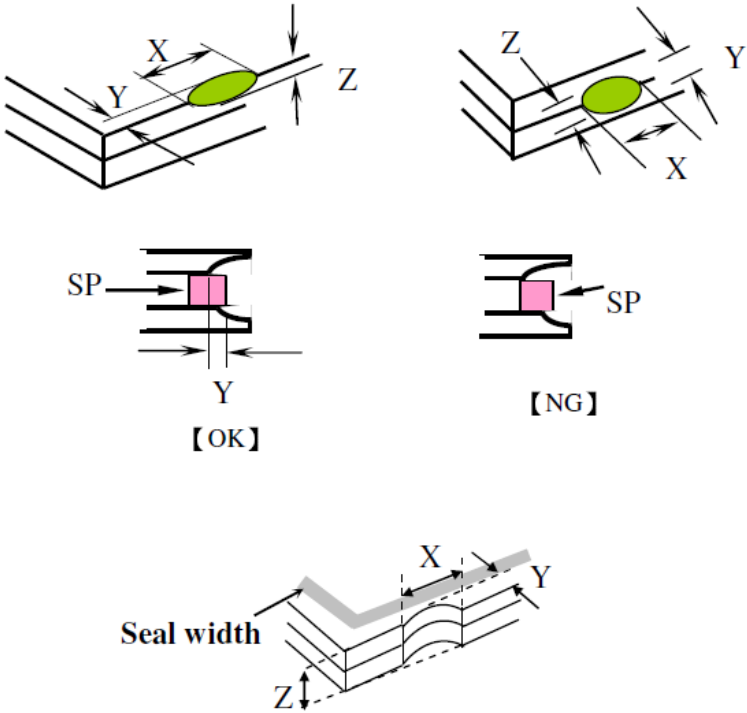
NO	Item	Criterion	Level																																																					
06	Black or white dot、scratch、contamination Round type  $\Phi = (x + y) / 2$ Line type 	<p>6.1 Round type (Non-display or display) :</p> <table border="1" data-bbox="526 459 1284 728"> <thead> <tr> <th rowspan="2">Dimension (diameter : Φ)</th> <th colspan="2">Acceptance (Q'ty)</th> </tr> <tr> <th>A area</th> <th>B area</th> </tr> </thead> <tbody> <tr> <td>$\Phi \leq 0.25$</td> <td colspan="2">Ignore</td> </tr> <tr> <td>$0.25 < \Phi \leq 0.50$</td> <td>5</td> <td rowspan="3">Ignore</td> </tr> <tr> <td>$\Phi > 0.50$</td> <td>0</td> </tr> <tr> <td>Total</td> <td>5</td> </tr> </tbody> </table> <p>6.2 Line type(Non-display or display) :</p> <table border="1" data-bbox="454 851 1356 1377"> <thead> <tr> <th rowspan="2">module size</th> <th rowspan="2">Length (L)</th> <th rowspan="2">Width (W)</th> <th colspan="2">Acceptance (Q'ty)</th> </tr> <tr> <th>A area</th> <th>B area</th> </tr> </thead> <tbody> <tr> <td rowspan="5">3.5" to less 9"</td> <td>---</td> <td>$W \leq 0.03$</td> <td>Ignore</td> <td rowspan="5">Ignore</td> </tr> <tr> <td>$L \leq 10.0$</td> <td>$0.03 < W \leq 0.05$</td> <td>4</td> </tr> <tr> <td>$L \leq 5.0$</td> <td>$0.05 < W \leq 0.10$</td> <td>2</td> </tr> <tr> <td>---</td> <td>$W > 0.10$</td> <td>As round type</td> </tr> <tr> <td colspan="2">Total</td> <td>5</td> </tr> <tr> <td rowspan="5">9" to 15"</td> <td>---</td> <td>$W \leq 0.05$</td> <td>Ignore</td> <td rowspan="5">Ignore</td> </tr> <tr> <td>$L \leq 10.0$</td> <td>$0.05 < W \leq 0.10$</td> <td>5</td> </tr> <tr> <td>---</td> <td>$W > 0.10$</td> <td>As round type</td> </tr> <tr> <td colspan="2">Total</td> <td>5</td> </tr> </tbody> </table>	Dimension (diameter : Φ)	Acceptance (Q'ty)		A area	B area	$\Phi \leq 0.25$	Ignore		$0.25 < \Phi \leq 0.50$	5	Ignore	$\Phi > 0.50$	0	Total	5	module size	Length (L)	Width (W)	Acceptance (Q'ty)		A area	B area	3.5" to less 9"	---	$W \leq 0.03$	Ignore	Ignore	$L \leq 10.0$	$0.03 < W \leq 0.05$	4	$L \leq 5.0$	$0.05 < W \leq 0.10$	2	---	$W > 0.10$	As round type	Total		5	9" to 15"	---	$W \leq 0.05$	Ignore	Ignore	$L \leq 10.0$	$0.05 < W \leq 0.10$	5	---	$W > 0.10$	As round type	Total		5	Minor
Dimension (diameter : Φ)	Acceptance (Q'ty)																																																							
	A area	B area																																																						
$\Phi \leq 0.25$	Ignore																																																							
$0.25 < \Phi \leq 0.50$	5	Ignore																																																						
$\Phi > 0.50$	0																																																							
Total	5																																																							
module size	Length (L)	Width (W)	Acceptance (Q'ty)																																																					
			A area	B area																																																				
3.5" to less 9"	---	$W \leq 0.03$	Ignore	Ignore																																																				
	$L \leq 10.0$	$0.03 < W \leq 0.05$	4																																																					
	$L \leq 5.0$	$0.05 < W \leq 0.10$	2																																																					
	---	$W > 0.10$	As round type																																																					
	Total		5																																																					
9" to 15"	---	$W \leq 0.05$	Ignore	Ignore																																																				
	$L \leq 10.0$	$0.05 < W \leq 0.10$	5																																																					
	---	$W > 0.10$	As round type																																																					
	Total		5																																																					
	07	Polarizer Bubble	<table border="1" data-bbox="494 1512 1316 1915"> <thead> <tr> <th rowspan="2">Dimension (diameter : Φ)</th> <th colspan="2">Acceptance (Q'ty)</th> </tr> <tr> <th>A area</th> <th>B area</th> </tr> </thead> <tbody> <tr> <td>$\Phi \leq 0.25$</td> <td colspan="2">Ignore</td> </tr> <tr> <td>$0.25 < \Phi \leq 0.50$</td> <td>4</td> <td rowspan="4">Ignore</td> </tr> <tr> <td>$0.50 < \Phi \leq 0.80$</td> <td>1</td> </tr> <tr> <td>$\Phi > 0.80$</td> <td>0</td> </tr> <tr> <td>Total</td> <td>5</td> </tr> </tbody> </table>		Dimension (diameter : Φ)	Acceptance (Q'ty)		A area	B area	$\Phi \leq 0.25$	Ignore		$0.25 < \Phi \leq 0.50$	4	Ignore	$0.50 < \Phi \leq 0.80$	1	$\Phi > 0.80$	0	Total	5	Minor																																		
Dimension (diameter : Φ)	Acceptance (Q'ty)																																																							
	A area	B area																																																						
$\Phi \leq 0.25$	Ignore																																																							
$0.25 < \Phi \leq 0.50$	4	Ignore																																																						
$0.50 < \Phi \leq 0.80$	1																																																							
$\Phi > 0.80$	0																																																							
Total	5																																																							

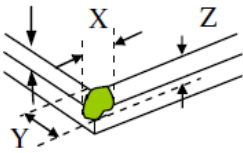
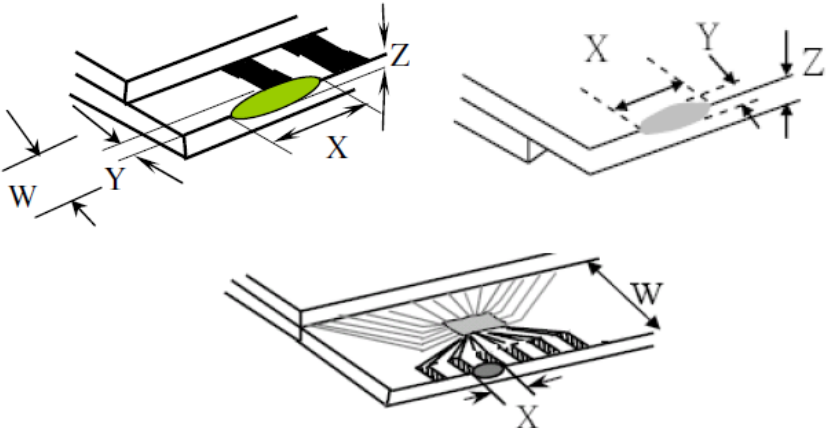
NO	Item	Criterion	Level						
08	The crack of glass	<p>Symbols :</p> <p>X : The length of crack Z : The thickness of crack t : The thickness of glass</p> <p>Y : The width of crack. W : terminal length a : LCD side length</p>	Minor						
		<p>8.1 General glass chip :</p> <p>8.1.1 Chip on panel surface and crack between panels:</p> <div style="text-align: center;">  </div> <table border="1" data-bbox="547 1552 1345 1839" style="margin-left: auto; margin-right: auto;"> <thead> <tr> <th>X</th> <th>Y</th> <th>Z</th> </tr> </thead> <tbody> <tr> <td>$\leq a$</td> <td>Crack can't enter viewing area</td> <td>$\leq 1/2 t$</td> </tr> <tr> <td>$\leq a$</td> <td>Crack can't exceed the half of SP width.</td> <td>$1/2 t < Z \leq 2 t$</td> </tr> </tbody> </table>		X	Y	Z	$\leq a$	Crack can't enter viewing area	$\leq 1/2 t$
X	Y	Z							
$\leq a$	Crack can't enter viewing area	$\leq 1/2 t$							
$\leq a$	Crack can't exceed the half of SP width.	$1/2 t < Z \leq 2 t$							

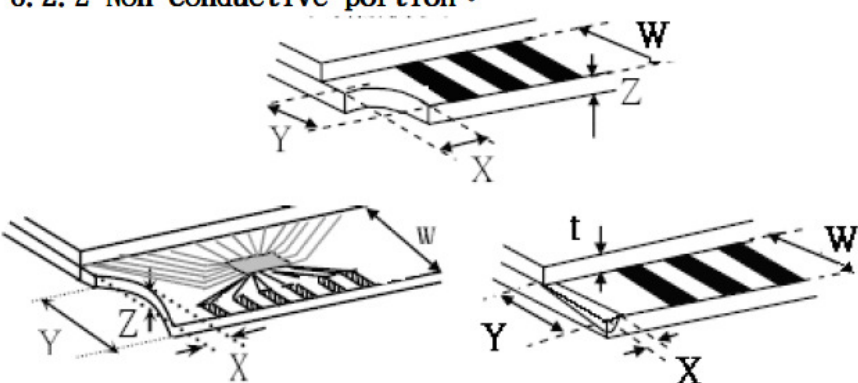
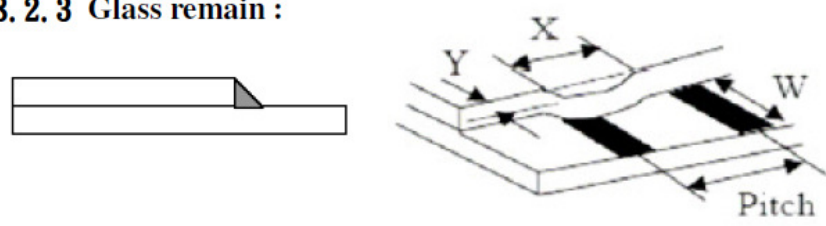
NO	Item	Criterion	Level												
08	The crack of glass	<p>Symbols :</p> <p>X : The length of crack Z : The thickness of crack t : The thickness of glass</p> <p>Y : The width of crack. W : terminal length a : LCD side length</p> <hr/> <p>8.1.2 Corner crack :</p>  <table border="1" data-bbox="526 757 1332 1048"> <thead> <tr> <th>X</th> <th>Y</th> <th>Z</th> </tr> </thead> <tbody> <tr> <td>$\leq 1/5 a$</td> <td>Crack can't enter viewing area</td> <td>$Z \leq 1/2 t$</td> </tr> <tr> <td>$\leq 1/5 a$</td> <td>Crack can't exceed the half of SP width.</td> <td>$1/2 t < Z \leq 2 t$</td> </tr> </tbody> </table>	X	Y	Z	$\leq 1/5 a$	Crack can't enter viewing area	$Z \leq 1/2 t$	$\leq 1/5 a$	Crack can't exceed the half of SP width.	$1/2 t < Z \leq 2 t$				
		X	Y	Z											
$\leq 1/5 a$	Crack can't enter viewing area	$Z \leq 1/2 t$													
$\leq 1/5 a$	Crack can't exceed the half of SP width.	$1/2 t < Z \leq 2 t$													
		<p>8.2 Protrusion over terminal :</p> <p>8.2.1 Chip on electrode pad :</p>  <table border="1" data-bbox="566 1675 1340 1848"> <thead> <tr> <th></th> <th>X</th> <th>Y</th> <th>Z</th> </tr> </thead> <tbody> <tr> <td>Front</td> <td>$\leq a$</td> <td>$\leq 1/2 W$</td> <td>$\leq t$</td> </tr> <tr> <td>Back</td> <td>$\leq a$</td> <td>$\leq W$</td> <td>$\leq 1/2 t$</td> </tr> </tbody> </table>		X	Y	Z	Front	$\leq a$	$\leq 1/2 W$	$\leq t$	Back	$\leq a$	$\leq W$	$\leq 1/2 t$	Minor
	X	Y	Z												
Front	$\leq a$	$\leq 1/2 W$	$\leq t$												
Back	$\leq a$	$\leq W$	$\leq 1/2 t$												

NO	Item	Criterion	Level												
08	The crack of glass	<p>Symbols :</p> <p>X : The length of crack Y : The width of crack. Z : The thickness of crack W : terminal length t : The thickness of glass a : LCD side length</p> <hr/> <p>8.2.2 Non-conductive portion :</p>  <table border="1" data-bbox="638 952 1268 1086" style="margin-left: auto; margin-right: auto;"> <thead> <tr> <th style="text-align: center;">X</th> <th style="text-align: center;">Y</th> <th style="text-align: center;">Z</th> </tr> </thead> <tbody> <tr> <td style="text-align: center;">$\leq 1/3 a$</td> <td style="text-align: center;">$\leq W$</td> <td style="text-align: center;">$\leq t$</td> </tr> </tbody> </table> <p>⊙ If the chipped area touches the ITO terminal, over 2/3 of the ITO must remain and be inspected according to electrode terminal specifications.</p> <p>8.2.3 Glass remain :</p>  <table border="1" data-bbox="558 1512 1252 1624" style="margin-left: auto; margin-right: auto;"> <thead> <tr> <th style="text-align: center;">X</th> <th style="text-align: center;">Y</th> <th style="text-align: center;">Z</th> </tr> </thead> <tbody> <tr> <td style="text-align: center;">$\leq a$</td> <td style="text-align: center;">$\leq 1/3 W$</td> <td style="text-align: center;">$\leq t$</td> </tr> </tbody> </table> <p>8.2.4 Cracking</p>  <p style="text-align: center;">Not Allowed</p>	X	Y	Z	$\leq 1/3 a$	$\leq W$	$\leq t$	X	Y	Z	$\leq a$	$\leq 1/3 W$	$\leq t$	Minor
X	Y	Z													
$\leq 1/3 a$	$\leq W$	$\leq t$													
X	Y	Z													
$\leq a$	$\leq 1/3 W$	$\leq t$													

◆Specification For TFT-LCD Module 3. 5" ~15" :

(Ver.B01)

NO	Item	Criterion	Level
09	Backlight elements	9. 1 Backlight can't work normally.	Major
		9. 2 Backlight doesn't light or color is wrong.	Major
		9. 3 Illumination source flickers when lit.	Major
10	General appearance	10. 1 Pin type 、 quantity 、 dimension must match type in structure diagram.	Major
		10. 2 No short circuits in components on PCB or FPC .	Major
		10. 3 Parts on PCB or FPC must be the same as on the production characteristic chart .There should be no wrong parts , missing parts or excess parts.	Major
		10. 4 Product packaging must the same as specified on packaging specification sheet.	Minor
		10. 5 The folding and peeled off in polarizer are not acceptable.	Minor
		10. 6 The PCB or FPC between B/L assembled distance(PCB or FPC) is ≤ 1.5 mm.	Minor

5. PRECAUTION RELATING PRODUCT HANDLING

5.1 SAFETY

- 5.1.1 If the LCD panel breaks , be careful not to get the liquid crystal to touch your skin.
- 5.1.2 If the liquid crystal touches your skin or clothes , please wash it off immediately by using soap and water.

5.2 HANDLING

- 5.2.1 Avoid any strong mechanical shock which can break the glass.
- 5.2.2 Avoid static electricity which can damage the CMOS LSI—When working with the module , be sure to ground your body and any electrical equipment you may be using.
- 5.2.3 Do not remove the panel or frame from the module.
- 5.2.4 The polarizing plate of the display is very fragile. So , please handle it very carefully ,do not touch , push or rub the exposed polarizing with anything harder than an HB pencil lead (glass , tweezers , etc.)
- 5.2.5 Do not wipe the polarizing plate with a dry cloth , as it may easily scratch the surface of plate.
- 5.2.6 Do not touch the display area with bare hands , this will stain the display area.
- 5.2.7 Do not use ketonics solvent & aromatic solvent. Use with a soft cloth soaked with a cleaning naphtha solvent.
- 5.2.8 To control temperature and time of soldering is $320\pm 10^{\circ}\text{C}$ and 3-5 sec.
- 5.2.9 To avoid liquid (include organic solvent) stained on LCM .

5.3 STORAGE

- 5.3.1 Store the panel or module in a dark place where the temperature is $25^{\circ}\text{C} \pm 5^{\circ}\text{C}$ and the humidity is below 65% RH.
- 5.3.2 Do not place the module near organics solvents or corrosive gases.
- 5.3.3 Do not crush , shake , or jolt the module.

5.4 TERMS OF WARRANTY

- 5.4.1 Applicable warrant period
The period is within thirteen months since the date of shipping out under normal using and storage conditions.
- 5.4.2 Unaccepted responsibility
This product has been manufactured to your company's specification as a part for use in your company's general electronic products. It is guaranteed to perform according to delivery specifications. For any other use apart from general electronic equipment , we cannot take responsibility if the product is used in nuclear power control equipment , aerospace equipment , fire and security systems or any other applications in which there is a direct risk to human life and where extremely high levels of reliability are required.

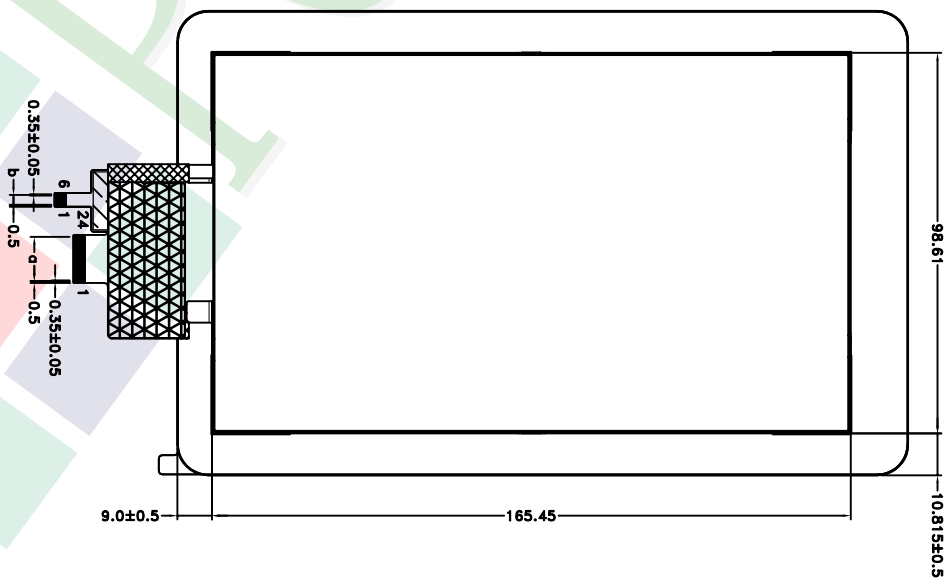
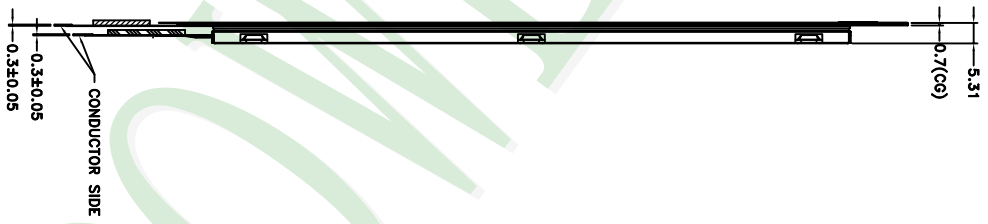
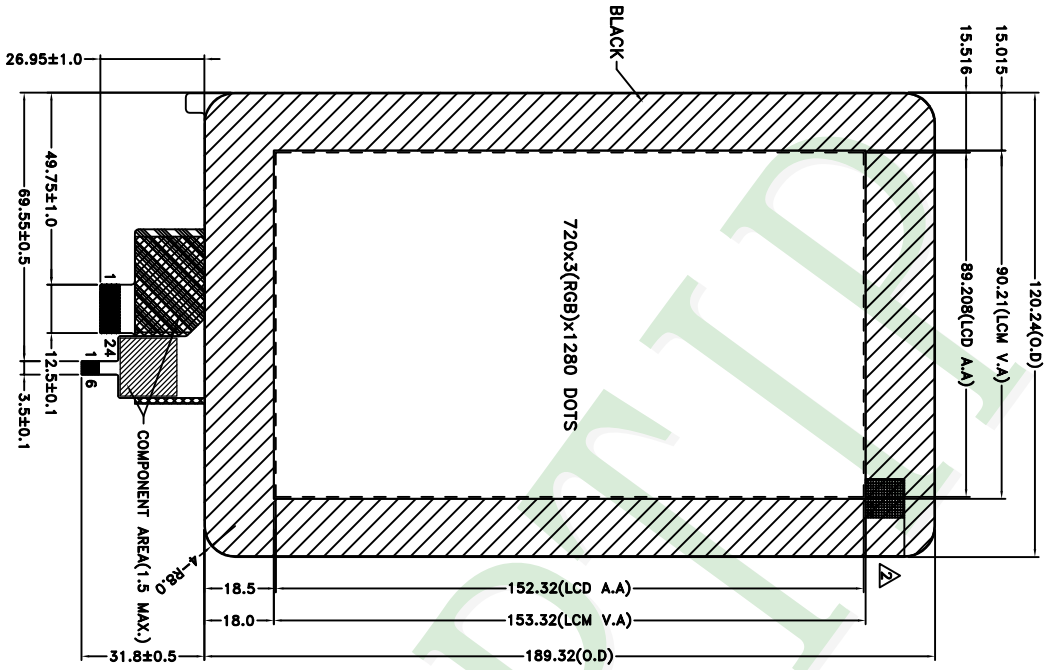

- NOTES:
- 1.LCD TYPE: TFT LCD
 - 2.LCD DISPLAY: Normally Black
 - 3.The tolerance unless classified ±0.3mm
 - 4.I/P suggested connector: "Cullux" GF31061D082-05-NH OR EQUIVALENT
 - 5.I/T suggested connector: "CHIYAO SHUNN" JS-1191DR1-24 OR EQUIVALENT
 - 6.a:PO.5X23=11.5±0.05
 - 7.b:IP0.5X5=2.5±0.05

PART NO: PH720128T003-ZBC02
DRAWING NAME: LMD-PH720128T003-ZBC02

久正光電股份有限公司
POWER TIP TECHNOLOGY CORPORATION

TITLE: LCD MODULE DRAWING

Design	Stone	Surface	
Check	Sam	Material	
Approve	Oliver	Thickness	

007			
006			
005			
004			
003			
002	ADD PULL TAPE	Stone	2018/01/12
001	NEW DRAWING	Stone	2017/06/08
REV	REV BY	REVISER	DATE

1. 包裝材料規格表 (Packaging Material) : (per carton)

No.	Item	Model	Dimensions (mm)	1Pcs Weight	Quantity	Total Weight
1	成品 (LCM)	PH720128T003-ZBC02	120.24 X 189.32	0.178	28	4.984
2	氣泡袋(1)Bubble Bag	BAG200160BRABA	200 X 160	0.0096	28	0.2688
3	A6隔板(2)A6 Partition	BX33800012BZBA	338 X 125 X 3	0.038	16	0.608
4	B6隔板(3)B6 Partition	BX29800012BZBA	298 X 125 X 3	0.023	4	0.092
5	海綿墊(4)Foam Rubber Cushion	OTFOAM00005ABA	330 X 290 X 10	0.025	4	0.1
6	舒美墊(5)EPE	OTFOAMT0006ABA	218 X 125 X 20	0.012	4	0.048
7	C4內盒(6)Product Box	BX36031014AABA	360 X 310 X 142	0.406	2	0.812
8	外紙箱(7)Carton	BX39432432CCBA	394 X 324 X 321	0.884	1	0.884
9						

2. 一整箱總重量 (Total LCD Weight in carton) : 7.8 Kg±10%

3. 單箱數量規格表 (Packaging Specifications and Quantity) :

(1)Quantity Of Spacer : A6隔板 X 8 , B6隔板 X 2

(2)Total LCM quantity in carton : quantity per box 14 x no of boxes 2 = 28

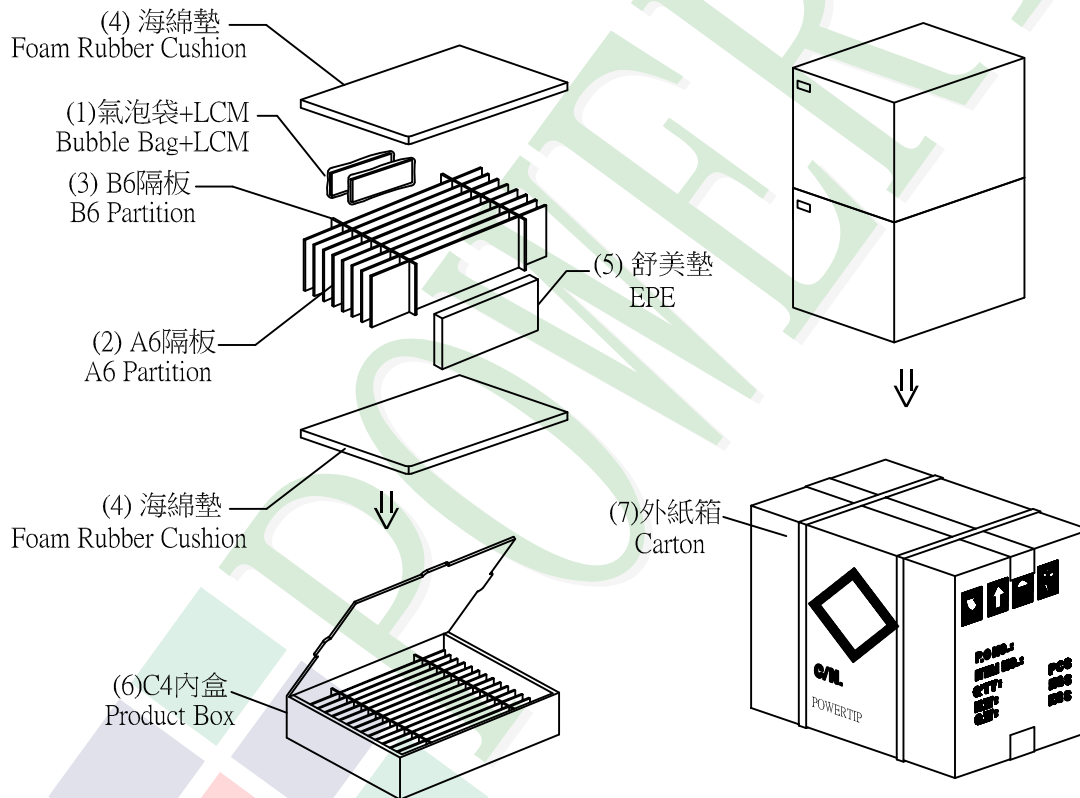

特 記 事 項 (REMARK)

4. 每個間隔放2片模組，前後間隔不放置模組。(如示意圖)

4. 2 LCM are placed on every other slot of the divider.

Note: First and last slot should be empty.

(See remarks 5 on packaging specifications)

5. 放置格示意圖:

5. Each divider is placed inside a product Box

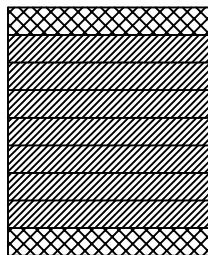

▨ 模組(LCM) X 2pcs.

⊠ 舒美墊(EPE)