



SPECIFICATIONS

CUSTOMER	:	_____
SAMPLE CODE	:	SH480272T015-IAA
MASS PRODUCTION CODE	:	PH480272T015-IAA
SAMPLE VERSION	:	01
SPECIFICATIONS EDITION	:	002
DRAWING NO. (Ver.)	:	LMD-PH480272T015-IAA (Ver.001)
PACKAGING NO. (Ver.)	:	PKG-PH480272T015-IAA (Ver.001)

Customer Approved
Date:

Approved	Checked	Designer
廖志豪 Rex Liao	張慶源 Yuan Chang	陳宗淇 Howard Chen

- Preliminary specification for design input
- Specification for sample approval

POWERTIP TECH. CORP.

Headquarters: No.8, 6 th Road, Taichung Industrial Park, Taichung, Taiwan 台中市 407 工業區六路 8 號	TEL: 886-4-2355-8168 FAX: 886-4-2355-8166	E-mail: sales@powertip.com.tw Http:// www.powertip.com.tw
--	--	--

Contents

1. SPECIFICATIONS

- 1.1 Features
- 1.2 Mechanical Specifications
- 1.3 Absolute Maximum Ratings
- 1.4 DC Electrical Characteristics
- 1.5 Optical Characteristics
- 1.6 Backlight Characteristics

2. MODULE STRUCTURE

- 2.1 Counter Drawing
- 2.2 Interface Pin Description
- 2.3 Timing Characteristics
- 2.4 POWER ON/OFF SEQUENCE

3. QUALITY ASSURANCE SYSTEM

- 3.1 Quality Assurance Flow Chart
- 3.2 Inspection Specification

4. RELIABILITY TEST

- 4.1 Reliability Test Condition

5. PRECAUTION RELATING PRODUCT HANDLING

- 5.1 Safety
- 5.2 Handling
- 5.3 Storage
- 5.4 Terms of Warranty

Appendix : 1.LCM Drawing

2. Packing Specification

Note: For detailed information please refer to IC data sheet: Sitronix --- ST7282-G4-1L-1

1.1 Features

Item	Standard Value
Display Type	480 * 3 (RGB) * 272 Dots
LCD Type	Normally white TN , Transmissive Type
Screen size(inch)	4.3"(Diagonal)
Viewing Direction	6 O'clock (Gray scale Inversion) *1
	12 O'clock (*2)
Color configuration	R,G, B vertical stripe
Backlight	White LED B/L
Display Interface	Digital 24-bits RGB
Driver IC	ST7282-G4-1L-1
ROHS	THIS PRODUCT CONFORMS THE ROHS OF PTC Detail information please refer website : http://www.powertip.com.tw/news_detail.php?Key=1&cID=1

*1. For saturated color display content (eg. pure-red, pure-green, pure-blue or pure-colors -combinations).

*2. "For display content based upon multicolor images eg. photos, RGB defined user interfaces"

1.2 Mechanical Specifications

Item	Standard Value	Unit
Outline Dimension	105.5(W) x 67.2 (L) x 2.9(H)	mm

LCD panel

Item	Standard Value	Unit
Viewing Area	96.04 (W) * 54.856 (L)	mm
Active Area	95.04 (W) x 53.856 (L)	mm
Pixel Size	0.198 (W) * 0.198 (H)	mm

Note : For detailed information please refer to LCM drawing

1.3 Absolute Maximum Ratings

Module

Item	Symbol	Condition	Min.	Max.	Unit
System Power Supply Voltage	VDD	GND=0	-0.5	+4.6	V
Input Voltage Range	V _{in}	-	-0.5	VDD+0.3	V
Operating Temperature	T _{OP}	-	-20	+70	°C
Storage Temperature	T _{ST}	-	-30	+80	°C
Storage Humidity	H _D	T _a ≤ 60 °C	10	90	%RH

1.4 DC Electrical Characteristics

Module

GND = 0V, T_a = 25 °C

Item	Symbol	Condition	Min.	Typ.	Max.	Unit
Power supply Voltage	VDD	-	3.0	3.3	3.6	V
“H” Input Voltage	V _{IH}	-	0.7*VDD	-	VDD	V
“L” Input Voltage	V _{IL}	-	GND	-	0.3* GND	V
“H” Output Voltage	V _{OH}	-	VDD-0.4	-	VDD	V
“L” Output Voltage	V _{OL}	-	GND	-	GND +0.4	V
Supply Current	IDD	VDD=3.3V Pattern= R,G,B *1	-	35	50	mA

Note1: Maximum current display.

1.5 Optical Characteristics

TFT LCD Panel

VDD =3.3V, Ta=25°C

Item	Symbol	Condition	Min.	Typ.	Max.	unit	
Response time	Tr + Tf	Ta = 25°C θX, θY = 0°	-	29	44	ms	Note2
Viewing angle	Top	θY+	-	60	-	Deg.	Note4
	Bottom	θY-	-	60	-		
	Left	θX-	-	60	-		
	Right	θX+	-	60	-		
Contrast ratio	CR		500	600	-	-	-
Color of CIE Coordinate (With B/L)	White	X	0.23	0.28	0.33	-	Note1
		Y	0.25	0.30	0.35		
	Red	X	0.53	0.58	0.63		
		Y	0.31	0.36	0.41		
	Green	X	0.27	0.32	0.37		
		Y	0.52	0.57	0.62		
	Blue	X	0.09	0.14	0.19		
		Y	0.00	0.05	0.10		
Average Brightness Pattern=white display (With B/L) *1	IV	IF= 20 mA	300	330	-	cd/m ²	Note1
Uniformity (With B/L) *2	△B	IF= 20mA	70	-	-	%	Note1

Note1:

1 : $\Delta B = B(\min) / B(\max) \times 100\%$

2 : Measurement Condition for Optical Characteristics:

a : Environment: 25°C ±5°C / 60±20%R.H , no wind , dark room below 10 Lux at typical lamp current and typical operating frequency.

b : Measurement Distance: 500 ± 50 mm , (θ= 0°)

c : Equipment: TOPCON BM-7 fast , (field 1°) , after 10 minutes operation.

d : The uncertainty of the C.I.E coordinate measurement ±0.01 , Average Brightness ± 4%

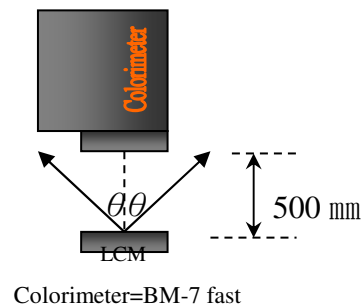
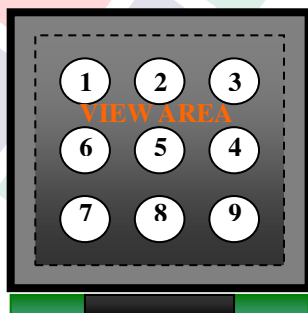

Note2: Definition of response time:

The output signals of photo detector are measured when the input signals are changed from “black” to “white”(falling time) and from “white” to “black”(rising time), respectively. The response time is defined as the time interval between the 10% and 90% of Amplitudes.

Refer to figure as below:

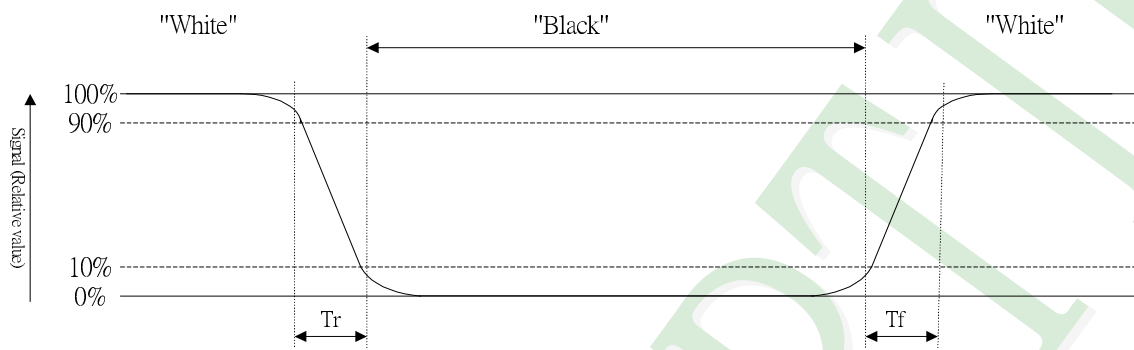

Note3: Definition of contrast ratio:

Contrast ratio is calculated with the following formula

$$\text{Contrast ratio (CR)} = \frac{\text{Photo detector output when LCD is at "White" state}}{\text{Photo detector output when LCD is at "Black" state}}$$

Note4: Definition of viewing angle:

Refer to figure as below:

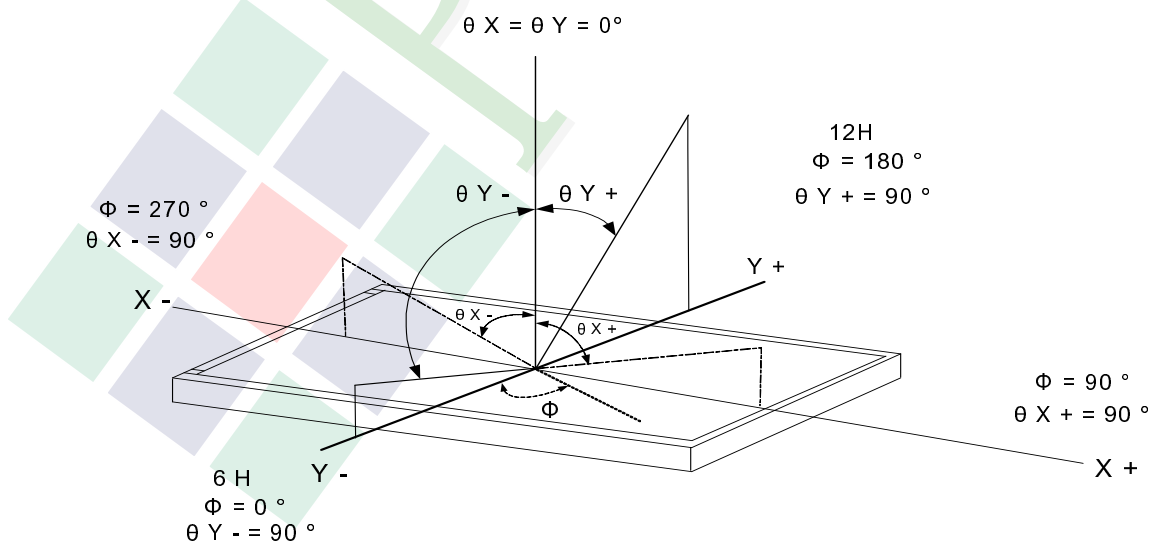

1.6 Backlight Characteristics

Maximum Ratings

Item	Symbol	Conditions	Min.	Max.	Unit
LED Forward Current	IF	Ta =25°C	-	25	mA
LED Reverse Voltage (Each one)	VR	Ta =25°C	-	35	V
Power Dissipation	PD	Ta =25°C	-	595	mW

Electrical / Optical Characteristics

Item	Symbol	Conditions	Min.	Typ.	Max.	Unit
Forward Voltage	VF	IF=20mA	19.6	22.4	24.5	V
Average Brightness (Without LCD)	IV		5500	6000	-	cd/m ²
CIE Color Coordinate (Without LCD)	X		-	0.27	-	-
	Y		-	0.27	-	
Color	White					

*1 : The “LED life time” is defined as the module brightness decrease to 50% original brightness at Ta=25°C and IL=20mA. The LED lifetime could be decreased if operating IL is larger than 20 mA.

Internal Circuit Diagram

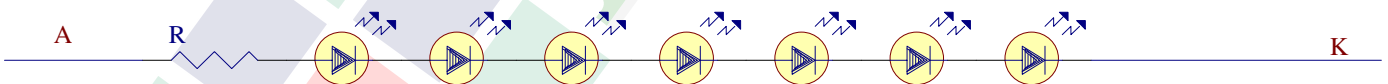

Other Description

Item	Conditions	Description
Life Time*1	Ta =25°C IF= 20mA	20,000 hrs

2. MODULE STRUCTURE

2.1 Counter Drawing

2.1.1 LCM Mechanical Diagram

* See Appendix

2.1.2 Block Diagram

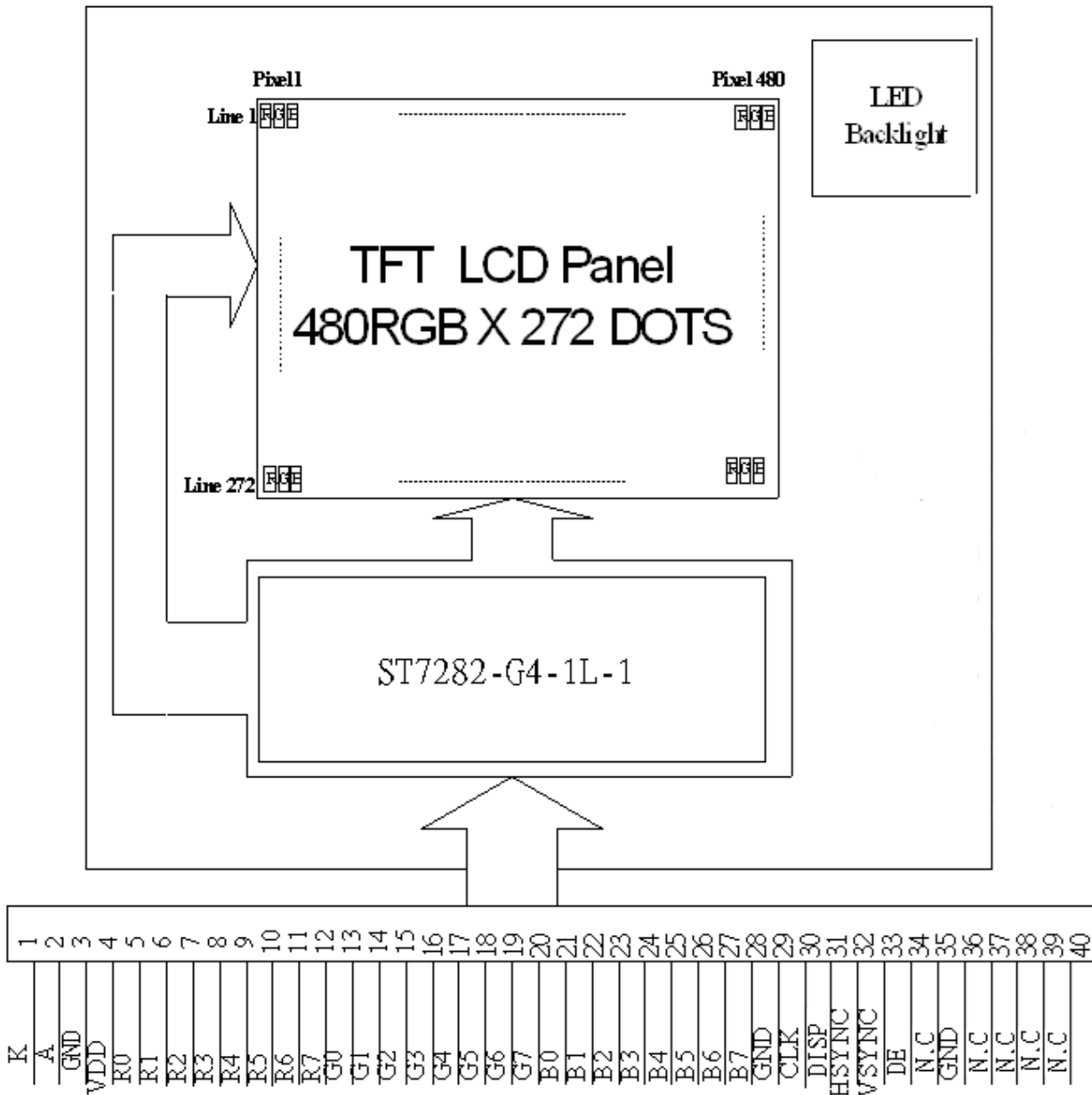

2.2 Interface Pin Description

Pin No.	Symbol	Function
1	K	Power supply for LED Backlight cathode input
2	A	Power supply for LED Backlight anode input
3	GND	Ground
4	VDD	Digital power
5	R0	Red data bit 0
6	R1	Red data bit 1
7	R2	Red data bit 2
8	R3	Red data bit 3
9	R4	Red data bit 4
10	R5	Red data bit 5
11	R6	Red data bit 6
12	R7	Red data bit 7
13	G0	Green data bit 0
14	G1	Green data bit 1
15	G2	Green data bit 2
16	G3	Green data bit 3
17	G4	Green data bit 4
18	G5	Green data bit 5
19	G6	Green data bit 6
20	G7	Green data bit 7

Pin No.	Symbol	Function
21	B0	Blue data bit 0
22	B1	Blue data bit 1
23	B2	Blue data bit 2
24	B3	Blue data bit 3
25	B4	Blue data bit 4
26	B5	Blue data bit 5
27	B6	Blue data bit 6
28	B7	Blue data bit 7
29	GND	Ground
30	CLK	Dot data clock
31	DISP	Display control / standby mode selection "High" : Normal display
32	HSYNC	Horizontal sync input
33	VSYNC	Vertical sync input
34	DE	Data input enable. Active High to enable the data input
35	N.C	Not Connect
36	GND	Ground
37	XR	Not Connect
38	YB	Not Connect
39	XL	Not Connect
40	YT	Not Connect

2.3 Timing Characteristics

2.3.1 Clock and Data Input Timing Diagram

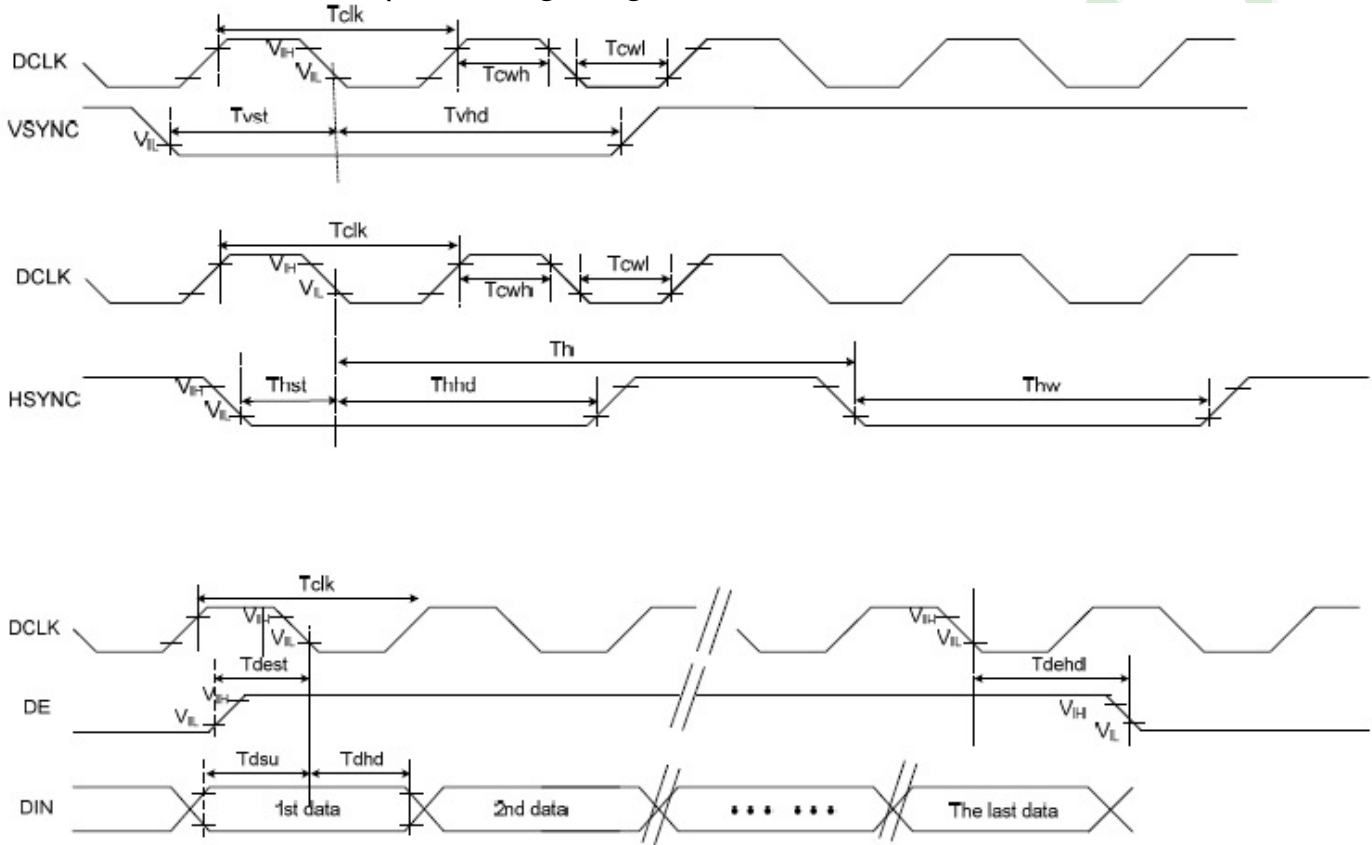

Parameters	Symbol	Spec			Unit	Conditions
		Min.	Typ.	Max.		
System operation timing						
VDD power source slew time	TPOR	--	--	20	ms	From 0V to 99% VDD
GRB pulse width	trSTw	10	50	--	us	R=10Kohm, C=1uF
Input/ Output timing						
CLK pulse duty	Tcw	40	50	60	%	
Hsync width	Thw	2			DCLK	
HSYNC period	Th	55	60	65	us	
VSYNC setup time	Tvst	12	--	--	ns	
VSYNC hold time	Tvhd	12	--	--	ns	
HSYNC setup time	Thst	12	--	--	ns	
HSYNC hold time	Thhd	12	--	--	ns	
Data setup time	Tdsu	12	--	--	ns	
Data hold time	Tdhd	12	--	--	ns	
DE setup time	Tdest	10	--	--	ns	
DE hold time	Tdehd	10	--	--	ns	
SD output stable time	Tst	-	-	12	us	Output settled within +20mV Loading = .6.8k+28.2pF
GD output rise and fall time	Tgst	-	-	6	us	Output settled (5%~95%), Loading = 4.7k+29.8pF

2.3.2 SYNC Mode

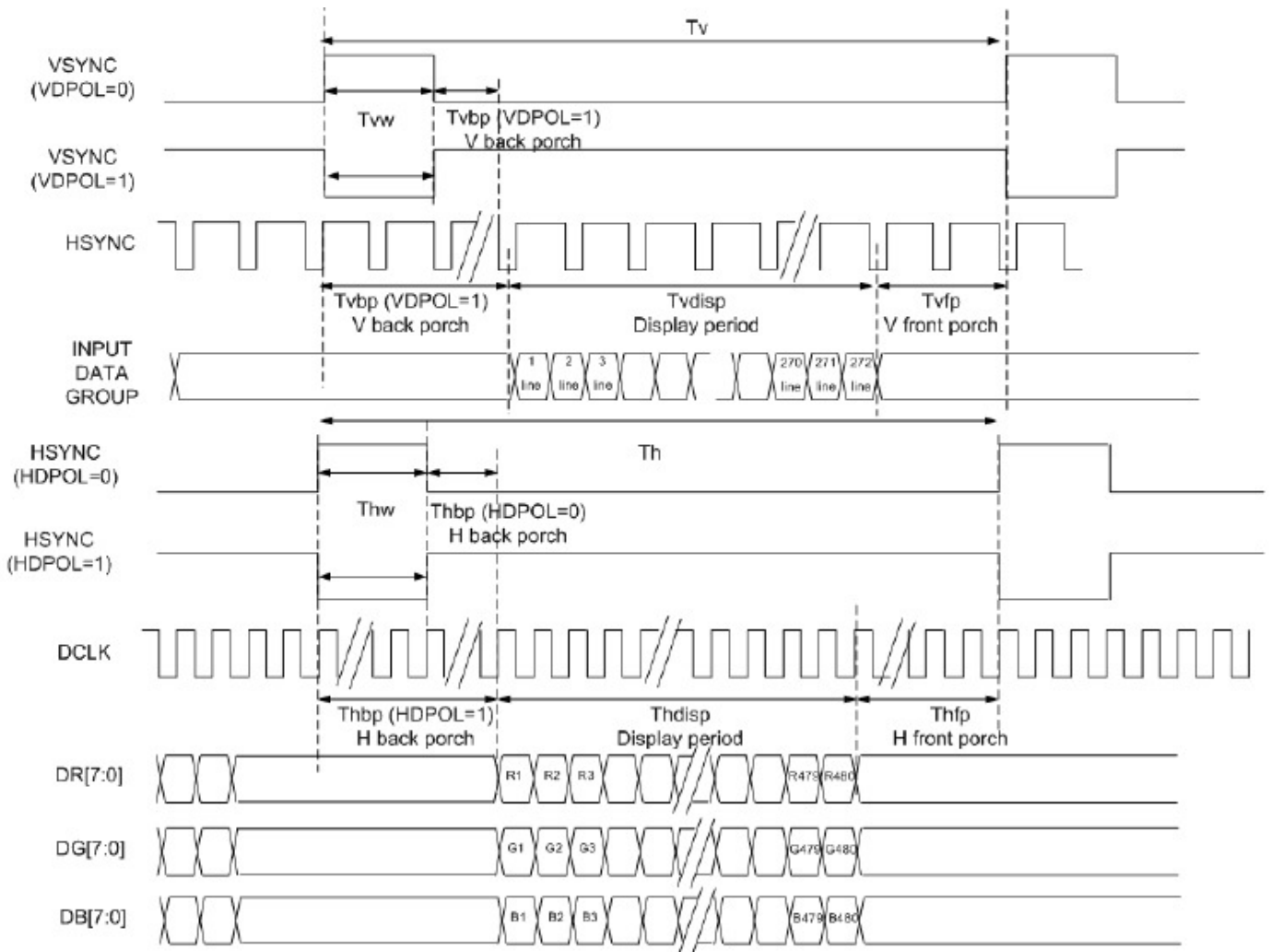

2.3.3 SYNC-DE Mode

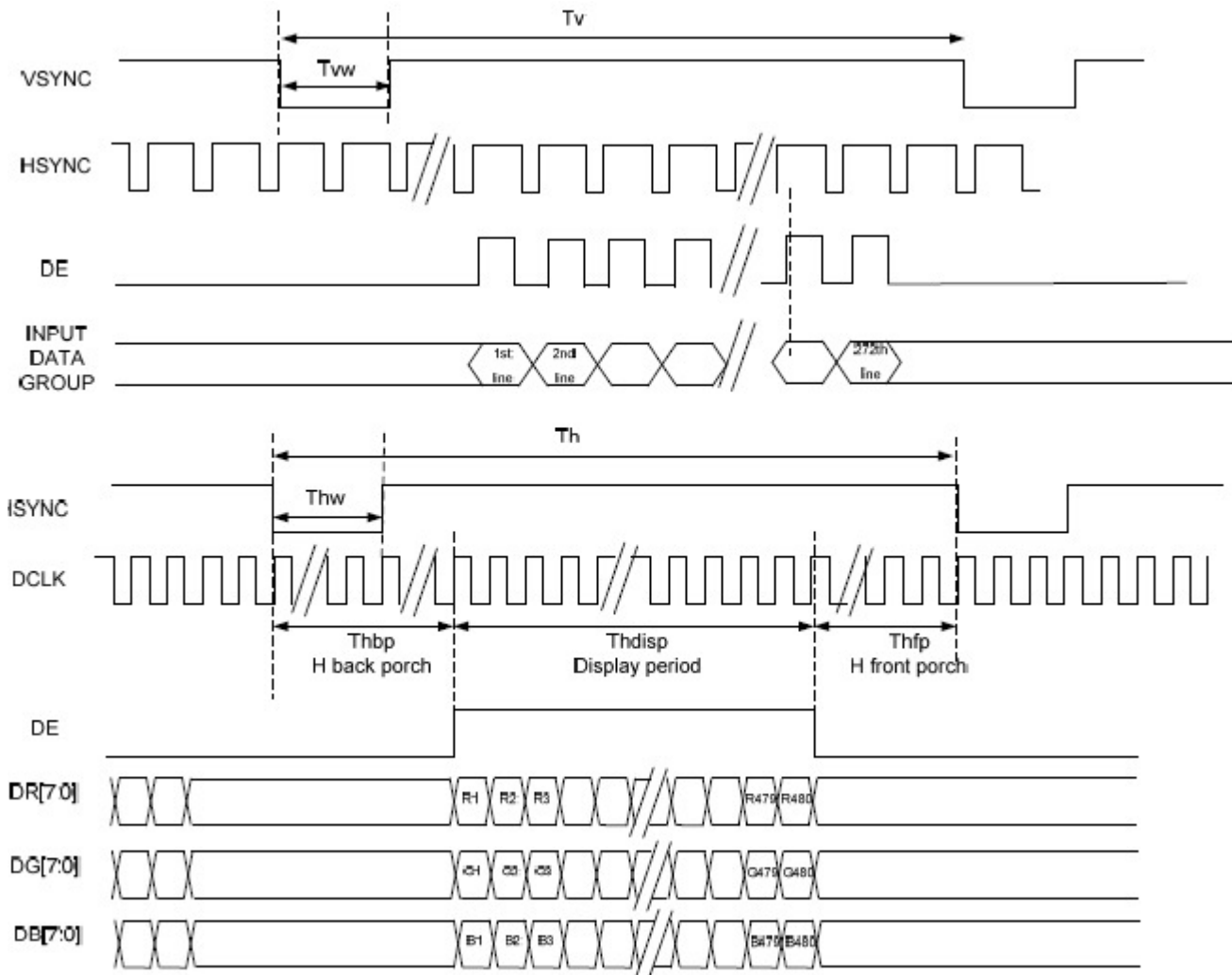

2.3.4 DE Mode

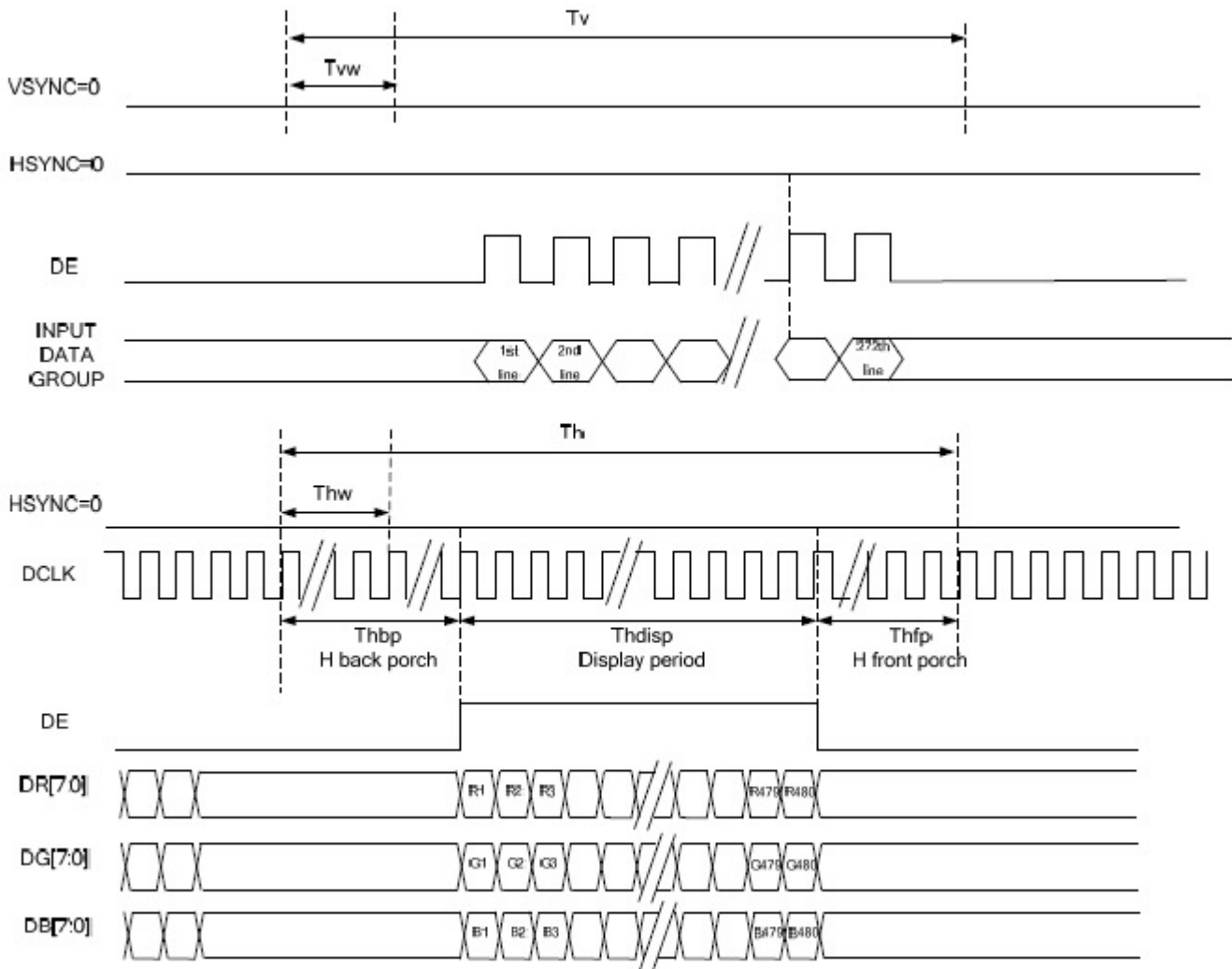

Parallel 24-bit RGB Input Timing Table

Parameters		Symbol	Value			Unit
			Min.	Typ.	Max.	
DCLK frequency		Fclk	8	9	12	MHz
DCLK Period		Tclk	83	111	125	nS
HSYNC	Period Time	Th	485	531	598	DCLK
	Display Period	Thdisp		480		DCLK
	Back Porch	Thbp	3	43	43	DCLK
	Front Porch	Thfp	2	8	75	DCLK
	Pulse Width	Thw	2	4	75	DCLK
VSYNC	Period Time	Tvdisp	276	292	321	H
	Display Period	Tvbp		272		H
	Back Porch	Tvfp	2	12	12	H
	Front Porch	Tvw	2	8	37	H
	Pulse Width	Tvdisp	2	4	37	H

2.4 POWER ON/OFF SEQUENCE

2.4.1 Power On Sequence

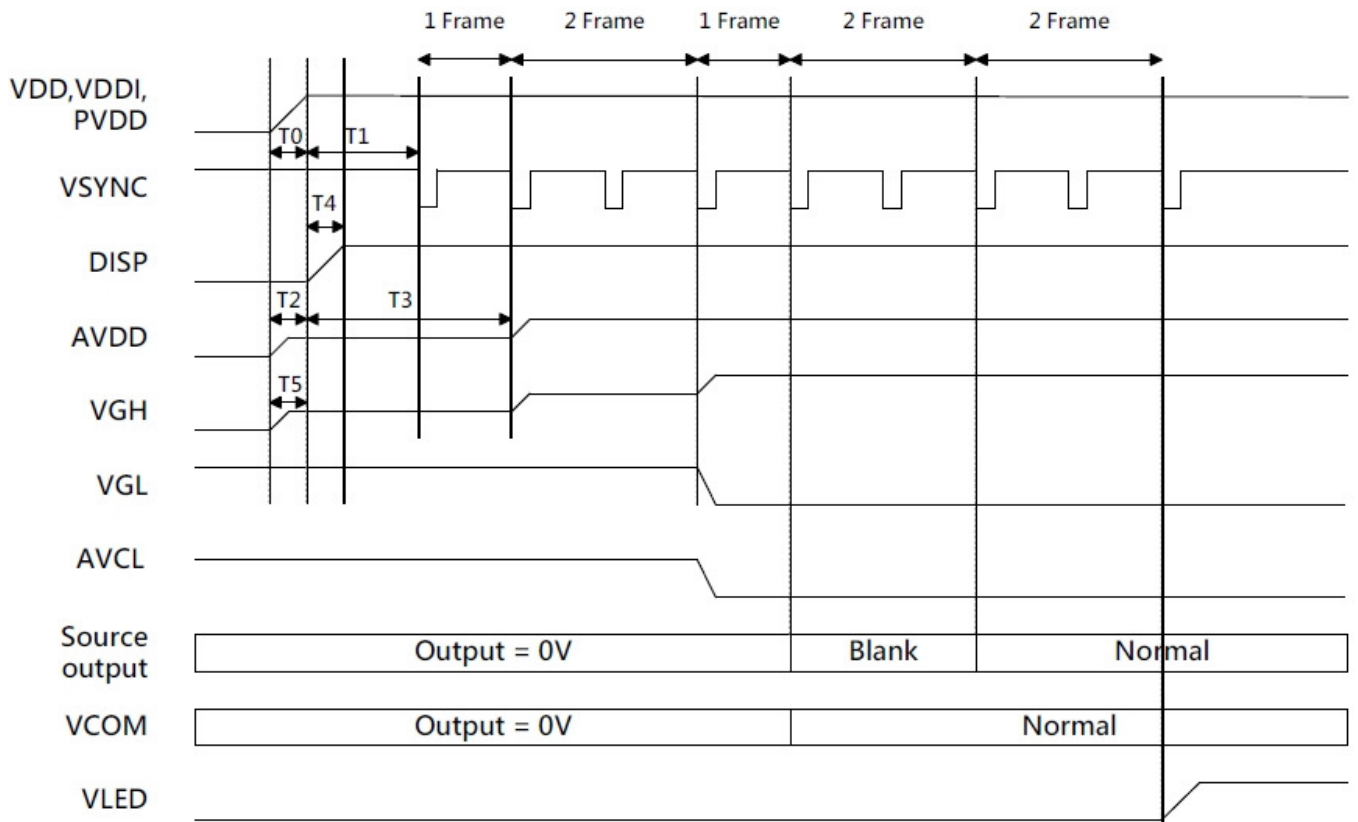

Symbol	Description	Min. Time
T0	Determined by the external power	
T1	Time from stable VDD, VDDI, PVDD set-up to the first VSYNC	T1=0
T2	Time from AVDD=0V to AVDD=3.3V	T2=T0
T3	me from AVDD=3.3V to AVDD=6.0V	T3=T1+ (1*Frame)
T4	Time from stable VDD, VDDI, PVDD set-up to DISP asserted	T4=0
T5	Time from VGH=0V to VGH=3.3V	T5=T0

Note: Recommend the LCM power on rise time T0= 0~ 1ms.

2.4.2 Power Off Sequence

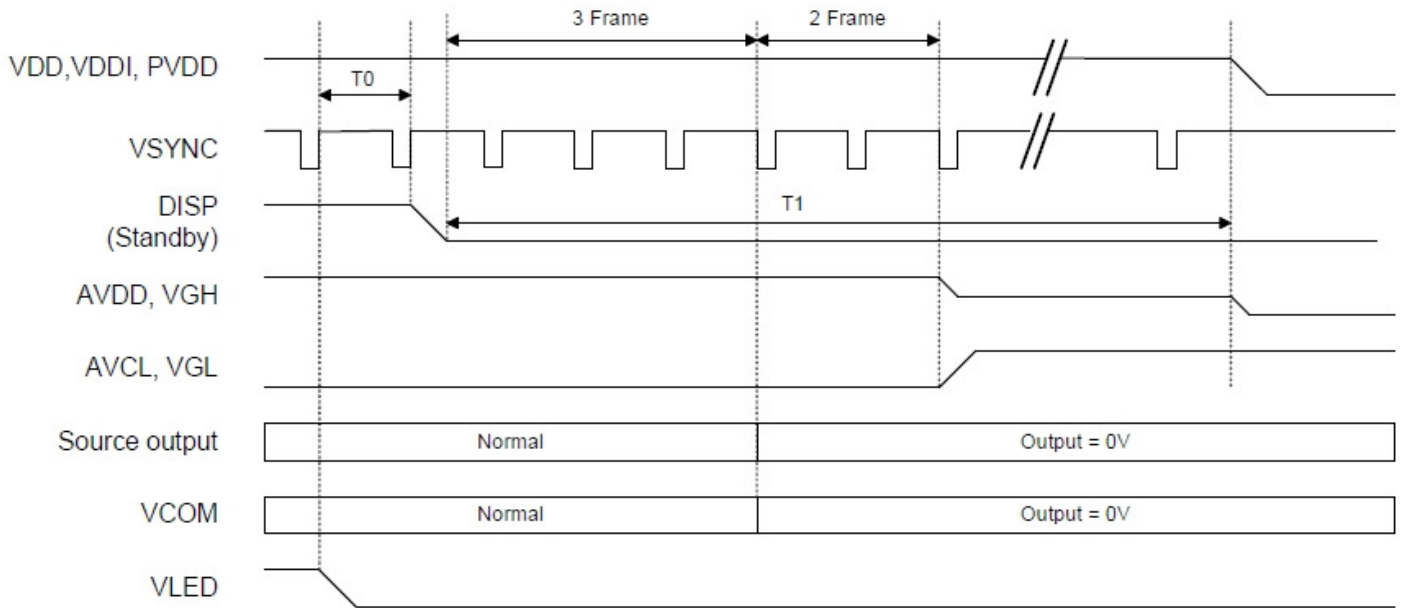

Symbol	Description	Min. Time
T0	Time from backlight power off to DISP="L"	1*Frame
T1	Time from DISP="L" to LCM Power off	5*Frame

3. QUALITY ASSURANCE SYSTEM

3.1 Quality Assurance Flow Chart

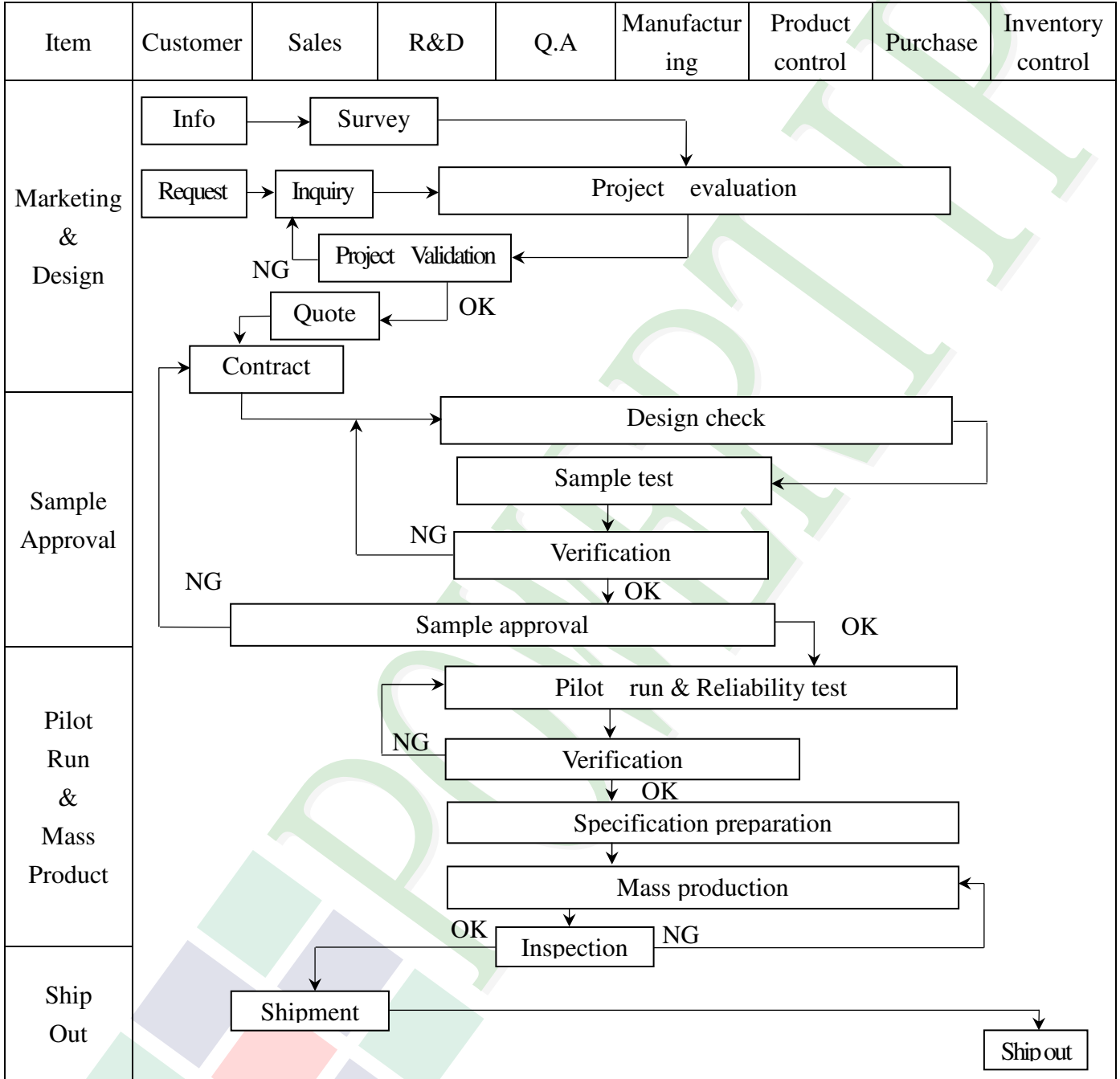

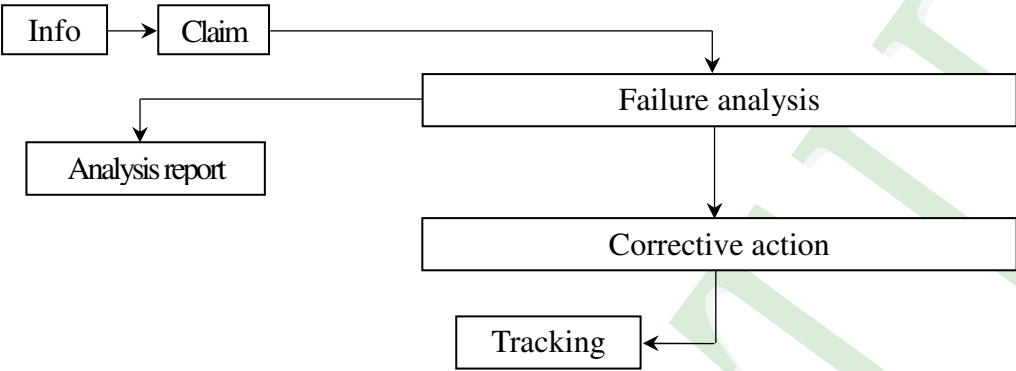
Item	Customer	Sales	R&D	Q.A	Manufacturing	Product control	Purchase	Inventory control
Sales Service	 <pre> graph TD Info[Info] --> Claim[Claim] Claim --> Failure[Failure analysis] Failure --> Report[Analysis report] Failure --> Action[Corrective action] Action --> Tracking[Tracking] </pre>							
Q.A Activity	1. ISO 9001 Maintenance Activities 3. Equipment calibration 5. Standardization Management				2. Process improvement proposal 4. Education And Training Activities			

3.2. Inspection Specification

◆Scope : The document shall be applied to TFT-LCD Module for 3.5" ~15" (Ver.B01).

◆Inspection Standard : MIL-STD-105E Table Normal Inspection Single Sampling Level II.

◆Equipment : Gauge 、 MIL-STD 、 Powertip Tester 、 Sample

◆Defect Level : Major Defect AQL : 0.4 ; Minor Defect AQL : 1.5

◆OUT Going Defect Level : Sampling.

◆Standard of the product appearance test :

a. Manner of appearance test :

(1). The test best be under 20W×2 fluorescent light , and distance of view must be at 30 cm.

(2). The test direction is base on about around 45° of vertical line.

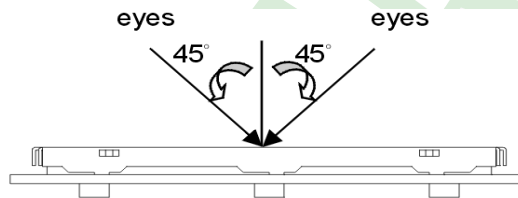

(3). Definition of area.

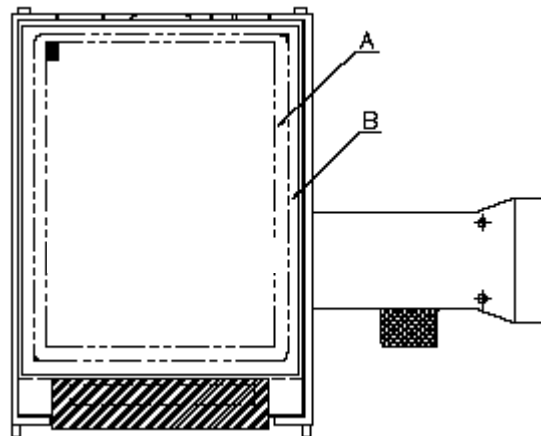

A area : viewing area

B area : Outside of viewing area

(4). Standard of inspection : (Unit : mm)

◆Specification For TFT-LCD Module 3.5" ~15" :

(Ver.B01)

NO	Item	Criterion	Level												
01	Product condition	1. 1The part number is inconsistent with work order of production.	Major												
		1. 2 Mixed product types.	Major												
		1. 3 Assembled in inverse direction.	Major												
02	Quantity	2. 1The quantity is inconsistent with work order of production.	Major												
03	Outline dimension	3. 1 Product dimension and structure must conform to structure diagram.	Major												
04	Electrical Testing	4. 1 Missing line character and icon.	Major												
		4. 2 No function or no display.	Major												
		4. 3 Display malfunction.	Major												
		4. 4 LCD viewing angle defect.	Major												
		4. 5 Current consumption exceeds product specifications.	Major												
		4. 6 Mura can not be seen through 5% ND filter. (Mura : Under the normal examination angle of view,the picture has the non-uniform phenomenon.)	Minor												
05	Dot defect (Bright dot 、 Dark dot) On -display	<table border="1" style="margin-left: auto; margin-right: auto;"> <thead> <tr> <th></th> <th>Item</th> <th>Acceptance (Q'ty)</th> </tr> </thead> <tbody> <tr> <td rowspan="4" style="text-align: center; vertical-align: middle;">Dot Defect</td> <td>Bright Dot</td> <td style="text-align: center;">≤ 4</td> </tr> <tr> <td>Dark Dot</td> <td style="text-align: center;">≤ 5</td> </tr> <tr> <td>Joint Dot</td> <td style="text-align: center;">≤ 3</td> </tr> <tr> <td>Total</td> <td style="text-align: center;">≤ 7</td> </tr> </tbody> </table>		Item	Acceptance (Q'ty)	Dot Defect	Bright Dot	≤ 4	Dark Dot	≤ 5	Joint Dot	≤ 3	Total	≤ 7	Minor
			Item	Acceptance (Q'ty)											
Dot Defect	Bright Dot	≤ 4													
	Dark Dot	≤ 5													
	Joint Dot	≤ 3													
	Total	≤ 7													
<p>5. 1 Inspection pattern : full white , full black , Red , Green and blue screens.</p> <p>5. 2 It is defined as dot defect if defect area $> 1/2$ dot.</p> <p>5. 3 The distance between two dot defect ≥ 5 mm.</p> <p>5. 4 Bright dot that can not be seen through 5% ND filter.</p>															

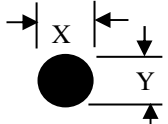
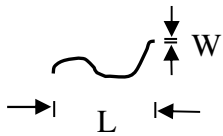
NO	Item	Criterion	Level																																																													
06	<p>Black or white dot、scratch、contamination</p> <p>Round type</p>  <p>$\Phi = (x + y) / 2$</p> <p>Line type</p> 	<p>6.1 Round type (Non-display or display) :</p> <table border="1" data-bbox="512 436 1289 712"> <thead> <tr> <th rowspan="2">Dimension (diameter : Φ)</th> <th colspan="2">Acceptance (Q'ty)</th> </tr> <tr> <th>A area</th> <th>B area</th> </tr> </thead> <tbody> <tr> <td>$\Phi \leq 0.25$</td> <td colspan="2">Ignore</td> </tr> <tr> <td>$0.25 < \Phi \leq 0.50$</td> <td>5</td> <td rowspan="3">Ignore</td> </tr> <tr> <td>$\Phi > 0.50$</td> <td>0</td> </tr> <tr> <td>Total</td> <td>5</td> </tr> </tbody> </table> <p>6.2 Line type(Non-display or display) :</p> <table border="1" data-bbox="434 831 1369 1368"> <thead> <tr> <th rowspan="2">module size</th> <th rowspan="2">Length (L)</th> <th rowspan="2">Width (W)</th> <th colspan="2">Acceptance (Q'ty)</th> </tr> <tr> <th>A area</th> <th>B area</th> </tr> </thead> <tbody> <tr> <td rowspan="4">3.5" to less 9"</td> <td>---</td> <td>$W \leq 0.03$</td> <td colspan="2">Ignore</td> </tr> <tr> <td>$L \leq 10.0$</td> <td>$0.03 < W \leq 0.05$</td> <td>4</td> <td rowspan="3">Ignore</td> </tr> <tr> <td>$L \leq 5.0$</td> <td>$0.05 < W \leq 0.10$</td> <td>2</td> </tr> <tr> <td>---</td> <td>$W > 0.10$</td> <td colspan="2">As round type</td> </tr> <tr> <td colspan="3">Total</td> <td colspan="2">5</td> </tr> <tr> <td rowspan="4">9" to 15"</td> <td>---</td> <td>$W \leq 0.05$</td> <td colspan="2">Ignore</td> </tr> <tr> <td>$L \leq 10.0$</td> <td>$0.05 < W \leq 0.10$</td> <td>5</td> <td rowspan="3">Ignore</td> </tr> <tr> <td>---</td> <td>$W > 0.10$</td> <td colspan="2">As round type</td> </tr> <tr> <td colspan="3">Total</td> <td colspan="2">5</td> </tr> </tbody> </table>	Dimension (diameter : Φ)	Acceptance (Q'ty)		A area	B area	$\Phi \leq 0.25$	Ignore		$0.25 < \Phi \leq 0.50$	5	Ignore	$\Phi > 0.50$	0	Total	5	module size	Length (L)	Width (W)	Acceptance (Q'ty)		A area	B area	3.5" to less 9"	---	$W \leq 0.03$	Ignore		$L \leq 10.0$	$0.03 < W \leq 0.05$	4	Ignore	$L \leq 5.0$	$0.05 < W \leq 0.10$	2	---	$W > 0.10$	As round type		Total			5		9" to 15"	---	$W \leq 0.05$	Ignore		$L \leq 10.0$	$0.05 < W \leq 0.10$	5	Ignore	---	$W > 0.10$	As round type		Total			5		Minor
Dimension (diameter : Φ)	Acceptance (Q'ty)																																																															
	A area	B area																																																														
$\Phi \leq 0.25$	Ignore																																																															
$0.25 < \Phi \leq 0.50$	5	Ignore																																																														
$\Phi > 0.50$	0																																																															
Total	5																																																															
module size	Length (L)	Width (W)	Acceptance (Q'ty)																																																													
			A area	B area																																																												
3.5" to less 9"	---	$W \leq 0.03$	Ignore																																																													
	$L \leq 10.0$	$0.03 < W \leq 0.05$	4	Ignore																																																												
	$L \leq 5.0$	$0.05 < W \leq 0.10$	2																																																													
	---	$W > 0.10$	As round type																																																													
Total			5																																																													
9" to 15"	---	$W \leq 0.05$	Ignore																																																													
	$L \leq 10.0$	$0.05 < W \leq 0.10$	5	Ignore																																																												
	---	$W > 0.10$	As round type																																																													
	Total				5																																																											
07	Polarizer Bubble	<table border="1" data-bbox="478 1512 1326 1933"> <thead> <tr> <th rowspan="2">Dimension (diameter : Φ)</th> <th colspan="2">Acceptance (Q'ty)</th> </tr> <tr> <th>A area</th> <th>B area</th> </tr> </thead> <tbody> <tr> <td>$\Phi \leq 0.25$</td> <td colspan="2">Ignore</td> </tr> <tr> <td>$0.25 < \Phi \leq 0.50$</td> <td>4</td> <td rowspan="3">Ignore</td> </tr> <tr> <td>$0.50 < \Phi \leq 0.80$</td> <td>1</td> </tr> <tr> <td>$\Phi > 0.80$</td> <td>0</td> </tr> <tr> <td>Total</td> <td colspan="2">5</td> </tr> </tbody> </table>	Dimension (diameter : Φ)	Acceptance (Q'ty)		A area	B area	$\Phi \leq 0.25$	Ignore		$0.25 < \Phi \leq 0.50$	4	Ignore	$0.50 < \Phi \leq 0.80$	1	$\Phi > 0.80$	0	Total	5		Minor																																											
Dimension (diameter : Φ)	Acceptance (Q'ty)																																																															
	A area	B area																																																														
$\Phi \leq 0.25$	Ignore																																																															
$0.25 < \Phi \leq 0.50$	4	Ignore																																																														
$0.50 < \Phi \leq 0.80$	1																																																															
$\Phi > 0.80$	0																																																															
Total	5																																																															

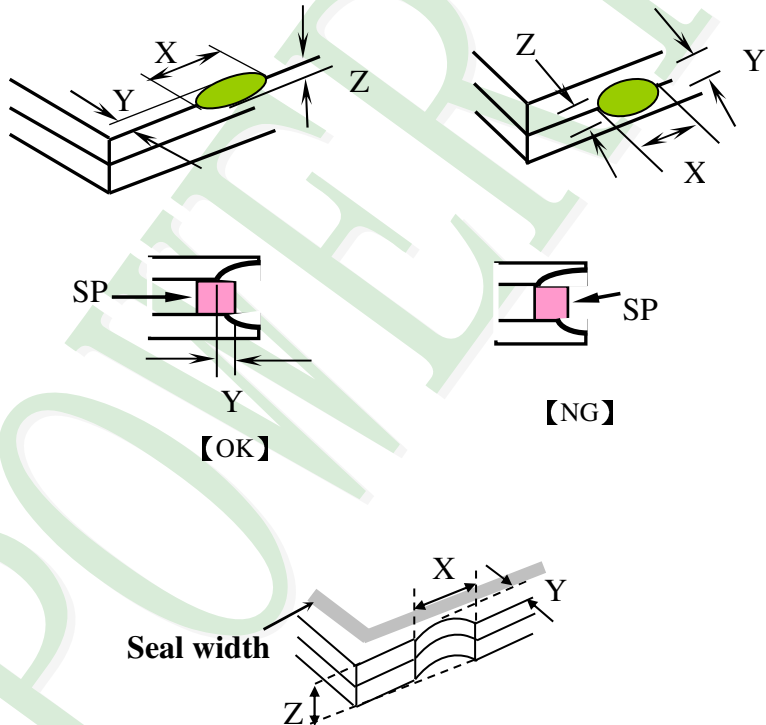
NO	Item	Criterion	Level						
08	The crack of glass	<p>Symbols :</p> <p>X : The length of crack Z : The thickness of crack t : The thickness of glass</p> <p>Y : The width of crack. W : terminal length a : LCD side length</p>	Minor						
		<p>8.1 General glass chip :</p> <p>8.1.1 Chip on panel surface and crack between panels:</p>  <table border="1" data-bbox="539 1585 1353 1881"> <thead> <tr> <th>X</th> <th>Y</th> <th>Z</th> </tr> </thead> <tbody> <tr> <td>$\leq a$</td> <td>Crack can't enter viewing area</td> <td>$\leq 1/2 t$</td> </tr> <tr> <td>$\leq a$</td> <td>Crack can't exceed the half of SP width.</td> <td>$1/2 t < Z \leq 2 t$</td> </tr> </tbody> </table>		X	Y	Z	$\leq a$	Crack can't enter viewing area	$\leq 1/2 t$
X	Y	Z							
$\leq a$	Crack can't enter viewing area	$\leq 1/2 t$							
$\leq a$	Crack can't exceed the half of SP width.	$1/2 t < Z \leq 2 t$							

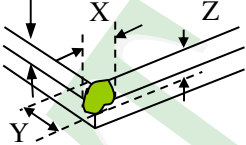
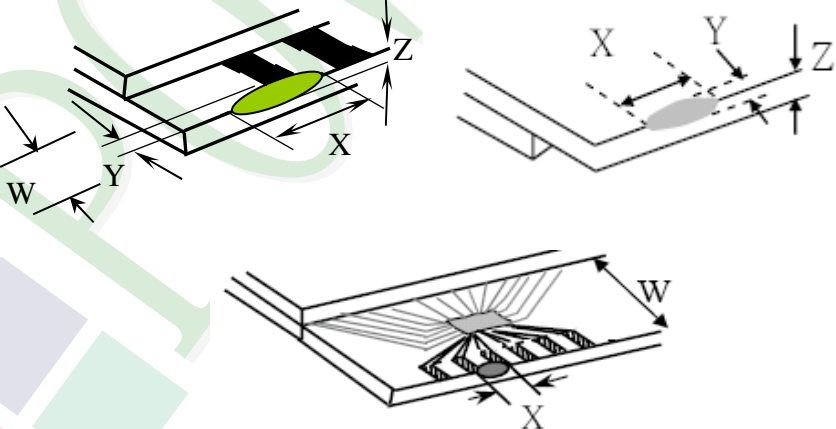
NO	Item	Criterion	Level										
08	The crack of glass	<p>Symbols :</p> <p>X : The length of crack Z : The thickness of crack t : The thickness of glass</p> <p>Y : The width of crack. W : terminal length a : LCD side length</p> <hr/> <p>8.1.2 Corner crack :</p>  <table border="1" data-bbox="520 779 1337 1070"> <thead> <tr> <th>X</th> <th>Y</th> <th>Z</th> </tr> </thead> <tbody> <tr> <td>$\leq 1/5 a$</td> <td>Crack can't enter viewing area</td> <td>$Z \leq 1/2 t$</td> </tr> <tr> <td>$\leq 1/5 a$</td> <td>Crack can't exceed the half of SP width.</td> <td>$1/2 t < Z \leq 2 t$</td> </tr> </tbody> </table>	X	Y	Z	$\leq 1/5 a$	Crack can't enter viewing area	$Z \leq 1/2 t$	$\leq 1/5 a$	Crack can't exceed the half of SP width.	$1/2 t < Z \leq 2 t$		
		X	Y	Z									
$\leq 1/5 a$	Crack can't enter viewing area	$Z \leq 1/2 t$											
$\leq 1/5 a$	Crack can't exceed the half of SP width.	$1/2 t < Z \leq 2 t$											
<p>8.2 Protrusion over terminal :</p> <p>8.2.1 Chip on electrode pad :</p>  <table border="1" data-bbox="558 1711 1347 1886"> <thead> <tr> <th></th> <th>X</th> <th>Y</th> <th>Z</th> </tr> </thead> <tbody> <tr> <td>Front</td> <td>$\leq a$</td> <td>$\leq 1/2 W$</td> <td>$\leq t$</td> </tr> <tr> <td>Back</td> <td>$\leq a$</td> <td>$\leq W$</td> <td>$\leq 1/2 t$</td> </tr> </tbody> </table>		X	Y	Z	Front	$\leq a$	$\leq 1/2 W$	$\leq t$	Back	$\leq a$	$\leq W$	$\leq 1/2 t$	Minor
	X	Y	Z										
Front	$\leq a$	$\leq 1/2 W$	$\leq t$										
Back	$\leq a$	$\leq W$	$\leq 1/2 t$										

◆Specification For TFT-LCD Module 3.5" ~15" :

(Ver.B01)

NO	Item	Criterion	Level
09	Backlight elements	9. 1 Backlight can't work normally.	Major
		9. 2 Backlight doesn't light or color is wrong.	Major
		9. 3 Illumination source flickers when lit.	Major
10	General appearance	10. 1 Pin type 、 quantity 、 dimension must match type in structure diagram.	Major
		10. 2 No short circuits in components on PCB or FPC .	Major
		10. 3 Parts on PCB or FPC must be the same as on the production characteristic chart .There should be no wrong parts , missing parts or excess parts.	Major
		10. 4 Product packaging must the same as specified on packaging specification sheet.	Minor
		10. 5 The folding and peeled off in polarizer are not acceptable.	Minor
		10. 6 The PCB or FPC between B/L assembled distance(PCB or FPC) is ≤ 1.5 mm.	Minor

5. PRECAUTION RELATING PRODUCT HANDLING

5.1 SAFETY

- 5.1.1 If the LCD panel breaks , be careful not to get the liquid crystal to touch your skin.
- 5.1.2 If the liquid crystal touches your skin or clothes , please wash it off immediately by using soap and water.

5.2 HANDLING

- 5.2.1 Avoid any strong mechanical shock which can break the glass.
- 5.2.2 Avoid static electricity which can damage the CMOS LSI—When working with the module , be sure to ground your body and any electrical equipment you may be using.
- 5.2.3 Do not remove the panel or frame from the module.
- 5.2.4 The polarizing plate of the display is very fragile. So , please handle it very carefully, do not touch , push or rub the exposed polarizing with anything harder than an HB pencil lead (glass , tweezers , etc.)
- 5.2.5 Do not wipe the polarizing plate with a dry cloth , as it may easily scratch the surface of plate.
- 5.2.6 Do not touch the display area with bare hands , this will stain the display area.
- 5.2.7 Do not use ketonics solvent & aromatic solvent. Use with a soft cloth soaked with a cleaning naphtha solvent.
- 5.2.8 To control temperature and time of soldering is $320 \pm 10^{\circ}\text{C}$ and 3-5 sec.
- 5.2.9 To avoid liquid (include organic solvent) stained on LCM

5.3 STORAGE

- 5.3.1 Store the panel or module in a dark place where the temperature is $25^{\circ}\text{C} \pm 5^{\circ}\text{C}$ and the humidity is below 65% RH.
- 5.3.2 Do not place the module near organics solvents or corrosive gases.
- 5.3.3 Do not crush , shake , or jolt the module.

5.4 TERMS OF WARRANTY

- 5.4.1 Applicable warrant period
The period is within thirteen months since the date of shipping out under normal using and storage conditions.
- 5.4.2 Unaccepted responsibility
This product has been manufactured to your company's specification as a part for use in your company's general electronic products. It is guaranteed to perform according to delivery specifications. For any other use apart from general electronic equipment, we cannot take responsibility if the product is used in nuclear power control equipment, aerospace equipment , fire and security systems or any other applications in which there is a direct risk to human life and where extremely high levels of reliability are required.

105.5(O.D)	3.35
98.8(Frame V.A)	4.43
97.1(PLZ O.D)	4.96
96.04(LCM V.A)	5.46
95.04(LCD A.A)	

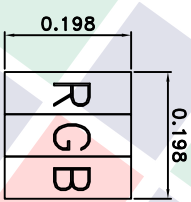
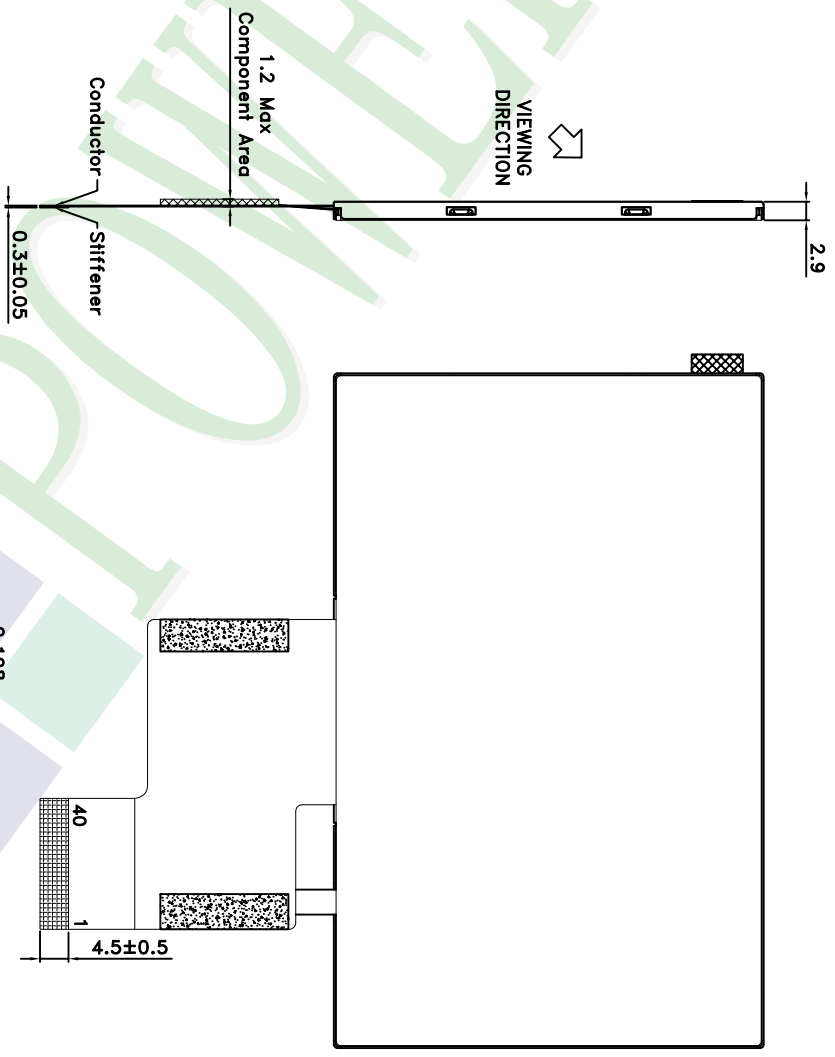
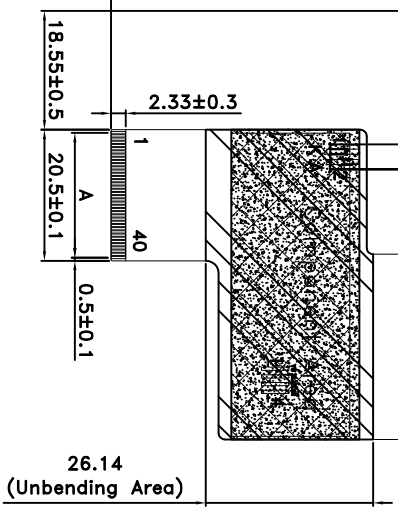
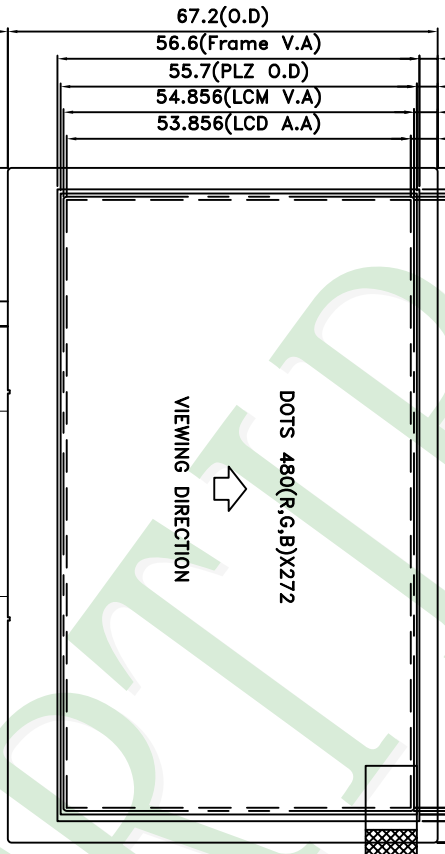

NOTES:
 1. LCD TYPE: TFT
 2. LCD DISPLAY: POSITIVE/TRANSMISSIVE
 3. VIEW DIRECTION: 6 O'CLOCK
 4. The tolerance unless classified ±0.3mm
 5. FPC suggested connector : 08 6262 040 340 846+(KYOCERA) or compatible

6. Shielding tape; Unbending Area
 7. A=0.5X39=19.5±0.05 , W=0.35±0.05

007			
006			
005			
004			
003			
002			
001	NEW DRAWING	Clare	2019/1/17
REV	REV BY	REVISER	DATE

PART NO:	PH480272T015-IAA
DRAWING NAME:	LMD-PH480272T015-IAA
TITLE:	LCD MODULE DRAWING

Design	Clare Chen
Check	Tina Chen
Approve	Jimmy Chen

久正光電股份有限公司
 POWER TIP TECHNOLOGY CORPORATION

Unit	MM	Surface		Precision Level
Scale	FIT	Material		
Page	1/1	Thickness		
Quantity				
		Tolerance (mm)		
		1 ~ 4		
		4 ~ 16		
		16 ~ 63		
		63 ~ 250		
		250 ~ 1000		

Ver.001

Documents NO. PKG-PH480272T015-IAA

LCM包裝規格書

LCM Packaging Specifications

Approve	Check	Contact
Jimmy	Tina	Clare

1. 包裝材料規格表 (Packaging Material) : (per carton)

No.	Item	Model	Dimensions (mm)	1Pcs Weight	Quantity	Total Weight
1	成品 (LCM)	PH480272T015-IAA	105.5 X 67.2	0.0444	160	7.104
2	氣泡袋(1)Bubble Bag	BAG0000000005	150 X 120	0.002	160	0.32
3	A2隔板(2)A2 Partition	BX29300070BMBA	295 X 72 X 2.5	0.0109	88	0.9592
4	B2隔板(3)B2 Partition	BX24500070BLBA	245 X 72 X 2.5	0.0094	24	0.2256
5	氣泡紙(4)Bubble Sheet	BAG280240BWABA	280 X 240	0.006	16	0.096
6	C2內盒(5)Product Box	BX31025580AABA	310 X 255 X 86	0.16	8	1.28
7	外紙箱(6)Carton	BX52732536CCBA	527 X 325 X 360	0.83	1	0.83
8						
9						

2. 一整箱總重量 (Total LCD Weight in carton) : 10.81 Kg±10%

3. 單箱數量規格表 (Packaging Specifications and Quantity) :

(1)Quantity Of Spacer : A2隔板 X 11 , B2隔板 X 3

(2)Total LCM quantity in carton : quantity per box 20 x no of boxes 8 = 160

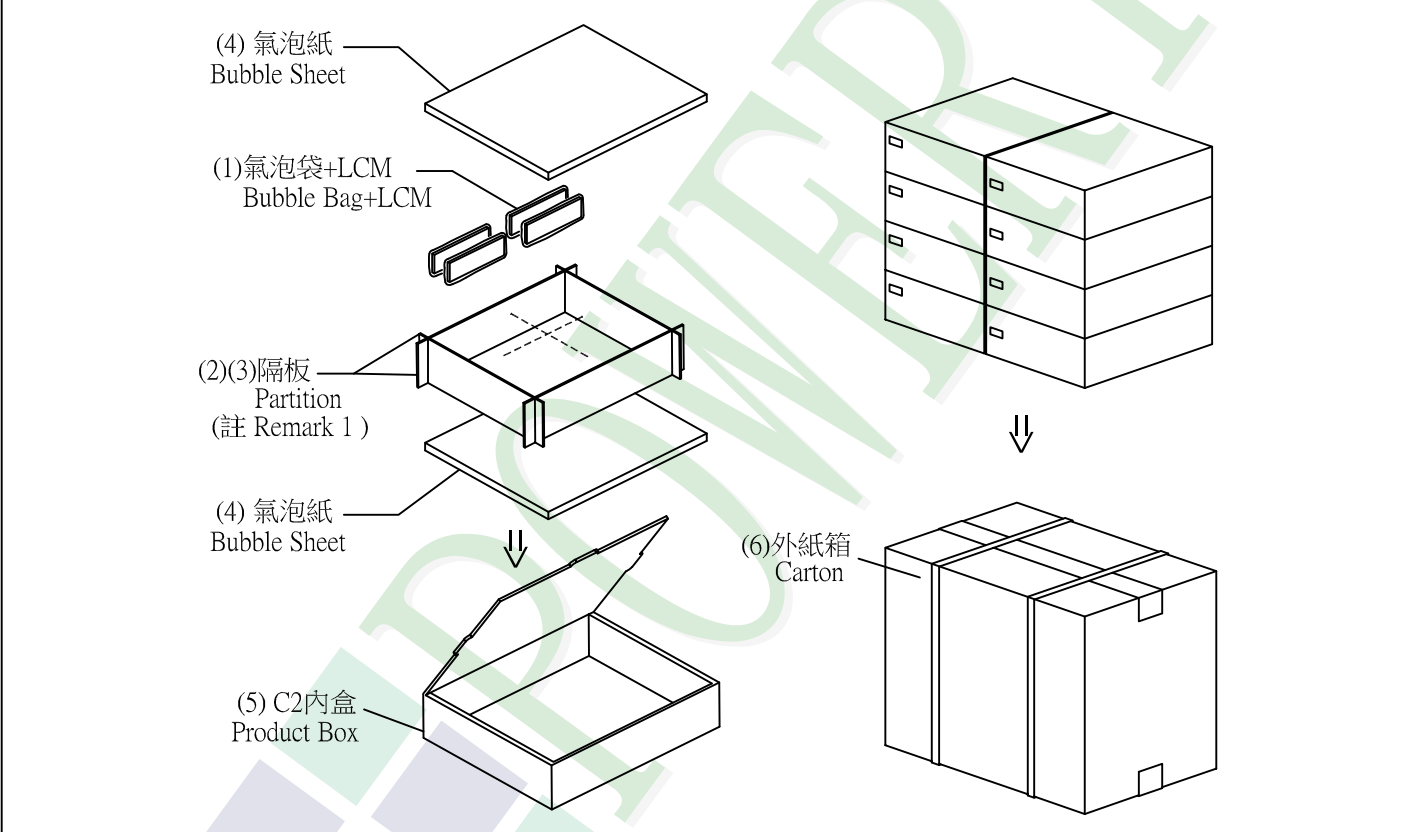

特記事項 (REMARK)

1. LCM排放示意圖(前後間隔不放置):
 1. LCM placed as figure showing:
 (First and last slot should be empty)

▨ 模組(LCM) X 1pcs.

