



SPECIFICATIONS

CUSTOMER	:	CDE012
SAMPLE CODE	:	SH240320T075-ZHA
MASS PRODUCTION CODE	:	PH240320T075-ZHA
SAMPLE VERSION	:	01
SPECIFICATIONS EDITION	:	006
DRAWING NO. (Ver.)	:	LMD-PH240320T075-ZHA (Ver.002)
PACKAGING NO. (Ver.)	:	PKG-PH240320T075-ZHA (Ver.001)

Customer Approved

Date:

Approved	Checked	Designer
廖志豪 Rex Liao	張慶源 Yuan Chang	陳宗淇 Howard Chen

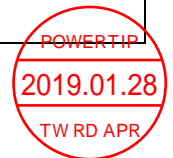

- Preliminary specification for design input
- Specification for sample approval

POWERTIP TECH. CORP.

Headquarters:

No.8, 6th Road, Taichung Industrial Park,
Taichung, Taiwan
台中市 407 工業區六路 8 號

TEL: 886-4-2355-8168
FAX: 886-4-2355-8166

E-mail: sales@powertip.com.tw
[Http://www.powertip.com.tw](http://www.powertip.com.tw)

Contents

1. SPECIFICATIONS

- 1.1 Features
- 1.2 Mechanical Specifications
- 1.3 Absolute Maximum Ratings
- 1.4 DC Electrical Characteristics
- 1.5 Optical Characteristics
- 1.6 Backlight Characteristics

2. MODULE STRUCTURE

- 2.1 Counter Drawing
- 2.2 Interface Pin Description
- 2.3 Timing Characteristics

3. QUALITY ASSURANCE SYSTEM

- 3.1 Quality Assurance Flow Chart
- 3.2 Inspection Specification

4. RELIABILITY TEST

- 4.1 Reliability Test Condition

5. PRECAUTION RELATING PRODUCT HANDLING

- 5.1 Safety
- 5.2 Handling
- 5.3 Storage
- 5.4 Terms of Warranty

Appendix : 1.LCM Drawing

2. Packing Specification

Note : For detailed information please refer to IC data sheet :

Primacy(TFT LCD): Sitnox ST7789VI(Or Compatible IC)

1. SPECIFICATIONS

1.1 Features

Item	Standard Value
Display Type	240 * 3 (RGB) * 320 Dots
LCD Type	Full Viewing Angle , Normally Black , Transmissive type
Screen size(inch)	2.8 inch
Color configuration	RGB-Strip
Backlight Type	White LED B/L
Interface	18/16/9/8-bits 8080 Interface
Other(controller/driver IC)	ST7789VI (Or Compatible IC)
ROHS	THIS PRODUCT CONFORMS THE ROHS OF PTC Detail information please refer website : http://www.powertip.com.tw/news_detail.php?Key=1&cID=1

Note:

1.2 Mechanical Specifications

Item	Standard Value	Unit
Outline Dimension	50.0(W) *70.0 (L) *2.8(H)	mm

LCD Panel

Item	Standard Value	Unit
Active Area	43.2(W) *57.6 (L)	mm
Pixel Size	0.18(W) *0.18 (H)	mm

Note : For detailed information please refer to LCM drawing

1.3 Absolute Maximum Ratings

Module

Item	Symbol	Condition	Min.	Max.	Unit
System Power Supply Voltage	VCC	GND=0	-0.3	4.6	V
	IOCC	GND=0	-0.3	4.6	V
Operating Temperature	T _{OP}	-	-20	70	°C
Storage Temperature	T _{ST}	-	-30	80	°C
Storage Humidity	H _D	T _a ≤ 60 °C	10	90	%RH

1.4 DC Electrical Characteristics

Module

GND = 0V, T_a = 25 °C

Item	Symbol	Condition	Min.	Typ.	Max.	Unit
Power Supply Voltage	VCC	-	-	2.8	-	V
	IOVCC	-	-	2.8	-	V
Input H/L Level Voltage	VIH	-	0.7*IOVCC	-	IOVCC	V
	VIL	-	GND	-	0.3IOVCC	V
Supply Current	I _{dd}	VCC&IOVCC =2.8V Pattern=Photo	-	8	-	mA
		VCC&IOVCC =2.8 V Pattern= RGB *1	-	10	15	mA

Note1:Maximum current display

1.5 Optical Characteristics

TFT LCD Module

VCC & IOVC= 2.8 V, Ta=25 °C

Item	Symbol		Condition	Min.	Typ.	Max.	unit	
Response time	Tr+Tf		Ta = 25 °C θX, θY = 0°	-	30	40	ms	Note 2
Viewing angle	Top	θY+	CR ≥ 10	-	80	-	Deg.	Note 4
	Bottom	θY-		-	80	-		
	Left	θX-		-	80	-		
	Right	θX+		-	80	-		
Contrast ratio		CR		650	800	-		Note 3
Color of CIE Coordinate (With B/L)	White	X	Ta = 25 °C θX , θY = 0°	0.24	0.29	0.34	-	Note1
		Y		0.26	0.31	0.36		
	Red	X		0.58	0.63	0.68		
		Y		0.29	0.34	0.39		
	Green	X		0.26	0.31	0.36		
		Y		0.57	0.62	0.67		
	Blue	X		0.09	0.14	0.19		
		Y		0.00	0.05	0.10		
Average Brightness Pattern=white display (With B/L)*1	IF		IF= 40 mA	800	1000	-	cd/m ²	Note1
Uniformity (With B/L)*2	ΔB		IF=40mA	70	-	-	%	Note1

Note 1:

*1 : $\Delta B = B(\text{min}) / B(\text{max}) * 100\%$

*2 : Measurement Condition for Optical Characteristics:

- a : Environment: $25^{\circ}\text{C} \pm 5^{\circ}\text{C}$ / $60 \pm 20\% \text{R.H}$, no wind , dark room below 10 Lux at typical lamp current and typical operating frequency.
- b : Measurement Distance: 500 ± 50 mm , ($\theta = 0^{\circ}$)
- c : Equipment: TOPCON BM-7 fast , (field 1°) , after 10 minutes operation.
- d : The uncertainty of the C.I.E coordinate measurement ± 0.01 , Average Brightness $\pm 4\%$

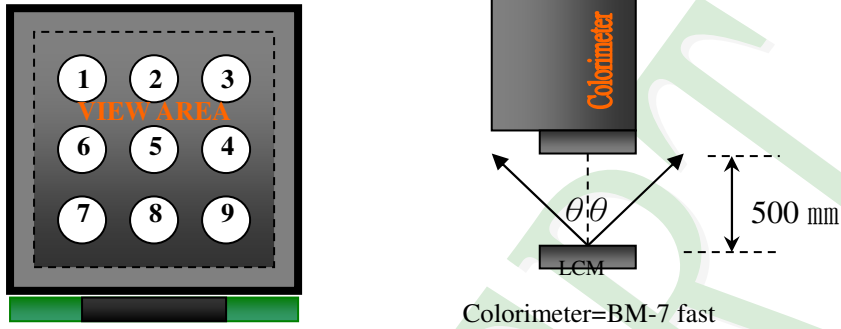

To be measured at the center area of panel with a viewing cone of 1° by Topcon luminance meter BM-7, after 10 minutes operation (module)

Note2: Definition of response time:

The output signals of photo detector are measured when the input signals are changed from "black" to "white"(falling time) and from "white" to "black"(rising time), respectively. The response time is defined as the time interval between the 10% and 90% of Amplitudes.

Refer to figure as below:

Normally White



Normally Black

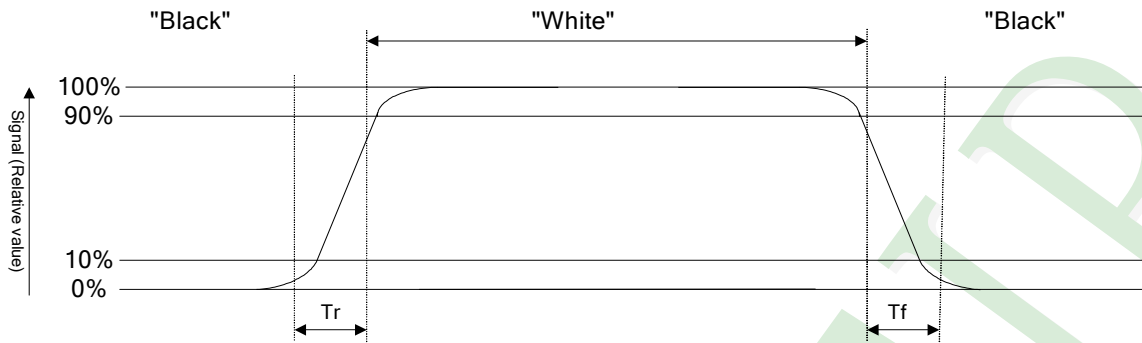

Note3: Definition of contrast ratio:

Contrast ratio is calculated with the following formula

$$\text{Contrast ratio (CR)} = \frac{\text{Photo detector output when LCD is at "White" state}}{\text{Photo detector output when LCD is at "Black" state}}$$

Note4: Definition of viewing angle:

Refer to figure as below:

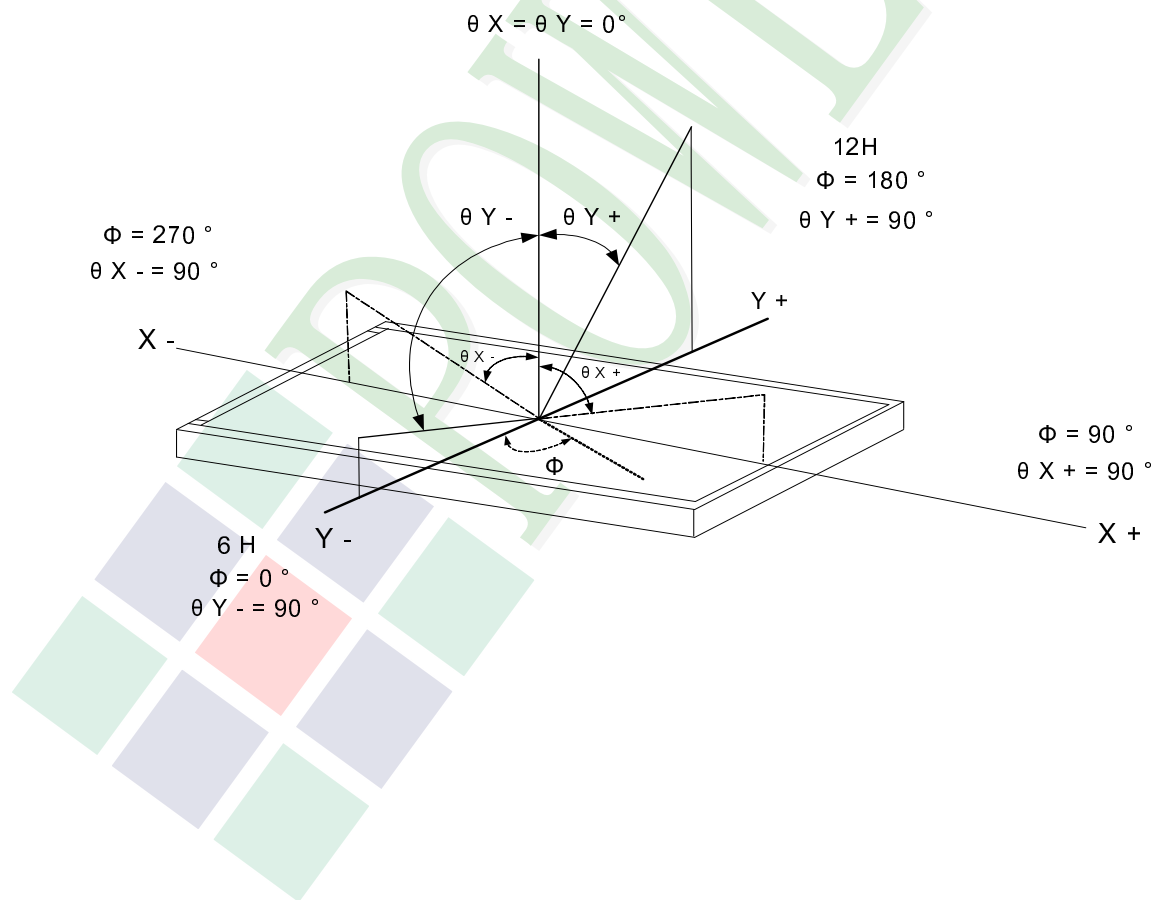

1.6 Backlight Characteristics

Maximum Ratings

Item	Symbol	Conditions	Min.	Max.	Unit
LED Forward Current	IF	Ta =25°C	-	30*2	mA
LED Reverse Voltage	VR		-	5	V
Power consumption	Pd			400*2	mW

Electrical / Optical Characteristics

Item	Symbol	Conditions	Min.	Typ.	Max.	Unit
Forward Voltage	VF	If= 40mA	10.8	12	13.2	
Average Brightness (Without LCD)	IV		13000	14000	16000	cd/m ²
CIE Color Coordinate (Without LCD)	X		-	0.30	-	-
	Y		-	0.30	-	-
Color	White					

B/L Internal Circuit Diagram:

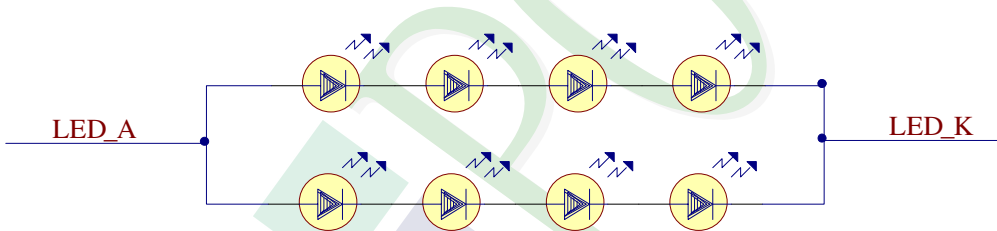

Other Description

Item	Conditions	Description
Life Time	Ta =25°C IF= 40mA	50,000 hrs

2. MODULE STRUCTURE

2.1 Counter Drawing

2.1.1 LCM Mechanical Diagram

* See Appendix

2.1.2 Block Diagram

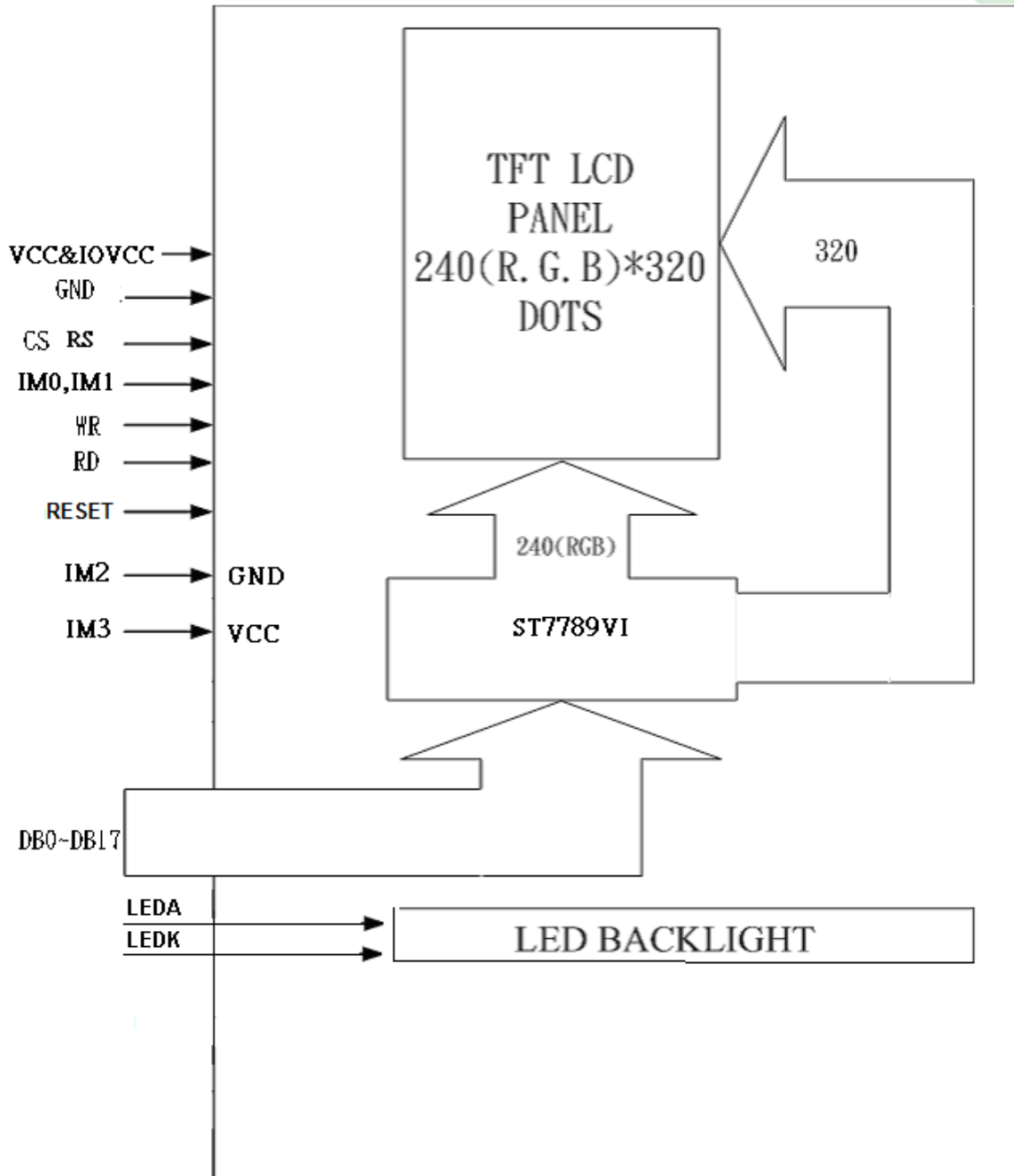

Note: IM2 FPC Circuit Internal Pull Low

IM3 FPC Circuit Internal Pull Hgh

2.2 Interface Pin Description

Pin No.	Symbol	Function			
1	GND	Signal ground.(0V)			
2	GND	Signal ground.(0V)			
3	ID	Identify pin ---1K Pullup to IOVCC			
4	IM0	Interface mode pin			
5	IM1	External setting pins			
		IM1	IM0	Interface Mode	DB PIN
		0	0	80-16-bit parallel interface II	DB17-10, DB8-1
		0	1	80-8-bit parallel interface II	DB17-10
		1	0	80-18-bit parallel interface II	DB17-0
1	1	80-9-bit parallel interface II	DB17-9		
6	RESET	Reset input pin for TFT LCD. When RESET is "L", initialization is executed			
7	DB17	Bi-directional data bus			
8	DB16	Bi-directional data bus			
9	DB15	Bi-directional data bus			
10	DB14	Bi-directional data bus			
11	DB13	Bi-directional data bus			
12	DB12	Bi-directional data bus			
13	DB11	Bi-directional data bus			
14	DB10	Bi-directional data bus			
15	DB9	Bi-directional data bus			
16	DB8	Bi-directional data bus			
17	DB7	Bi-directional data bus			
18	DB6	Bi-directional data bus			
19	DB5	Bi-directional data bus			
20	DB5	Bi-directional data bus			
21	DB3	Bi-directional data bus			
22	DB2	Bi-directional data bus			
23	DB1	Bi-directional data bus			
24	DB0	Bi-directional data bus			

Pin No.	Symbol	Function
25	RD	Read data at the rising edge
26	WR	Write signal input , active at Low.
27	RS	When RS = 0: Command. When RS = 1: Display data
28	CS	Chip select signal , Active at "L"
29	IOVCC	Power supply of Digital Circuit
30	IOVCC	Power supply of Digital Circuit
31	VCC	Power supply of Analog circuit.
32	VCC	Power supply of Analog circuit.
33	GND	Signal ground.(0V)
34	LEDA	Power supply for LED Backlight Anode input
35	LEDK	Power supply for LED Backlight Cathode input
36	GND	Signal ground.(0V)
37	GND	Signal ground.(0V)
38	GND	Signal ground.(0V)
39	GND	Signal ground.(0V)

2.2.1 Application Notes:

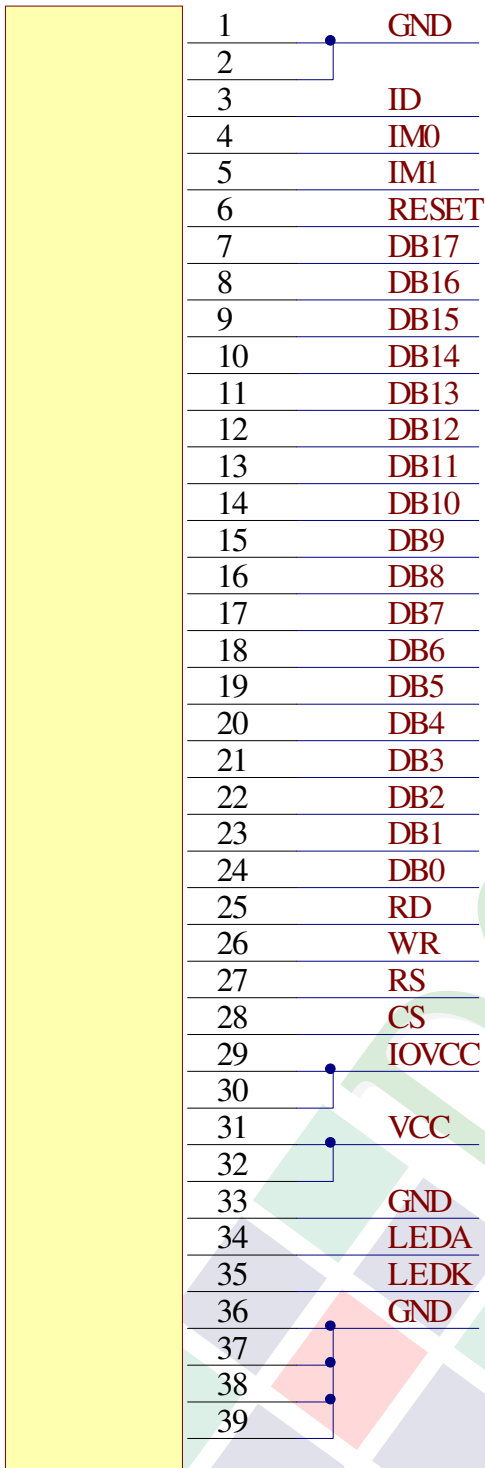

FPC Interface

2.2.2 Refer Initial code:

```
void Initial_Main(void)                // For ST7789VI
{
    WriteCOM_Main(0x11); //exit sleep
    Delay(120);
    WriteCOM_Main(0x36); //Memory access Control
    WriteDAT_Main(0x00);

    WriteCOM_Main(0x3A); //Interface pixel format
    WriteDAT_Main(0x06);

//-----ST7789VI Frame rate setting-----//
    WriteCOM_Main(0xB2);
    WriteDAT_Main(0x0c);
    WriteDAT_Main(0x0c);
    WriteDAT_Main(0x00);
    WriteDAT_Main(0x33);
    WriteDAT_Main(0x33);

    WriteCOM_Main(0xB7);
    WriteDAT_Main(0x35);
//-----ST7789VI Power setting-----//

    WriteCOM_Main(0xbb); //VCOMS Setting
    WriteDAT_Main(0x3D); //

    WriteCOM_Main(0xc0);
    WriteDAT_Main(0x2c);

    WriteCOM_Main(0xc2);
    WriteDAT_Main(0x01);

    WriteCOM_Main(0xc3);
    WriteDAT_Main(0x0B);

    WriteCOM_Main(0xc4);
    WriteDAT_Main(0x20);
```

```
WriteCOM_Main(0xc6);  
WriteDAT_Main(0xE3);
```

```
WriteCOM_Main(0xd0);  
WriteDAT_Main(0xa4);  
WriteDAT_Main(0xa3);
```

```
WriteCOM_Main(0x21);
```

```
//-----set gamma-----
```

```
WriteCOM_Main(0xe0); //set gamma  
WriteDAT_Main(0x70);  
WriteDAT_Main(0x04);  
WriteDAT_Main(0x08);  
WriteDAT_Main(0x07);  
WriteDAT_Main(0x06);  
WriteDAT_Main(0x04);  
WriteDAT_Main(0x21);  
WriteDAT_Main(0x42);  
WriteDAT_Main(0x38);  
WriteDAT_Main(0x37);  
WriteDAT_Main(0x13);  
WriteDAT_Main(0x13);  
WriteDAT_Main(0x25);  
WriteDAT_Main(0x2C);
```

```
WriteCOM_Main(0xe1); //set gamma  
WriteDAT_Main(0x70);  
WriteDAT_Main(0x00);  
WriteDAT_Main(0x02);  
WriteDAT_Main(0x08);  
WriteDAT_Main(0x07);  
WriteDAT_Main(0x22);  
WriteDAT_Main(0x1F);  
WriteDAT_Main(0x23);  
WriteDAT_Main(0x39);
```



```
WriteDAT_Main(0x28);  
WriteDAT_Main(0x14);  
WriteDAT_Main(0x15);  
WriteDAT_Main(0x26);  
WriteDAT_Main(0x2D);
```

```
WriteCOM_Main(0x29);//Display on
```

```
WriteCOM_Main(0xE9);//Equalize time control  
WriteDAT_Main(0x02);  
WriteDAT_Main(0x11);  
WriteDAT_Main(0x03);  
}
```

2.3 Timing Characteristics

Parallel 18/16/9/8-Bit RGB Interface Timing

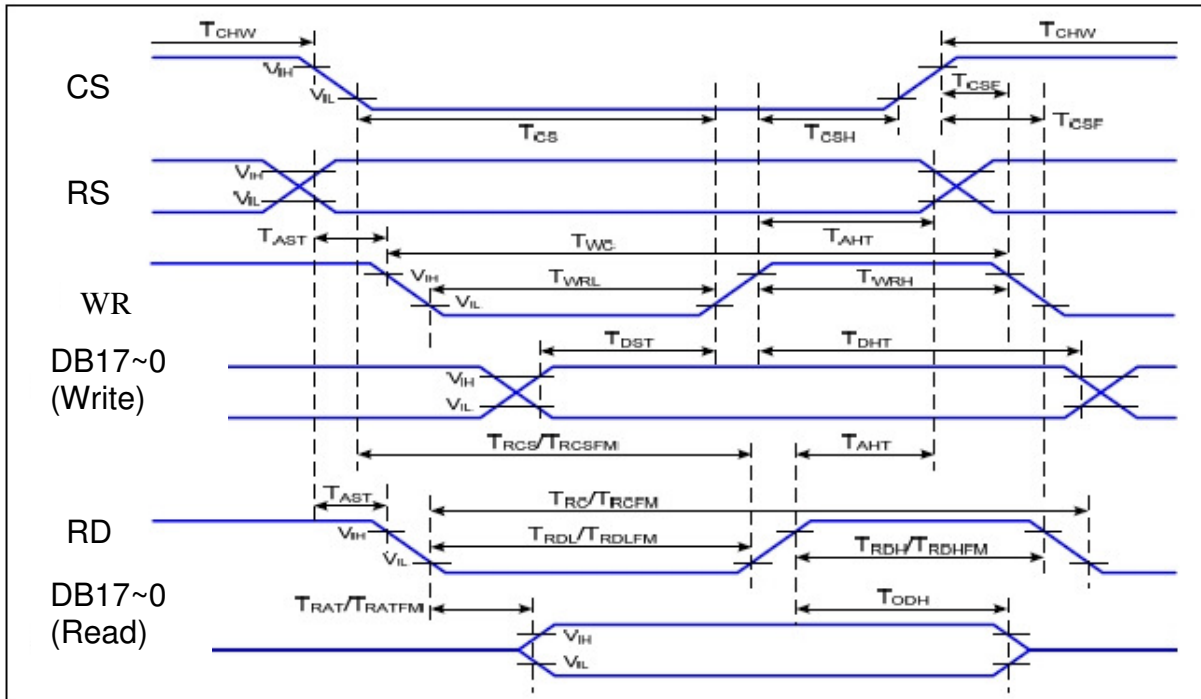

VCC&IOVCC= 2.8V, Ta=25°C

Signal	Symbol	Parameter	Min	Max	Unit
RS	TAST	Address Setup time	0	-	ns
	TAHT	Address Hold time(Write/Read)	10	-	ns
CS	TCHW	CS "H" pulse width	0	-	ns
	TCS	Chip select Setup time (Write)	15	-	
	TRCS	Chip Select setup time (Read ID)	45		ns
	TRCSFM	Chip select Setup time (Read FM)	355	-	ns
	TCSF	Chip select wait time(Write/Read)	10	-	ns
	TCSH	Chip select hold time	10	-	ns
WR	tWC	Write Cycle	66	-	ns
	tWRH	Control pulse "H" duration	15	-	ns
	tWRL	Control pulse "L" duration	15	-	ns
RD(FM)	tRCFM	Read Cycle(FM)	450	-	ns
	tRDHFM	Read Control H duration (FM)	90	-	ns
	tRDLFM	Read Control L duration (FM)	355	-	ns
RD(ID)	trc	Read Cycle(ID)	160		ns
	trdh	Read Control pulse H duration	90		ns
	trdl	Read Control pulse L duration	45		ns

Signal	Symbol	Parameter	Min	Max	Unit
DB17~DB0	tDST	Write Data setup time	10		ns
	tRAT	Read access time		40	ns
	tRATFM	Read access time	-	340	ns
	tODH	Read Output disable time	20	80	ns

LCD Reset

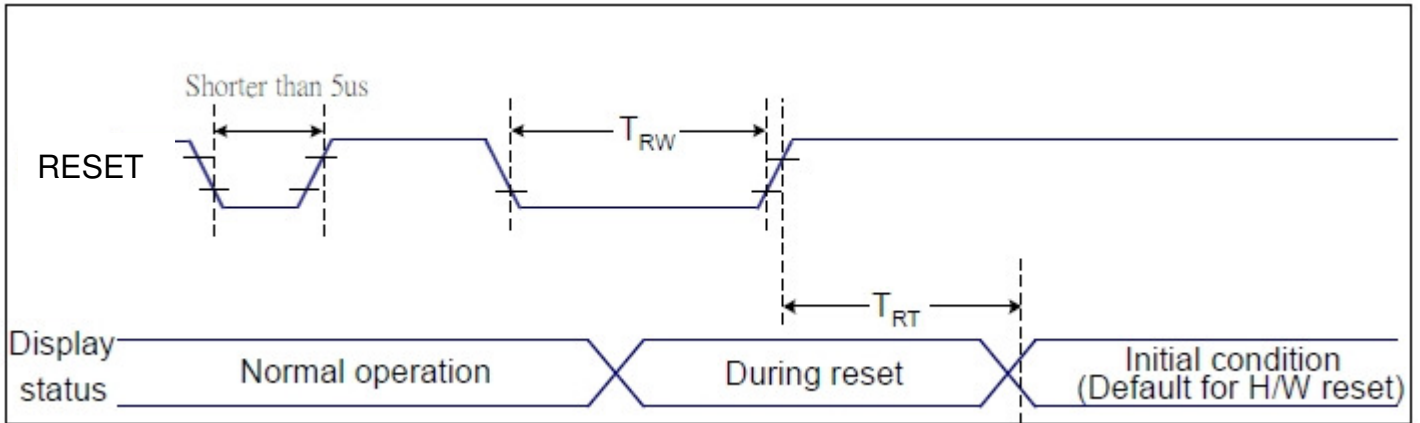

Signal	Symbol	Parameter	Min.	Max.	Unit
RESET	TRW	Reset pulse duration	10	-	us
	TRT	Reset cancel	-	5 (Note1,5)	ms
			-	120 (Note1,6,7)	ms

Note 1: The reset cancel includes also required time for loading ID bytes, VCOM setting and other settings from NV memory to registers. This loading is done every time when there is HW reset cancel time (tRT) within 5 ms after a rising edge of RESX.

Note 2: Spike due to an electrostatic discharge on RESX line does not cause irregular system reset according to the table below: -

RESX Pulse	Action
Shorter than 5us	Reset Rejected
Longer than 10us	Reset
Between 5us and 10us	Reset starts

Note 3: During the Resetting period, the display will be blanked (The display is entering blanking sequence, which maximum time is 120 ms, when Reset Starts in Sleep Out -mode. The display remains the blank state in Sleep In -mode.) And then return to Default condition for Hardware Reset.

Note 4: Spike Rejection also applies during a valid reset pulse as shown below:

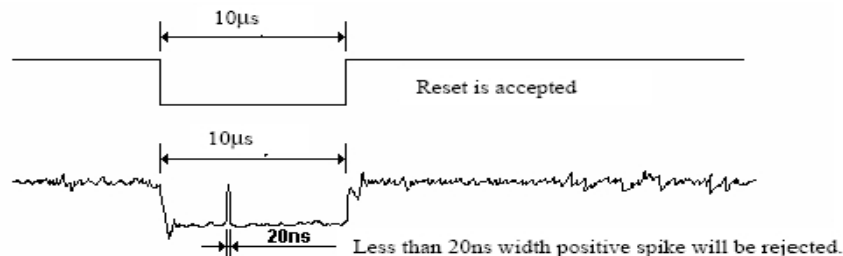

Note 5: When Reset applied during Sleep In Mode.

Note 6: When Reset applied during Sleep Out Mode.

Note 7: It is necessary to wait 5msec after releasing RESX before sending commands. Also Sleep Out command cannot be sent for 120msec.

3. QUALITY ASSURANCE SYSTEM

3.1 Quality Assurance Flow Chart

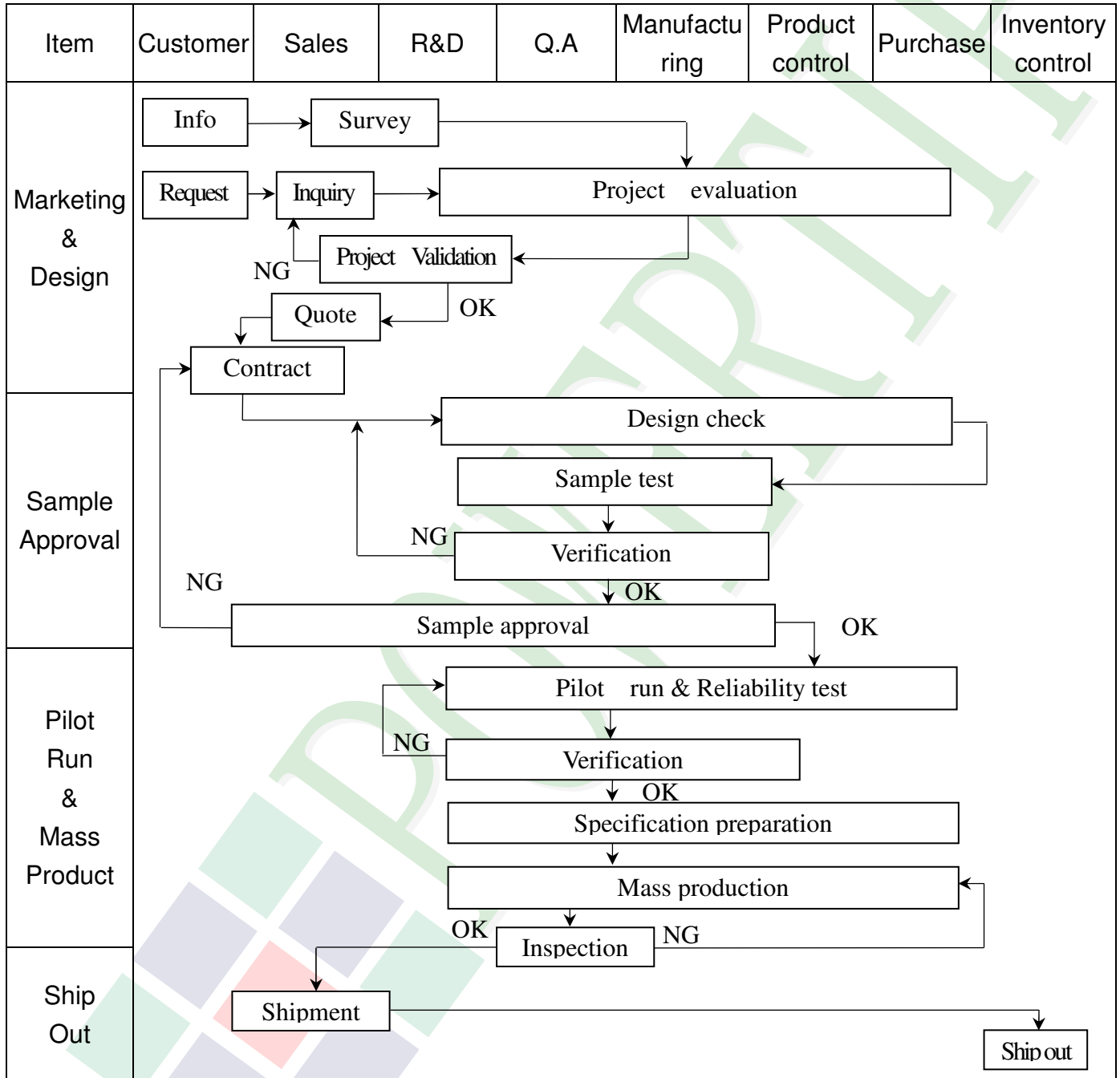

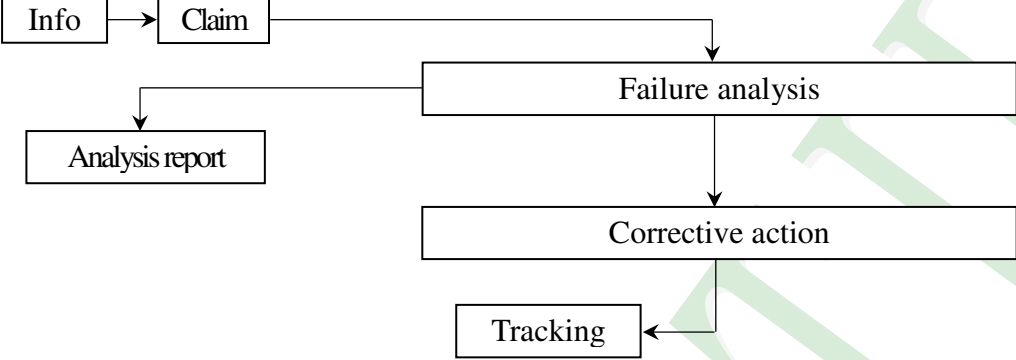
Item	Customer	Sales	R&D	Q.A	Manufacturing	Product control	Purchase	Inventory control
Sales Service	 <pre> graph TD Info[Info] --> Claim[Claim] Claim --> FA[Failure analysis] Claim --> AR[Analysis report] FA --> CA[Corrective action] CA --> Tracking[Tracking] </pre>							
Q.A Activity	1. ISO 9001 Maintenance Activities 3. Equipment calibration 5. Standardization Management				2. Process improvement proposal 4. Education And Training Activities			

3.2. Inspection Specification

- ◆ Scope : The document shall be applied to TFT-LCD Module for less than 3.5" (Ver.B01).
- ◆ Inspection Standard : MIL-STD-105E Table Normal Inspection Single Sampling Level II.
- ◆ Equipment : Gauge 、 MIL-STD 、 Powertip Tester 、 Sample
- ◆ Defect Level : Major Defect AQL : 0.4 ; Minor Defect AQL : 1.5
- ◆ OUT Going Defect Level : Sampling.
- ◆ Standard of the product appearance test :

a. Manner of appearance test :

- (1). The test best be under 20W×2 fluorescent light , and distance of view must be at 30 cm.
- (2). The test direction is base on about around 45° of vertical line.

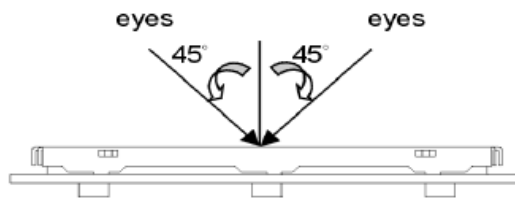

(3). Definition of area.

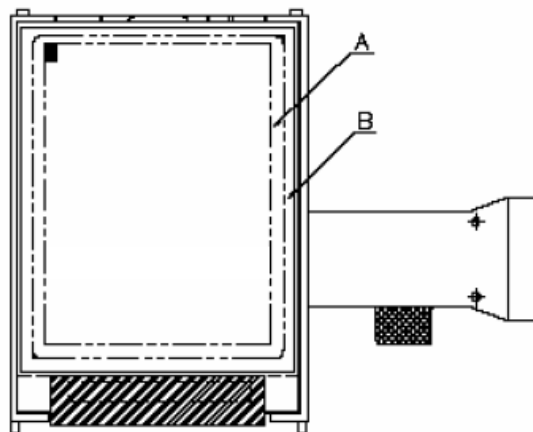

A area : viewing area

B area : Outside of viewing area

(4). Standard of inspection : (Unit : mm)



◆ Specification For TFT-LCD Module Less Than 3.5" :

(Ver.B01)

NO	Item	Criterion	Level												
01	Product condition	1. 1 The part number is inconsistent with work order of production.	Major												
		1. 2 Mixed product types.	Major												
		1. 3 Assembled in inverse direction.	Major												
02	Quantity	2. 1 The quantity is inconsistent with work order of production.	Major												
03	Outline dimension	3. 1 Product dimension and structure must conform to structure diagram.	Major												
04	Electrical Testing	4. 1 Missing line character and icon.	Major												
		4. 2 No function or no display.	Major												
		4. 3 Display malfunction.	Major												
		4. 4 LCD viewing angle defect.	Major												
		4. 5 Current consumption exceeds product specifications.	Major												
05	Dot defect (Bright dot 、 Dark dot) On -display	<table border="1" style="margin-left: auto; margin-right: auto;"> <thead> <tr> <th colspan="2">Item</th> <th>Acceptance (Q'ty)</th> </tr> </thead> <tbody> <tr> <td rowspan="4" style="text-align: center; vertical-align: middle;">Dot Defect</td> <td style="text-align: center;">Bright Dot</td> <td style="text-align: center;">≤ 2</td> </tr> <tr> <td style="text-align: center;">Dark Dot</td> <td style="text-align: center;">≤ 3</td> </tr> <tr> <td style="text-align: center;">Joint Dot</td> <td style="text-align: center;">≤ 2</td> </tr> <tr> <td style="text-align: center;">Total</td> <td style="text-align: center;">≤ 3</td> </tr> </tbody> </table> <p>5. 1 Inspection pattern : full white , full black , Red , Green and blue screens.</p> <p>5. 2 It is defined as dot defect if defect area $> 1/2$ dot.</p> <p>5. 3 The distance between two dot defect ≥ 5 mm.</p>	Item		Acceptance (Q'ty)	Dot Defect	Bright Dot	≤ 2	Dark Dot	≤ 3	Joint Dot	≤ 2	Total	≤ 3	Minor
Item		Acceptance (Q'ty)													
Dot Defect	Bright Dot	≤ 2													
	Dark Dot	≤ 3													
	Joint Dot	≤ 2													
	Total	≤ 3													

◆ Specification For TFT-LCD Module Less Than 3.5" :

(Ver.B01)

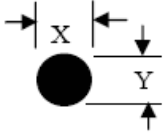
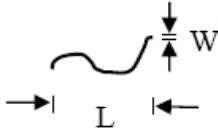
NO	Item	Criterion	Level																																								
06	<p>Black or white dot、scratch、contamination</p> <p>Round type</p>  <p>$\Phi = (x + y) / 2$</p> <p>Line type</p> 	<p>6.1 Round type (Non-display or display) :</p> <table border="1"> <thead> <tr> <th rowspan="2">Dimension (diameter : Φ)</th> <th colspan="2">Acceptance (Q'ty)</th> </tr> <tr> <th>A area</th> <th>B area</th> </tr> </thead> <tbody> <tr> <td>$\Phi \leq 0.15$</td> <td colspan="2">Ignore</td> </tr> <tr> <td>$0.15 < \Phi \leq 0.20$</td> <td>2</td> <td rowspan="3">Ignore</td> </tr> <tr> <td>$0.20 < \Phi \leq 0.30$</td> <td>2</td> </tr> <tr> <td>$\Phi > 0.30$</td> <td>0</td> </tr> <tr> <td>Total</td> <td colspan="2">3</td> </tr> </tbody> </table> <p>6.2 Line type(Non-display or display) :</p> <table border="1"> <thead> <tr> <th colspan="2">Dimension</th> <th colspan="2">Acceptance (Q'ty)</th> </tr> <tr> <th>Length (L)</th> <th>Width (W)</th> <th>A area</th> <th>B area</th> </tr> </thead> <tbody> <tr> <td>---</td> <td>$W \leq 0.03$</td> <td>Ignore</td> <td rowspan="4">Ignore</td> </tr> <tr> <td>$L \leq 5.0$</td> <td>$0.03 < W \leq 0.05$</td> <td>3</td> </tr> <tr> <td>---</td> <td>$W > 0.05$</td> <td>As round type</td> </tr> <tr> <td colspan="2">Total</td> <td colspan="2">3</td> </tr> </tbody> </table>	Dimension (diameter : Φ)	Acceptance (Q'ty)		A area	B area	$\Phi \leq 0.15$	Ignore		$0.15 < \Phi \leq 0.20$	2	Ignore	$0.20 < \Phi \leq 0.30$	2	$\Phi > 0.30$	0	Total	3		Dimension		Acceptance (Q'ty)		Length (L)	Width (W)	A area	B area	---	$W \leq 0.03$	Ignore	Ignore	$L \leq 5.0$	$0.03 < W \leq 0.05$	3	---	$W > 0.05$	As round type	Total		3		Minor
Dimension (diameter : Φ)	Acceptance (Q'ty)																																										
	A area	B area																																									
$\Phi \leq 0.15$	Ignore																																										
$0.15 < \Phi \leq 0.20$	2	Ignore																																									
$0.20 < \Phi \leq 0.30$	2																																										
$\Phi > 0.30$	0																																										
Total	3																																										
Dimension		Acceptance (Q'ty)																																									
Length (L)	Width (W)	A area	B area																																								
---	$W \leq 0.03$	Ignore	Ignore																																								
$L \leq 5.0$	$0.03 < W \leq 0.05$	3																																									
---	$W > 0.05$	As round type																																									
Total		3																																									
07	Polarizer Bubble	<table border="1"> <thead> <tr> <th rowspan="2">Dimension (diameter : Φ)</th> <th colspan="2">Acceptance (Q'ty)</th> </tr> <tr> <th>A area</th> <th>B area</th> </tr> </thead> <tbody> <tr> <td>$\Phi \leq 0.20$</td> <td colspan="2">Ignore</td> </tr> <tr> <td>$0.20 < \Phi \leq 0.50$</td> <td>3</td> <td rowspan="3">Ignore</td> </tr> <tr> <td>$\Phi > 0.50$</td> <td>0</td> </tr> <tr> <td>Total</td> <td colspan="2">3</td> </tr> </tbody> </table>	Dimension (diameter : Φ)	Acceptance (Q'ty)		A area	B area	$\Phi \leq 0.20$	Ignore		$0.20 < \Phi \leq 0.50$	3	Ignore	$\Phi > 0.50$	0	Total	3		Minor																								
Dimension (diameter : Φ)	Acceptance (Q'ty)																																										
	A area	B area																																									
$\Phi \leq 0.20$	Ignore																																										
$0.20 < \Phi \leq 0.50$	3	Ignore																																									
$\Phi > 0.50$	0																																										
Total	3																																										

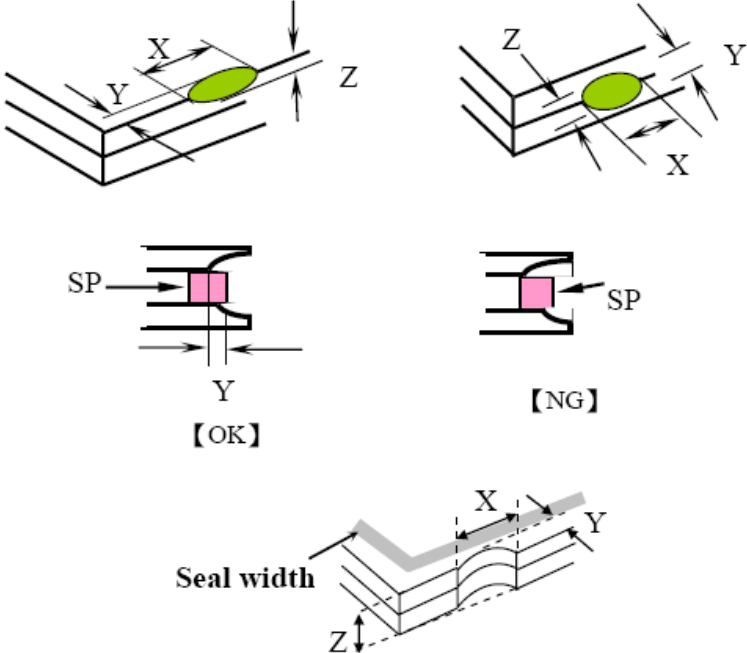
NO	Item	Criterion	Level						
08	The crack of glass	<p>Symbols :</p> <p>X : The length of crack Z : The thickness of crack t : The thickness of glass</p> <p>Y : The width of crack. W : terminal length a : LCD side length</p>	Minor						
		<p>8.1 General glass chip :</p> <p>8.1.1 Chip on panel surface and crack between panels:</p> <div style="text-align: center;">  </div> <table border="1" data-bbox="550 1444 1348 1736" style="margin-left: auto; margin-right: auto;"> <thead> <tr> <th>X</th> <th>Y</th> <th>Z</th> </tr> </thead> <tbody> <tr> <td>$\leq a$</td> <td>Crack can't enter viewing area</td> <td>$\leq 1/2 t$</td> </tr> <tr> <td>$\leq a$</td> <td>Crack can't exceed the half of SP width.</td> <td>$1/2 t < Z \leq 2 t$</td> </tr> </tbody> </table>		X	Y	Z	$\leq a$	Crack can't enter viewing area	$\leq 1/2 t$
X	Y	Z							
$\leq a$	Crack can't enter viewing area	$\leq 1/2 t$							
$\leq a$	Crack can't exceed the half of SP width.	$1/2 t < Z \leq 2 t$							

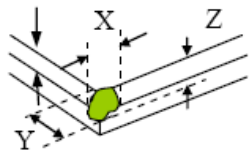
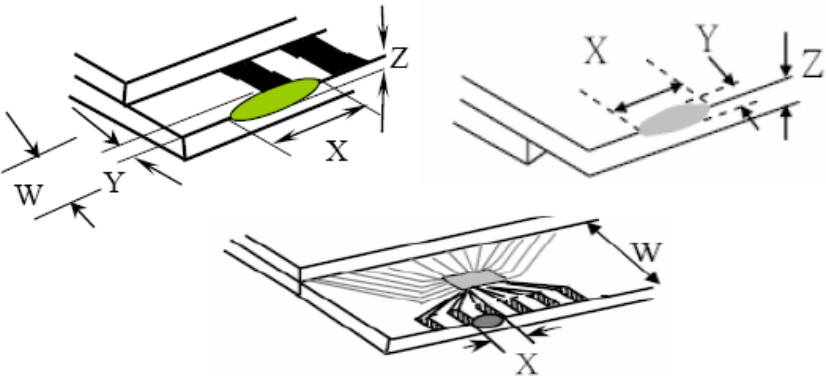

NO	Item	Criterion	Level									
08	The crack of glass	<p>Symbols :</p> <p>X : The length of crack Y : The width of crack. Z : The thickness of crack W : terminal length t : The thickness of glass a : LCD side length</p> <hr/> <p>8.1.2 Corner crack :</p>  <table border="1" data-bbox="533 779 1337 1066"> <thead> <tr> <th>X</th> <th>Y</th> <th>Z</th> </tr> </thead> <tbody> <tr> <td>$\leq 1/5 a$</td> <td>Crack can't enter viewing area</td> <td>$Z \leq 1/2 t$</td> </tr> <tr> <td>$\leq 1/5 a$</td> <td>Crack can't exceed the half of SP width.</td> <td>$1/2 t < Z \leq 2 t$</td> </tr> </tbody> </table>	X	Y	Z	$\leq 1/5 a$	Crack can't enter viewing area	$Z \leq 1/2 t$	$\leq 1/5 a$	Crack can't exceed the half of SP width.	$1/2 t < Z \leq 2 t$	Minor
		X	Y	Z								
$\leq 1/5 a$	Crack can't enter viewing area	$Z \leq 1/2 t$										
$\leq 1/5 a$	Crack can't exceed the half of SP width.	$1/2 t < Z \leq 2 t$										
<p>8.2 Protrusion over terminal :</p> <p>8.2.1 Chip on electrode pad :</p>  <table border="1" data-bbox="571 1659 1347 1832"> <thead> <tr> <th></th> <th>X</th> <th>Y</th> <th>Z</th> </tr> </thead> <tbody> <tr> <td>Front</td> <td>$\leq a$</td> <td>$\leq 1/2 W$</td> <td>$\leq t$</td> </tr> <tr> <td>Back</td> <td>$\leq a$</td> <td>$\leq W$</td> <td>$\leq 1/2 t$</td> </tr> </tbody> </table>		X	Y	Z	Front	$\leq a$	$\leq 1/2 W$	$\leq t$	Back	$\leq a$	$\leq W$	$\leq 1/2 t$
	X	Y	Z									
Front	$\leq a$	$\leq 1/2 W$	$\leq t$									
Back	$\leq a$	$\leq W$	$\leq 1/2 t$									

◆ Specification For TFT-LCD Module Less Than 3.5" :

(Ver.B01)

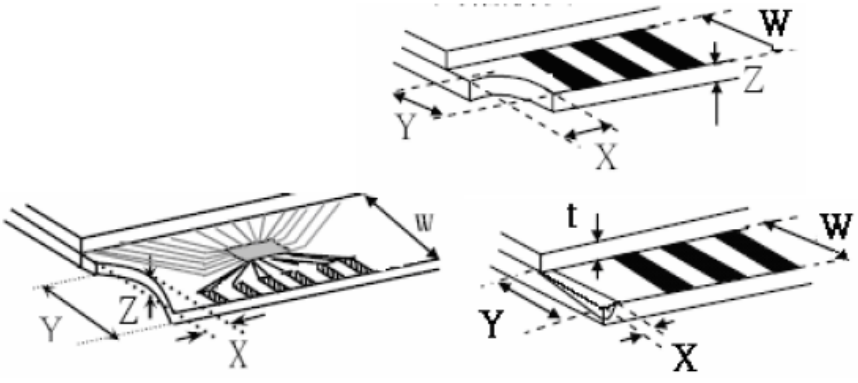
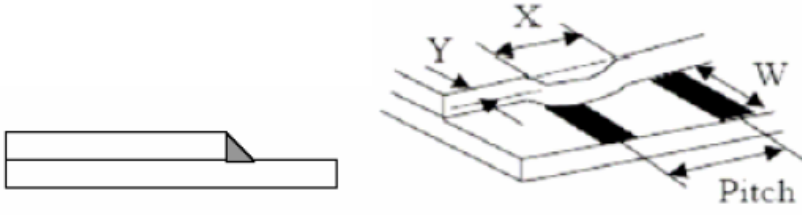
NO	Item	Criterion	Level												
08	The crack of glass	<p>Symbols :</p> <p>X : The length of crack Y : The width of crack. Z : The thickness of crack W : terminal length t : The thickness of glass a : LCD side length</p> <hr/> <p>8.2.2 Non-conductive portion :</p>  <table border="1" data-bbox="630 952 1252 1108" style="margin-left: auto; margin-right: auto;"> <thead> <tr> <th>X</th> <th>Y</th> <th>Z</th> </tr> </thead> <tbody> <tr> <td>$\leq 1/3 a$</td> <td>$\leq W$</td> <td>$\leq t$</td> </tr> </tbody> </table> <p>⊙ If the chipped area touches the ITO terminal, over 2/3 of the ITO must remain and be inspected according to electrode terminal specifications.</p> <p>8.2.3 Glass remain :</p>  <table border="1" data-bbox="550 1747 1236 1870" style="margin-left: auto; margin-right: auto;"> <thead> <tr> <th>X</th> <th>Y</th> <th>Z</th> </tr> </thead> <tbody> <tr> <td>$\leq a$</td> <td>$\leq 1/3 W$</td> <td>$\leq t$</td> </tr> </tbody> </table>	X	Y	Z	$\leq 1/3 a$	$\leq W$	$\leq t$	X	Y	Z	$\leq a$	$\leq 1/3 W$	$\leq t$	Minor
X	Y	Z													
$\leq 1/3 a$	$\leq W$	$\leq t$													
X	Y	Z													
$\leq a$	$\leq 1/3 W$	$\leq t$													

◆ Specification For TFT-LCD Module Less Than 3.5" :

(Ver.B01)

NO	Item	Criterion	Level
09	Backlight elements	9. 1 Backlight can't work normally.	Major
		9. 2 Backlight doesn't light or color is wrong.	Major
		9. 3 Illumination source flickers when lit.	Major
10	General appearance	10. 1 Pin type 、 quantity 、 dimension must match type in structure diagram.	Major
		10. 2 No short circuits in components on PCB or FPC .	Major
		10. 3 Parts on PCB or FPC must be the same as on the production characteristic chart .There should be no wrong parts , missing parts or excess parts.	Major
		10. 4 Product packaging must the same as specified on packaging specification sheet.	Minor
		10. 5 The folding and peeled off in polarizer are not acceptable.	Minor
		10. 6 The PCB or FPC between B/L assembled distance(PCB or FPC) is ≤ 1.5 mm.	Minor



4. RELIABILITY TEST

4.1 Reliability Test Condition

(Ver.B01)

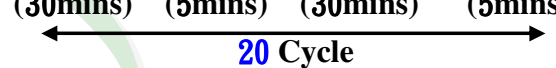
NO.	TEST ITEM	TEST CONDITION										
1	High Temperature Storage Test	Keep in +80 ±2°C 240 hrs Surrounding temperature, then storage at normal condition 4hrs.										
2	Low Temperature Storage Test	Keep in -30 ±2°C 240 hrs Surrounding temperature, then storage at normal condition 4hrs.										
3	High Temperature / High Humidity Storage Test	Keep in +60°C / 90% R.H duration for 240 hrs Surrounding temperature, then storage at normal condition 4hrs. (Excluding the polarizer)										
4	ESD Test	Air Discharge: (include mobile phone) Apply 2 KV with 5 times Discharge for each polarity +/-	Contact Discharge: (include mobile phone) Apply 250V with 5 times discharge for each polarity +/-									
		<ol style="list-style-type: none"> 1. Temperature ambience: 15°C ~ 35°C 2. Humidity relative: 30% ~ 60% 3. Energy Storage Capacitance(Cs+Cd): 150pF±10% 4. Discharge Resistance(Rd): 330Ω±10% 5. Discharge, mode of operation: Single Discharge (time between successive discharges at least 1 s) (Tolerance if the output voltage indication: ±5%) 										
5	Temperature Cycling Storage Test	<p style="text-align: center;"> -30°C → +25°C → +80°C → +25°C (30mins) (5mins) (30mins) (5mins)  20 Cycle </p> Surrounding temperature, then storage at normal condition 4hrs.										
6	Vibration Test (Packaged)	<ol style="list-style-type: none"> 1. Sine wave 10~55 Hz frequency (1 min) 2. The amplitude of vibration : 1.5 mm 3. Each direction (X、Y、Z) duration for 2 Hrs 										
7	Drop Test (Packaged)	<table border="1" style="margin-left: auto; margin-right: auto;"> <thead> <tr> <th>Packing Weight (Kg)</th> <th>Drop Height (cm)</th> </tr> </thead> <tbody> <tr> <td style="text-align: center;">0 ~ 45.4</td> <td style="text-align: center;">122</td> </tr> <tr> <td style="text-align: center;">45.4 ~ 90.8</td> <td style="text-align: center;">76</td> </tr> <tr> <td style="text-align: center;">90.8 ~ 454</td> <td style="text-align: center;">61</td> </tr> <tr> <td style="text-align: center;">Over 454</td> <td style="text-align: center;">46</td> </tr> </tbody> </table> <p style="text-align: center;">Drop direction : ※ 1 corner / 3 edges / 6 sides each 1times</p>	Packing Weight (Kg)	Drop Height (cm)	0 ~ 45.4	122	45.4 ~ 90.8	76	90.8 ~ 454	61	Over 454	46
Packing Weight (Kg)	Drop Height (cm)											
0 ~ 45.4	122											
45.4 ~ 90.8	76											
90.8 ~ 454	61											
Over 454	46											

5. PRECAUTION RELATING PRODUCT HANDLING

5.1 SAFETY

- 5.1.1 If the LCD panel breaks , be careful not to get the liquid crystal to touch your skin.
- 5.1.2 If the liquid crystal touches your skin or clothes , please wash it off immediately by using soap and water.

5.2 HANDLING

- 5.2.1 Avoid any strong mechanical shock which can break the glass.
- 5.2.2 Avoid static electricity which can damage the CMOS LSI—When working with the module , be sure to ground your body and any electrical equipment you may be using.
- 5.2.3 Do not remove the panel or frame from the module.
- 5.2.4 The polarizing plate of the display is very fragile. So , please handle it very carefully ,do not touch , push or rub the exposed polarizing with anything harder than an HB pencil lead (glass , tweezers , etc.)
- 5.2.5 Do not wipe the polarizing plate with a dry cloth , as it may easily scratch the surface of plate.
- 5.2.6 Do not touch the display area with bare hands , this will stain the display area.
- 5.2.7 Do not use ketonics solvent & aromatic solvent. Use with a soft cloth soaked with a cleaning naphtha solvent.
- 5.2.8 To control temperature and time of soldering is $320\pm 10^{\circ}\text{C}$ and 3-5 sec.
- 5.2.9 To avoid liquid (include organic solvent) stained on LCM .

5.3 STORAGE

- 5.3.1 Store the panel or module in a dark place where the temperature is $25^{\circ}\text{C} \pm 5^{\circ}\text{C}$ and the humidity is below 65% RH.
- 5.3.2 Do not place the module near organics solvents or corrosive gases.
- 5.3.3 Do not crush , shake , or jolt the module.

5.4 TERMS OF WARRANTY

- 5.4.1 Applicable warrant period
The period is within thirteen months since the date of shipping out under normal using and storage conditions.
- 5.4.2 Unaccepted responsibility
This product has been manufactured to your company's specification as a part for use in your company's general electronic products. It is guaranteed to perform according to delivery specifications. For any other use apart from general electronic equipment , we cannot take responsibility if the product is used in nuclear power control equipment , aerospace equipment , fire and security systems or any other applications in which there is a direct risk to human life and where extremely high levels of reliability are required.

LCM包裝規格書

LCM Packaging Specifications

Approve	Check	Contact
Jimmy	Tina	Clare

1. 包裝材料規格表 (Packaging Material) : (per carton)

No.	Item	Model	Dimensions (mm)	1Pcs Weight	Quantity	Total Weight
1	成品 (LCM)	PH240320T075-ZHA	50 X 70	0.0183	240	4.392
2	氣泡袋(1)Bubble Bag	BAG100080BWABA	100 X 80	0.0012	240	0.288
3	A2隔板(2)A2 Partition	BX29300070BMBA	293 X 70 X 2.5	0.0109	88	0.9592
4	B2隔板(3)B2 Partition	BX24500070BLBA	245 X 70 X 2.5	0.0094	32	0.3008
5	氣泡紙(4)Bubble Sheet	BAG280240BWABA	280 X 240	0.006	16	0.096
6	C2內盒(5)Product Box	BX31025580AABA	310 X 255 X 86	0.16	8	1.28
7	外紙箱(6)Carton	BX52732536CCBA	527 X 325 X 360	0.83	1	0.83
8						
9						

2. 一 整箱總重量 (Total LCD Weight in carton) : 8.15 Kg±10%

3. 單箱數量規格表 (Packaging Specifications and Quantity) :

(1)Quantity Of Spacer : A2 隔板 X 11 , B2 隔板 X 4

(2)Total LCM quantity in carton : quantity per box 30 x no of boxes 8 = 240

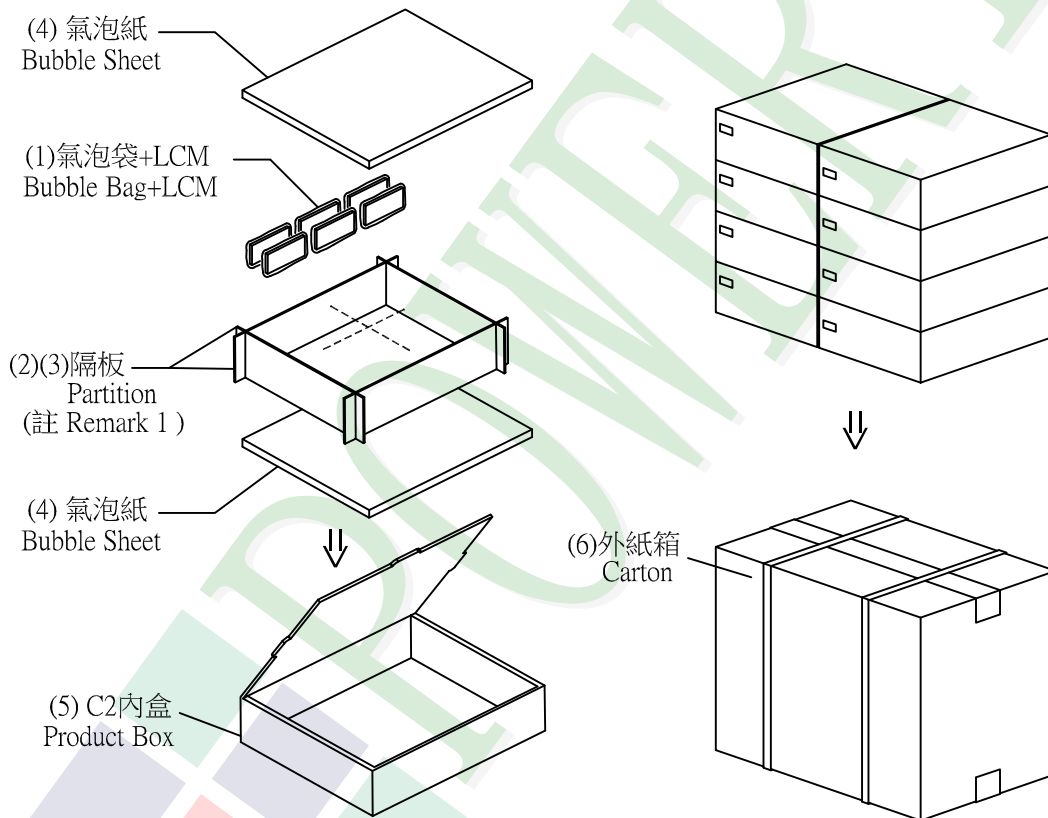

特 記 事 項 (REMARK)

1. LCM排放示意圖(前後間隔不放置):

1. LCM placed as figure showing:
(First and last slot should be empty)

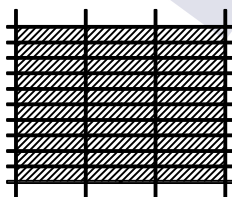

▨ 模組(LCM) X 1pcs.