

# MDS Medical AC-DC Adapter

## 19Volt, 150Watt / MDS-150CAB19 A



# 150CAB19 A



### Highlights & Features

- Safety Approvals to IEC 60601-1 3rd ed. & IEC 62368-1
- Risk management report available
- Low touch current (<0.1mA Normal & ,0.3mA single fault)
- Over-Voltage/Load/Temperature & Short Circuit protections
- 2.1 Million Hours MTBF
- 2 x MOPP (means of patient protection)
- 3 years warranty

### Safety Standards



CB Certified for worldwide use

<b>Model Number:</b>	MDS-150CAB19 A
<b>Unit Weight:</b>	0.52kg (18.4 ounces)
<b>Dimensions (W x L x H):</b>	65.0 x 150.0 x 32.0 mm 2.56 x 5.9 x 1.26 in

### General Description

The MDS series of external power supply comes with universal AC input at 90Vac to 264Vac. Other features include low touch current, risk management report available and the electric shock protection comply with 2 x MOPP. The MDS series is certified for EMC standards according to EN 55011 for industrial, scientific and medical (ISM) radio-frequency equipment and EN 55022 for Industrial Technology Equipment (ITE) radio-frequency equipment.

The MDS series come with both medical and ITE safety approvals including UL/cUL/CCC/CE and CB certification and are fully compliant with RoHS Directive for environmental protection.

### Model Information

Medical AC-DC Adapter

Model Number	Input Voltage Range	Output Voltage	Output Current
MDS-150CAB19 A	90-264Vac	19Vdc	7.9A

### Model Numbering

<b>MDS</b> <small>Delta Medical power Supply</small>	-	<b>150</b> <small>Max wattage in the product series. Maybe lower at some voltage. 150 → 150W</small>	<b>CAB</b> <small>Family Code</small>	<b>19</b> <small>Output Voltage Single Output: 19 for 19V</small>	<b>A</b>
---	---	---	--	--	----------

# MDS Medical AC-DC Adapter

## 19Volt, 150Watt / MDS-150CAB19 A

### Specifications

#### Input Ratings / Characteristics

Nominal Input Voltage	100-240Vac
Input Voltage Range	90-264Vac
Nominal Input Frequency	50-60Hz
Input Frequency Range	47-63Hz
Input Current (max.)	2A @ 115Vac, 1A @ 230Vac
Efficiency (typ.)	92%, Reference Fig.1
Standby Power (max.)	0.5W
Inrush Current (typ.)	37A @ 230Vac
Touch Current (max.)	0.1mA @ 264Vac NC <sup>1)</sup> , 0.3mA @ 264Vac SFC <sup>2)</sup>

1) NC: normal condition

2) SFC: single fault condition

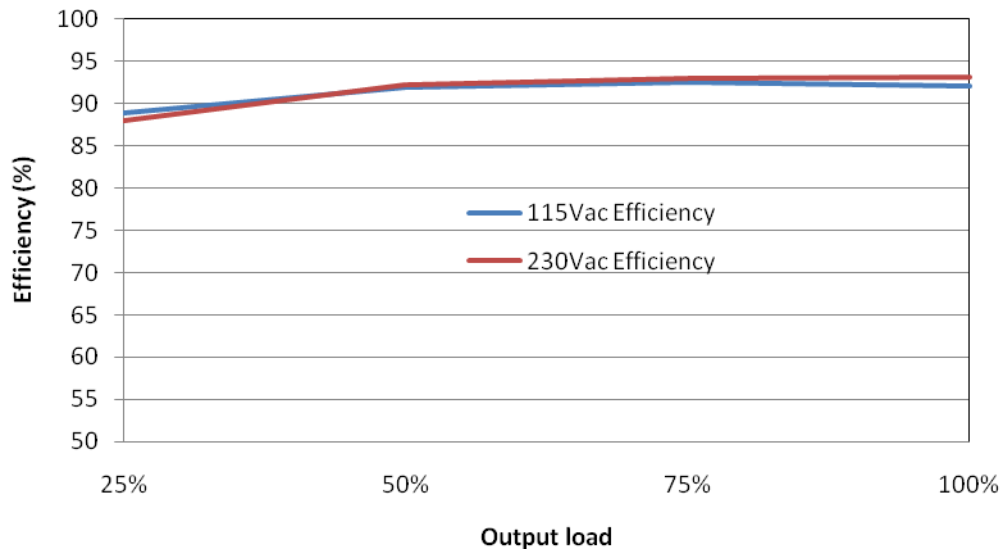

Fig.1 Efficiency versus output load

#### Output Ratings / Characteristics

Nominal Output Voltage	19Vdc
Output Voltage Tolerance	± 5%
Output Current	7.9A
Output Power	150W
Line Regulation (max)	±0.5%
Load Regulation (max)	±5%
Ripple & Noise (typ.)	109.0mV pk-pk @ Full load, Reference Fig. 2,
Start-up Time (max)	3000ms
Hold-up Time (min)	15ms @ 115Vac&230Vac
Dynamic Response (Overshoot & Undershoot O/P Voltage)	± 5% @ 50-100% load

# MDS Medical AC-DC Adapter

## 19Volt, 150Watt / MDS-150CAB19 A

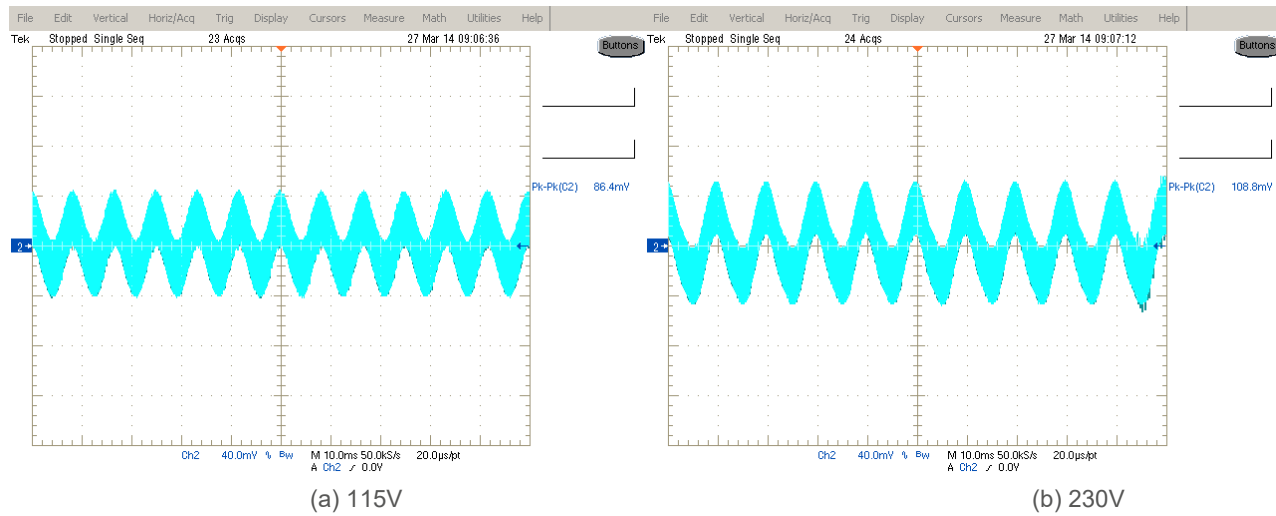
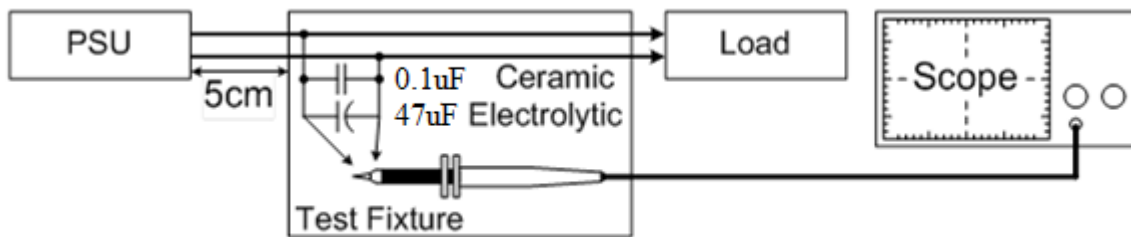

Fig. 2 Ripple & Noise example, 20MHz BW

### Ripple & Noise measurement circuit



### Mechanical

Case Chassis	Polycarbonate
Case Cover	Polycarbonate
Dimensions(W x Lx H)	65.0x 150.0x32.0 mm
Unit Weight	0.52kg (18.4 ounces)
Indicator	NA
Cooling System	NA
Terminal	Input C6 Socket
	Output 4 Pin Din

### Environment

Surrounding Air Temperature	Operating	0°C to +40°C
	Storage	-40°C to +85°C
Operating Humidity		10-95% RH (Non-Condensing)
Operating Altitude		5,000 meters
Shock Test (Non-Operating)		50G, 11ms, 3 shocks for each direction
Vibration (Operating)		5-500Hz, 2.09Grms, 20 minute for each three axis

# MDS Medical AC-DC Adapter

## 19Volt, 150Watt / MDS-150CAB19 A

### Protections

Overvoltage (max)	112%, Latch Mode or Auto-Recovery
Over load / Over current (max)	113% of rated load current, Hiccup Mode, (Non-Latching, Auto-Recovery)
Over Temperature	Hiccup Mode, (Non-Latching, Auto-Recovery)
Short Circuit	Hiccup Mode, (Non-Latching, Auto-Recovery)
Degree of Protection	IP22
Protection Against Shock	Class I

### Reliability Data

MTBF (typ.)	2103k Hours based on Telecordia SR-332
-------------	--

### Safety Standards / Directives

Medical Safety	IEC60601-1: (Ed.3,2005), EN60601-1:2006, CAN/CSA-C22.2 No. 60601-1:08, ANSI/AAMI ES60601-1: (Ed.3,2005)	
ITE Safety	IEC60950-1 (Ed.2,2005), IEC62368-1, GB4943.1-2011, GB9254-2008, GB17625.1-2003	
CE	MDD Directive 93/42/EEC	
Galvanic Isolation	Input to Output	4000 Vac
	Input to Ground	1500 Vac

# MDS Medical AC-DC Adapter

## 19Volt, 150Watt / MDS-150CAB19 A

### EMC

EMC / Emissions		EN55011 & Compliant with EN55032, FCC Title 47: Class B
Immunity to		
Voltage Flicker	IEC61000-3-3	Meet the requirement
Electrostatic Discharge	IEC61000-4-2	Level 3 Criteria A <sup>1)</sup> Air Discharge: 8kV Contact Discharge: 6kV
Radiated Field	IEC61000-4-3	Level 2 Criteria A <sup>1)</sup> 80MHz-1GHz, 3V/M with 1kHz tone / 80% modulation
Electrical Fast Transient / Burst	IEC61000-4-4	Level 3 Criteria A <sup>1)</sup> 2kV
Surge	IEC61000-4-5	Level 3 Criteria A <sup>1)</sup> Common Mode <sup>2)</sup> : 2kV Differential Mode <sup>3)</sup> : 1kV
Conducted	IEC61000-4-6	Level 2 Criteria A <sup>1)</sup> 150kHz-80MHz, 3Vrms
Power Frequency Magnetic Fields	IEC61000-4-8	Criteria A <sup>1)</sup> Magnetic field strength 3A/Meter
Voltage Dips	IEC61000-4-11	30% 10ms Criteria A ; 60% 100ms and 100% 5000ms Criteria B
Harmonic current emissions	IEC61000-3-2	Meet Class D limit

1) Criteria A: Normal performance within the specification limits  
 2) Asymmetrical: Common mode (Line to earth)  
 3) Symmetrical: Differential mode (Line to line)

### Block Diagram

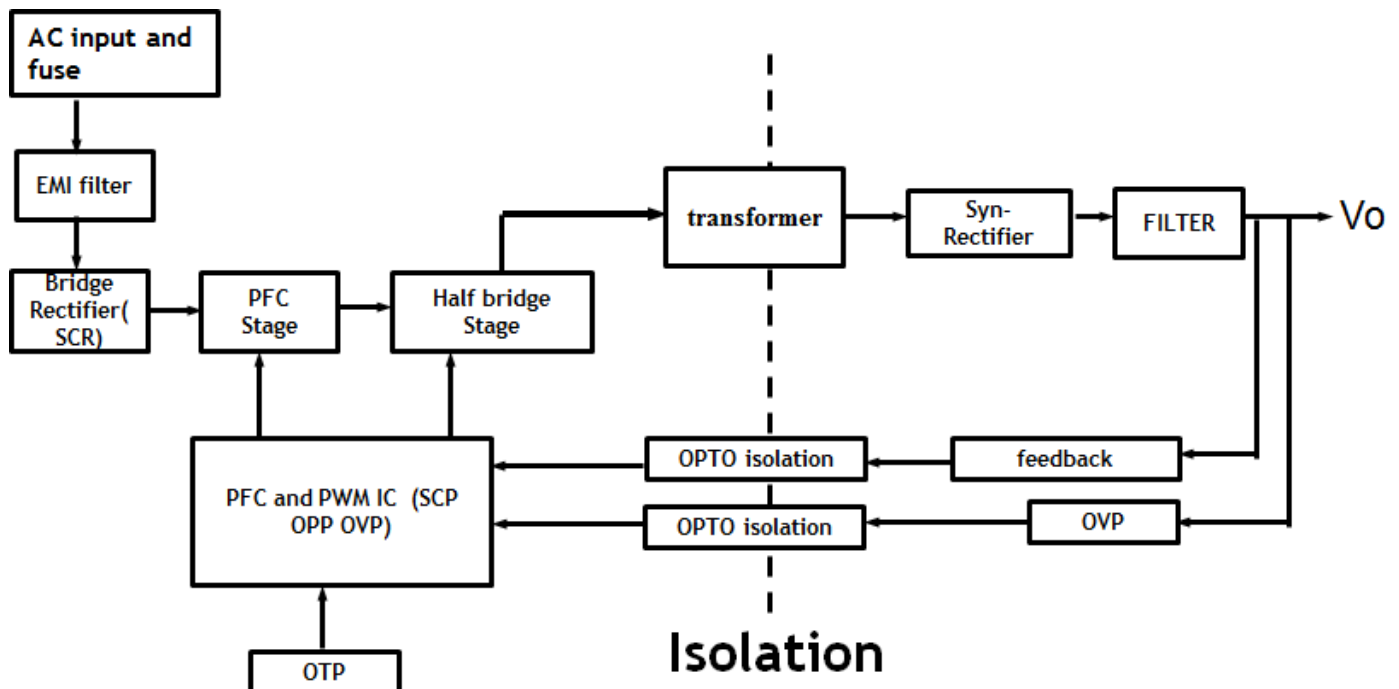

# MDS Medical AC-DC Adapter

## 19Volt, 150Watt / MDS-150CAB19 A

### Dimensions

W x L x H: 65.0x 150.0x32.0 mm

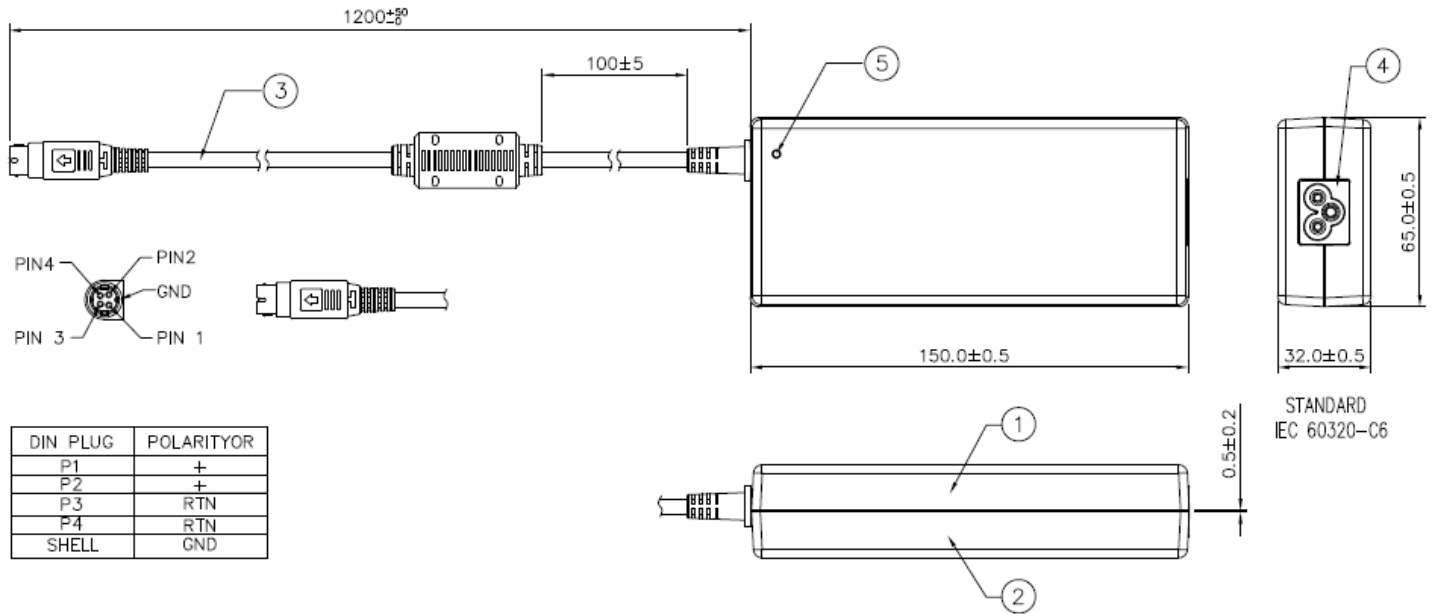

### Notes

- Dimensions are in mm

Item	Device Description
1	Cover
2	Chassis
3	Power Cord
4	Socket
5	Lens

# MDS Medical AC-DC Adapter

## 19Volt, 150Watt / MDS-150CAB19 A

### Functions

#### Start-up Time

The time required for the output voltage ( $V_o$ ) to reach 90% of its set value, after the input AC voltage is applied.

#### Rise Time

The time required for the output voltage ( $V_o$ ) to change from 10% to 90% of its steady state value.

#### Hold-up Time

Hold up time is the time when the AC input collapses and output voltage retains regulation for a certain period of time. The time required for the output to reach 95% of its set value, after the input voltage is removed.

#### ■ Graph illustrating the Start-up Time, Rise Time, and Hold-up Time

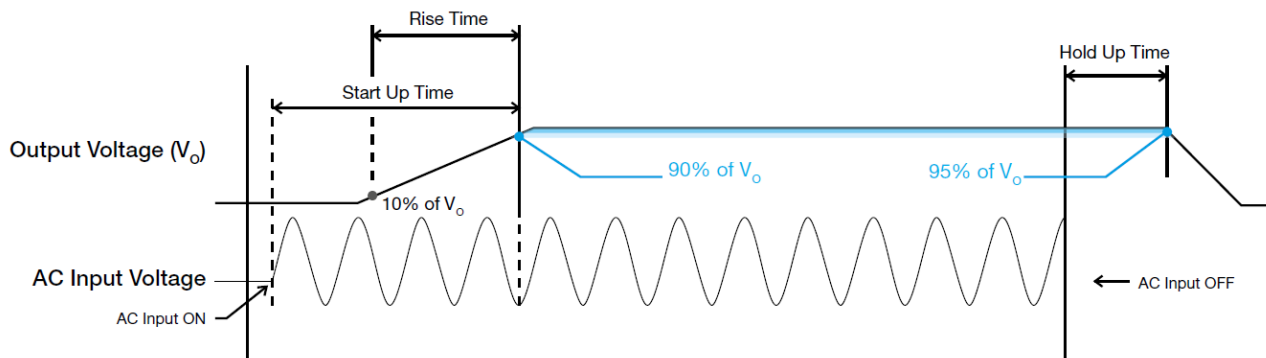

# MDS Medical AC-DC Adapter

## 19Volt, 150Watt / MDS-150CAB19 A

### Dynamic Response

The power supply output voltage will remain within  $\pm 5\%$  of its steady state value, when subjected to a dynamic load change from 50 to 100% of its rated current.

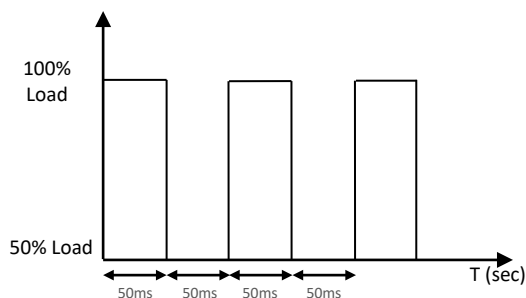

### Inrush Current

Inrush current is the input current that occurs when the input voltage is first applied. For AC input voltages, the maximum peak value of inrush current will occur during the first half cycle of the applied AC voltage. This peak value decreases exponentially during subsequent cycles of AC voltage.

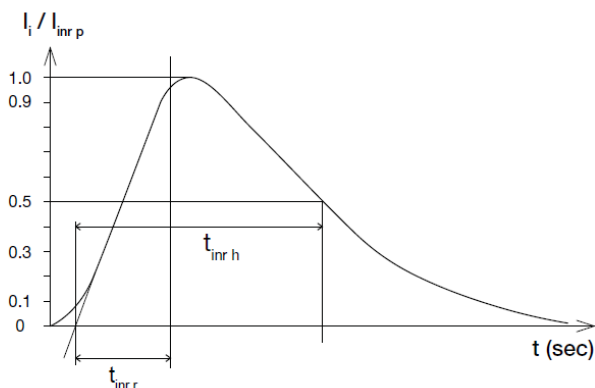

### Overvoltage Protection

The power supply's overvoltage circuit will be activated when its internal feedback circuit fails. The output voltage shall not exceed its specifications defined on Page 4 under "Protections". Power supply will latch mode, and require removal/re-application of input AC voltage in order to restart.

### Short Circuit Protection

The power supply's output OLP/OCP function also provides protection against short circuits. When a short circuit is applied, the output current will operate in "Hiccup mode", as shown in the illustration in the OLP/OCP section on this page. The power supply will return to normal operation after the short circuit is removed.

### Overload & Over current Protections

The power supply's Overload (OLP) and Over current (OCP) Protections will be activated when output current is between 110% and 130% of  $I_o$  (Max load). Upon such an occurrence,  $V_o$  will start to drop. Once the power supply has reached its maximum power limit, the protection will be activated, and the power supply will go into "Hiccup mode" (Auto-Recovery). The power supply will recover once the fault condition causing the OLP and OCP is removed and  $I_o$  is back within the specified limit.

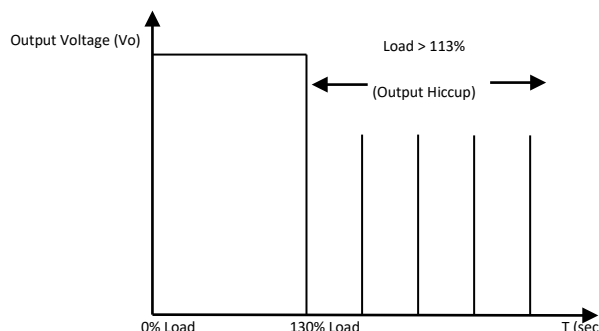

Additionally, if the  $I_o$  is  $< 130\%$  but  $> 110\%$  for a prolonged period of time (depending on the load), the Over Temperature Protection (OTP) will be activated due to high temperature on critical components. The power supply will then go into hiccup mode until the fault is removed; and, the input voltage is removed, then reapplied.

### Over Temperature Protection

As mentioned above, the power supply also has Over Temperature Protection (OTP). This is activated when the overload condition persists for an extended duration and the output current is below the overload trigger point but  $> 100\%$  load. In the event of a higher operating condition at 100% load, the power supply will run into OTP when the surrounding air temperature is higher than the operating temperature. When activated, the output voltage will go into hiccup mode until the input voltage is removed; then, reapplied, and the surrounding air temperature drops to its normal operating temperature.



# MDS Medical AC-DC Adapter

## 19Volt, 150Watt / MDS-150CAB19 A

### Certificate



Delta has been certified as meeting the requirement of ISO 13485: 2003 and EN ISO 13485:2012 for the design and manufacture of switching power supply and adaptor for medical device.



Delta is approved for the UL Total Certification Program (TCP) approved client laboratory for IEC62368-1. Delta also has participated UL Client Test Data Program (CTDP) for IEC 60601.



Energy star level V compliance

### Attention

Delta provides all information in the datasheets on an "AS IS" basis and does not offer any kind of warranty through the information for using the product. In the event of any discrepancy between the information in the catalog and datasheets, the datasheets shall prevail (please refer to [www.DeltaPSU.com](http://www.DeltaPSU.com) for the latest datasheets information). Delta shall have no liability of indemnification for any claim or action arising from any error for the provided information in the datasheets. Customer shall take its responsibility for evaluation of using the product before placing an order with Delta.

Delta reserves the right to make changes to the information described in the datasheets without notice.