



FEATURES

- Universal 85 - 277VAC or 120 - 390VDC Input voltage
- Efficiency up to 94.5%
- Operating ambient temperature range: -40°C to +85°C, full load at 60°C
- 150% peak load
- Active PFC, PF ≥ 0.98
- DC OK function
- Double-sided conformal coating, salt-spray proof, explosion-proof
- Operating altitude up to 5000m
- OVC III (design refer to EN62477, 2000m)
- OVC II
- Pollution degree 2
- 5 years warranty
- Output short circuit, over-current, over-voltage, over-temperature protection
- Safety according to ATEX, IECEx increased safety type explosion-proof certification
- Safety according to ANSI/ISA 71.04-2013 G3 anticorrosion test
- Safety according to IEC/UL62368, EN60335, EN62477, UL508



CE Report



RoHS



UL61010-1

EN62368-1

BS EN 62368-1

LIMF120-23Bxx is Mornsun explosion-proof Din-rail power supply featuring with energy saving, high performance, high reliability, high efficiency. With 150% peak load capacity is enough to support heavy loads such as DC motors or capacitive loads, up to 94.5% efficiency can greatly improve power supply reliability and service life. With good EMC performance and compliant with international standards of IEC/EN/UL/BS EN62368, UL61010, EN60335, EN62477, UL508 for EMC and safety. The power supply meets the "ec" increased safety and "nC" isolation short-circuit n-type explosion-proof certification and is suitable for explosive environment where the equipment protection level is Gc in zone 2. They are widely used in wind power industry, DCS, industrial control equipment, machine control, LED, street light control, electric power, security, 5G communication and other fields.

Selection Guide

Certification	Part No.*	Output Power (W)	Nominal Output Voltage and Current (Vo/Io)	Output Voltage Adjustable Range (V)	Efficiency at 230VAC (%) Typ.	Max. Capacitive Load (μF)
EN/UL	LIMF120-23B12	120	12V/10A	12-14	93	80000
	LIMF120-23B24		24V/5A	24-28	94	50000
	LIMF120-23B48		48V/2.5A	48-56	94.5	25000

Note: *When the output voltage rises, the total power of the product should not exceed the rated power.

Input Specifications

Item	Operating Conditions	Min.	Typ.	Max.	Unit
Input Voltage Range	Rated input (Certified voltage)	100	--	240	VAC
	AC input	85	--	277	
	DC input	120	--	390	VDC
Maximum Input Voltage	Lasts for 2h without damage	--	--	305	VAC
Input Voltage Frequency		47	--	63	Hz
Input Current	115VAC	--	--	1.5	A

Inrush Current	230VAC	Cold start	--	--	0.75	
	115VAC		--	15	--	
	230VAC		--	30	--	
Power Factor	115VAC	Room temperature, full load	0.98	--	--	--
	230VAC		0.95	--	--	
Start-up Delay Time	115VAC/230VAC, rated load		--	--	3000	ms
Input Fuse	Built-in fuse		--	8	--	A
Hot Plug	Unavailable					

Output Specifications

Item	Operating Conditions		Min.	Typ.	Max.	Unit
Output Voltage Accuracy	Full load range		--	±1.0	--	%
Line Regulation	Rated load		--	±0.5	--	
Load Regulation	0% - 100% load		--	±1.0	--	
Minimum Load			0	--	--	
Stand-by Power Consumption			--	--	5	W
Power Consumption*	230VAC, rated load		--	8	--	
Ripple & Noise*	20MHz bandwidth (peak-to-peak value)		--	--	100	mV
Hold-up Time			--	35	--	ms
DC OK Signal	Resistive load		30VDC/1A Max.			
Over-current Protection*	115VAC/230VAC	Room temperature	110	150	--	%
		High temperature, low temperature	105	--	--	
Short Circuit Protection*			Hiccup mode, constant current works 1s (Typ.), turn off 10s, continuous, self-recover			
Over-voltage Protection	12V		≤18VDC (Hiccup, self-recover)			
	24V		≤35VDC (Hiccup, self-recover)			
	48V		≤60VDC (Hiccup, self-recover)			
Over-temperature Protection*	230VAC, rated load	Over-temperature protection start	--	--	90	°C
		Over-temperature protection release	60	--	--	

- Note: 1. *The "Tip and barrel method" is used for ripple and noise test, output parallel 47uF electrolytic capacitor and 0.1uF ceramic capacitor, please refer to Enclosed Switching Power Supply Application Notes for specific information;
 2. *Over-temperature protection: Put the product into a high temperature box. After the ambient temperature stabilizes, increase the temperature slightly (3°C to 5°C), and the load remains unchanged. After the product reaches thermal equilibrium, increase the temperature until the product triggers over-temperature protection;
 3. *Power consumption curve, over-current protection mode and short circuit protection mode see product characteristic curve.

General Specifications

Item	Operating Conditions		Min.	Typ.	Max.	Unit
Isolation Test*	Input - ⊕	Electric strength test for 1min., leakage current <10mA (Isolation Test for ⊕ need to remove the screw at the mark shall ⊕ *)	2500	--	--	VAC
	Input - output		4000	--	--	
	Output - ⊕		500	--	--	
	DC OK - output		500	--	--	
Insulation Resistance	Input - ⊕	Ambient temperature: 25 ± 5°C	500	--	--	MΩ
	Input - output	Relative humidity: < 95%RH, no condensation	500	--	--	
	Output - ⊕	Test voltage: 500VDC	500	--	--	
Operating Temperature			-40	--	+85	°C
Storage Temperature			-40	--	+85	
Operating Humidity			10	--	95	%RH
Storage Humidity	Non-condensing		20	--	90	

Switching Frequency*	PFC	40	--	130	kHz	
	DC-DC	50	--	130		
	Auxiliary source	--	65	--		
Power Derating	Operating temperature derating	-40°C to -25°C	3.34	--	--	% / °C
		+60°C to +70°C	3	--	--	
		+70°C to +85°C	3.34	--	--	
	Input voltage derating	85VAC - 100VAC	1	--	--	% / VAC
Leakage Current	240VAC	Touch current	<0.88mA			
Safety Standard	UL61010-1 safety approved & EN62368-1, BS EN62368-1(Report) Design refer to IEC/UL62368-1, UL508, IEC60079-0, IEC60079-7, IEC60079-15, EN60335-1, EN62477-1, ANSI/ISA 71.04-2013					
Safety Class	CLASS I					
MTBF	MIL-HDBK-217F@25°C		>702,000h			
	MIL-HDBK-217F@40°C		>524,000h			
Warranty	Ambient temperature: <40°C		5 years			
High and Low Voltage Crossing	Test with Mornsun P/N: LUPS20-24F-N		NB/T 31111-2017			
<p>Note: 1. *The gas discharge tube built into the device effectively protects the power supply against damage by asymmetric disturbance variables (eg EN 61000-4-5). Each power supply continuous withstand voltage test will cause extremely high load to the power supply. Therefore, unnecessary loading or damage to the power supply due to excessive test voltage should be avoided. If necessary, disconnect the gas discharge tube built into the device to use a higher test voltage. After successful completion of the test, reconnect the gas discharge tube. Please refer to the "LIMF120-23Bxx Installation and Application Manual" for specific operation methods;</p> <p>2. *The power supply has three converters with three different switching frequencies. Auxiliary source frequency is nearly constant, other switching frequencies depend on input voltage and load.</p>						

Environmental Characteristics

Item	Operating Conditions	Standard
High and Low Temperature Working	+85°C, -40°C	GB2423.1, IEC60068-2-1
Sinusoidal Vibration	10 - 500Hz, 2g, three directions of X, Y, Z axis	GB2423.10, IEC60068-2-6
Salt Mist	+35°C, 5%NaCl, 48h	GB2423.17, IEC60068-2-11
Alternating Hot and Humid	+25°C, 95%RH - +60°C, 95%RH	GB2423.4, IEC60068-2-30
Low Temperature Storage	-40°C	GB2423.1, IEC60068-2-1
High Temperature Storage	+85°C	GB2423.2, IEC60068-2-2
High Temperature Aging	+60°C	GB2423.2, IEC60068-2-2
Normal Temperature Aging	+25°C	GB2423.1, IEC60068-2-1
Temperature Shock	-40°C to +85°C	GB2423.22, IEC60068-2-14
Temperature Cycle	-25°C to +60°C	GB2423.22, IEC60068-2-14
Hot and Humid	+85°C, 85%RH	GB2423.50, IEC60068-2-67
High Temperature Elevation	+60°C, 54KPa	GB2423.26, IEC60068-2-41
Low Temperature Elevation	-25°C, 54KPa	GB2423.25, IEC60068-2-40
Constant Humid and Hot	+40°C, 95%RH	GB2423.3, IEC60068-2-78
Random Vibration	5 - 10Hz, ASD 0.3 - 10g ² /Hz, three directions of X, Y, Z axis	GB/T 4798.2-2008, IEC60721-3-2
Sinusoidal Vibration Response	10 - 150Hz, 1g, three directions of X, Y, Z axis	GB/T 11287-2000, IEC60255-21-1
Sinusoidal Vibration Endurance Test		
Sinusoidal Impulse Response	15g, pulse duration 11ms, three times in each direction of X, Y, Z axis	GB/T 114537-1993, IEC60255-21-2
Sinusoidal Impact Endurance Test		
Packaging Drop	1m, one corner, three edges and six sides	GB2423.8, IEC68-2-32

Mechanical Specifications

Case Material	Metal (AL5052, SUS304)
Dimensions	124.00mm x 121.00mm x 34.00mm
Weight	540g (Typ.)
Cooling Method	Free air convection

Electromagnetic Compatibility (EMC)

Emissions	CE (Input port)	CISPR32 EN55032	150K - 30MHz	CLASS B	
	CE (Output port)	CISPR32 EN55032	150K - 30MHz	CLASS A +20dB	
	RE	CISPR32 EN55032	30MHz - 2GHz	CLASS B	
	Harmonic current	IEC/EN61000-3-2		CLASS A and CLASS D	
	Voltage flicker	EN61000-3-3			
Immunity	ESD	IEC/EN61000-4-2	Contact ±8KV/Air ±15KV	perf. Criteria A	
	RS	IEC/EN61000-4-3	20V/m		
	EFT (Input port)	IEC/EN61000-4-4	±4KV		
	EFT (Output port)	IEC/EN61000-4-4	±2KV		
	Surge (Input port)	IEC/EN61000-4-5	line to line ±3KV/line to ground ±6KV		
	Surge (Output port)	IEC/EN61000-4-5	line to line ±1KV/line to ground ±2KV		
	MS	IEC/EN61000-4-8	30A/m		
	AC power port harmonics				
	Harmonic and network signal	IEC61000-4-13	CLASS 3		
	Low frequency immunity				
	CS	IEC/EN61000-4-6	0.15 - 80MHz 20Vr.m.s		
	Voltage dips	IEC/EN61000-4-11	0% of 100Vac, 0Vac, 20ms		perf. Criteria A
			40% of 100Vac, 40Vac, 200ms		perf. Criteria C
70% of 100Vac, 70Vac, 500ms			perf. Criteria A		
0% of 200Vac, 0Vac, 20ms			perf. Criteria A		
40% of 200Vac, 80Vac, 200ms			perf. Criteria A		
70% of 200Vac, 140Vac, 500ms			perf. Criteria A		
Voltage interruption	IEC/EN61000-4-11	0% of 200Vac, 0Vac, 5000ms	perf. Criteria C		

Note: *perf. Criteria:

A: The equipment shall continue to operate as intended without operator intervention;

B: After the test, the equipment shall continue to operate as intended without operator intervention;

C: Loss of function is allowed, provided the function is self-recoverable, or can be restored by the operation of the controls by the user in accordance with the manufacturer's instructions.

Product Characteristic Curve

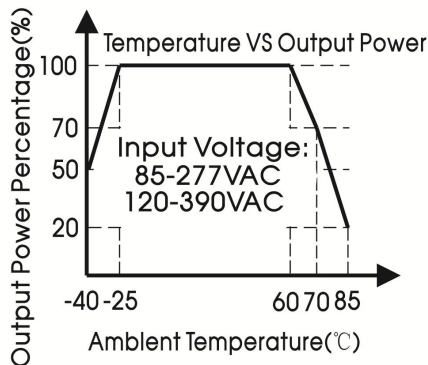

Figure 1

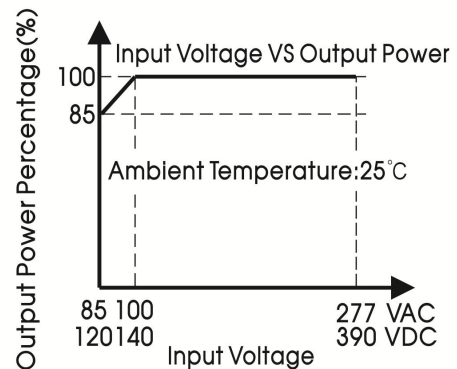

Figure 2

Output voltage VS Output current curve (Typ.)

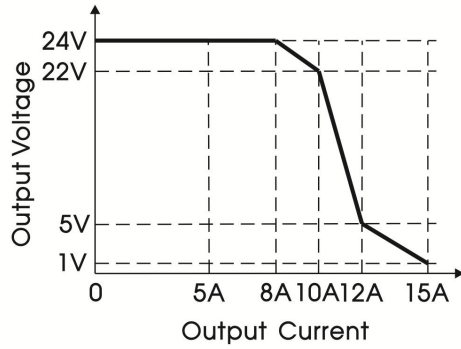

Figure 3

DC OK behavior curve (Typ.)

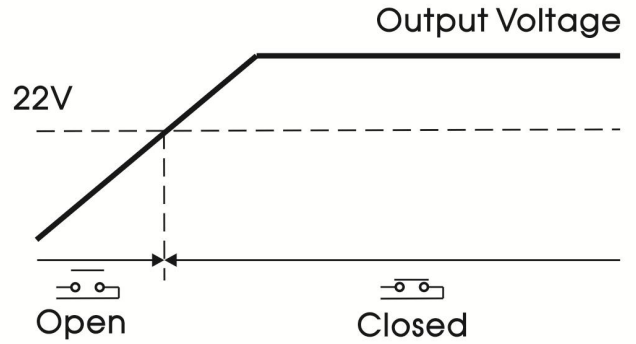

Figure 4

Over-current protection curve (Typ.)

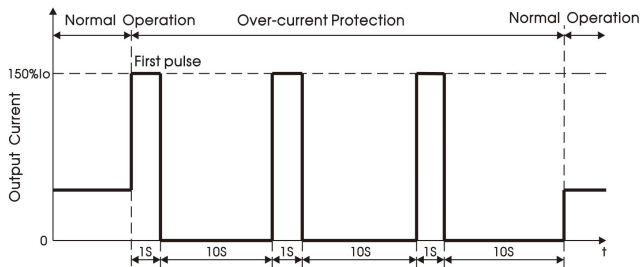

Figure 5

Short circuit protection curve (Typ.)

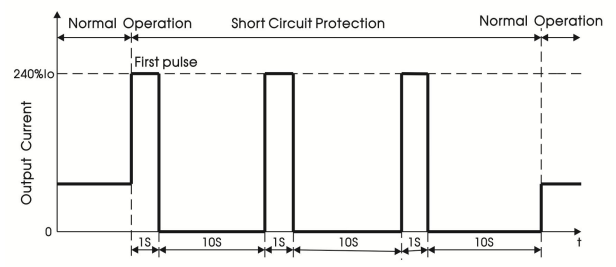

Figure 6

PF Vs Input Voltage (Full Load)

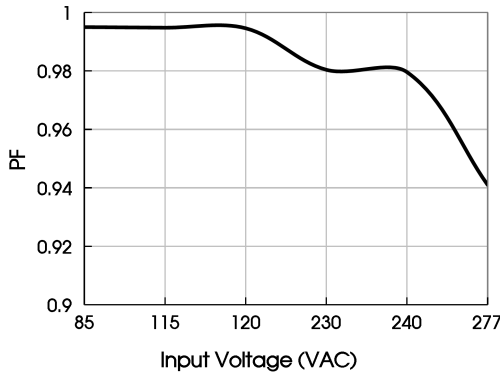

Figure 7

PF Vs Output Load (Vin=230VAC)

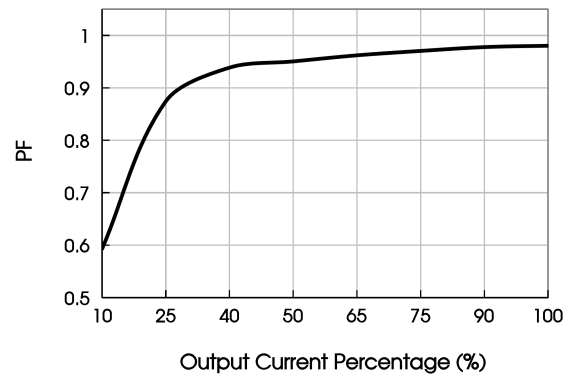

Figure 8

Loss Vs Input Voltage (Full Load)

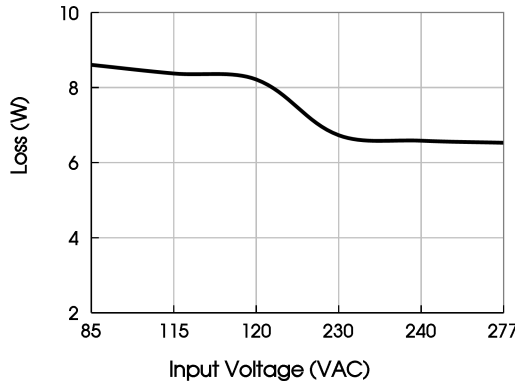

Figure 9

Loss Vs Output Load (Vin=230VAC)

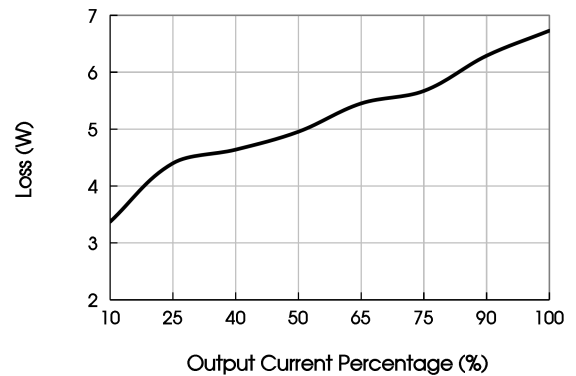

Figure 10

- Note: 1.All curves are for 24V output, measured at input 230VAC, 50Hz, output I_o, ambient temperature 25°C, unless otherwise stated;
 2. Figure 3 shows that the product will enter the overload state when the rated output current increases to 100%-150%I_o (TYP.), and enter the overcurrent protection when the current > 150%I_o (TYP.), and the output voltage will decrease with the increase of the output current. When the output current increases to a certain value, the product will enter the constant current mode;
 3. With an AC input voltage between 85-100VAC and a DC input between 120-140VDC the output power must be derated as per the temperature derating curves;
 4. This product is suitable for applications using natural air cooling; for applications in closed environment please consult Mornsun FAE.

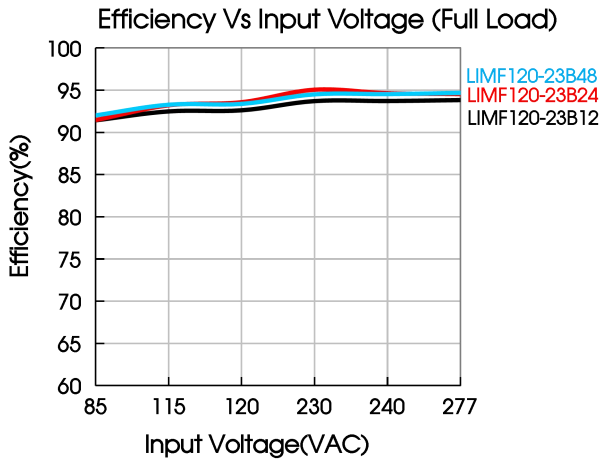

Figure 11

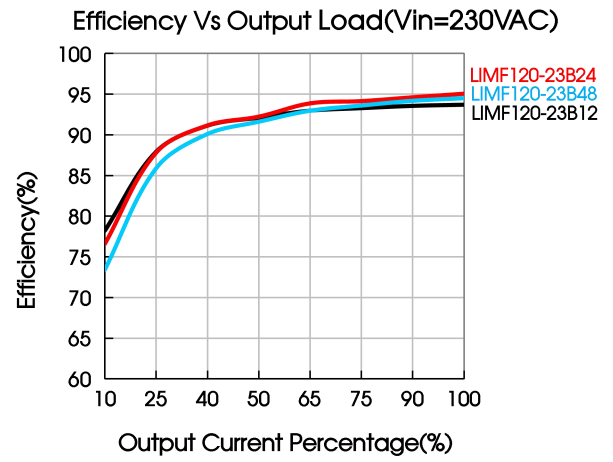
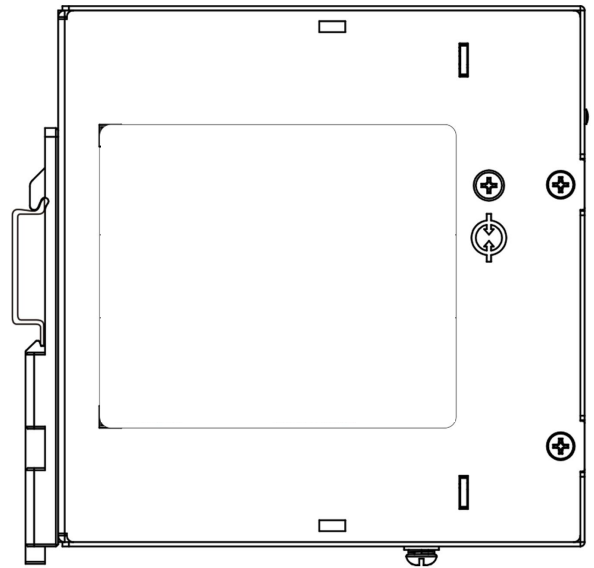
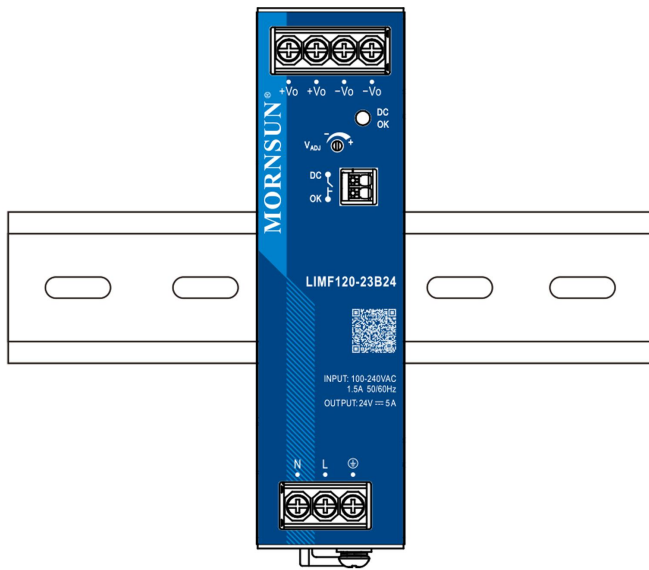
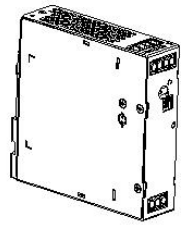

Figure 12

Installation Diagram



Bill Of Material		
1	Product	1 PCS
2	Phillips screwdriver Slotted screwdriver	1 PCS
3	TS35/7.5 or TS35/15	1 PCS
4	24-10AWG wires	/PCS
	All above is only for reference, the actual wiring diameter and locking torque refer to the appearance size diagram	



Product

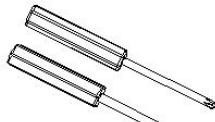

Phillips screwdriver
Slotted screwdriver
Diameter of the cutting
tools: 3mm

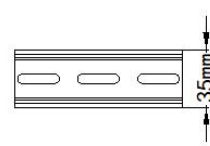

TS35/7.5 or TS35/15

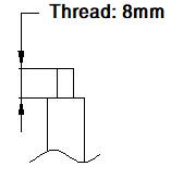

24-10AWG wires

Installation steps ①-②

① Put the product buckle down into the TS35 rail.

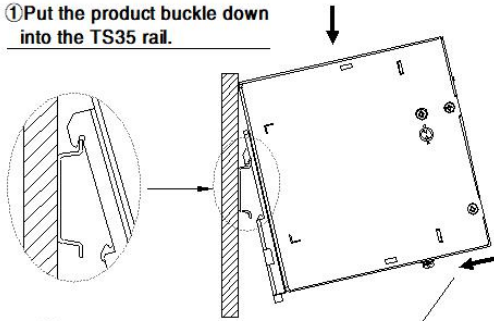

② Push the product perpendicular to the TS35 rail until hear the sound of the clip snapping into the rail.

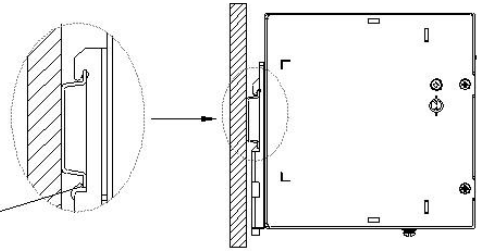

Disassembly steps ③-④

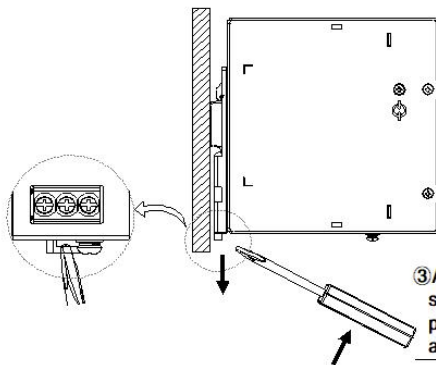

③ After inserting a Slotted screwdriver into the square groove at the bottom of the buckle, push the sliding part of the buckle downward according to the direction shown.

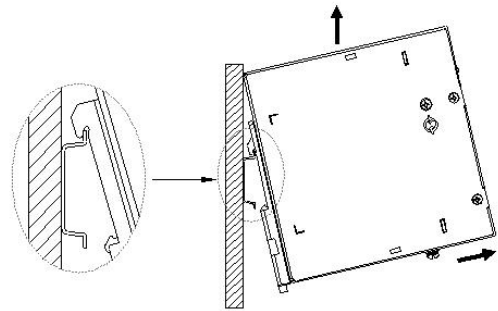

④ Push the bottom of the product outwards and take it out upwards.

Connecting/Disconnecting Steps ⑤-⑥

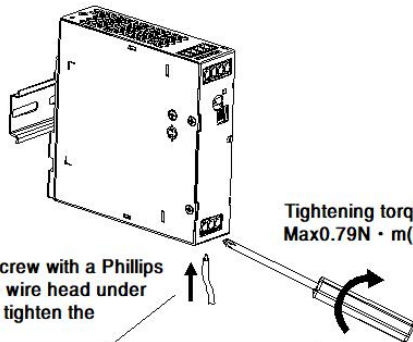

⑤ Loosen the terminal screw with a Phillips screwdriver, insert the wire head under the terminal, and then tighten the terminal screw.

Tightening torque:
Max0.79N · m(Reference);

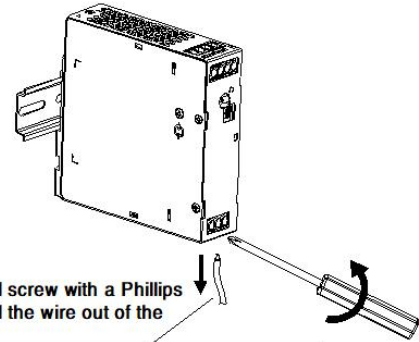

⑥ Loosen the terminal screw with a Phillips screwdriver and pull the wire out of the terminal hole.

Note: Keep the following installation clearances: 20mm on the top, 20mm on the bottom, 5mm on the left and right sides are recommended when the device is loaded permanently with more than 50% of the rated power. Increase this clearance to 15mm in case the adjacent device is a heat source (e.g. another power supply).

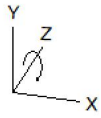

Rotate the installation position
(0° Z-Axis)

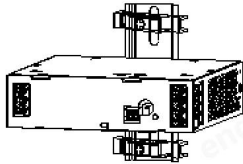
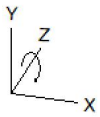
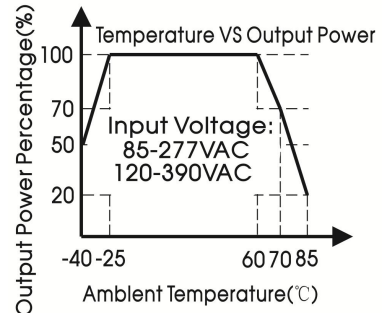

Rotate the installation position
(90° Z-Axis)

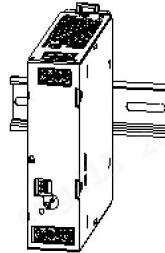
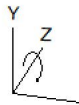
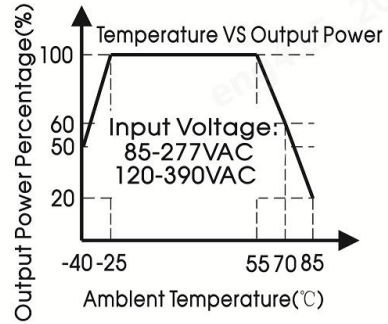

Rotate the installation position
(180° Z-Axis)

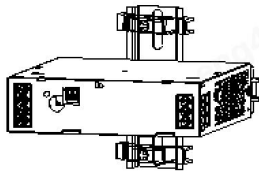
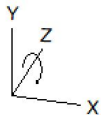
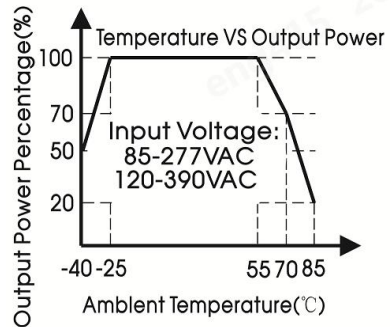

Rotate the installation position
(270° Z-Axis)

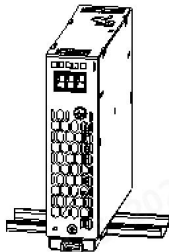
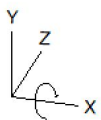
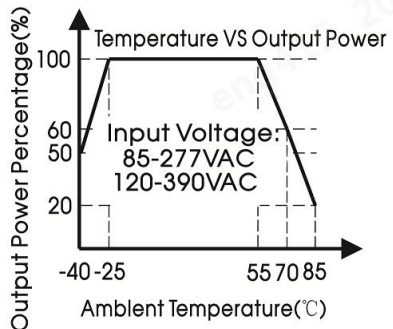

Rotate the installation position
(270° X-Axis)

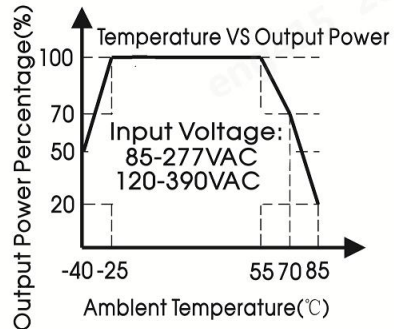

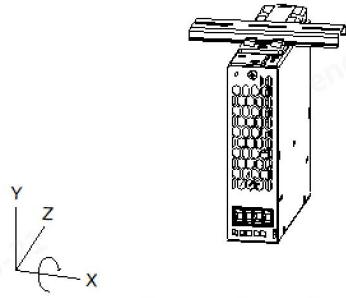

Rotate the installation position
(90° X-Axis)

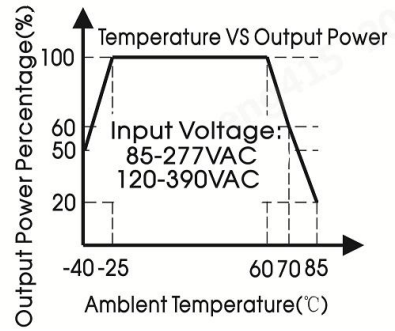

Dimensions and Recommended Layout

THIRD ANGLE PROJECTION

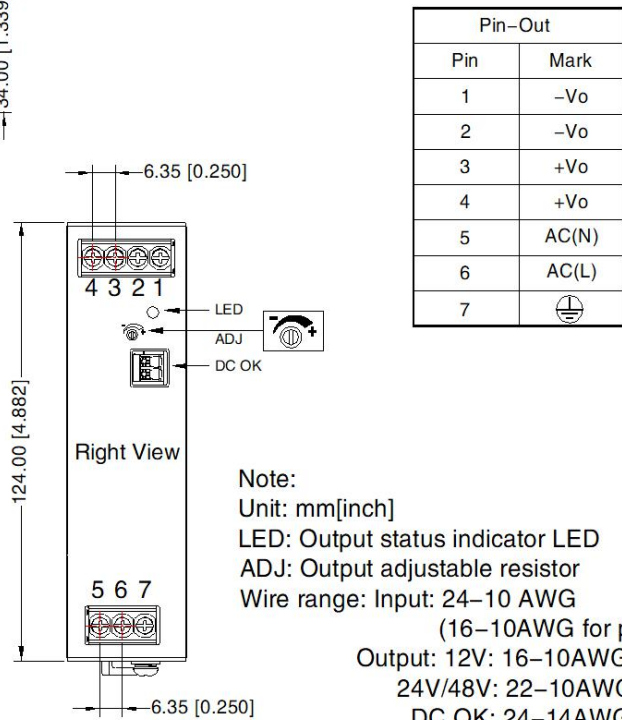
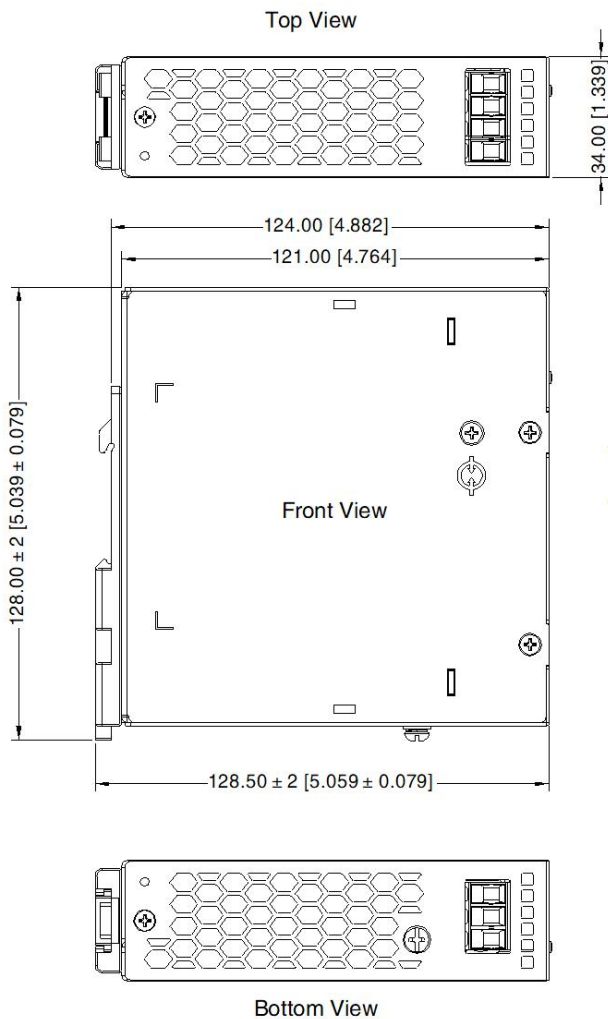

Pin-Out	
Pin	Mark
1	-Vo
2	-Vo
3	+Vo
4	+Vo
5	AC(N)
6	AC(L)
7	

Note:

Unit: mm[inch]

LED: Output status indicator LED

ADJ: Output adjustable resistor

Wire range: Input: 24-10 AWG

(16-10AWG for pin7)

Output: 12V: 16-10AWG

24V/48V: 22-10AWG

DC OK: 24-14AWG

Tightening torque: Max 0.79 N·m

Mounting rail: TS35, rail needs to connect safety ground

General tolerances: ± 1.00[± 0.039]



WARNING Risk of electrical shock, fire, personal injury or death:

AVERTISSEMENT AVERTISSEMENT Risque de choc électrique, d'incendie, de blessures corporelles ou de décès :

1. Do not use the power supply without proper grounding (Protective Earth). Use the terminal on the input block for earth connection and not one of the screws on the housing;
N'utilisez pas l'alimentation électrique sans mise à la terre appropriée (Terre protectrice). Utilisez le terminal sur le bloc d'entrée pour la connexion terrestre et non pas une des vis sur le boîtier;
2. Turn power off before working on the device, protect against inadvertent re-powering;
Éteignez l'alimentation avant de travailler sur l'appareil, protégez-vous contre la réenergisation accidentelle;
3. Make sure that the wiring is correct by following all local and national codes;
Assurez-vous que le câblage est correct en suivant tous les codes locaux et nationaux;
4. Do not modify or repair the unit;
Ne modifiez pas ou ne réparez pas l'appareil;
5. Do not open the unit as high voltages are present inside;
Ne modifiez pas ou ne réparez pas l'appareil;
6. Use caution to prevent any foreign objects from entering the housing;
Faire preuve de prudence pour empêcher les objets étrangers d'entrer dans le logement;
7. Do not use in wet locations or in areas where moisture or condensation can be expected;
Faire preuve de prudence pour empêcher les objets étrangers d'entrer dans le logement;
8. Do not touch during power-on, and immediately after power-off, hot surfaces may cause burns; 
Ne touchez pas pendant l'alimentation et, immédiatement après l'alimentation, les surfaces chaudes peuvent causer des brûlures.
9. For ambient temperature $\leq 60^{\circ}\text{C}$, use $\geq 90^{\circ}\text{C}$ - copper wire only; for ambient temperature $>60^{\circ}\text{C}$ to 85°C , use $\geq 105^{\circ}\text{C}$ - copper wire only; use only wires with a minimum dielectric strength of 300V (input) and 60V (output);
Température ambiante $\leq 60^{\circ}\text{C}$, utiliser $\geq 90^{\circ}\text{C}$ - seulement fils de cuivre; Température ambiante $>60^{\circ}\text{C}$ et 85°C , utiliser $\geq 105^{\circ}\text{C}$ - seulement fils de cuivre; Uniquement pour l'utilisation de fils de cuivre d'une résistance d'isolation minimale de 300V (d'entrée) et 60V (de sortie).

Note:

1. For additional information on Product Packaging please refer to www.mornsun-power.com. Packaging bag number: 58220319;
2. Unless otherwise specified, parameters in this datasheet were measured under the conditions of $T_a=25^{\circ}\text{C}$, humidity $<75\%$ RH with nominal input voltage and rated output load;
3. The room temperature derating of $5^{\circ}\text{C}/1000\text{m}$ is needed for operating altitude greater than 2000m;
4. All index testing methods in this datasheet are based on our company corporate standards;
5. In order to improve the efficiency at high input voltage, there will be audible noise generated, but it does not affect product performance and reliability;
6. We can provide product customization service, please contact our technicians directly for specific information;
7. Products are related to laws and regulations: see "Features" and "EMC";
8. The out case needs to be connected to PE (\oplus) of system when the terminal equipment in operating;
9. The output voltage can be adjusted by the ADJ, clockwise to increase;
10. Our products shall be classified according to ISO14001 and related environmental laws and regulations, and shall be handled by qualified units.

Matlog

4 avenue du Vieil Etang | Espace Ouest - Hall A | 78180 Montigny le Bretonneux
+33 1 80 97 92 70 | contact@matlog.com | www.matlog.fr