

High-end Type



**FEATURES**

- Universal 85 - 277VAC or 120 - 390VDC Input voltage
- Operating ambient temperature range: -40°C to +85°C , full load at 60°C
- High efficiency, high reliability
- Transient peak current function: 6 times rated current for 15ms
- Up to 150% (PN) dynamic power for 5s
- Continuous static power margin of up to 125% (PN)
- Support 5+1 bus high precision parallel current sharing
- Active PFC, PF>0.98
- Support DC OK, AC OK, remote control function
- Support ModBus communication protocol
- Double-sided conformal coating, salt-spray proof, explosion-proof
- Operating altitude up to 5000m
- OVC III (design refer to EN62477, 2000m)
- OVC II
- Pollution degree 2
- 5 years warranty
- Output short circuit, over-current, over-voltage, over-temperature protection, input under voltage protection
- Safety according to ATEX, IECEx increased safety type explosion-proof certification
- Meets ANSI/ISA 71.04-2013 G3
- Safety according to IEC/UL62368, GB4943, IEC/EN61010, EN61558, EN62477, IEC60079, GB3836, NB/T31017



UL61010-1



EN62368-1



BS EN 62368-1



*LIHF480-23Bxx series is Mornsun explosion-proof Din-rail power supply featuring with energy saving, high performance, high reliability, high efficiency. With 150% peak load capacity is enough to support heavy loads such as DC motors or capacitive loads, up to 95% efficiency can greatly improve power supply reliability and service life. With good EMC performance and compliant with international standards of IEC/EN/UL/BS EN62368, GB4943, IEC/EN/UL61010, EN61558, EN62477, IEC60079, GB3836, NB/T31017 for EMC and safety. The power supply meets the "ec" increased safety and "nC" isolation short-circuit n-type explosion-proof certification and is suitable for explosive environment where the equipment protection level is Gc in zone 2. It is widely used in wind power industry, ships, DCS, industrial control equipment, imachine control, instrumentation, LED, power, security, 5G communication, new energy and other industries.*

**Selection Guide**

Certification	Part No.	Output Power (W)*	Nominal Output Voltage and Current (Vo/Io)	Output Voltage Adjustable Range (V)	Efficiency at 230VAC (%) Typ.	Max. Capacitive Load (μF)
EN/UL	LIHF480-23B24	480	24V/20A	24-28	94.5	50000
	LIHF480-23B48		48V/10A	48-55	95	25000

Note: \*When the output voltage rises, the total power of the product should not exceed the rated power.



### Input Specifications

Item	Operating Conditions	Min.	Typ.	Max.	Unit	
Input Voltage Range	Rated input (Certified voltage)	100	--	240	VAC	
	AC input	85	--	277		
	DC input	120	--	390	VDC	
Maximum Input Voltage	Lasts for 2h without damage	--	--	305	VAC	
Input Voltage Frequency		47	--	63	Hz	
Input Switching Voltage		65	--	80	VAC	
Input Turn-off Voltage		55	--	70		
Input Current	115VAC	--	--	6	A	
	230VAC	--	--	3		
Inrush Current	115VAC	Cold start	--	10		--
	230VAC		--	15		
Power Factor	115VAC	0.98	--	--	--	
	230VAC	0.95	--	--		
THD	115VAC, rated load	--	3.5	--	%	
Start-up Delay Time	115VAC/230VAC, rated load	--	--	2000	ms	
Input Fuse	Built-in fuse	--	10	--	A	
Hot Plug		Unavailable				

### Output Specifications

Item	Operating Conditions	Min.	Typ.	Max.	Unit	
Output Voltage Accuracy	Full load range	--	±1.0	--	%	
Line Regulation	Rated load	--	±0.25	--		
Load Regulation	0% - 100% load	--	±0.5	--		
Power Consumption*	230VAC, rated load	24V	--	27.8	W	
		48V	--	25.2		
Ripple & Noise*	20MHz bandwidth, peak-to-peak value	24V	--	80	mV	
		48V	--	180		
Hold-up Time	115VAC/230VAC	22	--	--	ms	
DC OK Signal	Resistive load	30VDC/1A Max.				
Short Circuit Protection		Hiccup mode, constant current operation(constant current time adapts with different load conditions), output off for 5s, long-term short-circuit protection, self-recover				
Static power	115VAC/230VAC	125%Io (typ.), work for a long time at room temperature				
Dynamic power		150% Io working 5s (min.), the off time adapts with different load conditions, long-term protection, self-recover				
Transient Peak Current Function		600% Io working 15ms 3 times (typ.), long-term short-circuit protection, self-recover				
Over-voltage Protection	24V	≤35VDC (Output-off or clamping, self-recover)				
	48V	≤60VDC (Output-off or clamping, self-recover)				
Over-temperature Protection*	230VAC, rated load, self-recover	Over-temperature protection start	--	--	100	°C
		Over-temperature protection release	60	--	--	

- Note: 1. \*The "Tip and barrel method" is used for ripple and noise test, output parallel 47uF electrolytic capacitor and 0.1uF ceramic capacitor, please refer to Enclosed Switching Power Supply Application Notes for specific information;  
 2. \*Over-temperature protection: Put the product into a high temperature box. After the ambient temperature stabilizes, increase the temperature slightly (3°C to 5°C), and the load remains unchanged. After the product reaches thermal equilibrium, increase the temperature until the product triggers over-temperature protection;  
 3. \*Power consumption curve, over-current protection mode and short circuit protection mode see product characteristic curve.

## General Specifications

Item	Operating Conditions		Min.	Typ.	Max.	Unit
Isolation Test*	Input - ⊕	Electric strength test for 1min., leakage current <5mA (Isolation Test for ⊕ need to remove the screw at the mark shall ⊕ *)	2500	--	--	VAC
	Input - output		4000	--	--	
	Output - ⊕		500	--	--	
Insulation Resistance	Input - ⊕	Environment temperature: 25±5℃	500	--	--	MΩ
	Input - output	Relative humidity: < 95%, non-condensing		--	--	
	Output - ⊕	Test voltage: 500VDC		--	--	
Operating Temperature			-40	--	+85	℃
Storage Temperature			-40	--	+85	
Operating Humidity	Non-condensing		10	--	95	%RH
Storage Humidity			20	--	90	
Switching Frequency*	PFC		60	--	70	kHz
	DC-DC		40	--	130	
Power Derating	Operating temperature derating @AC input	-40℃ to -30℃	2	--	--	% / ℃
		+60℃ to +75℃	2.5	--	--	
		+75℃ to +85℃ 25CFM	2.25	--	--	
	Operating temperature derating @DC input	-40℃ to -30℃	2	--	--	
		+60℃ to +75℃	2.5	--	--	
		+75℃ to +85℃ 25CFM	2.25	--	--	
Input voltage derating	85VAC - 100VAC		1	--	--	% / VAC
	120VDC - 140VDC		1	--	--	% / VDC
Leakage Current	240VAC	Touch current	<0.5mA			
Safety Standard			UL61010-1 safety approved & EN62368-1, BS EN62368-1(Report) Design refer to IEC/UL62368-1, IEC/EN61010-1, GB4943.1, EN61558-1, EN62477-1, IEC60079-0, IEC60079-7, IEC60079-15, GB3836.1, NB/T31017, ANSI/ISA 71.04-2013			
Safety Class			CLASS I			
MTBF	MIL-HDBK-217F@25℃		> 702,000h			
	MIL-HDBK-217F@40℃		> 524,000h			
OVC			III			
Warranty	Ambient temperature: <40℃		5 years			
High and Low Voltage Crossing	Test with Mornsun P/N: LUPS20-24F-N-UNT		NB/T 31111-2017			
<p>Note: 1. * ①Remove the screw at the mark ⊕ when the product is subjected to withstand voltage test; ② The gas discharge tube built into the device effectively protects the power supply against damage by asymmetric disturbance variables (eg EN 61000-4-5). Each power supply continuous withstand voltage test will cause extremely high load to the power supply. Therefore, unnecessary loading or damage to the power supply due to excessive test voltage should be avoided. If necessary, disconnect the gas discharge tube built into the device to use a higher test voltage. After successful completion of the test, reconnect the gas discharge tube. Please refer to the "LIHF480-23Bxx series power supply application manual" for specific operation methods;</p> <p>2. * The power supply has two converters with two different switching frequencies, Intermittent operation mode will be entered in light load or no load.</p>						

## Functional Specifications

Item	Operating Conditions		Min.	Typ.	Max.	Unit
Remote Control	Voltage between	Power on	0	--	0.8	VDC
	ON/OFF and SGND	Power off	4	--	20	
DC OK Relay	Operation voltage	24V	--	21.6	--	V
		48V	--	43.2	--	
	Release voltage	24V	--	19.2	--	

		48V	--	38.4	--	
AC OK Signal	Input voltage 85 - 305VAC		3	--	5	VDC
Current Sharing Accuracy	When multiple units are connected in parallel, the sub-modules shunt more than 50% of the rated load of a single power supply		--	±5	--	%
LED Signal	Main output status indicator	Normal output	LED ON			
		200%Io > Load > 125%Io	Green light flashing			
		Power off (No AC power), under-voltage protection, remote off, short circuit/over-current protection, output voltage backflow	LED OFF			
RS485-A, RS485-B	Based on ModBus communication protocol		RS485 communication			

Note:1.\* Please refer to LIHF480-23Bxx Series Power Supply Application Manual for related function control logic and usage instructions;  
2.\* When multiple units work with current sharing, the output voltage deviation of each power supply working alone shall not exceed 100mV.

### Environmental Characteristics

Item	Operating Conditions	Standard
High and Low Temperature Working	+85℃, -40℃	GB2423.1, IEC60068-2-1
Sinusoidal Vibration	10 - 500Hz, 2g, three directions of X, Y, Z axis	GB2423.10, IEC60068-2-6
Salt Mist	+35℃, 5%NaCl, 48h	GB2423.17, IEC60068-2-11
Alternating Hot and Humid	+25℃, 95%RH - +60℃, 95%RH	GB2423.4, IEC60068-2-30
Low Temperature Storage	-40℃	GB2423.1, IEC60068-2-1
High Temperature Storage	+85℃	GB2423.2, IEC60068-2-2
High Temperature Aging	+60℃	GB2423.2, IEC60068-2-2
Normal Temperature Aging	+25℃	GB2423.1, IEC60068-2-1
Temperature Shock	-40℃ to +85℃	GB2423.22, IEC60068-2-14
Temperature Cycle	-25℃ to +60℃	GB2423.22, IEC60068-2-14
Hot and Humid	+85℃, 85%RH	GB2423.50, IEC60068-2-67
High Temperature Elevation	+60℃, 54KPa	GB2423.26, IEC60068-2-41
Low Temperature Elevation	-25℃, 54KPa	GB2423.25, IEC60068-2-40
Constant Humid and Hot	+40℃, 95%RH	GB2423.3, IEC60068-2-78
Random Vibration	5 - 10Hz, ASD 0.3 - 10g <sup>2</sup> /Hz, three directions of X, Y, Z axis	GB/T 4798.2-2008, IEC60721-3-2
Sinusoidal Vibration Response	10 - 150Hz, 1g, three directions of X, Y, Z axis	GB/T 11287-2000, IEC60255-21-1
Sinusoidal Vibration Endurance Test		
Sinusoidal Impulse Response	15g, pulse duration 11ms, three times in each direction of X, Y, Z axis	GB/T 114537-1993, IEC60255-21-2
Sinusoidal Impact Endurance Test		
Packaging Drop	1m, one corner, three edges and six sides	GB2423.8, IEC68-2-32

### Mechanical Specifications

Case Material	Metal (AL5052, SUS304)
Dimensions	125.00mm x 130.00mm x 70.00mm
Weight	1320g (Typ.)
Cooling Method	Free air convection

### Electromagnetic Compatibility (EMC)

EMI	CE	General standard	CISPR32 EN55032 CLASS B
		Industry/Light industry	IEC61000-6-3 AC port CLASS B, DC port CLASS A
			IEC61000-6-4 AC port CLASS A
		Classification society*	GD22-2015 10kHz - 30MHz, EMC1
Power station/Substation	IEC61850-3 CLASS A		

	Railway	IEC62236-3-2 (EN50121-3-2) Output port CLASS A +20dB		
		IEC62236-4 (EN50121-4) Output port CLASS A +20dB		
		IEC62236-5 (EN50121-5) AC port CLASS A		
	RE	General standard	CISPR32 EN55032 CLASS B	
		Industry/Light industry	IEC61000-6-3 CLASS B	
			IEC61000-6-4 CLASS A	
		Classification society	GD22-2015 150KHz - 2GHz, EMC1	
		Power station/Substation	IEC61850-3 CLASS A	
		Railway	IEC62236-3-2 (EN50121-3-2) CLASS B	
	IEC62236-4 (EN50121-4) CLASS B			
	IEC62236-5 (EN50121-5) CLASS B			
	Harmonic current	General standard	IEC/EN6100-3-2 Class A and Class D	
Railway		IEC62236-3-2 (EN50121-3-2) 50Hz - 2KHz		
	IEC62236-4 (EN50121-4) 50Hz - 2KHz			
EMS	ESD	General Standard	IEC/EN 61000-4-2 Output port Contact $\pm 8KV$ /Air $\pm 15KV$	perf. Criteria A
		Industry/Light industry	IEC61000-6-1 Contact $\pm 4KV$ /Air $\pm 8KV$	perf. Criteria A
			IEC61000-6-2 Contact $\pm 4KV$ /Air $\pm 8KV$	perf. Criteria A
		Wind power	NB/T 31017-2011 Contact $\pm 6KV$ /Air $\pm 8KV$	perf. Criteria A
		Classification society	GD22-2015 Contact $\pm 6KV$ /Air $\pm 8KV$	perf. Criteria A
		Power station/Substation	IEC61850-3 Contact $\pm 6KV$ /Air $\pm 8KV$	perf. Criteria A
			IEC61000-6-5 Contact $\pm 6KV$ /Air $\pm 8KV$	perf. Criteria A
		Railway	IEC62236-3-2 (EN50121-3-2) Contact $\pm 6KV$ /Air $\pm 8KV$	perf. Criteria A
	IEC62236-4 (EN50121-4) Contact $\pm 6KV$ /Air $\pm 8KV$		perf. Criteria A	
	IEC62236-5 (EN50121-5) Contact $\pm 6KV$ /Air $\pm 8KV$		perf. Criteria A	
	RS	General standard	IEC/EN 61000-4-3 10V/m	perf. Criteria A
		Industry/Light industry	IEC61000-6-1 80M - 1GHz, 3V/m; 1.4G - 6GHz, 3V/m	perf. Criteria A
			IEC61000-6-2 80M - 1GHz, 10V/m; 1.4G - 2GHz, 3V/m; 2 - 2.7GHz, 1V/m	perf. Criteria A
		Wind power	NB/T 31017-2011 80M - 1GHz, 10V/m	perf. Criteria A
		Classification society	GD22-2015 80M - 2GHz, 10V/m	perf. Criteria A
		Power station/Substation	IEC61850-3 80M - 3GHz, 10V/m	perf. Criteria A
			IEC61000-6-5 80M - 1GHz, 10V/m; 1G - 2.7GHz, 3V/m; 2.7G - 6GHz, 1V/m	perf. Criteria A
		Railway	IEC62236-3-2 (EN50121-3-2) 80M - 1GHz, 20V/m; 1.4GHz - 2GHz, 10V/m; 2G - 2.7GHz, 5V/m; 2.7G - 6GHz, 3V/m	perf. Criteria A
			IEC62236-4 (EN50121-4) 80M - 800MHz, 10V/m; 800MHz - 1GHz, 20V/m; 1.4G - 2GHz, 10V/m; 2G - 2.7GHz, 5V/m; 5.1G - 6GHz, 3V/m	perf. Criteria A
			IEC62236-5 (EN50121-5) 80M - 800MHz, 10V/m; 800MHz - 1GHz, 20V/m; 1.4G - 2GHz, 10V/m; 2G - 2.7GHz, 5V/m; 5.1G - 6GHz, 3V/m	perf. Criteria A
	EFT	General standard	IEC/EN 61000-4-4 $\pm 4KV$	perf. Criteria A
		Industry/Light industry	IEC61000-6-1 DC input, output and signal control port: $\pm 0.5KV$ , 5/100KHz, AC input and output port: $\pm 1KV$ , 5/100KHz	perf. Criteria A
			IEC61000-6-2 DC input, output and signal control port: $\pm 0.5KV$ , 5/100KHz, AC input and output port: $\pm 1KV$ , 5/100KHz	perf. Criteria A
		Wind power	NB/T 31017-2011 Power source and PE: $\pm 4KV$ , 5/100KHz, signal and control port: $\pm 2KV$ , 5/100KHz (Capacitive coupling clamp)	perf. Criteria A
Classification society		GD22-2015 $\pm 1KV$ , 5KHz; $\pm 2KV$ , 2.5KHz	perf. Criteria A	
Power station/Substation		IEC61850-3 AC, DC input output port, signal port, ground port: $\pm 2KV$	perf. Criteria A	
		IEC61000-6-5 AC, DC input output port: $\pm 2KV$ ; signal port: cable < 3m: $\pm 2KV$ , cable > 3m: $\pm 4KV$	perf. Criteria A	
Railway	IEC62236-3-2 (EN50121-3-2) Signal, control port: $\pm 2KV$ , 5KHz (Capacitive coupling clamp), AC, DC input output port: $\pm 2KV$ ,	perf. Criteria A		

Surge		5KHz	
		IEC62236-4(EN50121-4) Signal, control port: $\pm 2KV$ , 5KHz (Capacitive coupling clamp), AC, DC input output port: $\pm 2KV$ , 5KHz, PE ground/shell: $\pm 1KV$ , 5KHz	perf. Criteria A
		IEC62236-5(EN50121-5) Signal, control port: $\pm 2KV$ , 5KHz Capacitive coupling clamp), AC, DC input output port: $\pm 4KV$ , 5KHz, PE ground/shell: $\pm 1KV$ , 5KHz	perf. Criteria A
	General standard	IEC/EN 61000-4-5 AC input port: $\pm 4KV/\pm 6KV$	perf. Criteria A
	Industry/Light industry	IEC61000-6-1 DC input and output port: $\pm 0.5KV/\pm 1KV$ , AC input and output port: $\pm 1KV/\pm 2KV$ , signal and control port: $\pm 1KV$ common mode	perf. Criteria A
		IEC61000-6-2 DC input and output port: $\pm 0.5KV/\pm 0.5KV$ , AC input and output port: $\pm 1KV/\pm 2KV$ , signal and control port: $\pm 1KV$ common mode	perf. Criteria A
	Wind power	NB/T 31017-2011 AC, DC power source port: $\pm 1KV/\pm 2KV$	perf. Criteria A
	Classification society	GD22-2015 AC, DC power source port: $\pm 0.5KV/\pm 1KV$	perf. Criteria A
	Power station/Substation	IEC61850-3 AC, DC power source, signal port: $\pm 1KV/\pm 2KV$ , power carrier communication port: $\pm 2KV/4KV$	perf. Criteria A
		IEC61000-6-5 Signal, control port: $\pm 1KV$ common mode (If the cable < 10m, no test is required), DC input and output port: $\pm 1KV/\pm 2KV$ , AC input and output port: $\pm 2KV/4KV$	perf. Criteria A
Railway	IEC62236-3-2 (EN50121-3-2) Battery port, AC input port: $\pm 1KV/\pm 2KV$ ( $42\Omega$ output impedance)	perf. Criteria A	
	IEC62236-4 (EN50121-4) DC power source, signal, control port: $\pm 1KV/\pm 2KV$ ( $42\Omega$ output impedance), AC power source port: $\pm 1KV/\pm 2KV$	perf. Criteria A	
	IEC62236-5 (EN50121-5) DC input and output, signal, control port: $\pm 1KV/\pm 2KV$ , AC input and output port: $\pm 2KV/\pm 4KV$	perf. Criteria A	
CS	General standard	IEC/EN61000-4-6 10Vr.m.s	perf. Criteria A
	Industry/Light industry	IEC61000-6-1 AC input and output, signal, control port: 0.15M - 80MHz, 3V	perf. Criteria A
		IEC61000-6-2 AC input and output, signal, control port: 0.15M - 80MHz, 10Vr.m.s	perf. Criteria A
	Wind power	NB/T 31017-2011 0.15M - 80MHz, 10Vr.m.s	perf. Criteria A
	Classification society	GD22-2015 0.15M - 80MHz, 10Vr.m.s, Low frequency conduction immunity: AC input port, harmonic < 15 times 10%Un, harmonic = 15 - 100 times, from 10%Un to 1%Un, harmonic = 100 - 200 times, 1%Un; DC input port, 10%Un, 50 - 10kHz, apply power $\leq 2W$ (The applied voltage can be reduced)	perf. Criteria A
	Power station/Substation	IEC61850-3 AC, DC input, output, signal, control port, PE port: 0.15M - 80MHz, 10Vr.m.s	perf. Criteria A
		IEC61000-6-5 AC, DC input, output, signal, control port: 0.15M - 80MHz, 10Vr.m.s	perf. Criteria A
	Railway	IEC62236-3-2 (EN50121-3-2) AC/Battery input, signal, control port: 0.15M - 80MHz, 10Vr.m.s	perf. Criteria A
		IEC62236-4 (EN50121-4) AC, DC input, output, signal, control port: 0.15M - 80MHz, 10Vr.m.s	perf. Criteria A
		IEC62236-5 (EN50121-5) AC, DC input, output, signal, control port, PE port: 0.15M - 80MHz, 10Vr.m.s	perf. Criteria A
Voltage dips, short interruptions and voltage variations immunity	General standard	IEC/EN61000-4-11 0%, 70%	perf. Criteria B
	Industry/Light industry	IEC61000-6-1 0%, 0.5/1 period, 70%, 25/30 period @50/60Hz, 0%, 250/300 period @50/60Hz	perf. Criteria B and C
		IEC61000-6-2 0%, 1 period, 0%, 250/300 period @50/60Hz, 40%, 10/12 period @50/60Hz	perf. Criteria B and C
	Power station/Substation	IEC61850-3 AC input and output port: 100%, 5/50 period, DC input and output port: 100%, 0.05s	perf. Criteria B
		IEC61000-6-5 AC input and output port: 70%, 1 period, 40%, 50 period, 0%, 5 period, 0%, 50 period	perf. Criteria B
	Power frequency magnetic field	General standard	IEC/EN61000-4-8 100A/m, continuous, 1KA/m 1s
Industry/Light industry		IEC61000-6-1 50/60Hz, 30A/m	perf. Criteria A
		IEC61000-6-2 50/60Hz, 30A/m	perf. Criteria A



	Power station/Substation	IEC61850-3 100A/m, continuous, 1KA/m 1s	perf. Criteria A
		IEC61000-6-5 100A/m, continuous, 1KA/m 1s	perf. Criteria A
	Railway	IEC62236-4 (EN50121-4) 50Hz, 100A/m, DC 300A/m	perf. Criteria A
		IEC62236-5 (EN50121-5) 50Hz, 100A/m, DC 300A/m	perf. Criteria A
Intercom interference test		MS-SOP-DQC-007	perf. Criteria B

Note: 1. \*perf. Criteria:

A: The equipment shall continue to operate as intended without operator intervention;

B: After the test, the equipment shall continue to operate as intended without operator intervention;

C: Loss of function is allowed, provided the function is self-recoverable, or can be restored by the operation of the controls by the user in accordance with the manufacturer's instructions;

2. \*Tested with Mornsun filter P/N: FC-L06I-CCS.

Product Characteristic Curve

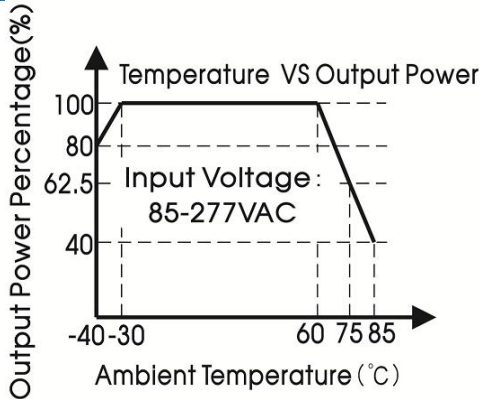

Figure 1

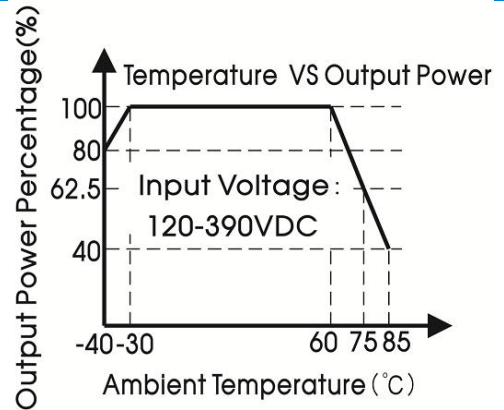

Figure 2

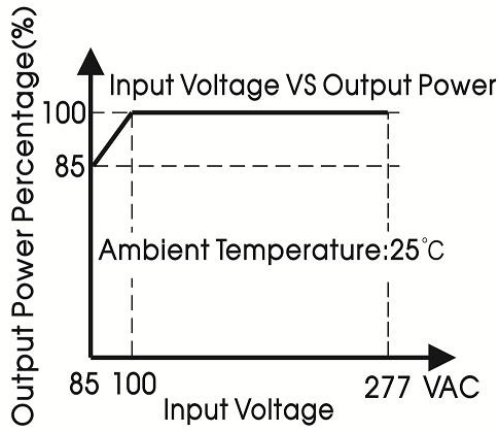

Figure 3

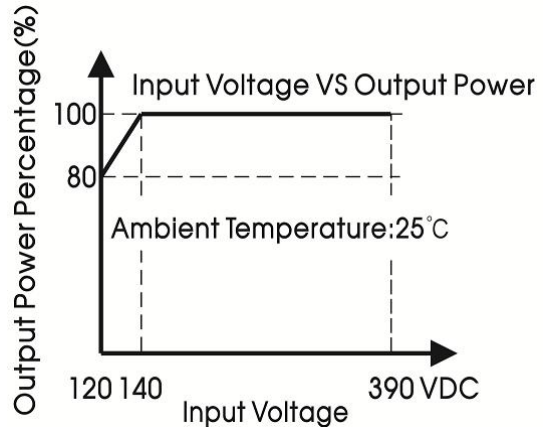

Figure 4

Over-current/ Short Circuit Protection Curve (Typ.)

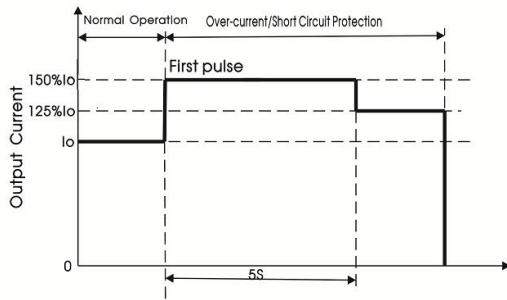

Figure 5

Transient Peak Current Function(Typ.)

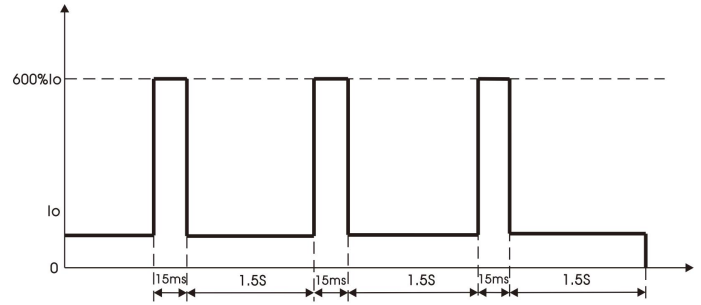

Figure 6

AC OK

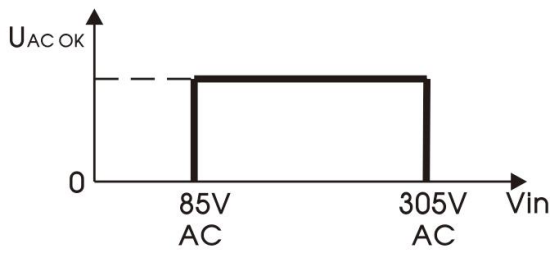

Figure 7

DC OK Behavior Curve (Typ.)

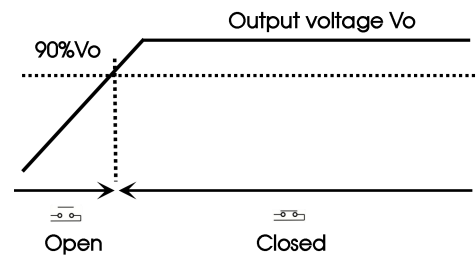

Figure 8

AC VS AC OK VS  $U_o$

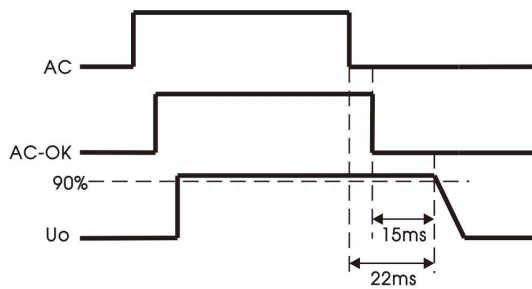

Figure 9

ON /OFF

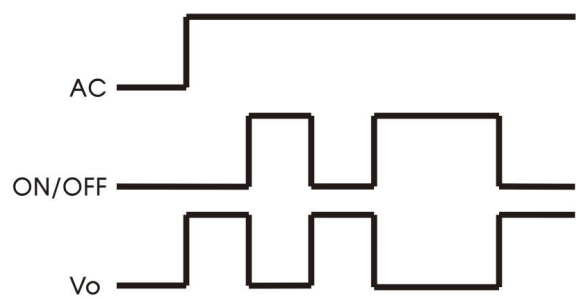

Figure 10

PF Vs Input Voltage (Full Load)

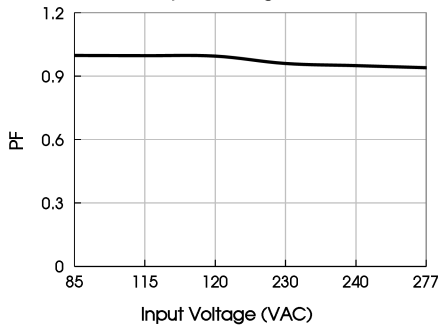

Figure 11

PF Vs Output Load ( $V_{in}=230VAC$ )

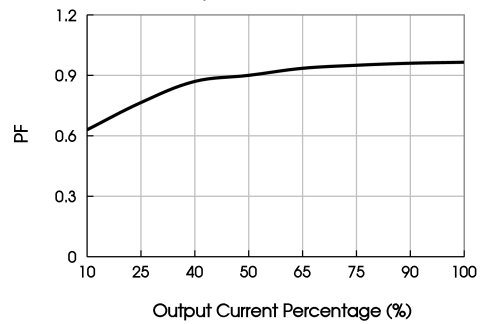

Figure 12



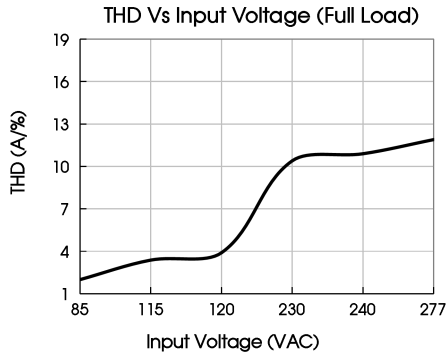

Figure 13

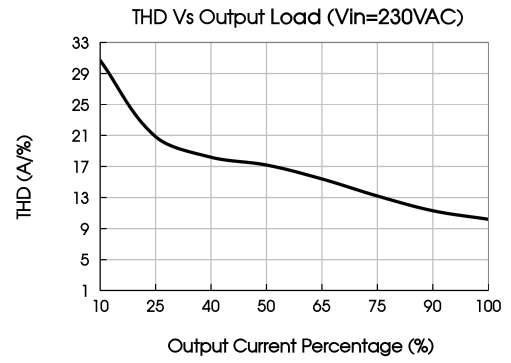

Figure 14

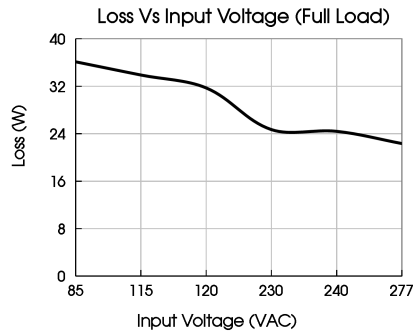

Figure 15

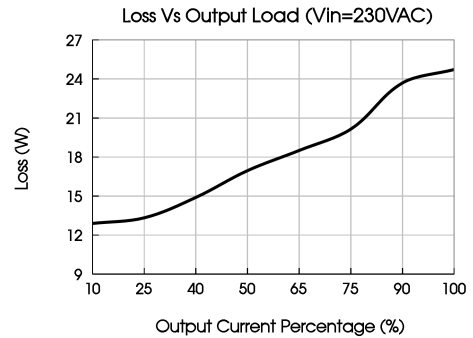

Figure 16

- Note: 1. All curves are for 24V output, measured at input 230VAC, 50Hz, output  $I_o$ , ambient temperature 25°C, unless otherwise stated;  
 2. With an AC input voltage between 85-100VAC and a DC input between 120 - 140VDC the output power must be derated as per the temperature derating curves;  
 3. FIG. 1, 2, 4 and 5 are carried out under the condition of 25CFM at a high temperature of 75°C to 85°C;  
 4. This product is suitable for applications using natural air cooling, for applications in closed environment please consult Mornsun FAE.

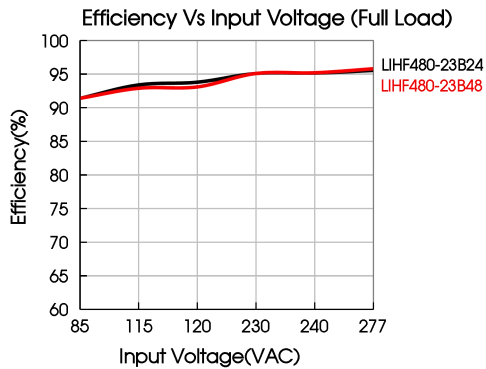

Figure 17

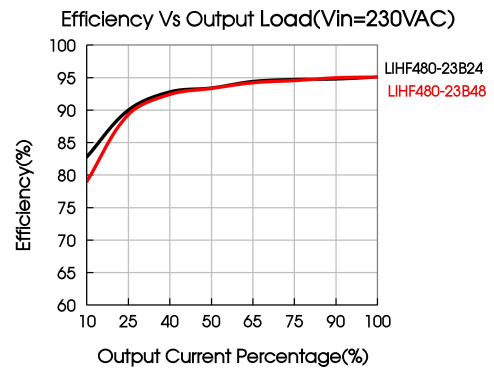

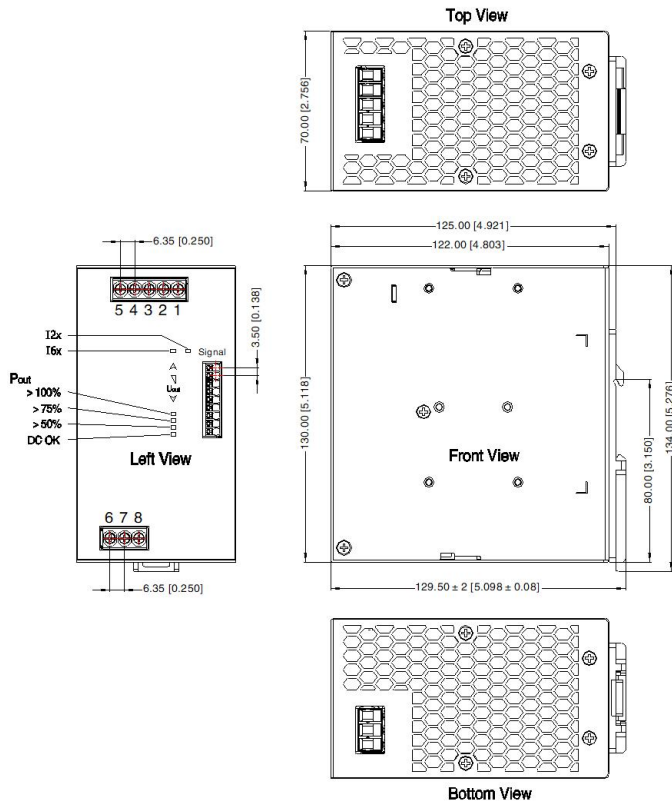

Figure 18

## Dimensions and Recommended Layout

THIRD ANGLE PROJECTION 

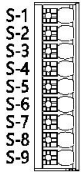

Pin-Out	
Pin	Mark
1	-Vo
2	-Vo
3	-Vo
4	+Vo
5	+Vo
6	⊕
7	AC(N)
8	AC(L)

Signal	Pin-Out	
	Pin	Mark
	S-1	DC
	S-2	OK
	S-3	RS485-A
	S-4	RS485-B
	S-5	ON/OFF
	S-6	SGND
	S-7	AC OK
	S-8	PCS
	S-9	PCS

Note:  
Unit: mm[inch]  
Wire range: Input: 18-10AWG(12-10AWG for pin6)  
Output: 24V: 10AWG  
48V: 14-10AWG  
Signal: 24-16AWG  
Tightening torque: Max 0.5N · m  
Mounting rail: TS35, rail needs to connect safety ground  
General tolerances: ± 1.00[± 0.039]



**WARNING** Risk of electrical shock, fire, personal injury or death:

**AVERTISSEMENT** AVERTISSEMENT Risque de choc électrique, d'incendie, de blessures corporelles ou

- Do not use the power supply without proper grounding (Protective Earth). Use the terminal on the input block for earth connection and not one of the screws on the housing;  
N'utilisez pas l'alimentation électrique sans mise à la terre appropriée (Terre protectrice). Utilisez le terminal sur le bloc d'entrée pour la connexion terrestre et non pas une des vis sur le boîtier;
- Turn power off before working on the device, protect against inadvertent re-powering;  
Éteignez l'alimentation avant de travailler sur l'appareil, protégez-vous contre la réénergisation accidentelle;
- Make sure that the wiring is correct by following all local and national codes;  
Assurez-vous que le câblage est correct en suivant tous les codes locaux et nationaux;
- Do not modify or repair the unit;  
Ne modifiez pas ou ne réparez pas l'appareil;
- Do not open the unit as high voltages are present inside;  
Ne modifiez pas ou ne réparez pas l'appareil;
- Use caution to prevent any foreign objects from entering the housing;  
Faire preuve de prudence pour empêcher les objets étrangers d'entrer dans le logement;
- Do not use in wet locations or in areas where moisture or condensation can be expected;  
Faire preuve de prudence pour empêcher les objets étrangers d'entrer dans le logement;
- Do not touch during power-on, and immediately after power-off, hot surfaces may cause burns;   
Ne touchez pas pendant l'alimentation et, immédiatement après l'alimentation, les surfaces chaudes peuvent causer des brûlures.
- For ambient temperature ≤60°C, use ≥90°C - copper wire only; for ambient temperature >60°C to 85°C, use ≥105°C - copper wire only; use only wires with a minimum dielectric strength of 300V (input) and 60V (output);  
Température ambiante ≤60°C, utiliser ≥90°C - seulement fils de cuivre; Température ambiante >60°C et 85°C, utiliser ≥105°C - seulement

fil de cuivre; Uniquement pour l'utilisation de fils de cuivre d'une résistance d'isolation minimale de 300V (d'entrée) et 60V (de sortie).

Note:

1. For additional information on Product Packaging please refer to [www.mornsun-power.com](http://www.mornsun-power.com). Packaging bag number: 58220315;
2. Unless otherwise specified, parameters in this datasheet were measured under the conditions of Ta=25°C, humidity <75% RH with nominal input voltage and rated output load;
3. The room temperature derating of 5°C/1000m is needed for operating altitude greater than 2000m;
4. All index testing methods in this datasheet are based on our company corporate standards;
5. In order to improve the efficiency at high input voltage, there will be audible noise generated, but it does not affect product performance and reliability;
6. We can provide product customization service, please contact our technicians directly for specific information;
7. Products are related to laws and regulations: see "Features" and "EMC";
8. The out case needs to be connected to PE ( $\oplus$ ) of system when the terminal equipment in operating;
9. Key to adjust,  $\Delta$  key for voltage increase,  $\nabla$  key for voltage decrease;
10. Our products shall be classified according to ISO14001 and related environmental laws and regulations, and shall be handled by qualified units.

## Matlog

4 avenue du Vieil Etang | Espace Ouest - Hall A | 78180 Montigny le Bretonneux  
+33 1 80 97 92 70 | [contact@matlog.com](mailto:contact@matlog.com) | [www.matlog.fr](http://www.matlog.fr)

# LIHF480-23Bxx Series Power Supply Application Notes

## Content

1. Mechanical Specification.....	12
1.1 Input terminal (CN1).....	12
1.2 Output terminal (CN2).....	13
1.3 Signal connection terminal (CN5).....	13
1.4 Status display LED.....	14
1.5 Output voltage regulation.....	14
2. Circuit block diagram.....	12
3. Function Manual.....	15
3.1 Input Requirements.....	15
3.2 Output Requirements.....	15
3.3 Power failure holding time and AC OK advance warning time.....	15
3.4 Output Over-Voltage Protection (OVP).....	16
3.5 Transient peak current Function.....	17

3.6 Output Over-Current and Short Circuit protection (OCP And SCP).....	17
3.7 Over Temperature Protection (OTP).....	17
3.8 Output Power Derating .....	17
3.9 Remote Control Switch.....	18
3.10 DC_OK Signal.....	19
3.11 Used in series.....	19
3.12 Work in parallel.....	20
3.13 PC Monitoring.....	21
3.14 Back Voltage Load.....	23
4. Installation Requirements.....	24
4.1 Safety Introduction.....	24
4.2 Safety Requirements.....	24
4.3 High-voltage Holding test.....	24
4.4 Installation Methods.....	24

## 1. Mechanical Specification

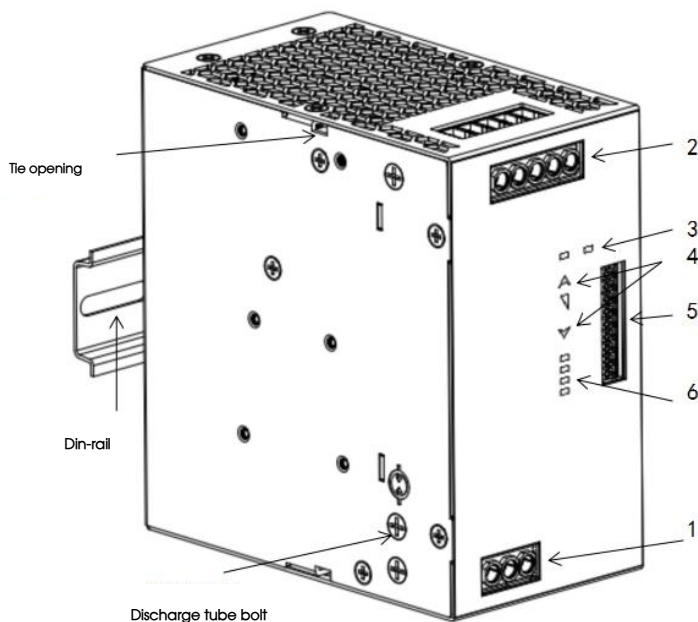



Structure Instruction	
1	Input terminal (CN1)
2	Output terminal (CN2)
3	Mode status display LED
4	Voltage adjustment button
5	Signal connection terminal (CN5)
6	Power indicating LED

Figure 1: LIHF480-23Bxx Appearance Information

## 1.1 Input Terminal (CN1)

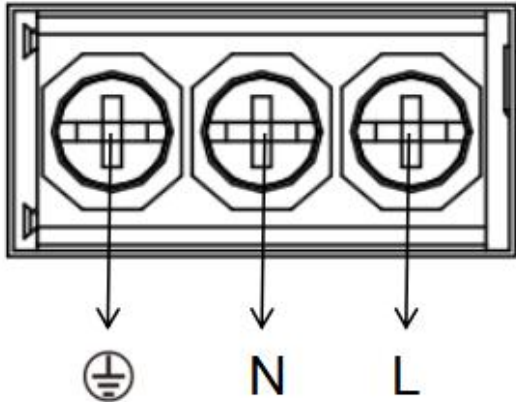
3 Position 6.35 mm Barrier Terminal Blocks is used as Input terminal.



Pin	Features
L	Live
N	Neutral
	Protective Earth

Line size: 18-10AWG  
Torque: Max 0.5Nm

## 1.2 Output Terminal (CN2)

6 Position 6.35 mm Barrier Terminal Blocks is used as Output terminal.

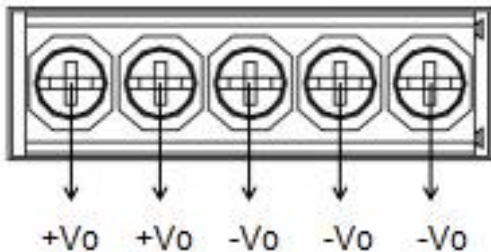

Pin	Features
+Vo	Positive output
-Vo	Negative output

Line size: 14-10 AWG  
Torque: Max 0.5 Nm

## 1.3 Signal Connection Terminal (CN5)

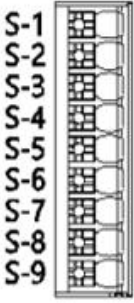
Signal	Pin-Out	
	Pin	Mark
	S-1	DC
	S-2	OK
	S-3	RS485-A
	S-4	RS485-B
	S-5	ON/OFF
	S-6	SGND
	S-7	AC OK
	S-8	PCS
	S-9	PCS

Line size: 24-16 AWG  
Torque: 0.5 Nm

### 1.4 Status Display LED



#### Power status indicator LED

LED	Status
LED1 ON	DC-OK, Output Power $\leq$ 50%
LED1-LED2 ON	$75\% \geq$ Output Power $>$ 50%
LED1-LED3 ON	$100\% \geq$ Output Power $>$ 75%
LED1-LED4 ON	Output Power $>$ 100%
LED4 Flashing	$180\% \geq$ Output Power $>$ 125%

#### Mode status indicator

LED	Status
LED5 Brigh	12x, 2 times peak current
LED6 Brigh	16x, 6 times transient peak current

### 1.5 Output voltage regulation

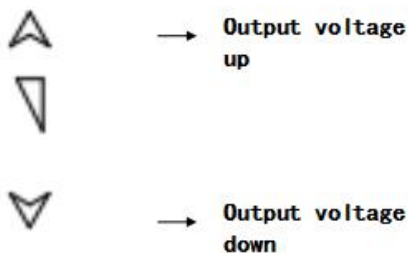

Model	Rated Output Voltage	Output Voltage Adjustable Range
LIHF480-23B24	24VDC	24-28VDC
LIHF480-23B48	48VDC	48-55VDC

## 2. Circuit block diagram

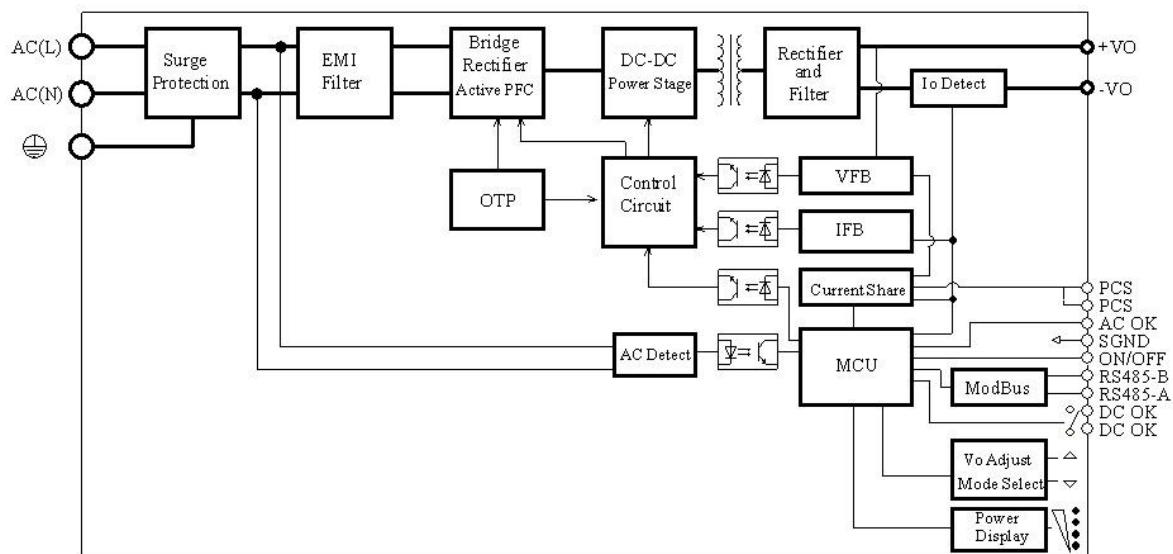

## 3. Function Manual

### 3.1 Input Requirements

The AC input voltage and DC input voltage must be within the defined voltage range (refer to the data sheet), otherwise the power supply may not work properly or even fail. An 10A/250VAC fuse has been connected to the power module. To better protect the power module, you are advised to use a circuit breaker larger than 10A (Strengthen protection, not necessary access requirements).

### 3.2 Output Requirements

At any output voltage value, if it is necessary to operate normally, the highest pull current and power must not exceed the rated specified value, and the output current must not exceed the maximum output current value.

### 3.3 Power Failure Holding Time And AC OK Advance Warning Time

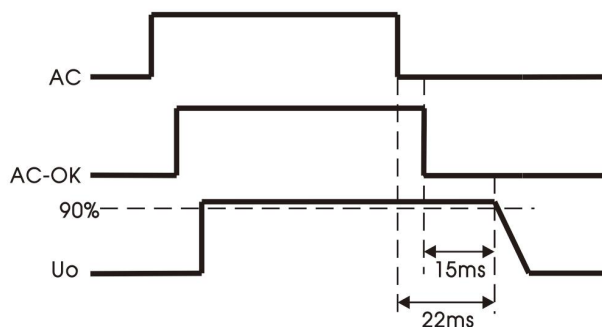

Item	Working conditions	Min.	Typ.	Max.	Unit
Power-off hold time	115VAC/230VAC, full load	--	22	--	ms
AC OK Advance warning time	115VAC/230VAC, full load	The warning time is higher than $U_o \times 90\%$		--	ms

### 3.4 Output Over-Voltage Protection (OVP)

The main circuit output will be off when the output voltage reaches the over-voltage protection value. When it occurs, the output enters the hiccup mode with 5s. After the abnormal removed, the output returns to normal.

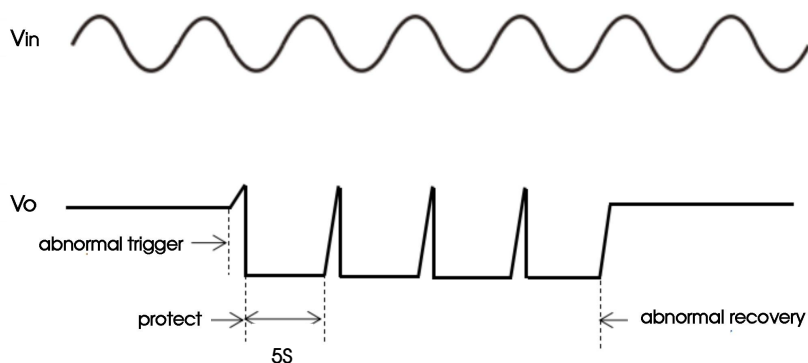

### 3.5 Transient Peak Current Function

Transient peak current means that the output can work at 600%  $I_o$  constant current. When the output is short circuit or needs a lot of current, it can work at 600%  $I_o$  constant current for 3 times for 15ms (typ.), which can provide long-term short-circuit protection and self-recovery.

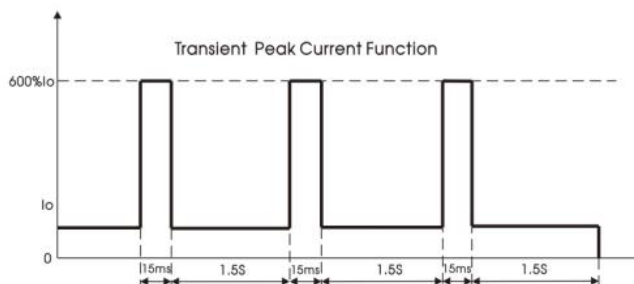

Note: The function of the 600% transient peak current function can be turned on or off in the following two ways, with a state of up to 175% current limit after being turned off:



Method 1: Hold down the two buttons of voltage regulation for 3s at the same time, and the LED display changes from I6x to I2x;

If you hold down 3s again, you can turn on the 600% peak current function again.

Method 2: The function can be turned on or off by writing the corresponding instruction to address 65 through Modbus communication:

Site	Data Type	Variable Name	Function Declaration
65	Uint16	Control_Mode	Control mode: 1: Turn on 600% transient peak current 0: Turn off 600% transient peak current

Name	Value	Unit	Read	Command	Write	Block	Address	Count	Offset	Digit	Coefficient
Control Mode	0X0001		Read		Write	RW	65	1	0	16	1

### 3.6 Output Over-Current and Short Circuit protection (OCP And SCP)

**Static power mode:** When the output current exceeds 100% of the rated output current but does not exceed 125% of the rated output current, the output enters the static power mode. The static power of the product is 125%Io (typ.), which can work for a long time and does not enter the protection state.

**Dynamic power mode:** When the output current exceeds 125% of the rated output current and does not exceed 175% of the rated output current, the output will enter the dynamic power mode. The dynamic power point of the product is 150%Io (typ.), and the product will enter the static power mode after working for 5S (typ.). The working time and shutdown time can be self-adapted according to different load conditions, which can provide long-term protection and self-recover.

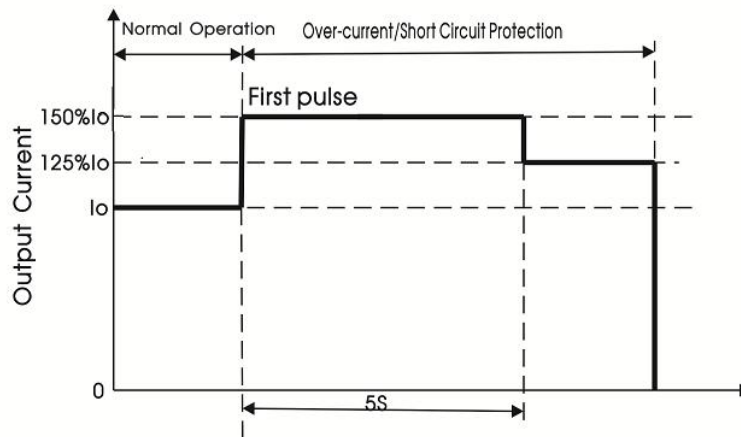

### 3.7 Over Temperature Protection (OTP)

When the ambient temperature of the power supply exceeds the rated temperature for a period of time, the power supply will turn off the output and enter the hiccup state. After the ambient temperature drops to the set value, the power supply will resume normal operation.

### 3.8 Output Power Derating

When the input voltage is greater than 100VAC (or 140VDC), only need to derate according to the temperature derating curve;

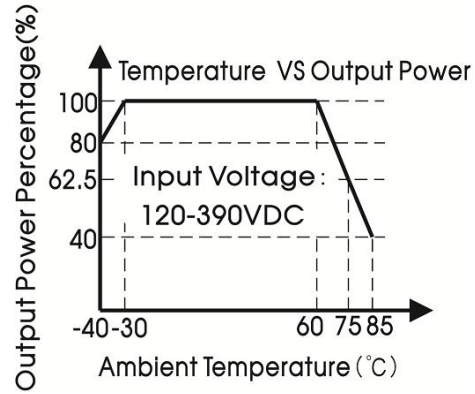
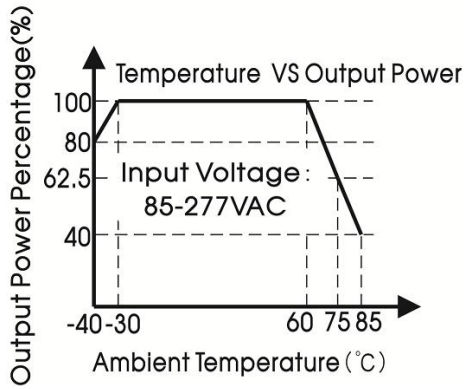

When the input voltage is lower than 100VAC (or 140VDC), the output power will be derated according to the following input voltage derating curve requirements after the temperature derating.

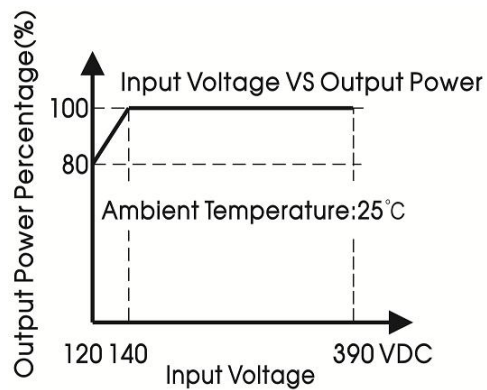
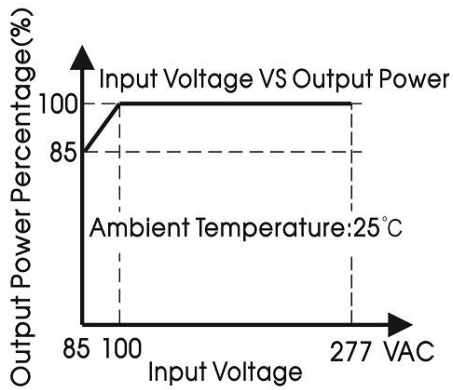

### 3.9 Remote Control Switch

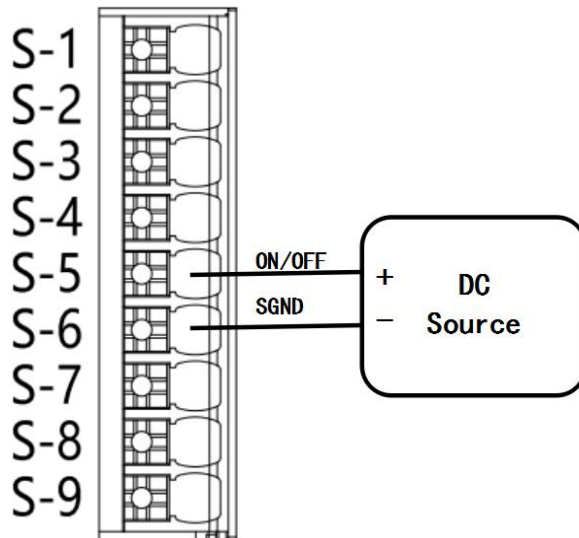

ON/OFF (S-5) and SGND(S-6)Switch	Output Status
DC Source power supply voltage is less than 0.8VDC	Normal output
DC Source supply voltage is greater than 4VDC less than 20VDC	Output Off

If the power module is connected to the power supply, the ON and OFF of its output can be controlled by applying an external voltage between the ON/OFF signal pin and SGND.

### 3.10 DC\_OK Signal

The DC\_OK signal is used to monitor whether the power supply is working normally, at the first and second pins of the signal terminals. When the output voltage is greater than 90% of the rated output voltage, the DC\_OK signal acts, the DC\_OK at the output terminal is connected, and LED1 lights up. When the output voltage is less than 85% of the rated output voltage, the DC\_OK of the output terminal is disconnected, and LED1 is off.

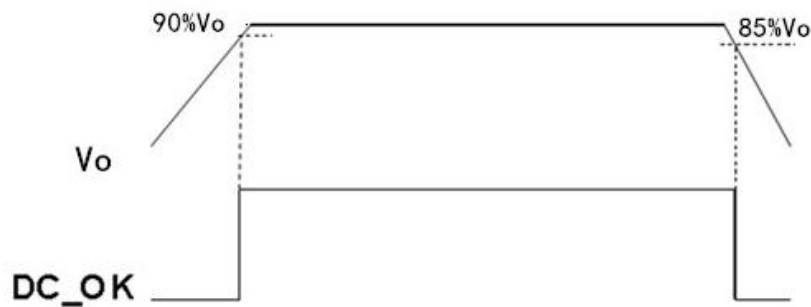

### 3.11 Used in series

The same type of power supply can be connected in series to increase the output voltage. As long as the total output voltage does not exceed 150Vdc, you can connect as many power supplies as you need. Voltages in excess of 60Vdc are no longer considered Safety Extra Low Voltage Circuits (SELV) and can therefore be dangerous. When installing such voltages, it must be protected against touch.

Please avoid generating feedback voltage to the output terminals (eg from a decelerating motor or battery).

Keep a 15mm (left/right) installation gap between the two power supplies and avoid installing the power supplies on top of each other. Do not connect the power supplies in series in an installation orientation other than the standard installation orientation (input terminals down).

Note that leakage current, electromagnetic interference, inrush current and harmonics will increase when multiple power supplies are used.

Refer to the figure below for the wiring method:

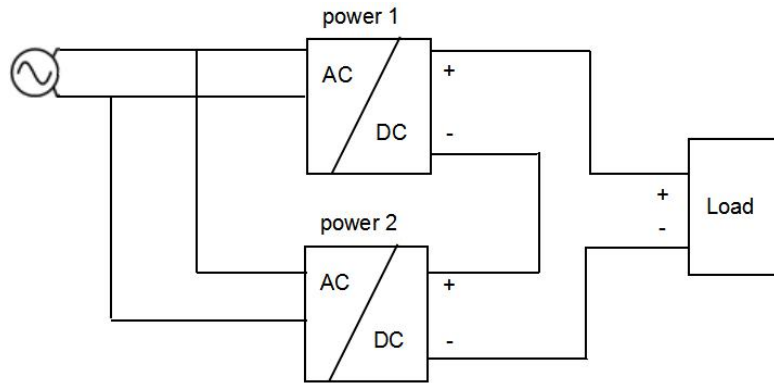

### 3.12 Work in parallel

The PSU supports 6 PCS in parallel current equalization.

The current sharing bus (PCS) between multiple machines can be short connected to each other, and can be connected by jumper wire

The output voltage difference of each single module is less than 100mV, which can obtain a better line-end output voltage and current sharing comprehensive effect. The connection mode of the current-sharing function is shown in the figure below:

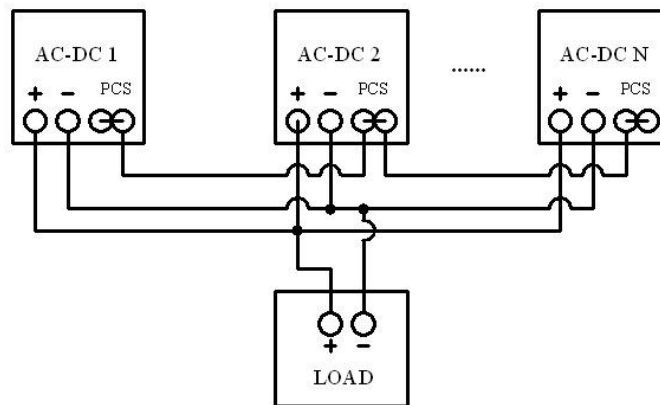

Note: 1. When used in parallel, the number of parallel modules cannot exceed 6 PCS.

2. When the power modules work in parallel, there is an active current sharing circuit inside to ensure that the current between each module remains balanced.

Active current sharing circuit adopts automatic master-slave current sharing mode. Each power module has a current sharing bus signal (PCS). When working in parallel, the current sharing buses of all power modules must be connected together. It can be connected through jumper wires. The power terminal has reserved two internal connected PCS ports of the current sharing bus signal, namely, two pins of port bit 8 and 9, which can be connected to one of the pins in use.

The output voltage of each power module will affect the current sharing accuracy. The output voltage of the power module is rated voltage  $\pm 100\text{mV}$ . In practical applications, if the output voltage value needs to be adjusted, the output voltages of all parallel power modules need to be adjusted to the same voltage. The recommended voltage range is: target voltage value  $\pm 100\text{mV}$ .

After the output load of each power module is greater than 50% of the rated load, the current sharing accuracy is required to be  $\pm 5\%$ . The calculation formula of current sharing is:

$$\text{Power supply 1's average accuracy} = \frac{I_{o1} - (I_{o1} + I_{o2}) / 2}{(I_{o1} + I_{o2}) / 2} * 100\%$$

$$\text{Power supply 2's average accuracy} = \frac{I_{o2} - (I_{o1} + I_{o2}) / 2}{(I_{o1} + I_{o2}) / 2} * 100\%$$

$I_{o1}$ : The output current value of the power supply 1 in the parallel power module.

$I_{o2}$ : The output current value of the power supply 2 in the parallel power module.

### 3.13 PC Monitoring

In a parallel system, if you need to identify the information of the power modules, you need to monitor each parallel power module by the host computer. The connection diagram is as follows:

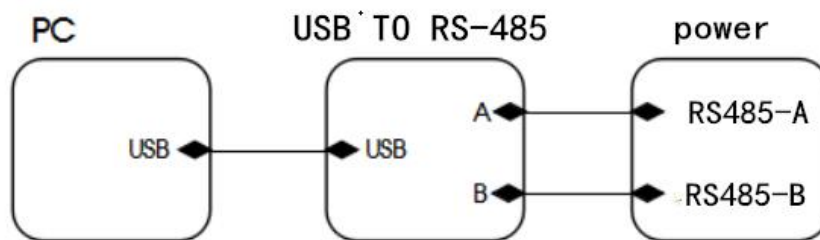

That is, connect the RS485-A and RS485-B of the signal terminals to the USB to interface module.

The upper computer "MThings" of Modbus can be used to read and configure the power supply products, or the relevant instructions can be sent directly through the corresponding address.

Function name and corresponding address, quantity and coefficient of ModBus are shown below:

ID	Name	Value	Unit	Read	Command	Write	Block	Address	Count	Offset	Digit	Coefficient
1	SN	20221111001110		Read	--	Write	RW	0	32	0	512	1
2	Product Type	LIHF240-23B24		Read	--	Write	RW	32	32	0	512	1
3	Firmware Version	3		Read	--	Write	RW	64	1	0	16	1
4	Control Mode	0X0001		Read	--	Write	RW	65	1	0	16	1
5	MODBUS ID	0		Read	--	Write	RW	66	1	0	16	1
6	MODBUS Baud Rate SET	1		Read	--	Write	RW	67	1	0	16	1
7	Run Time	0.381152	h	Read	--	Write	RW	72	2	0	32	0.000277
8	Vo Set	24.000000	V	Read	--	Write	RW	74	2	0	32	1
9	Input Voltage	228.412827	V	Read	--	Write	RW	76	2	0	32	1
10	Output Voltage	24.079004	V	Read	--	Write	RW	80	2	0	32	1
11	Output Current	9.890471	A	Read	--	Write	RW	82	2	0	32	1
12	Output Power	238.158234	W	Read	--	Write	RW	84	2	0	32	1
13	Inside Temperature	84.000000	°C	Read	--	Write	RW	86	2	0	32	1
14	Output State1	0X0003		Read	--	Write	RW	88	1	0	16	1
15	Warning State2	0X0000		Read	--	Write	RW	89	1	0	16	1
16	Remaining Service Life	43676.978848	h	Read	--	Write	RW	90	2	0	32	0.000277
17	Remote ON/OFF	1		Read	--	Write	RW	128	1	0	16	1
18	Running Time from ACON	185	s	Read	--	Write	RW	130	2	0	32	1
19	Output OVP Times	0		Read	--	Write	RW	132	1	0	16	1
20	Output OCP Times	0		Read	--	Write	RW	133	1	0	16	1
21	Input UVP Times	0		Read	--	Write	RW	136	1	0	16	1
22	Input OVP Times	0		Read	--	Write	RW	137	1	0	16	1
23	OTP Times	0		Read	--	Write	RW	138	1	0	16	1

Note: 1. Open the upper computer software, import the configuration, click batch read to obtain the related information. In the command column, input relevant information can be configured, such as the output voltage configuration.

2. The default baud rate is 9600bps. Configure the baud rate as follows.

Configuration instructions	Baud rate(bps)
1	9600
2	38400
3	57600
4	115200

3. After the serial port communication address (ModBus ID) is configured, power off the device and restart it to take effect one minute later.

4. Function and data format definition of MODBUS communication register.

In byte type data 4, the high half word comes first and the low half word comes last

Address	Data Type	Name Of Variable	Function Description	Read And Write Permissions
0-31	Char	SN_MODEL	Product serial number	Read-Only
32-63	Char	Product_MODEL	Product Model Number	Read-Only
64	Uint16	Version	Product firmware version	Read-Only
65	Uint16	control_mode	Control mode: 1: Turn on 600% transient peak current 0: Turns off 600% transient peak current	Read/Write
66	Uint16	Add	Serial communication address (ModBus ID)	Read/Write
67	Uint16	Baud	Baud rate of serial port communication	Read/Write
72	Uint32	RUNTIME	Accumulated running time (unit "s", converted to "h" by the host computer/user)	Read-Only
73				
74	Float32	Set_VOL	Output voltage configuration	Read/Write
75				
76	Float32	VAC_RMS	AC input voltage	Read-Only
77				
80	Float32	Vout	Output voltage	Read-Only
81				
82	Float32	Iout	Output current current	Read-Only
83				
84	Float32	Pout	Power output	Read-Only
85				
86	Float32	Temperature	Internal temperature	Read-Only
88	Uint16	State1	Output State1 (0~3byte): DC-OK (0), AC-OK (1), OVP (2), OCP (3); 1 for OK or Protection State, 0 for NOK	Read-Only

89	Uint16	State2	Warning State2 (0~5byte): Input UV Warning (1), Input OV Warning (2), Remaining Service Life Warning (3), Over Temperature Warning (4), Failure Warning (5); 1 for Warning, 0 for Normal	Read-Only
90	Float32	Life	Remaining Service Life (unit "s", converted to "h" by the host computer/user)	Read-Only
91				
128	Uint16	ON/OFF	Remote ON/OFF, 1 for ON, 0 for OFF	Read/Write
130	Uint32	RUNINGTIME	running time (unit "s", converted to "h" by the host computer/user)	Read-Only
131				
132	Uint16	OVP_TIMES	Output OVP Times	Read/Write for Reset to zero
133	Uint16	OCP_TIMES	Output OCP Times	Read/Write for Reset to zero
136	Uint16	INPUT_UVP_TIMES	Input UVP Times	Read/Write for Reset to zero
137	Uint16	INPUT_OVP_TIMES	Input OVP Times	Read/Write for Reset to zero
138	Uint16	OTP_TIMES	OTP Times	Read/Write for Reset to zero

### 3.14 Back Voltage Load

Loads such as decelerating motors, inductors can feed voltage back into the power supply. This property is also known as feedback voltage resistance or resistance to opposing electromagnetic forces.

LIHF480-23B24: ① The feedback voltage within 30V, product will not shut down, and it will automatically recover after no feedback voltage in; ②If the feedback voltage exceeds 30V and is less than 35V, the output will be shut down and restart after 5S.

LIHF480-23B48: ① The feedback voltage within 57V, product will not shut down, and it will automatically recover after no feedback voltage in; ②If the feedback voltage exceeds 57V and is less than 63V, the output will be shut down and restart after 5S.

The power supply is resistant to the voltage that the load feeds back into the power supply and will not fail regardless of whether the power supply is on or off. The following function diagram:

Maximum allowable feedback voltage	
Model	Maximum feedback voltage
LIHF480-23B24	35VDC

LIHF480-23B48

63VDC

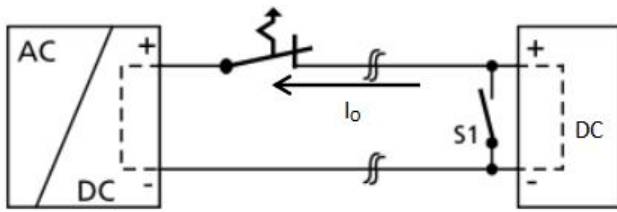

## 4. Installation Requirements

### 4.1 Safety Introduction

**WARNING: RISK OF ELECTRIC SHOCK DURING HIGH VOLTAGE WORKING WITH THIS EQUIPMENT**

- After the power module is disconnected from the input AC or DC power, leave it for at least one minute before starting to operate it.
- When installing the input cable to the power module, first connect the ground terminal, and then connect the L and N cables.
- When removing the input wire, first remove the L wire and N wire, and then remove the ground wire
- When disassembling and assembling, make sure that no objects fall into the inside of the power module.
- Be careful of high temperature burns
- After the power module works in a high temperature environment, wait for its shell to cool before operating it.
- This product needs to be installed by professionals and needs to be used with other equipment.

### 4.2 Safety Requirements

When installing, pay attention to the primary side and the protective ground. The creepage distance and electrical clearance of the primary side and the secondary side meet the safety requirements, refer to EN/UL61010.

### 4.3 Withstand pressure test

The screw at the side mark of the casing should be removed when the product is tested for pressure resistance .

The built-in gas discharge tube protects the power supply from asymmetric interference variables (e.g. EN 61000-4-5). Each power supply sustained voltage test will cause a very high load on the power supply. Therefore, unnecessary load or damage to the power supply caused by high test voltage should be avoided. Disconnect the device's built-in gas discharge tube if necessary to use a higher test voltage. Reconnect the gas discharge tube after successful completion of the test.



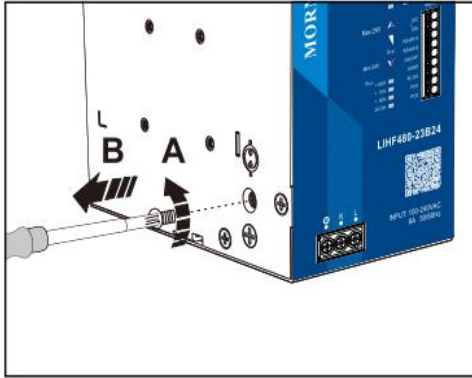

**Danger:** Using the wrong gas discharge tube bolts can result in an electric shock hazard or power supply damage. To connect the gas discharge tube, use only the gas discharge tube bolts originally installed in the power supply.

Disconnect the gas discharge tube by performing the following steps.

1. Disconnect the power supply to the unit ;
2. Completely unscrew the  bolt to ensure that the gas discharge tube is connected to a safe position. Now that the gas discharge tube has been disconnected, it no longer functions;
3. Perform sustained voltage test on the power supply;
4. After successful voltage test, screw the gas discharge tube back to the power supply completely.

#### 4.4 Installation method

Installation direction: When installing, the port of the output end should be upward, and the port of the input end should be downward. (See below)

Note: Pay attention to the temperature rise of the device in different installation modes. Derate the device according to the actual situation.

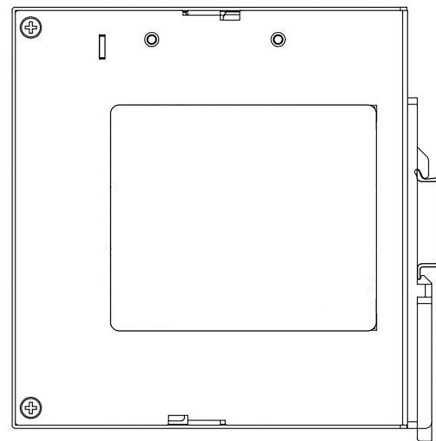
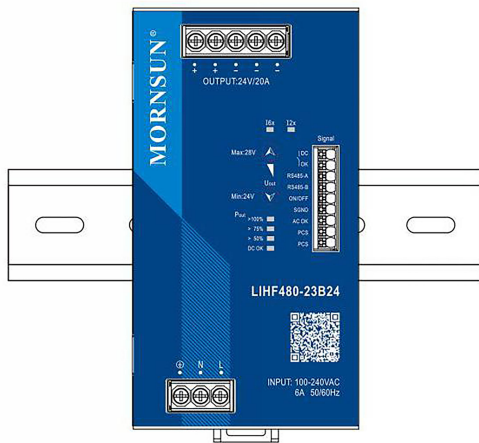

Various Installation Methods

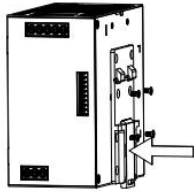

① Mounting the universal DIN rail power supply.  
(Forward Installation. Label is needed to be removed)

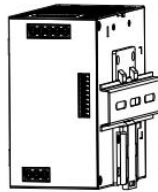

Mounting the universal DIN rail power supply.  
(Reverse Installation. Label is needed to be removed)

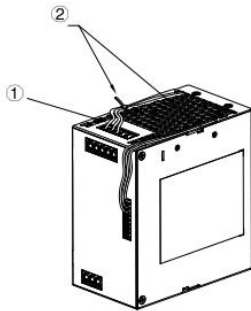
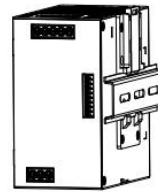

① After connecting the terminal to the connecting wire, lay and align the connecting wire.  
② Tie up the stripes with cables and fix the connecting wires through the gaps on the both sides of the shell.

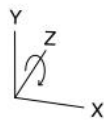

Rotate the installation position  
(0° Z-Axis)

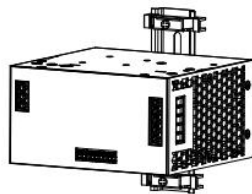
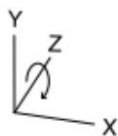
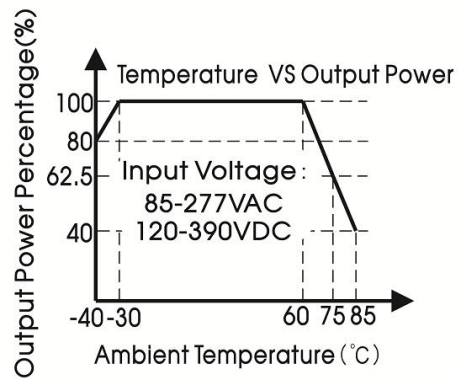

Rotate the installation position  
(90° Z-Axis)

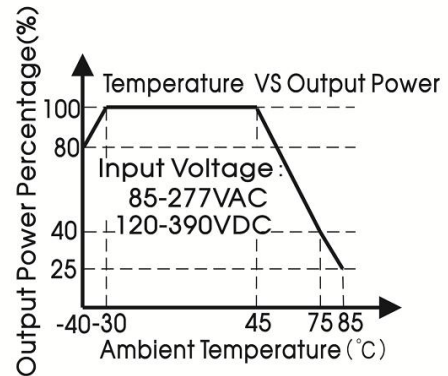

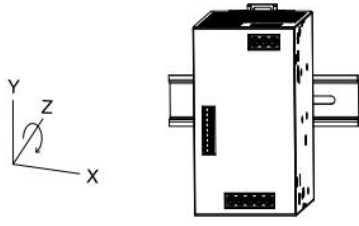

Rotate the installation position  
(180° Z-Axis)

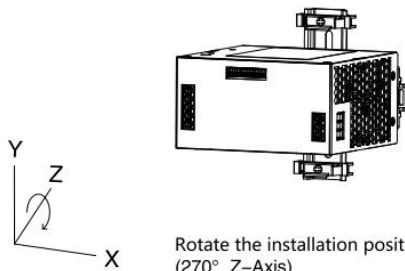
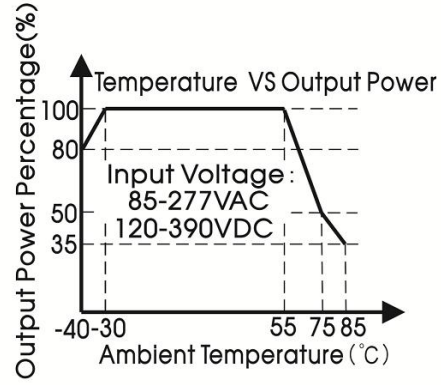

Rotate the installation position  
(270° Z-Axis)

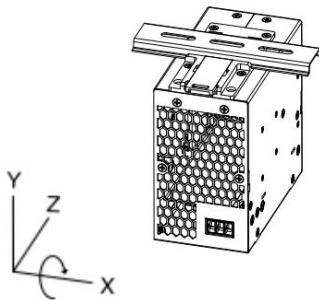
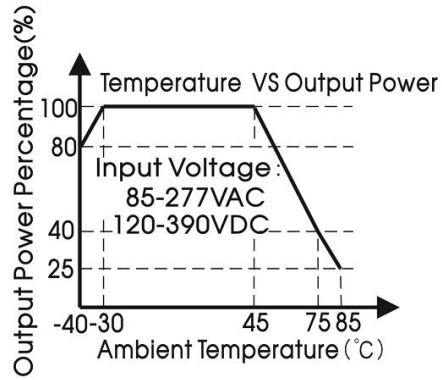

Rotating mounting position  
(90° X-Axis)

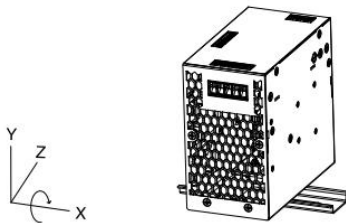
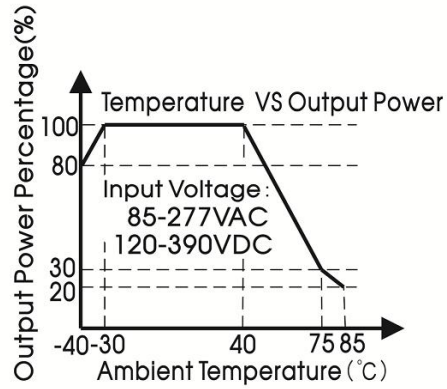

Rotate the installation position  
(270° X-Axis)

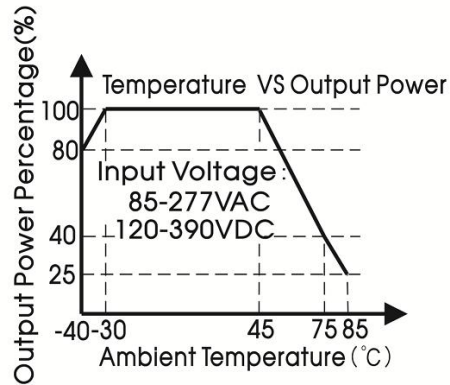

Materials required in the installation		
1	Product	1PCS
2	Phillips screwdriver Slotted screwdriver	1PCS
3	TS35/7.5 or TS35/15	1PCS
4	24-10AWG Wire	/ PCS
5	The content is for reference only. Regarding the actual wire diameter and tightening torque, refer to the dimensional drawing.	

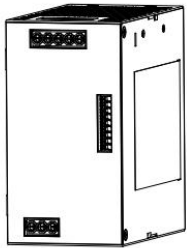

Product



Phillips screwdriver  
Slotted screwdriver  
Diameter : 3mm

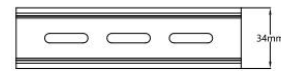

TS35/7.5 or TS35/15



Installation steps ①-②

① Clamp the buckle of the product into the TS35 DIN rail.

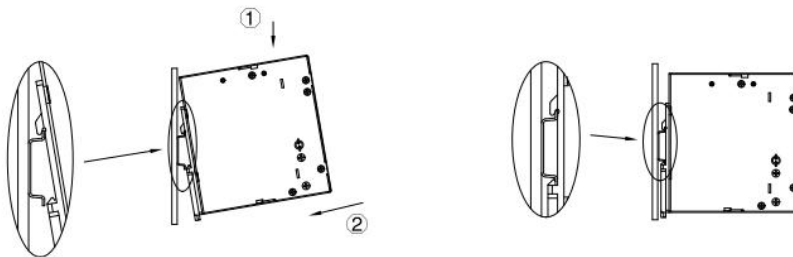

② Push the product vertically towards the TS35 DIN rail until hearing the sound of the buckle snapping into it.

Disassembly Steps ③-④

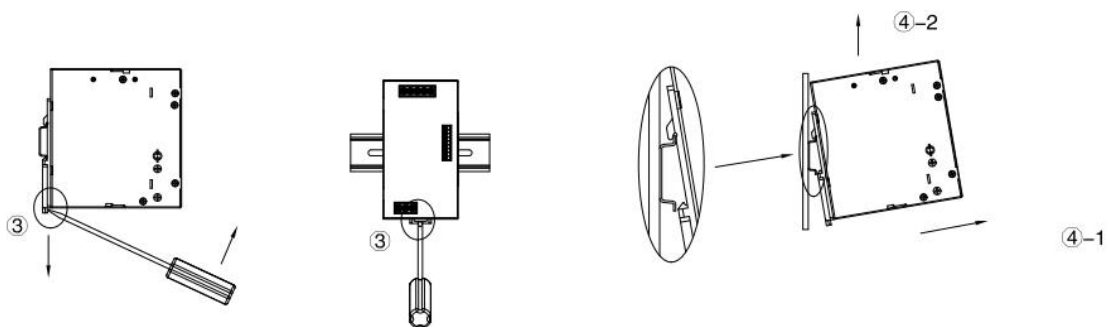

③ After inserting the slotted screwdriver into the square groove at the bottom of the buckle, push the slider of the buckle downward in the direction shown in the figure.

④ Hold the bottom of the product and push it outwards while pushing down the slider, then lift the product up to take the product out of the DIN rail.



Wiring / Unwiring Steps ⑤-⑥

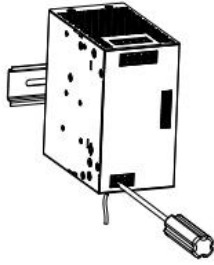

⑤ Turn the Phillips screwdriver to the left to loosen the terminal screws, insert the head of the wire into the bottom of the terminal, and then turn the screwdriver to the right to tighten the terminal screws

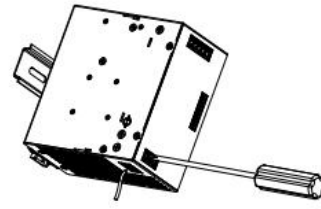

⑥ Turn the Phillips screwdriver to the left to loosen the terminal screw and pull the wire out of the bottom of the terminal