

# PMC Panel Mount Power Supply

## 24V 600W 1 Phase / PMC-24V600W1BA

# PMC



### Highlights & Features

- Universal AC input range
- High PF > 0.99 @ 115Vac
- Power Boost of 200% for 5 seconds
- Meet Surge Immunity IEC 61000-4-5, Level 4 (CM: 4kV, DM: 2kV)
- Built-in fan speed control and fan lock protection
- Wide operating temperature range -20°C to 70°C
- Overvoltage / Overcurrent / Over Temperature / Short Circuit Protections
- Certified according to IEC/EN/UL 62368-1

### Safety Standards



CB Certified for worldwide use

**Model Number:** PMC-24V600W1BA  
**Unit Weight:** 1.60 kg (3.53 lb)  
**Dimensions (L x W x H):** 215 x 120 x 61 mm (8.46 x 4.72 x 2.40 inch)

### General Description

The PMC-24V600W1BA has a power rating of 600W with 24V output voltage. The product features Power Boost of 200% (up to 1200W) for 5 seconds and built-in fan speed control with fan lock protection. The PMC-24V600W1BA accepts the full universal AC input range and have been approved for major safety standards like IEC/EN/UL 60950-1 and IEC/EN/UL 62368-1, EMI according to EN 55011 (Industrial, scientific and medical (ISM) radio-frequency equipment) and EMS according to EN 61000-6-2 (Immunity for industrial environments).

### Model Information

PMC Panel Mount Power Supply

Model Number	Input Voltage Range	Output Voltage	Output Current
PMC-24V600W1BA	85-264Vac (120-370Vdc)	24Vdc	25.0A

### Model Numbering

PM	C –	24V	600W	1	B	A
Panel Mount	Product Type C – Enclosed	Output Voltage	Output Power	Single Phase	With PFC	Front Face connector

# PMC Panel Mount Power Supply

## 24V 600W 1 Phase / PMC-24V600W1BA

### Specifications

#### Input Ratings / Characteristics

Nominal Input Voltage	100-240Vac
Input Voltage Range	85-264Vac (Refer to the Output De-rating VS. Input Voltage graph)
Nominal Input Frequency	50-60Hz
Input Frequency Range	47-63Hz
Nominal DC Input Voltage	142-340Vdc
DC Input Voltage Range*	120-370Vdc (Refer to the Output De-rating VS. Input Voltage graph)
Input Current	< 6.50A @ 115Vac, < 3.20A @ 230Vac
Efficiency at 100% Load	> 86.0% @ 115Vac, > 89.0% @ 230Vac
Max Inrush Current	< 20A @ 115Vac, < 40A @ 230Vac
Power Factor	> 0.99 @ 115Vac, > 0.94 @ 230Vac
Leakage Current	< 1.5mA

\*Fulfills tested conditions

#### Output Ratings / Characteristics

Nominal Output Voltage	24Vdc
Output Voltage Tolerance	± 2% (initial set point tolerance from factory)
Output Voltage Adjustment Range	21.6-26.4Vdc
Output Current	25.0A (continuously operating at 24V) 50.0A (Power Boost for 5 seconds at 24V, refer to the details in the Functions section)
Output Power	600W (continuously operating) 1200W (Power Boost for 5 seconds, refer to the details in the Functions section)
Line Regulation	< 0.4% typ. (@ 115 & 240Vac input, 100% load)
Load Regulation	< 0.625% typ. (@115 & 240Vac input, 100% load)
PARD (20MHz)	< 180mVpp @ 0°C to 50°C, < 240mVpp @ -20°C to 0°C
Rise Time	< 50ms @ 115Vac & 230Vac (100% load)
Start-up Time	< 800ms @ 230Vac (100% load)
Hold-up Time	> 20ms @ 115Vac & 230Vac (100% load)
Dynamic Response (Overshoot & Undershoot O/P Voltage)	± 5% @ 0-50% load and 50-100% load
Start-up with Capacitive Loads	10,000µF Max

# PMC Panel Mount Power Supply

## 24V 600W 1 Phase / PMC-24V600W1BA

### Mechanical

Case Chassis / Cover	SECC	
Dimensions (L x W x H)	215 x 120 x 61 mm (8.46 x 4.72 x 2.40 inch)	
Unit Weight	1.60 kg (3.53 lb)	
Indicator	Green LED (DC OK)	
Cooling System	Forced Cooling (Built-in Fan)	
Terminal	Input	3 Pins (Rated 300V/20A)
	Output	4 Pins (Rated 300V/25A)
Wire	AWG 14-12	
Noise (1 Meter from power supply)	Sound Pressure Level (SPL) < 52dBA	

### Environment

Surrounding Air Temperature	Operating	-20°C to +70°C
	Storage	-20°C to +75°C
Power De-rating	> 50°C de-rate power by 2.5% / °C < 115Vac de-rate power by 0.67% / 1V	
Operating Humidity	20-90% RH	
Operating Altitude	3,000 Meters	
Shock Test (Non-Operating)	IEC 60068-2-27, 30G (300m/S <sup>2</sup> ) for a duration of 18ms, 1 times per direction, 2 times in total	
Vibration (Non-Operating)	IEC 60068-2-6, 10Hz to 150Hz @ 50m/S <sup>2</sup> (5G peak); 20 min per axis for all X, Y, Z direction	
Pollution Degree	2	

### Protections

Overvoltage	27.6-33.6V, SELV Output, Latch-off Mode
Overload / Overcurrent	> 180% of rated load @ $V_{in} \geq 115V_{ac}$ , Hicc-up Mode, Non-Latching (Auto-Recovery)
Over Temperature	< 70°C Surrounding Air Temperature @ 100% load, Latch-off Mode
Short Circuit	Hicc-up Mode, Non-Latching (Auto-Recovery when the fault is removed)
Fan Lock	Latch-off Mode
Protection Against Shock	Class I with PE* connection

\*PE: Primary Earth

### Reliability Data

MTBF	> 300,000 hrs. as per Telcordia SR-332
Expected Cap Life Time	10 years (115Vac & 230Vac, 50% load @ 40°C)

# PMC Panel Mount Power Supply

## 24V 600W 1 Phase / PMC-24V600W1BA

### Safety Standards / Directives

Electrical Safety	SIQ Bauart UL/cUL recognized  CB scheme	EN 60950-1, EN 62368-1 UL 60950-1 and CSA C22.2 No. 60950-1, UL 62368-1 and CSA C22.2 No. 62368-1 IEC 60950-1, IEC 62368-1
CE		In conformance with EMC Directive 2014/30/EU and Low Voltage Directive 2014/35/EU
Galvanic Isolation	Input to Output	3.0KVac
	Input to Ground	1.5KVac
	Output to Ground	0.5KVac

### EMC

Emissions (CE & RE)		Generic Standards: CISPR 32, EN 55032, CISPR 11, EN 55011, FCC Title 47, VCCI*: Class B
Immunity		Generic Standards: EN 55024, EN 61000-6-2
Electrostatic Discharge	IEC 61000-4-2	Level 3 Criteria A <sup>1)</sup> Air Discharge: 8kV Contact Discharge: 6kV
Radiated Field	IEC 61000-4-3	Level 3 Criteria A <sup>1)</sup> 80MHz-1GHz, 10V/M, 80% modulation (1KHz) 1.4GHz-2GHz, 3V/M, 80% modulation (1KHz) 2GHz-2.7GHz, 1V/M, 80% modulation (1KHz)
Electrical Fast Transient / Burst	IEC 61000-4-4	Level 3 Criteria A <sup>1)</sup> 2kV
Surge	IEC 61000-4-5	Level 4 Criteria A <sup>1)</sup> Common Mode <sup>2)</sup> : 4kV Differential Mode <sup>3)</sup> : 2kV
Conducted	IEC 61000-4-6	Level 3 Criteria A <sup>1)</sup> 150kHz-80MHz, 10Vrms
Power Frequency Magnetic Fields	IEC 61000-4-8	Criteria A <sup>1)</sup> 30A/Meter
Voltage Dips	IEC 61000-4-11	100% dip; 1 cycle (20ms); Self Recoverable
Harmonic Current Emission		IEC/EN 61000-3-2, Class A
Voltage Fluctuation and Flicker		IEC/EN 61000-3-3

\*Fulfills tested conditions

- 1) Criteria A: Normal performance within the specification limits
- 2) Asymmetrical: Common mode (Line to earth)
- 3) Symmetrical: Differential mode (Line to line)



# PMC Panel Mount Power Supply

## 24V 600W 1 Phase / PMC-24V600W1BA

### Dimensions

L x W x H: 215 x 120 x 61 mm (8.46 x 4.72 x 2.40 inch)

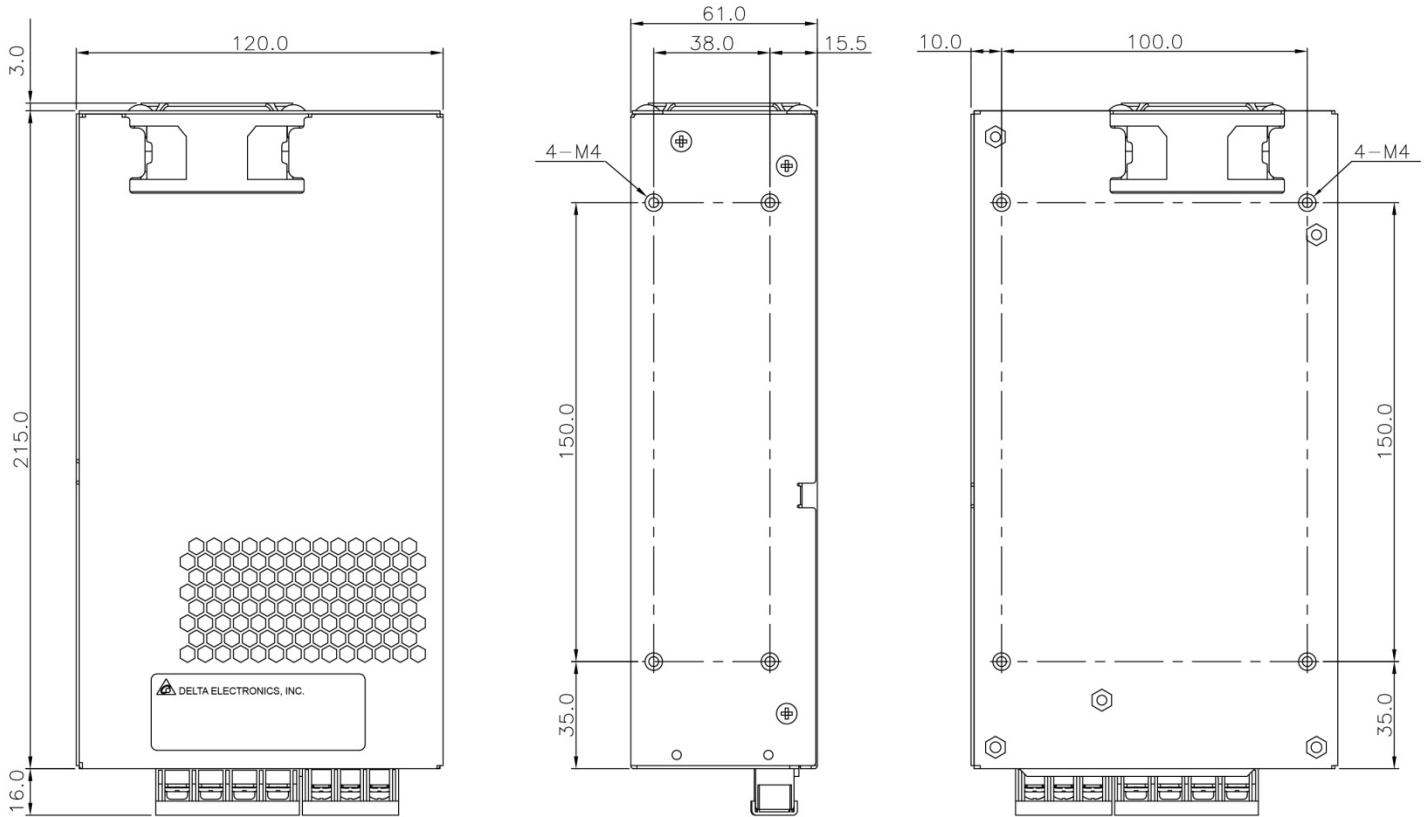

### Engineering Data

#### De-rating

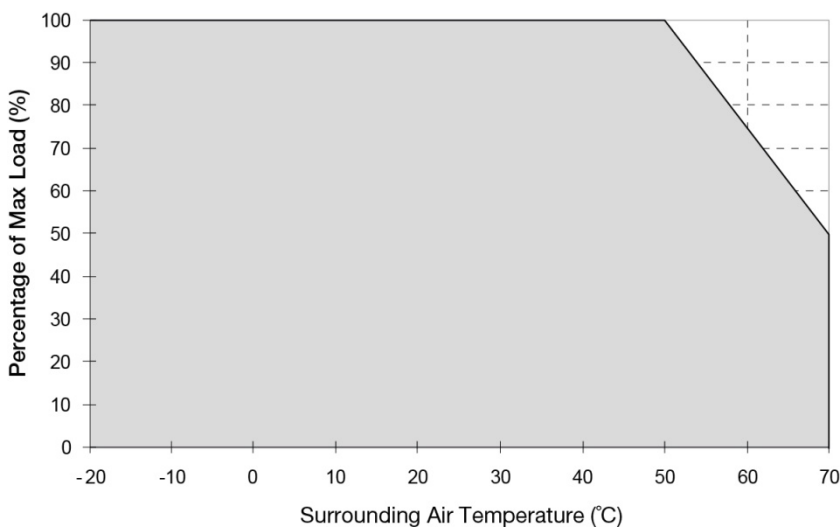

**Fig. 1 De-rating for Vertical and Horizontal Mounting Orientation**  
 > 50°C de-rate power by 2.5% / °C

#### Note

1. Power supply components may degrade, or be damaged, when the power supply is continuously used outside the shaded region, refer to the graph shown in Fig. 1.
2. In the event of a higher operating condition at 100% load, the power supply will run into OTP when the surrounding air temperature is higher than the operating temperature. When activated, the output voltage will go into latch mode until the mains is reapplied and the surrounding air temperature drops to its normal operating temperature.
3. In order for the device to function in the manner intended, it is also necessary to keep a safety distance of 50mm with adjacent units while the device is in operation.
4. Depending on the surrounding air temperature and output load delivered by the power supply, the device can be very hot!
5. If the device has to be mounted in any other orientation, please do not hesitate to contact [info@deltapsu.com](mailto:info@deltapsu.com) for more details.

# PMC Panel Mount Power Supply

## 24V 600W 1 Phase / PMC-24V600W1BA

### Output De-rating VS. Input Voltage

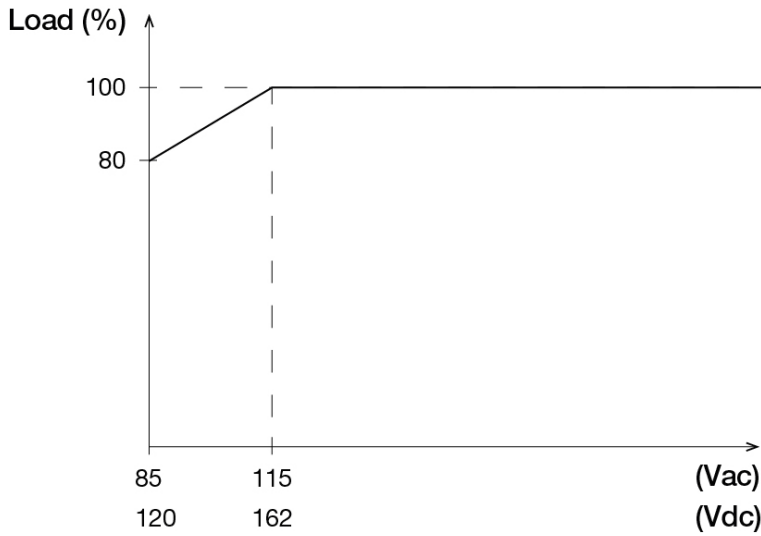

■ Output de-rating is required at 85Vac to 115Vac or 120Vdc to 162Vdc.

### Assembly & Installation

- Ⓐ Mounting holes for power supply assembly onto the mounting surface.  
The power supply shall be mounted on minimum 4 mounting holes using M4 screw minimum 5mm length.
- Ⓑ Input / Output Connector
- Ⓒ This surface belongs to customer's end system or panel where the power supply is mounted.

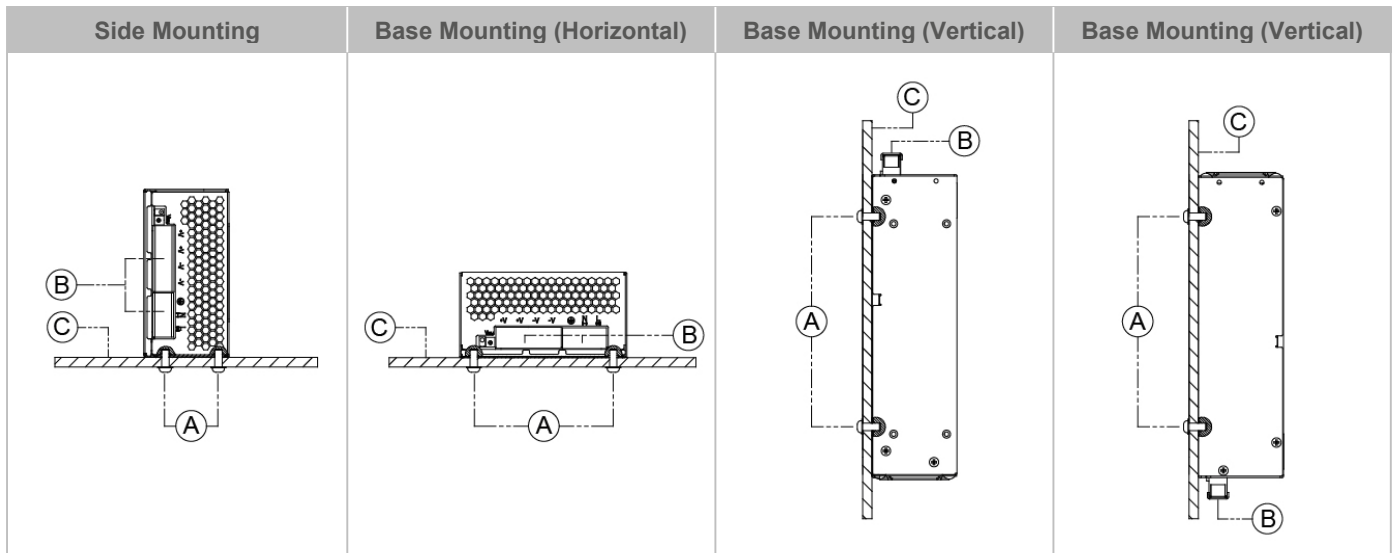

Fig. 2 Mounting Orientation

- Use flexible cable (stranded or solid) of AWG No. 14-12. The torque at the Input connector shall not exceed 11.98Kgf.cm. The torque at the Output connector shall not exceed 16.59Kgf.cm. The insulation stripping length should not exceed 0.275" or 7mm.

# PMC Panel Mount Power Supply

## 24V 600W 1 Phase / PMC-24V600W1BA

### Installation of Mounting Accessories

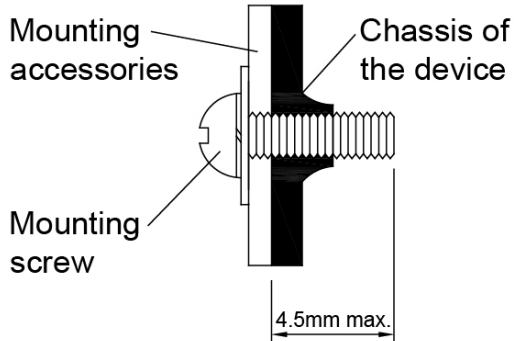

- Only use M4 screw  $\leq 4.5\text{mm}$  through the base mounting holes. This is to keep a safety distance between the screw and internal components.
- Recommended mounting tightening torque: 4~8Kgf.cm.

### Safety Instructions

- To ensure sufficient convection cooling, always maintain a safety distance of  $\geq 50\text{mm}$  from all ventilated surfaces while the device is in operation.
- The device is not recommended to be placed on low thermal conductive surface, for example, plastics.
- Note that the enclosure of the device can become very hot depending on the ambient temperature and load of the power supply. Do not touch the device while it is in operation or immediately after power is turned OFF. Risk of burning!
- Do not touch the terminals while power is being supplied. Risk of electric shock.
- Prevent any foreign metal, particles or conductors from entering the device through the openings during installation. It may cause: Electric shock; Safety Hazard; Fire; Product failure
- Warning: When connecting the device, secure Earth connection before connecting L and N. When disconnecting the device, remove L and N connections before removing the Earth connection.



# PMC Panel Mount Power Supply

## 24V 600W 1 Phase / PMC-24V600W1BA

### Functions

#### Start-up Time

The time required for the output voltage to reach 90% of its set value, after the input voltage is applied.

#### Rise Time

The time required for the output voltage to change from 10% to 90% of its set value.

#### Hold-up Time

Hold up time is the time when the AC input collapses and output voltage retains regulation for a certain period of time. The time required for the output to reach 95% of its set value, after the input voltage is removed.

#### ■ Graph illustrating the Start-up Time, Rise Time, and Hold-up Time

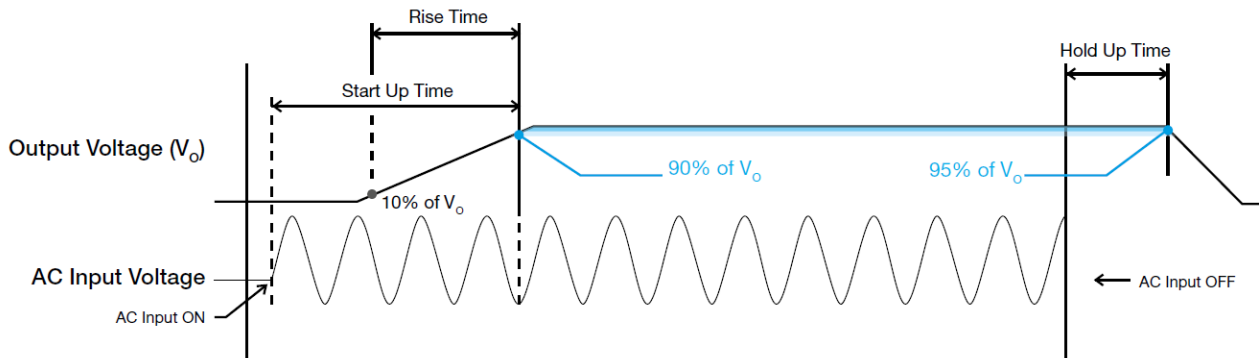

#### Inrush Current

Inrush current is the peak, instantaneous, input current measured and, occurs when the input voltage is first applied. For AC input voltages, the maximum peak value of inrush current will occur during the first half cycle of the applied AC voltage. This peak value decreases exponentially during subsequent cycles of AC voltage.

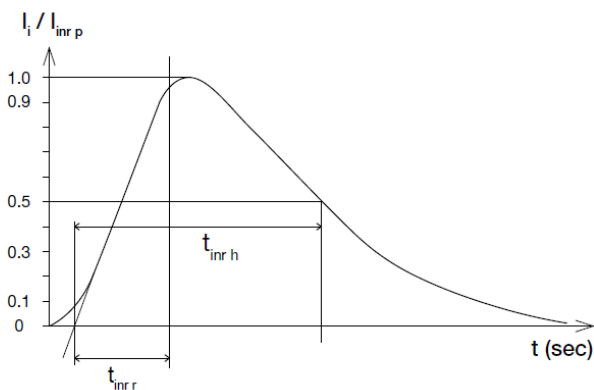

#### Dynamic Response

The power supply output voltage will remain within  $\pm 5\%$  of its steady state value, when subjected to a dynamic load from 5% to 100% of its rated current.

#### ■ 50% duty cycle / 5Hz to 1KHz

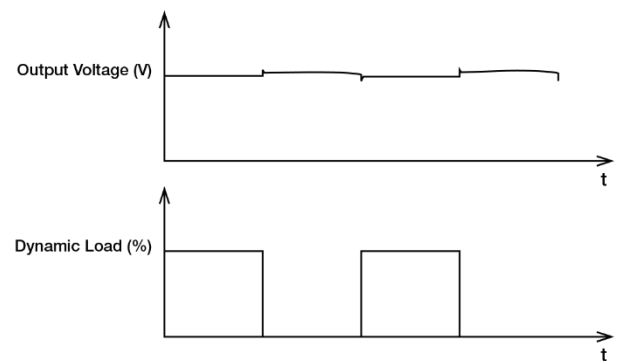

# PMC Panel Mount Power Supply

## 24V 600W 1 Phase / PMC-24V600W1BA

### Power Boost

Power Boost is the reserve power available constantly that allows reliable startup to support sudden and short spike of loads with high inrush current typically during turn on to remove the need of more expensive higher rated power supply unit. After the output has reached its steady state set value, the power supply can support surge loads with a higher short-term power demand up to 200% of maximum rated load (I<sub>o</sub> Max), for a maximum duration of 5 seconds. The Power Boost is also available to repeatedly basis with according to the condition of an average (R.M.S) output power shall not exceed continuous operating condition or refer to duty cycle calculation below.

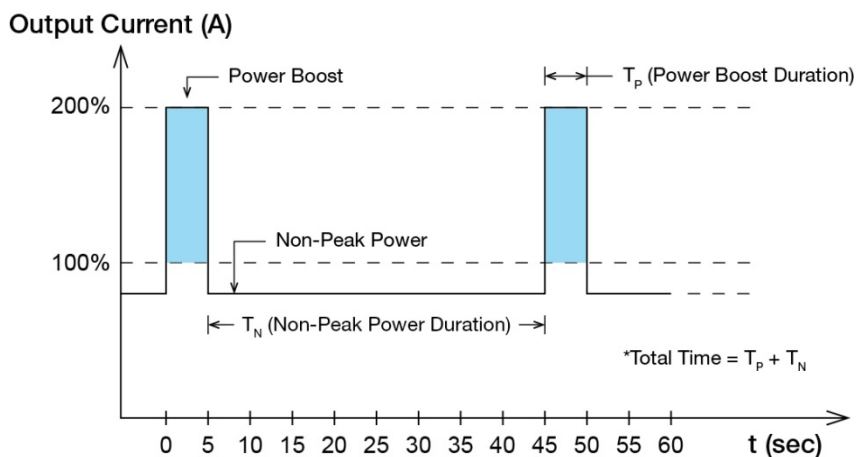

$$Duty\ cycle\ (\%) = \frac{T_p}{Total\ Time}$$

$$Average\ Output\ Power\ (P_{Avg}) = \frac{(Power\ Boost \times T_p) + (Non-Peak\ Power \times T_N)}{Total\ Time}$$

OR

$$Non-Peak\ Power = \frac{(P_{Avg} \times Total\ Time) - (Power\ Boost \times T_p)}{T_N}$$

### ■ An example of Power Boost and Average Output Power

Power Boost	Peak Power (W <sub>P</sub> )	Power Boost Duration (T <sub>P</sub> )	Duty Cycle	Non-Peak Power (W <sub>N</sub> )	Non-Peak Power Duration (T <sub>N</sub> )	Total Time (T)
200%	1200	5 sec	10%	533	45 sec	50 sec
200%	1200	5 sec	35%	277	9.3 sec	14.3 sec
180%	1080	10 sec	20%	480	40 sec	50 sec
180%	1080	10 sec	35%	348	19 sec	29 sec
150%	900	15 sec	30%	471	35 sec	50 sec
150%	900	15 sec	35%	438	28 sec	43 sec
124%	744	20 sec	40%	504	30 sec	50 sec

It is not recommended to prolong the duration of Power Boost to be longer than the specified duty cycle calculation, this may cause damage to the PSU.

# PMC Panel Mount Power Supply

## 24V 600W 1 Phase / PMC-24V600W1BA

### Overload & Overcurrent Protections

The power supply's Overload (OLP) and Overcurrent (OCP) Protections will be activated when output current exceeds 180% of  $I_o$  (Max load). In such occurrence, the  $V_o$  will start to droop and once the power supply has reached its maximum power limit, the protection is activated and the power supply will go into "Hiccup mode" (Auto-Recovery). The power supply will recover once the fault condition of the OLP and OCP is removed and  $I_o$  is back within the specifications.

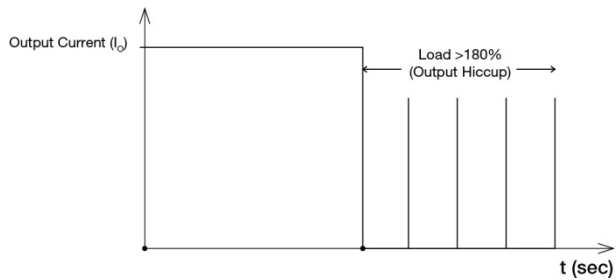

It is not recommended to prolong the duration of  $I_o$  when it is <180% but >100%, since it may cause damage to the PSU.

### Short Circuit Protection

The power supply's output OLP/OCP function also provides protection against short circuits. When a short circuit is applied, the output current will operate in "Hiccup mode", as shown in the illustration in the OLP/OCP section on this page. The power supply will return to normal operation after the short circuit is removed.

### Overvoltage Protection

The power supply's overvoltage circuit will be activated when its internal feedback circuit fails. The output voltage shall not exceed its specifications defined on Page 3 under "Protections".

Overvoltage Protection (OVP) is Latch Mode.

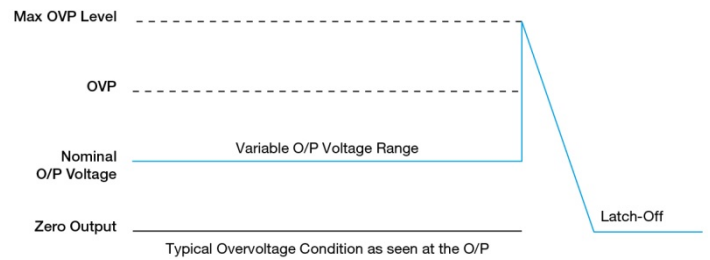

### Over Temperature Protection

As mentioned above, the power supply also has Over Temperature Protection (OTP). In the event of a higher operating temperature at 100% load, the power supply will run into OTP when the operating temperature is beyond what is recommended in the de-rating graph. When activated, the output voltage will go into latch mode until the mains is reapplied and the temperature drops to its normal operating temperature as recommended in the de-rating graph.

# PMC Panel Mount Power Supply

## 24V 600W 1 Phase / PMC-24V600W1BA

### Operating Mode

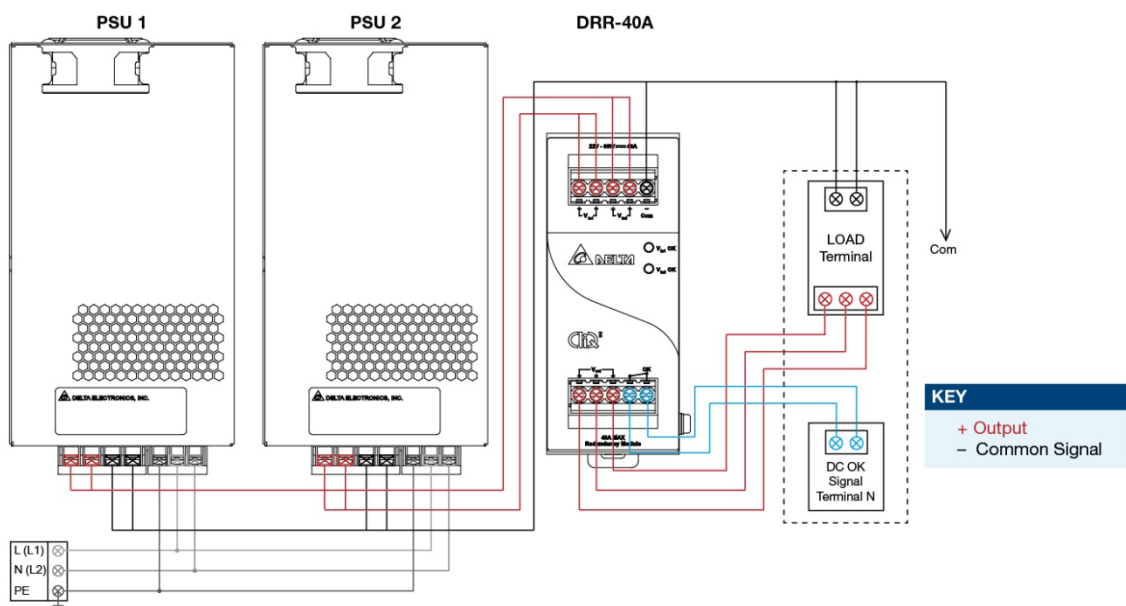

Fig. 3 Redundancy / Parallel Operation Connection Diagram

#### ■ Redundancy Operation

In order to ensure proper redundancy operation for the power supply unit (PSU), ensure that the output voltage difference between the two units is kept at 0.45~0.50V for 24V supplies. Follow simple steps given below to verify:

##### Step 1.

Measure output voltage of PSU 1 and PSU 2. If PSU 1 is the master unit, then  $V_o$  of PSU 1 must be higher than PSU 2. In order to set the output voltage, connect the power supply to 50% load and set the PSU 1 and PSU 2 output voltage.

##### Step 2.

Connect the right DRR module, 40A as per the system requirement to the power supply units PSU 1 and PSU 2 at  $V_{in 1}$  &  $V_{in 2}$  respectively.

##### Step 3.

Connect the system load from  $V_{out}$ . Please note that output voltage  $V_{out}$  from DRR module will be =  $V_o$  (output voltage of power supply) -  $V_{drop}^*$  (in DRR module).

#### ■ Parallel Operation

These DRR modules can also be used for Parallel function in order to increase the output power by N+1 (e.g. 2.5A + 2.5A = 5A or 2.5A + 2.5A + 2.5A = 7.5A) or current sharing, and thus increasing the power supply and system reliability. Though the PMC-24V600W1BA is not designed for current sharing, a good current sharing between two power supplies can be achieved by following simple steps as below (Refer to Fig. 3 for the Connection Diagram).

##### Step 1.

Set output load condition for both supplies at 50% and measure the output voltages.

##### Step 2.

Adjust output voltages to the same level or within  $\pm 25mV$  difference.

##### Step 3.

Connect PSU 1 and PSU 2 with the DRR-40A module and measure at  $V_{in 1}$  &  $V_{in 2}$  to verify the voltage difference. Ensure the voltages are within  $\pm 25mV$ .

##### Step 4.

Output voltage from DRR module  $V_{out}$  will be =  $V_o$  (output voltage of power supply) -  $V_{drop}^*$  (in DRR module).

\* $V_{drop}$  will vary from 0.60V to 0.90V (Typical 0.65V) depending on the load current and surrounding air temperature.

# PMC Panel Mount Power Supply

## 24V 600W 1 Phase / PMC-24V600W1BA

### Others

PFC – Norm EN 61000-3-2

#### Line Current Harmonic content

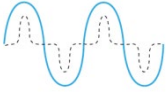

Typically, the input current waveform is not sinusoidal due to the periodical peak charging of the input capacitor. In industrial environment, complying with EN 61000-3-2 is only necessary under special conditions. Complying to this standard can have some technical drawbacks, such as lower efficiency as well as some commercial aspects such as higher purchasing costs. Frequently, the user does not profit from fulfilling this standard, therefore, it is important to know whether it is mandatory to meet this standard for a specific application.

### Attention

Delta provides all information in the datasheets on an “AS IS” basis and does not offer any kind of warranty through the information for using the product. In the event of any discrepancy between the information in the catalog and datasheets, the datasheets shall prevail (please refer to [www.DeltaPSU.com](http://www.DeltaPSU.com) for the latest datasheets information). Delta shall have no liability of indemnification for any claim or action arising from any error for the provided information in the datasheets. Customer shall take its responsibility for evaluation of using the product before placing an order with Delta.

Delta reserves the right to make changes to the information described in the datasheets without notice.