

Sync DIN Rail Power Supply

24V 30W 1 Phase (NEC Class 2) / DRS-24V30W1AZ

sync



Highlights & Features

- Ultra compact size and galvanic isolation up to 3.0kVac between input to output
- Universal AC input voltage and full power from -10°C to +55°C operation
- Up to 88.0% efficiency
- Low earth leakage current < 0.5mA @ 240Vac
- NEC Class 2 / Limited Power Source (LPS) certified
- Overvoltage / Overcurrent / Over Temperature Protections
- Meet Surge Immunity IEC 61000-4-5, Level 4 (CM: 4kV, DM: 2kV)

Safety Standards



CB Certified for worldwide use

Model Number: DRS-24V30W1AZ
Unit Weight: 0.10 kg (0.22 lb)
Dimensions (L x W x D): 75 x 21 x 89.5 mm (2.95 x 0.83 x 3.52 inch)

General Description

The ultra-compact and competitively priced Delta Sync DIN rail power supply series is designed for industrial applications requiring highly reliable power supply within a tight space. The Sync series operates with universal AC input range and offers full power up to 55°C. All models in the series are certified according to IEC/EN/UL 60950-1 & IEC/EN/UL 62368-1 for Information Technology Equipment (ITE) and UL 508 Industrial Control Equipment (ICE). The series is also fully compliant with RoHS Directive for environmental protection. NEC Class 2 and Limited Power Source (LPS) approvals are available for this product.

Model Information

Sync DIN Rail Power Supply

Model Number	Input Voltage Range	Rated Output Voltage	Rated Output Current
DRS-24V30W1AZ	85-264Vac	24Vdc	1.25A

Model Numbering

DR	S –	24V	30W	1	A	Z
DIN Rail	Product Series S – Sync Series	Output Voltage	Output Power	Single Phase	No PFC	Without DC OK Relay Contact

Sync DIN Rail Power Supply

24V 30W 1 Phase (NEC Class 2) / DRS-24V30W1AZ

Specifications

Input Ratings / Characteristics

Nominal Input Voltage	100-240Vac	
Input Voltage Range	85-264Vac	
Nominal Input Frequency	50-60Hz	
Input Frequency Range	47-63Hz	
Input Current	< 0.80A @ 115Vac, < 0.40A @ 230Vac	
Efficiency at 100% Load	88.0% typ. @ 230Vac	
Max Power Dissipation	No load	< 0.5W @ 115Vac & 230Vac
	100% load	< 2.5W @ 115Vac & 230Vac
Max Inrush Current (Cold Start)	< 30A @ 115Vac, < 60A @ 230Vac	
Leakage Current	< 0.5mA @ 240Vac	

Output Ratings / Characteristics*

Nominal Output Voltage	24Vdc
Factory Set point Tolerance	24Vdc \pm 1%
Output Voltage Adjustment Range	21.6-26.4Vdc
Output Current	1.25A (30W max.)
Output Power	30W
Line Regulation	< 1% typ. (@ 85-264Vac, 100% load)
Load Regulation	< 1% typ. (@ 85-264Vac, 0-100% load)
PARD** (20MHz)	< 150mVpp @ > 0°C to 70°C < 500mVpp @ 0°C to -20°C
Rise Time	< 50ms @ nominal input (100% load)
Start-up Time	< 3,000ms @ 115Vac (100% load) < 1,600ms @ 230Vac (100% load)
Hold-up Time	> 20ms @ 230Vac (100% load)
Dynamic Response (Overshoot & Undershoot O/P Voltage)	\pm 5% @ 85-264Vac input, 0-50% load, 50-100% (Slew Rate: 0.1A/ μ s, 50% duty cycle @ 5Hz to 100Hz)
Start-up with Capacitive Loads	3,000 μ F Max

*For power de-rating from < -10°C to -20°C, and 55°C to 70°C, see power de-rating on page 3.

**PARD is measured with an AC coupling mode, 5cm wires, and in parallel with 0.1 μ F ceramic capacitor & 47 μ F electrolytic capacitor.

Sync DIN Rail Power Supply

24V 30W 1 Phase (NEC Class 2) / DRS-24V30W1AZ

Mechanical

Case Cover / Chassis	Plastic	
Dimensions (L x W x D)	75 x 21 x 89.5 mm (2.95 x 0.83 x 3.52 inch)	
Unit Weight	0.10 kg (0.22 lb)	
LED Indicator	Green LED	DC OK
Cooling System	Convection	
Terminal	Input	3 Pins (Rated 300V/16A)
	Output	2 Pins (Rated 300V/16A)
Wire	Input / Output	AWG 26-12
Mounting Rail	Standard TS35 DIN Rail in accordance with EN 60715	
Noise (1 Meter from power supply)	Sound Pressure Level (SPL) < 25dBA	

Environment

Surrounding Air Temperature	Operating	-20°C to +70°C
	Storage	-40°C to +85°C
Power De-rating	Temperature	-10°C to -20°C de-rate power by 5% / °C > 55°C de-rate power by 3.33% / °C
Operating Humidity	5 to 95% RH (Non-Condensing)	
Operating Altitude	0 to 2,000 Meters (6,560 ft.)	
Shock Test	Non-Operating	IEC60068-2-27, Half Sine Wave: 50G for a duration of 11ms; 3 times per direction
	Operating	IEC 60068-2-27, Half Sine Wave: 10G for a duration of 11ms, 1 shock for X direction
Vibration	Non-Operating	IEC 60068-2-6, Random: 5-500Hz; 2.09Grms, 20 min per axis for all X, Y, Z directions
	Operating	IEC 60068-2-6, Sine Wave: 10-500Hz @ 19.6m/S ² (2G peak); 10 min per cycle, 60 min for X direction
Over Voltage Category	II	
Pollution Degree	2	

Protections

Overvoltage	< 34.8V, SELV Output, Auto-Recovery
Overload / Overcurrent	110-150% of rated load current, Hiccup Mode, Non-Latching (Auto-Recovery when the fault is removed)
Over Temperature	Auto-Recovery
Short Circuit	Auto-Recovery when the fault is removed
Internal Fuse at L pin	T3.15A
Degree of Protection	IP20
Protection Against Shock	Class I with PE* connection

*PE: Primary Earth

Sync DIN Rail Power Supply

24V 30W 1 Phase (NEC Class 2) / DRS-24V30W1AZ

Reliability Data

MTBF	Telcordia SR-332	> 700,000 hrs.	I/P: 100Vac, O/P: 100% load, Ta: 25°C
Expected Cap Life Time	10 years (230Vac, 50% load @ 40°C)		

Safety Standards / Directives

Safety Entry Low Voltage		SELV (EN 60950)
Electrical Safety	TUV Bauart	EN 60950-1, EN 62368-1
	UL/cUL recognized	UL 60950-1, CSA C22.2 No. 60950-1 (File No. E131881) UL 62368-1, CSA C22.2 No. 62368-1 (File No. E131881)
	CB Scheme	IEC 60950-1, IEC 62368-1 Limited Power Source (LPS)
Industrial Control Equipment	UL/cUL listed	UL 508 and CSA C22.2 No. 107.1-01 (File No. E338991)
Class 2 Power Supply	UL/cUL recognized	UL 60950-1, CSA C22.2 No. 60950-1 (File No. E131881) UL 62368-1, CSA C22.2 No. 62368-1 (File No. E131881)
CCC		GB9254, GB17625.1 and GB4943.1
CE		In conformance with EMC Directive 2014/30/EU and Low Voltage Directive 2014/35/EU
UKCA		In conformance with 2016 No. 1101. The Electrical Equipment (Safety) Regulations 2016 and 2016 No. 1091 The Electromagnetic Compatibility Regulations 2016
Galvanic Isolation	Input to Output	3.0KVac
	Input to Ground	1.5KVac
	Output to Ground	0.5KVac

EMC

Emissions (CE & RE)		Generic Standards: EN 61000-6-3, EN 61000-6-4 CISPR 32, EN 55032, FCC Title 47: Class B
Immunity		Generic Standards: EN 55024
Electrostatic Discharge	IEC 61000-4-2	Criteria A ¹⁾ Air Discharge: 8kV(Level 3) Contact Discharge: 8kV(Level 4)
Radiated Field	IEC 61000-4-3	Level 3 Criteria A ¹⁾ 80MHz-1GHz, 10V/M with 1kHz tone / 80% modulation
Electrical Fast Transient / Burst	IEC 61000-4-4	Level 4 Criteria A ¹⁾ 4kV
Surge	IEC 61000-4-5	Level 4 Criteria A ¹⁾ Common Mode ²⁾ : 4kV Differential Mode ³⁾ : 2kV
Conducted	IEC 61000-4-6	Level 3 Criteria A ¹⁾ 150kHz-80MHz, 10Vrms
Power Frequency Magnetic Fields	IEC 61000-4-8	Criteria A ¹⁾ 1A/Meter
Voltage Dips and Interruptions	IEC 61000-4-11	> 100% dip; 1 cycle (20ms)
Voltage Fluctuation and Flicker		IEC/EN 61000-3-3

1) Criteria A: Normal performance within the specification limits

2) Asymmetrical: Common mode (Line to earth)

3) Symmetrical: Differential mode (Line to line)

Sync DIN Rail Power Supply

24V 30W 1 Phase (NEC Class 2) / DRS-24V30W1AZ

Block Diagram

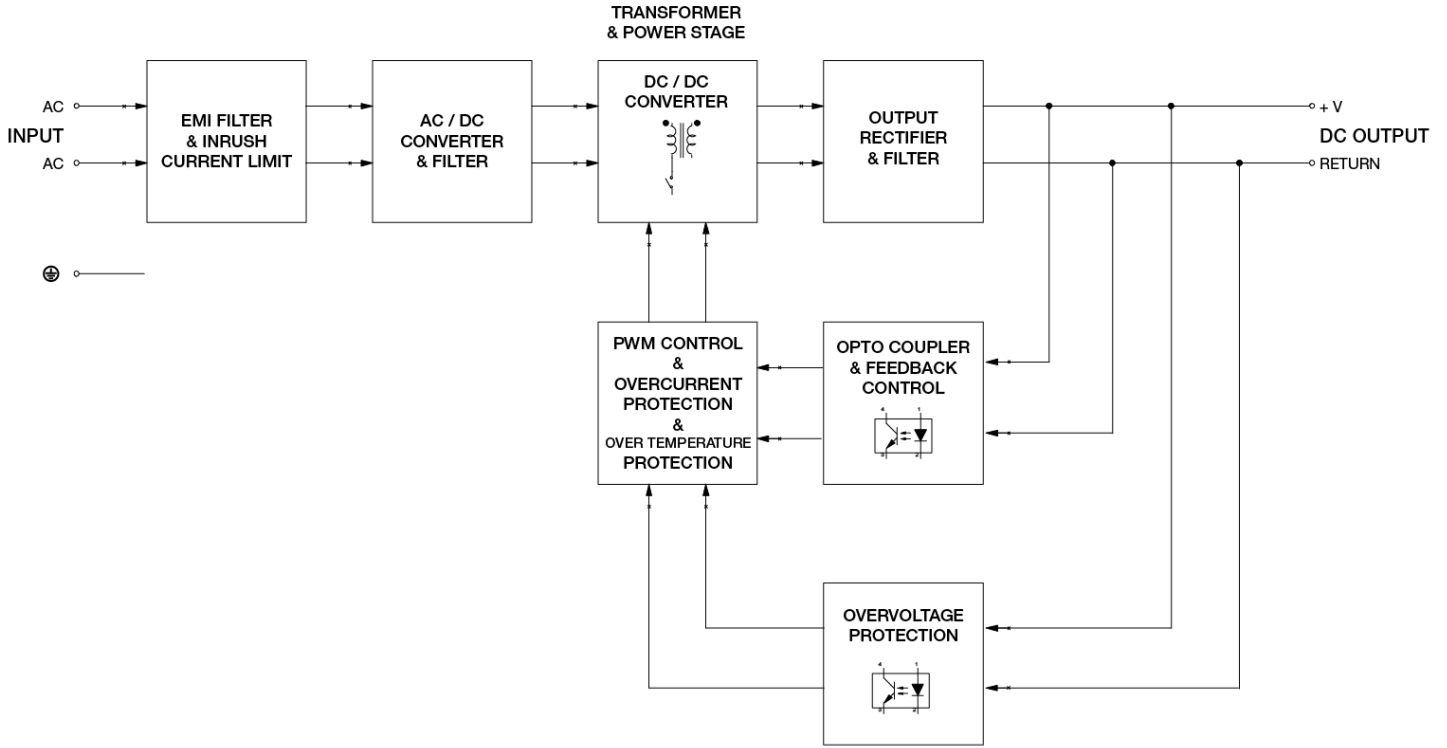

Device Description

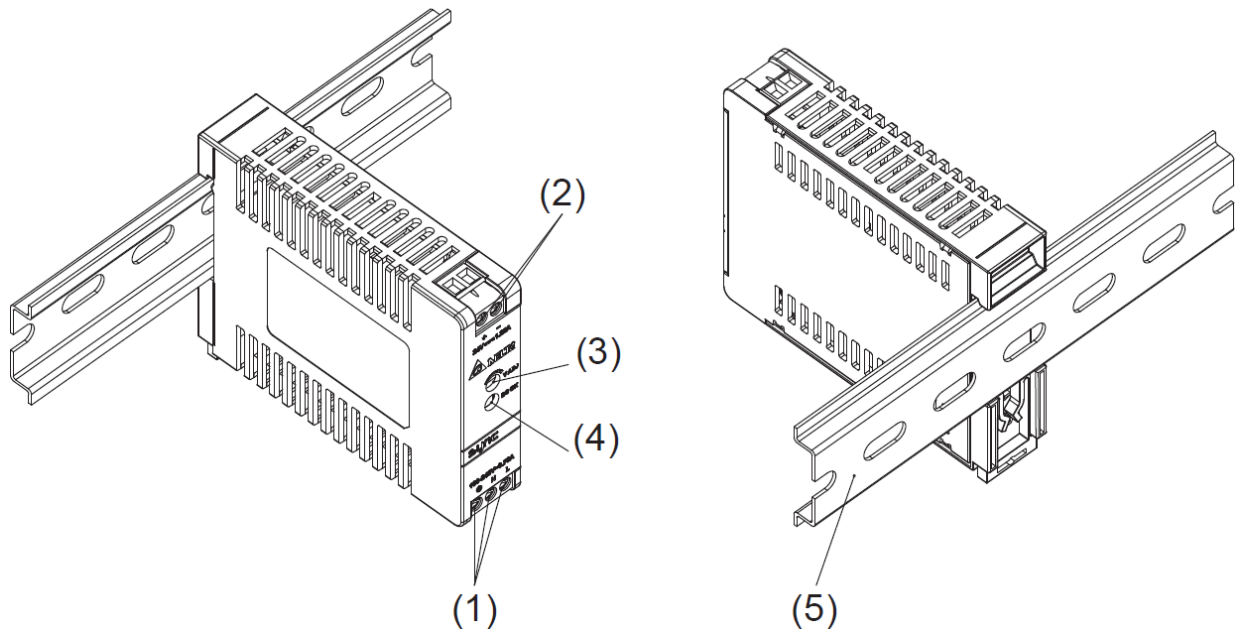

- 1) Input terminal block connector
- 2) Output terminal block connector
- 3) DC voltage adjustment potentiometer
- 4) DC OK LED (Green)
- 5) Universal mounting system

Sync DIN Rail Power Supply

24V 30W 1 Phase (NEC Class 2) / DRS-24V30W1AZ

Dimensions

L x W x D: 75 x 21 x 89.5 mm [2.95 x 0.83 x 3.52 inch]

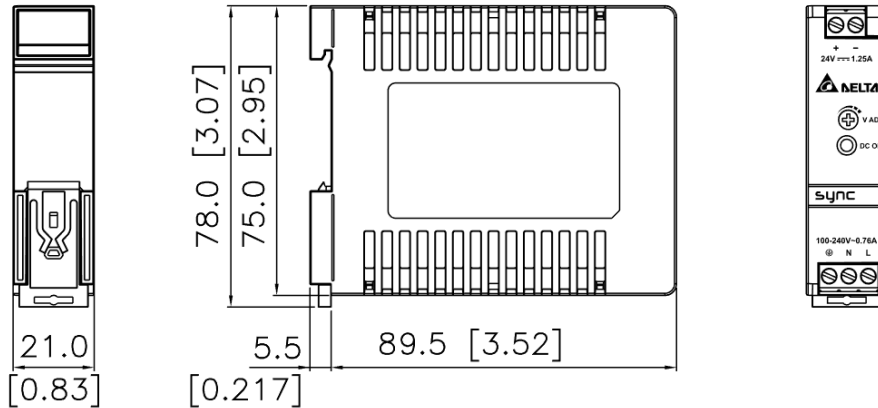

Engineering Data

Output Load De-rating VS Surrounding Air Temperature

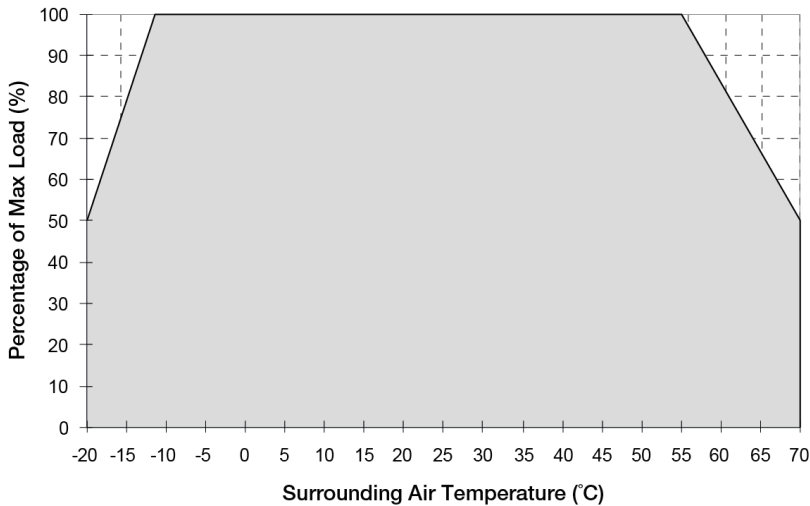

Fig. 1 De-rating for Vertical Mounting Orientation

-10°C to -20°C de-rate power by 5% / °C
 > 55°C de-rate power by 3.33% / °C

Note

1. Power supply components may degrade, or be damaged, when the power supply is continuously used outside the shaded region, refer to the graph shown in Fig. 1.
2. If the output capacity is not reduced when the surrounding air temperature exceeds its specification as defined on Page 3 under "Environment", the device will run into Over Temperature Protection. When activated, the output voltage will go into bouncing mode and will recover when the surrounding air temperature is lowered or the load is reduced as far as necessary to keep the device in working condition.
3. In order for the device to function in the manner intended, it is also necessary to keep a safety distance as recommended in the safety instructions while the device is in operation.
4. Depending on the surrounding air temperature and output load delivered by the power supply, the device can be very hot!
5. If the device has to be mounted in any other orientation, please contact info@deltapsu.com for more details.

Sync DIN Rail Power Supply

24V 30W 1 Phase (NEC Class 2) / DRS-24V30W1AZ

Output Load De-rating VS Input Voltage

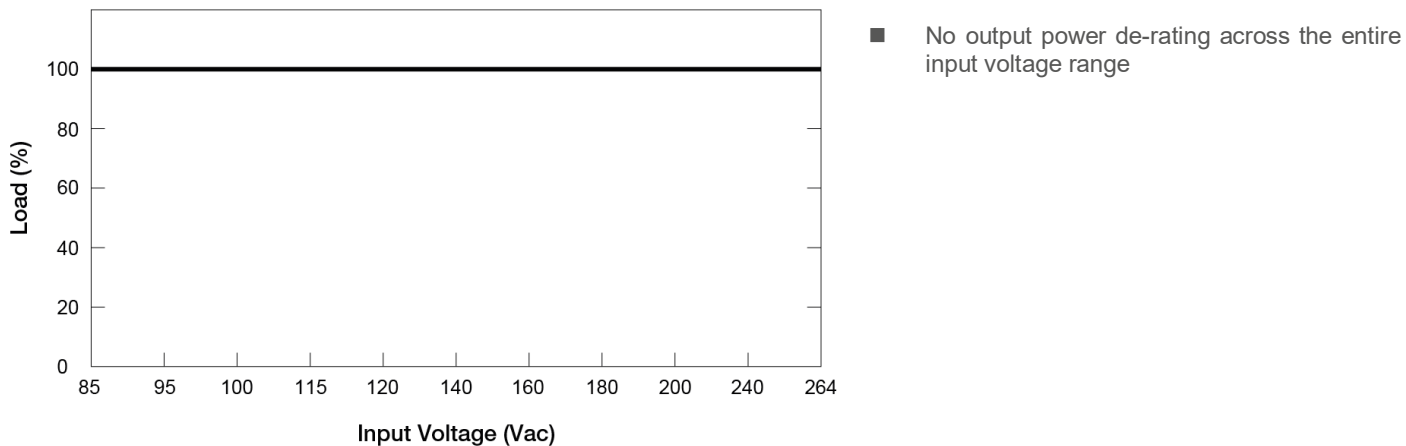

Assembly & Installation

The power supply unit (PSU) can be mounted on 35 mm (1.38 inch) DIN rails in accordance with EN60715. The device should be installed with input terminal block at the bottom.

Each device is delivered ready to install.

Mounting

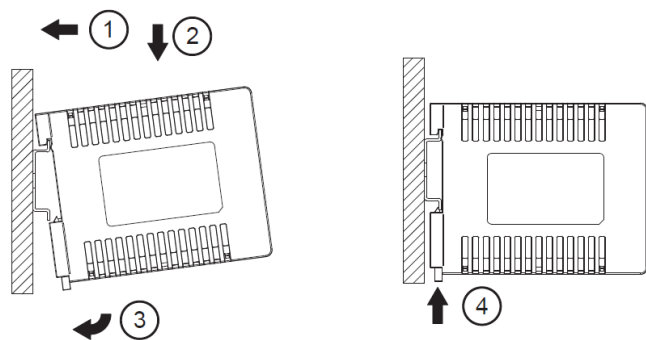

Fig. 2.1 Mounting

Snap on the DIN rail as shown in Fig. 2.1:

1. Tilt the unit upwards and insert it onto the DIN rail.
2. Push downwards until stopped.
3. Press against the bottom front side for locking.
4. Shake the unit slightly to ensure that it is secured.

Dismounting

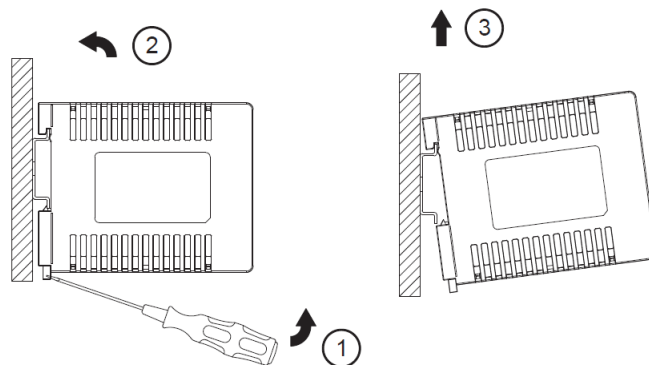

Fig. 2.2 Dismounting

To uninstall, pull or slide down the latch with screw driver as shown in Fig. 2.2. Then slide the power supply unit (PSU) in the opposite direction, release the latch and pull out the power supply unit (PSU) from the rail.

Sync DIN Rail Power Supply

24V 30W 1 Phase (NEC Class 2) / DRS-24V30W1AZ

Safety Instructions

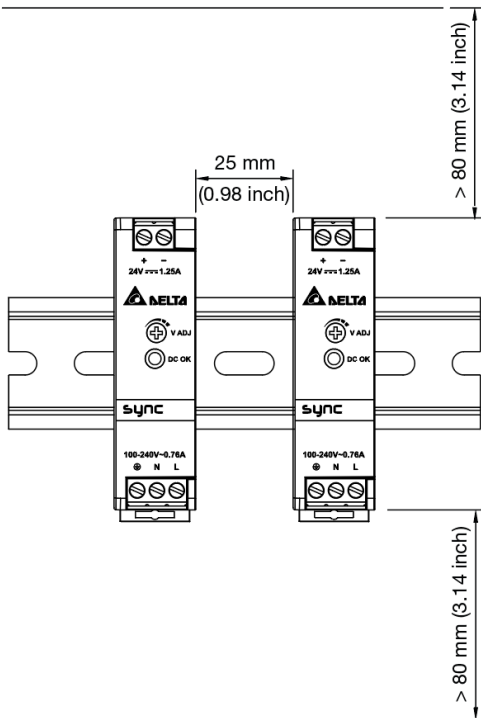

- ALWAYS switch mains of input power OFF before connecting and disconnecting the input voltage to the unit. If mains are not turned OFF, there is risk of explosion / severe damage.
- To guarantee sufficient convection cooling, keep a distance of 80 mm (3.14 inch) above and below the device as well as a lateral distance of 25 mm (0.98 inch) to other units.
- Note that the enclosure of the device can become very hot depending on the surrounding air temperature and load of the power supply. Risk of burns!
- The main power must be turned off before connecting or disconnecting the wires to the terminals!
- DO NOT insert any objects into the device.
- Dangerous voltages present for at least 5 minutes after disconnecting all sources of power.
- The power supplies unit should be installed in minimum IP54 rated enclosure.
- The power supplies are built in units and must be installed in a cabinet or room (condensation free environment and indoor location) that is relatively free of conductive contaminants.

Functions

- Graph illustrating the Start-up Time, Rise Time, and Hold-up Time

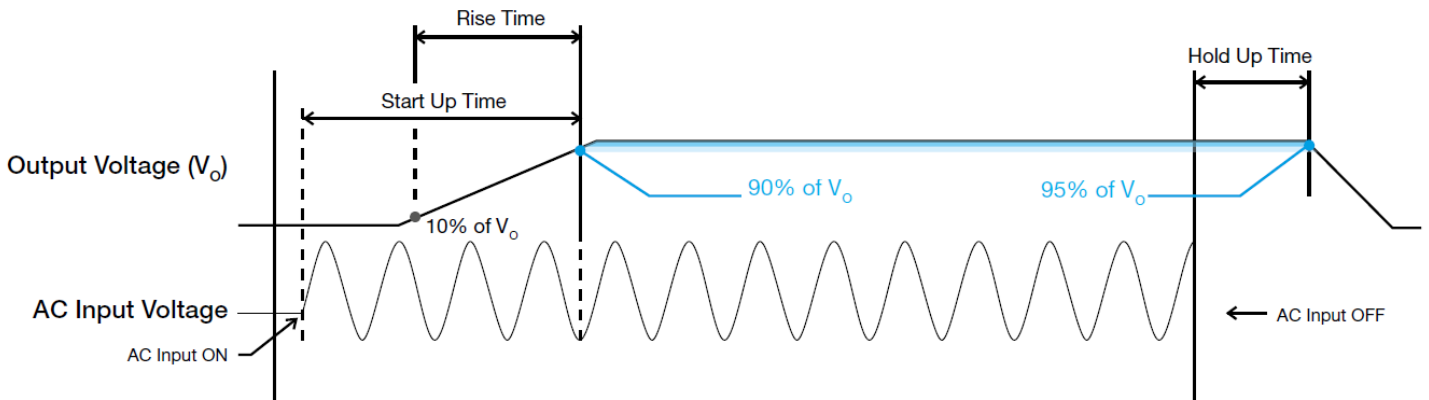

Start-up Time

The time required for the output voltage to reach 90% of its final steady state set value, after the input voltage is applied.

Rise Time

The time required for the output voltage to change from 10% to 90% of its final steady state set value.

Hold-up Time

Time between the collapse of the AC input voltage, and the output falling to 95% of its steady state set value.

Sync DIN Rail Power Supply

24V 30W 1 Phase (NEC Class 2) / DRS-24V30W1AZ

Inrush Current

Inrush current is the peak, instantaneous, input current measured and, occurs when the input voltage is first applied. For AC input voltages, the maximum peak value of inrush current will occur during the first half cycle of the applied AC voltage. This peak value decreases exponentially during subsequent cycles of AC voltage.

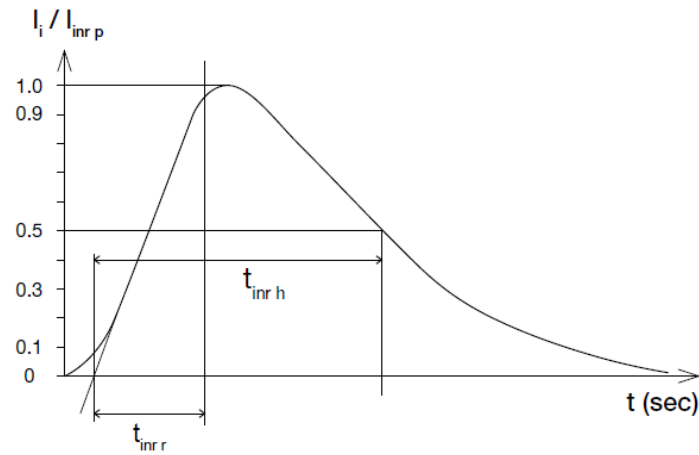

Dynamic Response

The power supply output voltage will remain within $\pm 5\%$ of its steady state value, when subjected to a dynamic load from 10% to 100% of its rated current.

■ 50% duty cycle / 5Hz to 100Hz

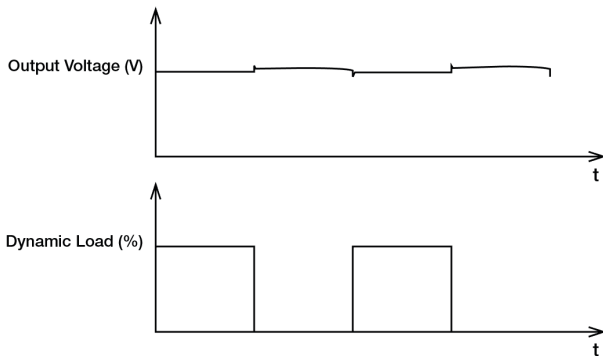

Overvoltage Protection (Auto-Recovery)

The power supply's overvoltage circuit will be activated when its internal feedback circuit fails. The output voltage shall not exceed its specifications defined on Page 3 under "Protections".

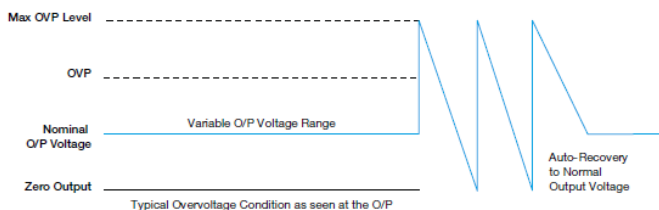

Overload & Overcurrent Protections (Auto-Recovery)

The power supply's Overload (OLP) and Over current (OCP) Protections will be activated when output current (I_o) exceeds its specification as defined on Page 3 under "Protections". In such occurrence, once the power supply has reached its maximum power limit, the protection is activated and the power supply will go into "Hiccup mode" (Auto-Recovery). The power supply will recover once the fault condition of the OLP and OCP is removed and I_o is back within the specifications.

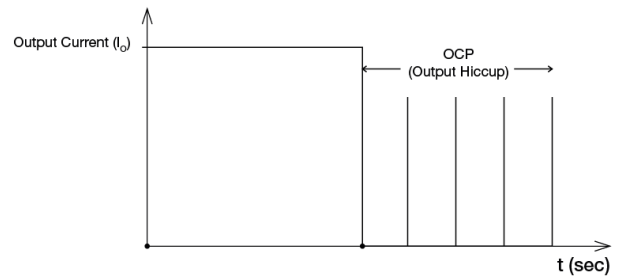

It is not recommended to prolong the duration of I_o when it is less than OLP/OCP point, but greater than 100%, since it may cause damage to the PSU.

Over Temperature Protection (Auto-Recovery)

As described in load de-rating section, the power supply also has Over Temperature Protection (OTP). In the event of a higher operating temperature at 100% load, the power supply will run into OTP when the operating temperature is beyond what is recommended in the de-rating graph. When activated, the output voltage will go into bouncing mode until the temperature drops to its normal operating temperature as recommended in the de-rating graph.

Short Circuit Protection (Auto-Recovery)

The power supply's output OLP/OCP function also provides protection against short circuits. When a short circuit is applied, the output current will operate in "Hiccup mode", as shown in the illustration in the OLP/OCP section on this page. The power supply will return to normal operation after the short circuit is removed.

Sync DIN Rail Power Supply

24V 30W 1 Phase (NEC Class 2) / DRS-24V30W1AZ

Operating Mode

■ Redundancy Operation

In order to ensure proper redundant operation for the power supply units (PSUs), the output voltage difference between the two units must be kept at 0.45~0.50V for these 24V supplies. Follow simple steps given below to set them up for the redundant operation:

Step 1.

Measure output voltage of PSU 1 and PSU 2. If PSU 1 is the master unit, then V_O of PSU 1 must be higher than PSU 2. In order to set the output voltage, individually connect each power supply to 50% of rated load at any line voltage from 85-264Vac, and set the PSU 1 and PSU 2 output voltage.

Step 2.

Connect the power supply units PSU 1 and PSU 2 to $V_{in} 1$ & $V_{in} 2$, respectively, of the DRR-20N (or 20A) module shown on the right of above diagram.

Step 3.

Connect the system load from V_{out} . Please note that output voltage V_{out} from DRR module will be $= V_O$ (output voltage of power supply) $- V_{drop}^*$ (in DRR module).

* V_{drop} will vary from 0.60V to 0.90V (Typical 0.65V) depending on the load current and surrounding air temperature.

■ Parallel Operation

The power supply units (PSUs) can also be used for parallel operation in order to increase the output power. The difference in output voltage between the two units must be kept to within 25mV of each other. This difference must be verified with the same output load connected independently to each unit.

Parameters such as EMI, inrush current, leakage current, PARD, start up time will be different from those on the datasheet, when two units are connected in parallel. The user will need to verify that any differences will still allow the two power supplies connected in parallel will work properly in their product/application.

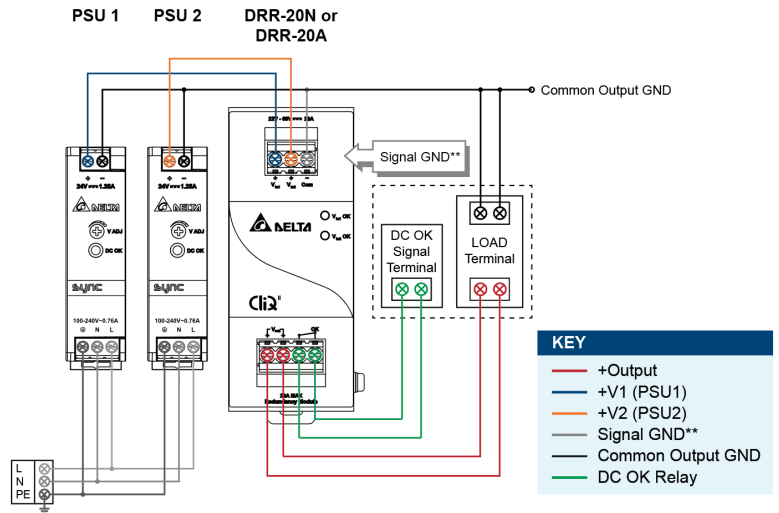

**The Signal GND in the DRR module is for the built-in LED and DC OK signals. The Output GND terminals from the two PSU's do not need to be connected to the Signal GND terminal.

Fig. 3 Redundant Operation Connection Diagram

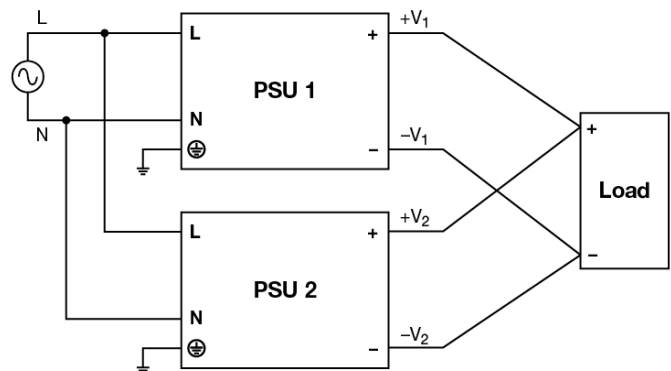

Fig. 4 Parallel Operation Connection Diagram

Sync DIN Rail Power Supply

24V 30W 1 Phase (NEC Class 2) / DRS-24V30W1AZ

Others

Attention

Delta provides all information in the datasheets on an "AS IS" basis and does not offer any kind of warranty through the information for using the product. In the event of any discrepancy between the information in the catalog and datasheets, the datasheets shall prevail (please refer to www.DeltaPSU.com for the latest datasheets information). Delta shall have no liability of indemnification for any claim or action arising from any error for the provided information in the datasheets. Customer shall take its responsibility for evaluation of using the product before placing an order with Delta.

Delta reserves the right to make changes to the information described in the datasheets without notice.

Manufacturer and Authorized Representatives Information

Manufacturer

Thailand

Delta Electronics (Thailand) PCL.
909 Pattana 1 Rd., Muang, Samutprakarn, 10280 Thailand

Taiwan

Delta Electronics, Inc.
3 Tungyuan Road, Chungli Industrial Zone, Taoyuan County
32063, Taiwan

Authorized Representatives

The Netherlands

Delta Greentech (Netherlands) B.V.
Zandsteen 15, 2132 MZ Hoofddorp, The Netherlands

United Kingdom

Delta Electronics Europe Limited
1 Redwood Court, Peel Park Campus,
East Kilbride, Glasgow, G74 5PF, United Kingdom