

CliQ II Buffer Module

24V 40A / DRB-24V040ABN



Highlights & Features

- Minimum buffering time of 200ms @ 24V/40A
- Flexible operating buffering voltage modes:
 - Fixed mode at 22Vdc
 - Dynamic mode for $V_{in} - 1V$
- Supports parallel connection to extend buffering time
- Conformal coating on PCBAs to protect against common dust and chemical pollutants

Safety Standards



CB Certified for worldwide use

Model Number: DRB-24V040ABN
Unit Weight: 0.90 kg (1.98 lb)
Dimensions (L x W x D): 121 x 70 x 120.1 mm
 (4.76 x 2.76 x 4.73 inch)

General Description

Delta's CliQ II buffer module offers the most widely used output voltage of 24V and a minimum buffering time of 200ms at 40A in wide input range from 22.8Vdc to 28.8Vdc. The buffer module utilizes maintenance-free electrolytic capacitors to store energy, thus eliminates the need of periodic replacement as compared to costlier batteries which also have shorter functional life span. The DRB-24V040ABN comes with comprehensive protection features like overvoltage, over current and short circuit protections. The rugged compact aluminium case is shock and vibration resistant according to IEC 60068-2 standard.

Model Information

CliQ II Buffer Module

Model Number	Input Voltage Range	Rated Output Voltage	Rated Output Current
DRB-24V040ABN	22.8-28.8Vdc	24Vdc typ. (Depends on V_{in})	40.0A

Model Numbering

DR	B -	24V	040A	B	N
DIN Rail	Buffer Module	Output Voltage	Output Current	CliQ II Series	N - Metal Case, without Class I, Div 2

CliQ II Buffer Module

24V 40A / DRB-24V040ABN

Specifications

Input Ratings / Characteristics

Nominal Input Voltage		24Vdc
Input Voltage Range		22.8-28.8Vdc
Input Current	Charging Mode	< 0.6A
Max Power Dissipation	Standby Mode	2.5W
Charging Time		< 40s

Output Ratings / Characteristics

Output Voltage Range	Switch = "Fix 22V"	21-22.5Vdc V _{buff} is fixed to 22V. Buffering starts if terminal voltage falls below 22Vdc.
	Switch = "V _{in} -1V" (Factory Setting)	V _{in} -1.5V to V _{in} +0.5V V _{buff} will depend on V _{in} . Buffering starts if terminal voltage is decreased by > 1V typ. The voltage changes slower than 0.5 V/ s will be ignored. If terminal voltage falls below 22Vdc, buffering starts immediately.
Output Current		40A Max
Output Power		960W Max (24V/40A)
PARD (20MHz)		< 350mVpp, buffering mode
Buffering Time		200ms Min @ 24V/40A Load, 8s Min @ 24V/1A Load (Refer to Fig. 1)
Parallel Connection		Yes (to increase buffering current or extend buffering time)
Series Connection		No

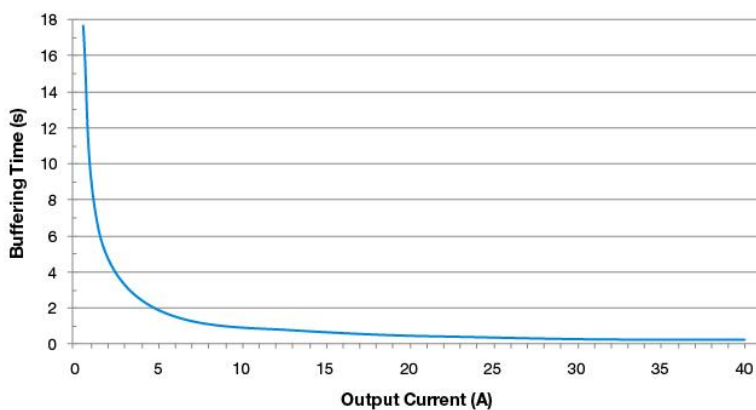

Fig. 1 Buffering Time at 24V Input (Typical Values at "Vin-1V")

CliQ II Buffer Module

24V 40A / DRB-24V040ABN

Mechanical

Case Cover / Chassis	Aluminium	
Dimensions (L x W x D)	121 x 70 x 120.1 mm (4.76 x 2.76 x 4.73 inch)	
Unit Weight	0.90 kg (1.98 lb)	
LED Indicators	Green LED Off	Unit is discharged or $V_{in} < 22Vdc$
	Green LED On	Unit is fully charged (Ready)
	Green LED Flashing Slowly (1Hz)	Unit is charging
	Green LED Flashing Quickly (10Hz)	Unit is discharging (Buffering)
Terminal	Input / Output	4 Pins (Rated 300V/30A)
	Signal	5 Pins (Rated 300V/30A)
Wire	Input / Output	AWG 12-10
	Signal	AWG 24-10
Mounting Rail	Standard TS35 DIN Rail in accordance with EN 60715	
Noise (1 Meter from power supply)	Sound Pressure Level (SPL) < 40dBA	

Environment

Surrounding Air Temperature	Operating	-25°C to +75°C
	Storage	-25°C to +85°C
Power De-rating	Vertical Mounting	> 70°C de-rate power by 5% / °C
	Horizontal Mounting	> 70°C de-rate power by 5% / °C
Operating Humidity	5 to 95% RH (Non-Condensing)	
Operating Altitude	0 to 2,500 Meters (8,200 ft.)	
Shock Test	Non-Operating	IEC 60068-2-27, 30G (300m/S ²) for a duration of 18ms, 1 time per direction, 2 times in total
Vibration	Non-Operating	IEC 60068-2-6, 10Hz to 500Hz @ 30m/S ² (3G peak); 60 min per axis for all X, Y, Z direction
Pollution Degree	2	

Protections

Overvoltage	Yes, 35Vdc Max (the maximum input voltage that will not cause damage to the unit)
Overload / Overcurrent	> 120% of rated load current, Latch-off Mode
Short Circuit	Yes, No damage to the unit, Latch-off Mode
Reverse Polarity Protection	Yes, -35Vdc Max (the maximum input voltage that will not cause damage to the unit)
Degree of Protection	IP20
Protection Against Shock	Class I with PE* connection

*PE: Primary Earth

CliQ II Buffer Module

24V 40A / DRB-24V040ABN

Reliability Data

MTBF (at V_{in} -1V Mode)	> 800,000 hrs. as per Telcordia SR-332 I/P: 24Vdc, Standby Mode, Ta: 25°C
Expected Cap Life Time	10 years (Standby Mode @ 40°C)

Safety Standards / Directives

Electrical Equipment of Machines	EN 60204-1	
Electrical Equipment for Use in Electrical Power Installations	IEC/EN 62477-1 / IEC 62103	
Electrical Safety	SIQ	EN 60950-1, EN 62368-1
	UL/cUL recognized	UL 60950-1 and CSA C22.2 No. 60950-1 (File No. E191395) UL 62368-1 and CSA C22.2 No. 62368-1 (File No. E191395)
	CB scheme	IEC 60950-1, IEC 62368-1
Industrial Control Equipment	UL/cUL listed	UL 508 and CSA C22.2 No. 107.1-01 (File No. E315355)
	CSA	CSA C22.2 No. 107.1-01 (File No. 181564)
CE	In conformance with EMC Directive 2014/30/EU and Low Voltage Directive 2014/35/EU	
Galvanic Isolation	Input & Output / PE	1.5KVac
	Signal / PE	1.5KVac

EMC

Emissions (CE & RE)	Generic Standards: CISPR 32, EN 55032, EN 55011, FCC Title 47: Class B	
Component Power Supply for General Use	EN 61204-3	
Immunity	Generic Standards: EN 55024, EN 61000-6-2	
Electrostatic Discharge	IEC 61000-4-2	Level 4 Criteria A ¹⁾ Air Discharge: 15kV Contact Discharge: 8kV
Radiated Field	IEC 61000-4-3	Level 3 Criteria A ¹⁾ 80MHz-1GHz, 10V/M, 80% modulation (1KHz) 1.4GHz-2GHz, 3V/M, 80% modulation (1KHz) 2GHz-2.7GHz, 1V/M, 80% modulation (1KHz)
Conducted	IEC 61000-4-6	Level 3 Criteria A ¹⁾ 150kHz-80MHz, 10Vrms
Power Frequency Magnetic Fields	IEC 61000-4-8	Criteria A ¹⁾ 30A/Meter

Note: Product intended to be used as Apparatus with AC-DC Power Supply, EMC compliance to be verified in correspondence to the connected units.

1) Criteria A: Normal performance within the specification limits

CliQ II Buffer Module

24V 40A / DRB-24V040ABN

Block Diagram

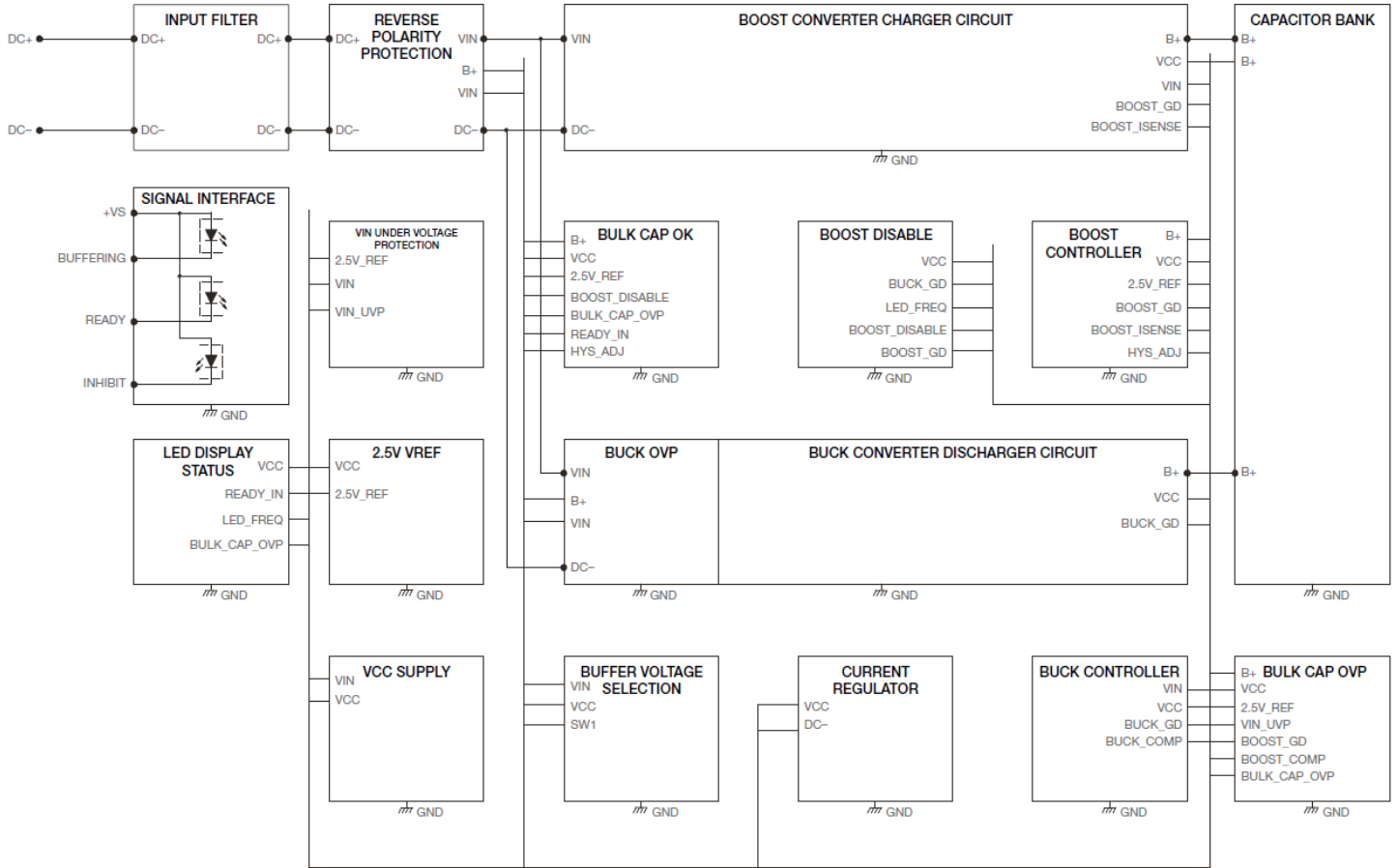

Device Description

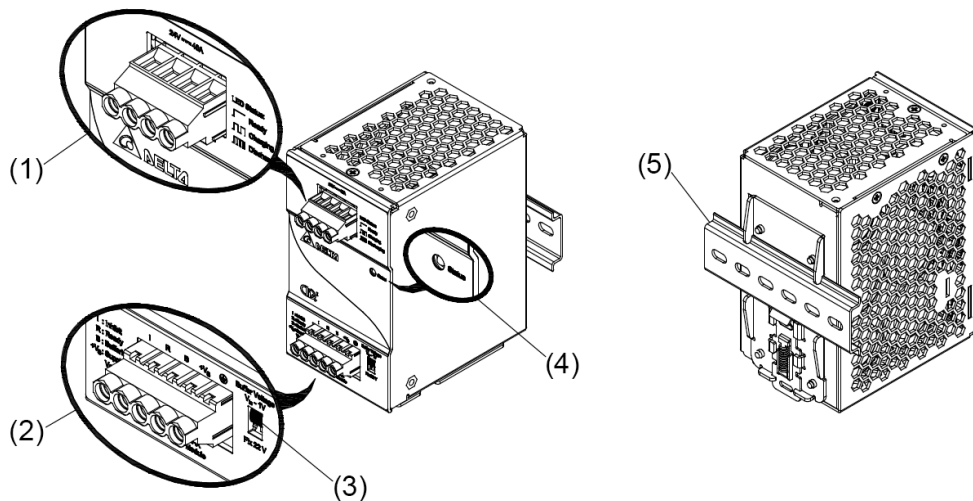

- 1) Input / Output terminal block connector
- 2) Signal terminal block connector
- 3) Select switch (operation mode)
- 4) LED display status
- 5) Universal mounting rail system

CliQ II Buffer Module

24V 40A / DRB-24V040ABN

Dimensions

L x W x D: 121 x 70 x 120.1 mm (4.76 x 2.76 x 4.73 inch)

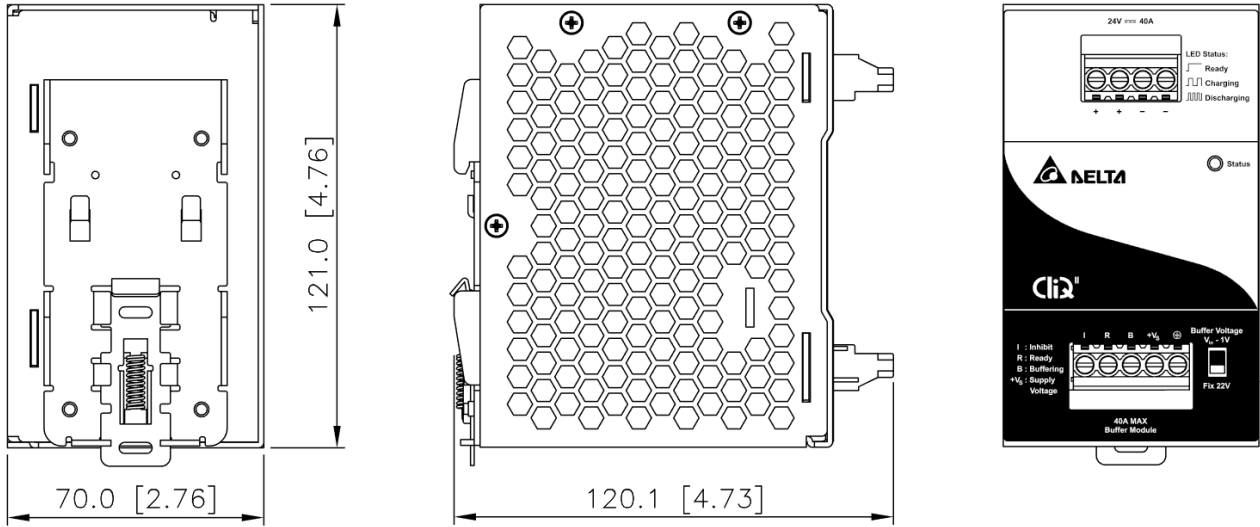

Engineering Data

Output Load De-rating VS Surrounding Air Temperature

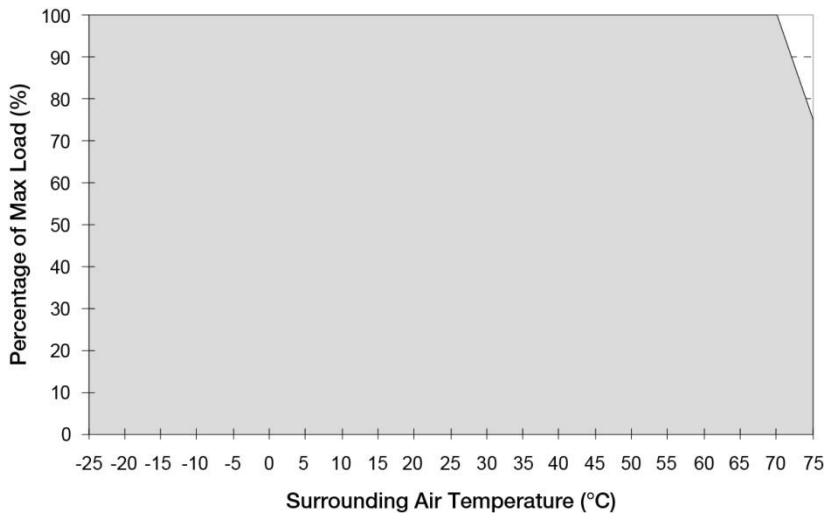

Fig. 2 De-rating for Vertical and Horizontal Mounting Orientation
 > 70°C de-rate power by 5% / °C

Note

1. The unit may degrade, or be damaged, when it is continuously used outside the shaded region, refer to the graph shown in Fig. 2.
2. In order for the device to function in the manner intended, it is also necessary to keep a safety distance as recommended in the safety instructions while the device is in operation.
3. Depending on the surrounding air temperature and output load delivered by the power supply, the device can be very hot!
4. If the device has to be mounted in any other orientation, please contact info@deltapsu.com for more details.

CliQ II Buffer Module

24V 40A / DRB-24V040ABN

Assembly & Installation

The unit can be mounted on 35mm DIN rails in accordance with EN 60715. The device should be installed with Input / Output terminal block at the top.

Each device is delivered ready to install.

Mounting

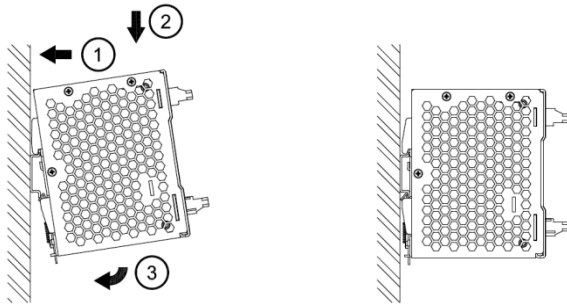

Fig. 3.1 Mounting

Snap on the DIN rail as shown in Fig. 3.1:

1. Tilt the unit upwards and insert it onto the DIN rail.
2. Push downwards until stopped.
3. Press against the bottom front side for locking.
4. Shake the unit slightly to ensure that it is secured.

Dismounting

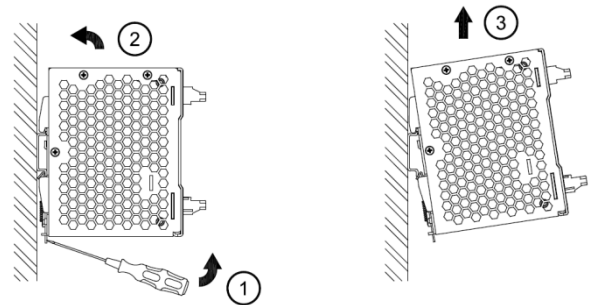

Fig. 3.2 Dismounting

To uninstall, pull or slide down the latch with screw driver as shown in Fig. 3.2. Then slide the unit in the opposite direction, release the latch and pull out the unit from the rail.

In accordance to EN 60950 / UL 60950 and EN 62368 / UL 62368, flexible cables require ferrules.

Use appropriate copper cables designed to sustain operating temperature of:

1. 60°C, 60°C / 75°C for USA
2. At least 90°C for Canada.

CliQ II Buffer Module

24V 40A / DRB-24V040ABN

Safety Instructions

■ Vertical Mounting

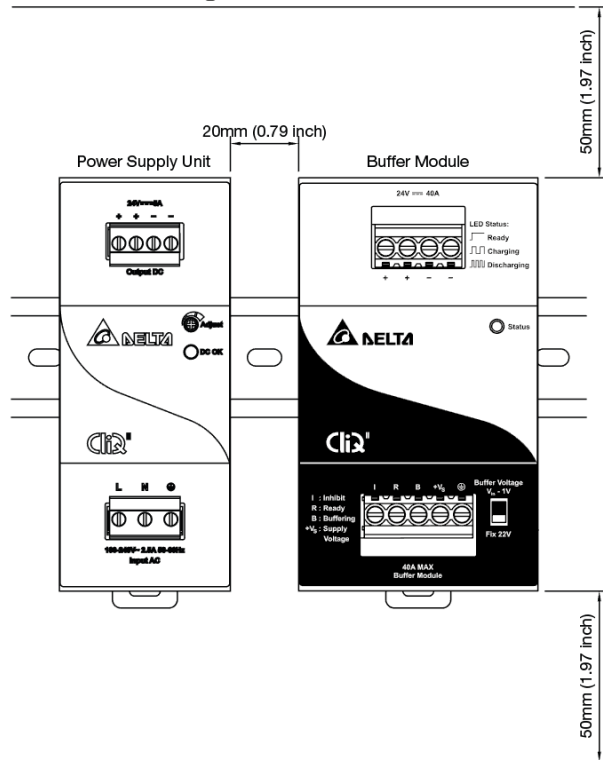

■ Horizontal Mounting

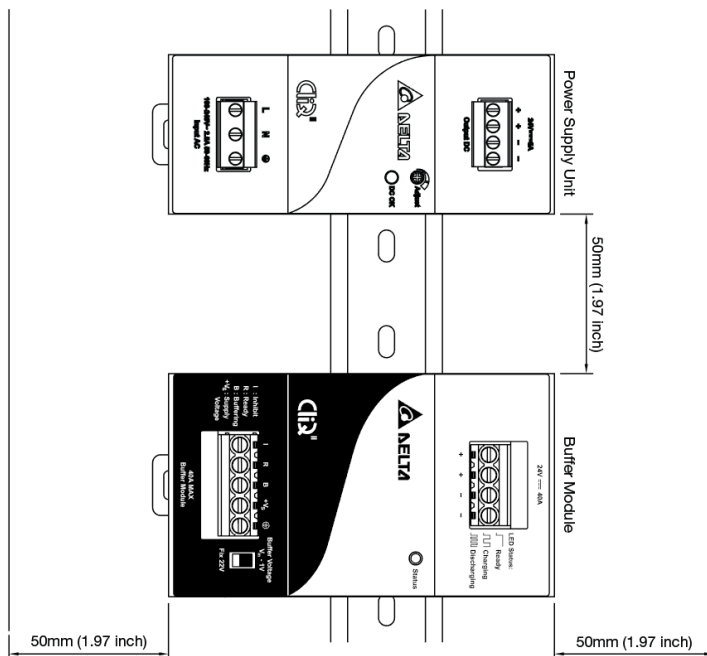

- ALWAYS switch mains of input power OFF before connecting and disconnecting the input voltage to the unit. If mains are not turned OFF, there is risk of explosion / severe damage.
- To guarantee sufficient convection cooling, please refer to the following instructions to ensure sufficient clearance around the device.
Vertical Mounting: 50mm (1.97 inch) above and below the device as well as a lateral distance of 20mm (0.79 inch) to other units.
Horizontal Mounting: 50mm (1.97 inch) above and below the device as well as a lateral distance of 50mm (1.97 inch) to other units.
- Note that the enclosure of the device can become very hot depending on the surrounding air temperature and load of the power supply. Risk of burns!
- The main power must be turned off before connecting or disconnecting wires to the terminals!
- DO NOT insert any objects into the unit.
- Hazardous voltages may be present for up to 5 minutes after the input mains voltage is disconnected. Do not touch the unit during this time.
- The unit is a built-in unit and must be installed in a cabinet or room (condensation free environment and indoor location) that is relatively free of conductive contaminants.

CliQ II Buffer Module

24V 40A / DRB-24V040ABN

Functions

Buffering, Ready and Inhibit Signal Characteristics

Signal Level	Low: < 1V; High: < +V _S -2V
Supply Voltage (+V _S)	Min = 10Vdc, Max = 35Vdc
Maximum Signal Output	35V / 10mA
Buffering Signal (B)	"High" = Buffer module is discharging or in buffering mode
Isolation (Signal Port to Power Port)	1.5KVac
LED Indicator	Green LED Flashing Quickly (10Hz)
Ready Signal (R)	"High" = Buffer module is fully charged or in standby mode
Isolation (Signal Port to Power Port)	1.5KVac
LED Indicator	Green LED On
Inhibit Signal (I)	"Low" = Shuts down buffer module
Isolation (Signal Port to Power Port)	1.5KVac

Operating Diagram

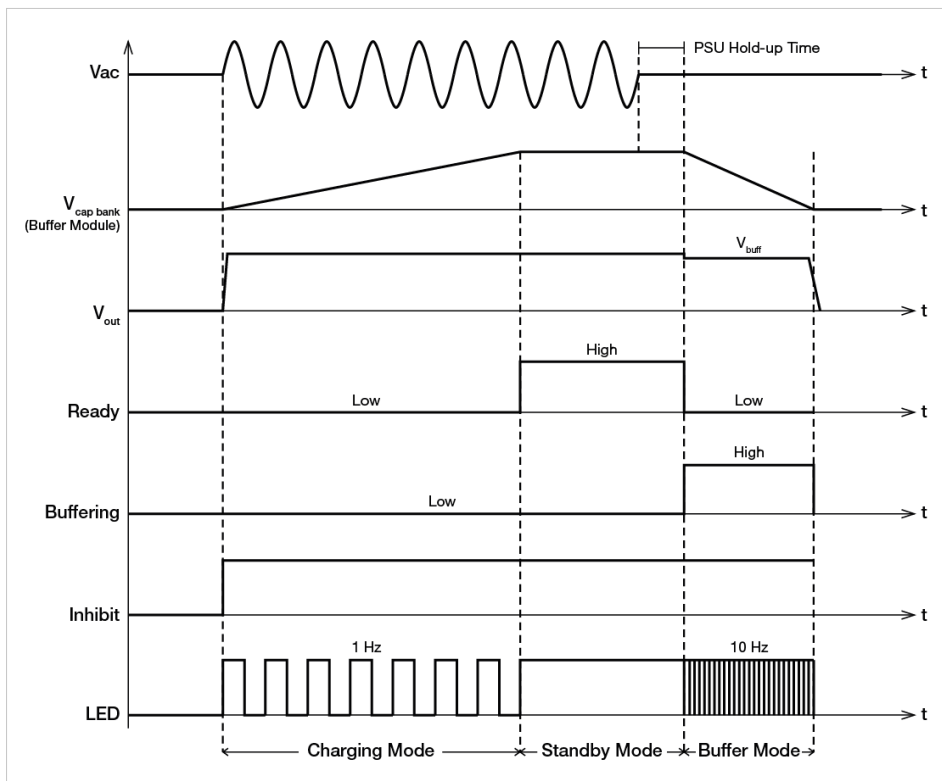

Wiring Schematics

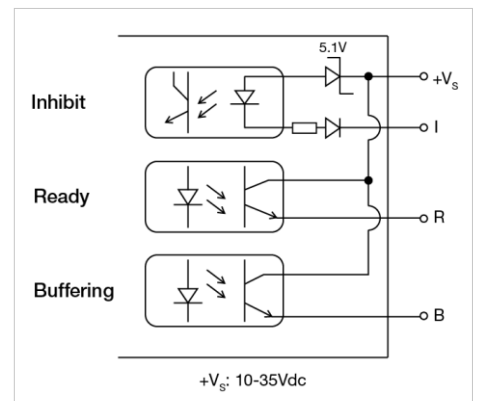

Typical Application Notes can be found on Page 10.

CliQ II Buffer Module

24V 40A / DRB-24V040ABN

Typical Application Notes

Fig. 4.1 General connection / wiring diagram

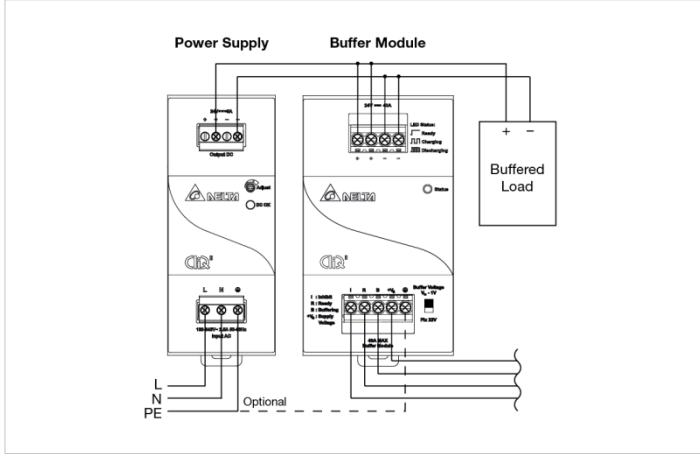

Fig. 4.2 Paralleling of buffer units

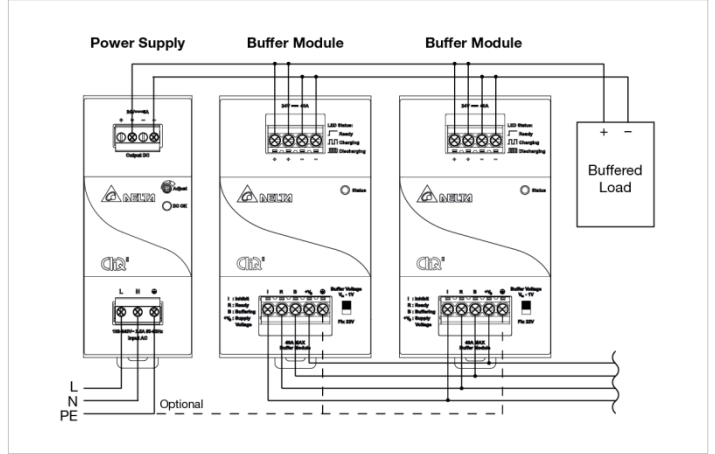

Fig. 4.3 Decoupling of buffered branches

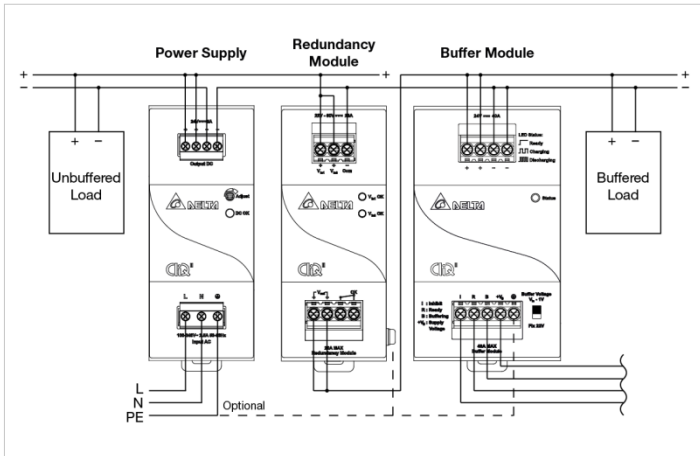

Fig. 4.4 General signals wiring

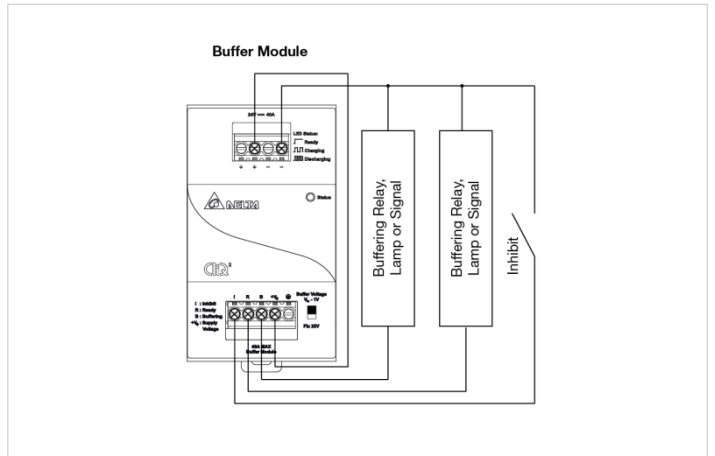

Fig. 4.5 Signals supplied from an external voltage

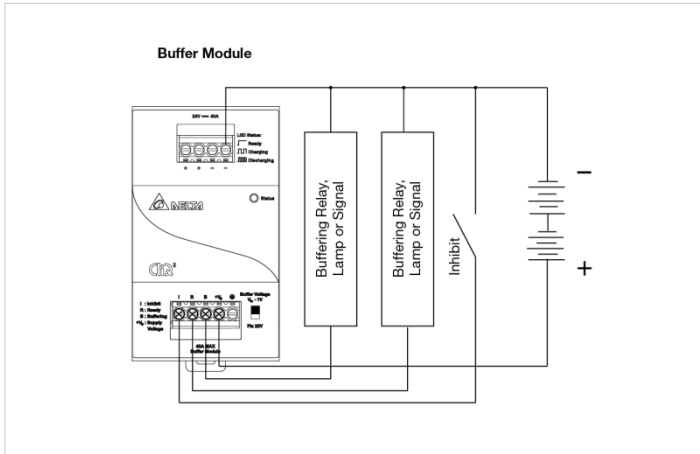
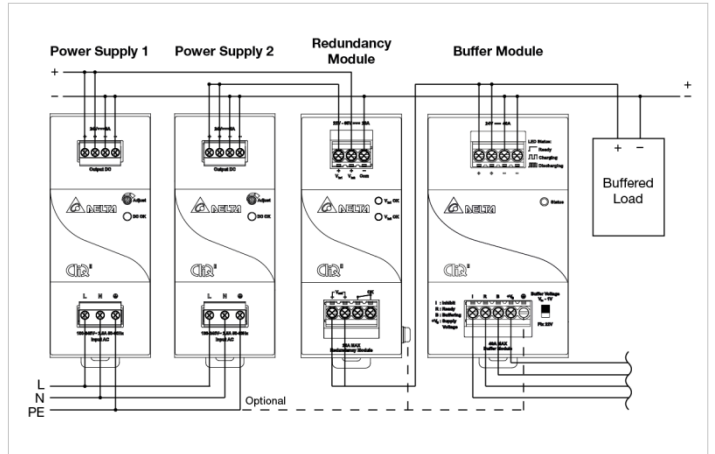

Fig. 4.6 Connection diagram with redundant operation



CliQ II Buffer Module

24V 20A / DRB-24V020AB□

Connectable Power Supplies

The buffer module is recommended to be connected with the following power supplies:

CliQ Series

- DRP-24V48W1AA
- DRP024V060W1AA
- DRP024V060W1AZ
- DRP024V120W1AA
- DRP024V240W1AA
- DRP024V480W1AA

CliQ II Series

- DRP024V060W1B□
- DRP024V060W1N□
- DRP024V120W1B□
- DRP024V240W1B□
- DRP024V480W1B□
- DRP024V060W3B□
- DRP024V120W3B□
- DRP024V240W3B□
- DRP024V480W3B□
- DRP024V960W3BN

Overload & Overcurrent Protections

When the output current exceeds 120% of I_o (Max load) buffer module will shut down and latch. Normal operation of buffer module can be resumed upon removal of fault and power supply input is recycled (ON/OFF) or input to buffer module is recycled.

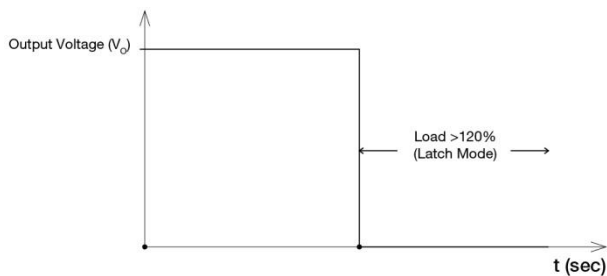

Short Circuit Protection

Buffer module is protected by short circuit during buffering mode, in the event of short circuit the module will shut down and latch. Operation can be resumed upon removal of fault and power supply in put is recycled (ON/OFF) or input to buffer module is recycled.

CliQ II Buffer Module

24V 20A / DRB-24V020AB□

Others

Conformal Coating

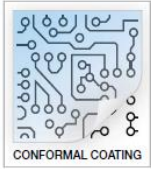

The Protective Coating Technology

Delta Electronics Group has designed the perfect dipping technique which penetrates everywhere including under device, and prevents leakage. The conformal coating dipping can be applied to PCBAs or circuit board. The coating preserves the performance of precision electronic primarily by preventing ionizable contaminants such as salt from reaching circuit nodes, where the material slumps around sharp edges. This can be a problem especially in highly conversing atmosphere.

Attention

Delta provides all information in the datasheets on an "AS IS" basis and does not offer any kind of warranty through the information for using the product. In the event of any discrepancy between the information in the catalog and datasheets, the datasheets shall prevail (please refer to www.DeltaPSU.com for the latest datasheets information). Delta shall have no liability of indemnification for any claim or action arising from any error for the provided information in the datasheets. Customer shall take its responsibility for evaluation of using the product before placing an order with Delta.

Delta reserves the right to make changes to the information described in the datasheets without notice.