

# KD331-Q170

Desktop

Q170

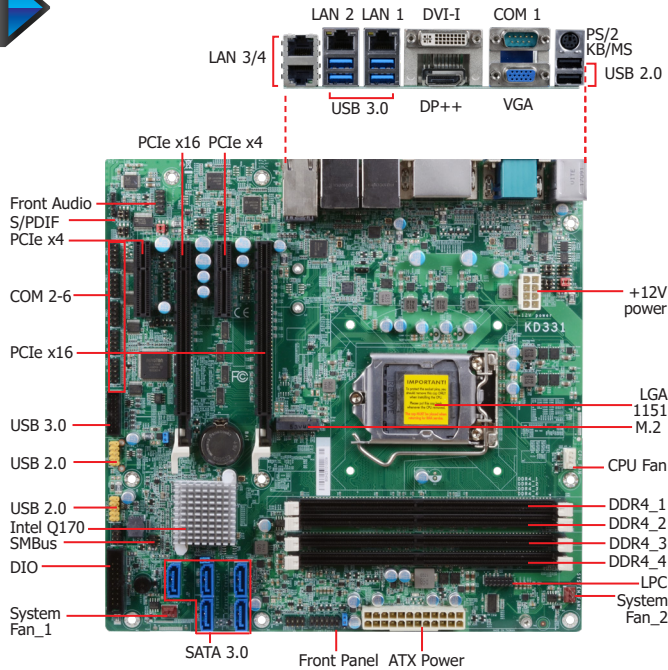

## Features

- 4 DDR4 DIMM up to 64GB
- Three independent displays: VGA + DVI-I + DP++
- DP++ resolution up to 4096x2106 @ 60Hz
- Multiple expansion: 2 PCIe x16 (1 x16 or 2 x8 signal), 2 PCIe x4, 1 M.2, 1 LPC
- Rich I/O: 4 Intel GbE, 6 COM, 6 USB 3.0, 6 USB 2.0
- LPC EXT-RS232/485 module extends additional 4 COM ports

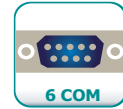

## Ordering Information

Model Name	P/N	Memory	GbE	RS-232/422/485	RS-232	USB 3.0	USB 2.0	Power	Thermal	Temp.
<b>KD331-Q170IRM</b>	770-KD3312-000G	4 DIMM	4	2	4	6	6	24-pin ATX	Active	0 to 60°C

## Mechanical Drawing

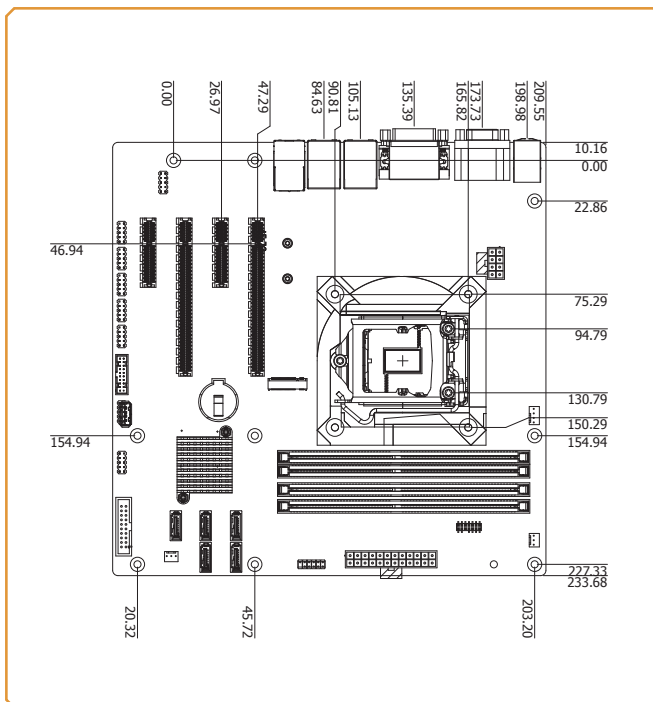

## Block Diagram

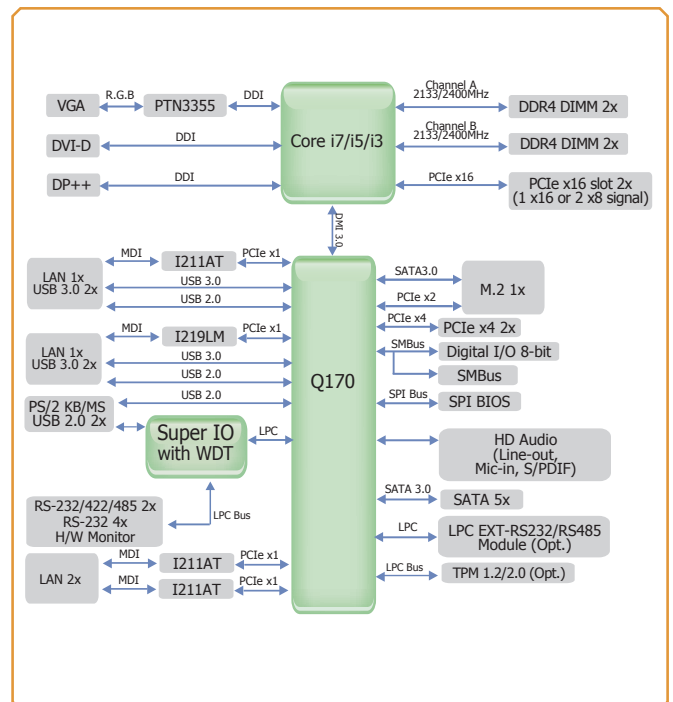

## Specifications

<b>SYSTEM</b>	<b>Processor</b>	6th/7th Generation Intel® Core™ /Pentium®/Celeron® LGA 1151 Socket Processors with TDP up to 95W	
	<b>Chipset</b>	Intel® Q170 Chipset	
	<b>Memory</b>	Four 288-pin DIMM up to 64GB	Dual Channel DDR4 2133/2400 MHz
	<b>BIOS</b>	Insyde SPI 128Mbit	
<b>GRAPHICS</b>	<b>Controller</b>	Intel® HD Gen 9 Graphics	
	<b>Feature</b>	OpenGL 5.0, DirectX 12, OpenCL 2.1 HW Decode: AVC/H.264, MPEG2, VC1/WMV9, JPEG/MJPEG, HEVC/H265, VP8, VP9 HW Encode: MPEG2, AVC/H264, JPEG, HEVC/H265, VP8, VP9	
	<b>Display</b>	1 x VGA 1 x DVI-I (DVI-I-D signal) 1 x DP++	VGA: resolution up to 1920x1200 @ 60Hz DVI-I: resolution up to 1920x1200 @ 60Hz DP++: resolution up to 4096x2106 @ 60Hz
	<b>Triple Displays</b>	VGA + DVI-I (DVI-D signal) + DP++	
<b>EXPANSION</b>	<b>Interface</b>	2 x PCIe x16 (1 x16 or 2 x8 signal) (Gen 3) 2 x PCIe x4 (Gen 3) 1 x M.2 2260/2280 M key (SATA3.0/PCIe Gen3 x2 NVMe)	
<b>AUDIO</b>	<b>Audio Codec</b>	Realtek ALC888S-VD2-GR	
<b>ETHERNET</b>	<b>Controller</b>	3 x Intel® I211AT PCIe (10/100/1000Mbps) 1 x Intel® I219LM PCIe (10/100/1000Mbps) (only Core™ i7/i5 supports iAMT)	
<b>REAR I/O</b>	<b>Ethernet</b>	4 x GbE (RJ-45)	
	<b>USB</b>	4 x USB 3.0 2 x USB 2.0	
	<b>Serial</b>	1 x RS-232/422/485 (RS-232 w/ power) (DB-9)	
	<b>PS/2</b>	1 x PS/2 (mini-DIN-6)	
	<b>Display</b>	1 x VGA 1 x DVI-I (DVI-D signal) 1 x DP++	
	<b>INTERNAL I/O</b>	<b>Serial</b>	1 x RS-232/422/485 (RS-232 w/ power) (2.54mm pitch) 4 x RS-232 (2.54mm pitch)
<b>USB</b>		2 x USB 3.0 (2.00mm pitch) 4 x USB 2.0 (2.54mm pitch) or 2 x USB2.0 (2.54mm pitch) +1 x Vertical USB 2.0 (opt., MOQ required)	
<b>Audio</b>		1 x Front Audio Header 1 x S/PDIF	
<b>SATA</b>		5 x SATA 3.0 (up to 6Gb/s)	RAID 0/1/5/10
<b>DIO</b>		1 x 8-bit DIO	
<b>LPC</b>		1 x LPC (supports LPC EXT-RS232/RS485 module)	
<b>SMBus</b>		1 x SMBus	
<b>WATCHDOG TIMER</b>		<b>Output &amp; Interval</b>	System Reset, Programmable via Software from 1 to 255 Seconds
<b>SECURITY</b>	<b>TPM</b>	Infineon TPM2.0/1.2 (opt., MOQ required)	
<b>POWER</b>	<b>Type</b>	ATX	
	<b>Connector</b>	8-pin ATX 12V power	24-pin ATX power
	<b>Consumption</b>	Typical: i7-7700: 3.3V @ 0.4817A (1.58961W); 5V @ 0.5781A (2.8905W); 12V @ 0.3707A (4.4484W) Max.: i7-7700: 3.3V @ 0.476A (1.5708W); 5V @ 0.6863A (3.4315W); 12V @ 9.2347A (110.816W)	
	<b>RTC Battery</b>	CR2032 Coin Cell	
<b>OS SUPPORT</b>		Windows 7 32/64-bit Windows 8.1 64-bit Windows 10 64-bit Linux Note: 7th Gen CPU SKU ONLY support Windows 10 64-bit & Linux.	
<b>ENVIRONMENT</b>	<b>Temperature</b>	Operating: 0 to 60°C	Storage: -30 to 60°C with RTC Battery -40 to 85°C without RTC Battery
	<b>Humidity</b>	Operating: 5 to 90% RH	Storage: 5 to 90% RH
	<b>MTBF</b>	503,212hrs @ 25°C; 281,329hrs @ 45°C ; 175,239hrs @ 60°C Calculation Model: Telcordia Issue 4 Environment: GB, GC - Ground Benign, Controlled	
<b>MECHANICAL</b>	<b>Dimensions</b>	microATX form factor	244mm (9.6") x 244mm (9.6")
	<b>Height</b>	PCB: TBD	Top Side: TBD, Bottom Side: TBD
<b>CERTIFICATIONS</b>		CE, FCC, RoHS, UL	

## Packing List

• 1 KD331-Q170 motherboard	
• 1 COM port cables (Length: 300mm, 2 x COM ports)	A81-015026-023G
• 1 Serial ATA data cable (Length: 500mm)	332-553001-005G
• 1 I/O shield	A49-KD3310-000G
• 1 M.2 standoff	A33-725019-090G
• 1 M.2 screw	A32-112016-041G

## Optional Items

• USB 2.0 port cable (Length: 350mm)	A81-001066-016G
• USB 3.0 port cable (Length: 320mm)	A81-001052-023G
• D-SUB cable (w/Bracket, Length: 300mm, 2 x DB9)	A81-015026-023G
• Serial ATA data cable (w/Lock, Length: 500mm)	332-553001-005G
• Thermal solution (For 35W, Height: 37.3mm)	A71-103004-000G
• Thermal solution (For 65W, Height: 72.8mm)	552-200049-000G
• Thermal solution (For 95W, Height: 69.3mm)	761-103001-000G
• LPC EXT-RS232 module (4 x RS232 ports)	770-EXTRS1-000G
• DP to HDMI Dongle	612-D2H13M-000G