

CS330-Q370

Desktop

Q370

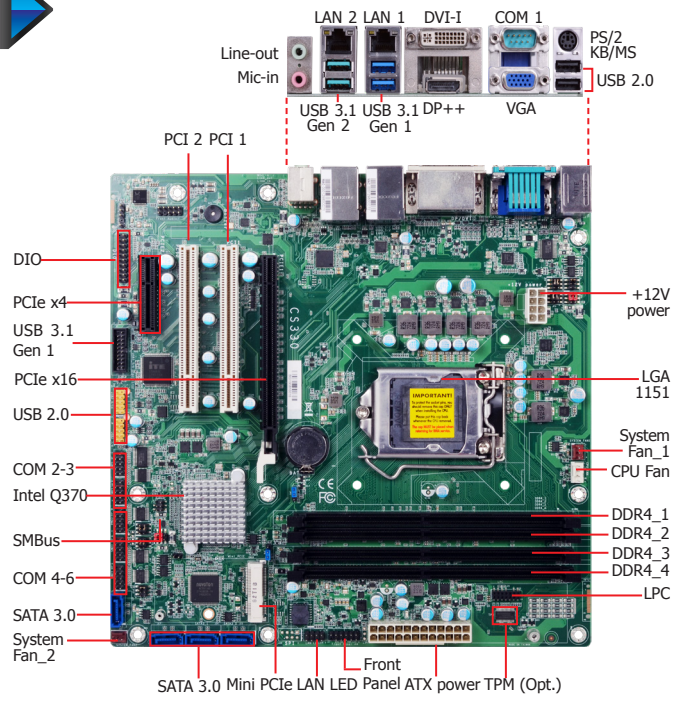

Features

- 4 DDR4 DIMM up to 128GB
- Three display ports: VGA, DVI-D, DP++ Supports three independent displays
- DP++ resolution up to 4096x2160 @ 60Hz DVI-D resolution up to 1920x1200 @ 60Hz
- Multiple expansion: 1 PCIe x16, 1 PCIe x4, 2 PCI, 1 Mini PCIe
- Rich I/O: 2 Intel GbE, 6 COM, 2 USB 3.1 Gen 2, 4 USB 3.1 Gen 1, 6 USB 2.0



Ordering Information

Model Name	P/N	Memory	GbE	RS-232/422/485	RS-232	USB 3.1 Gen 1	USB 3.1 Gen 2	U S B 2.0	Power	Thermal	Temp.
CS330-Q370CRM	770-CS3301-100G	4 DIMM	2	2	4	4	2	6	24-pin ATX/8-pin ATX 12V	Active	0 to 60°C

Mechanical Drawing

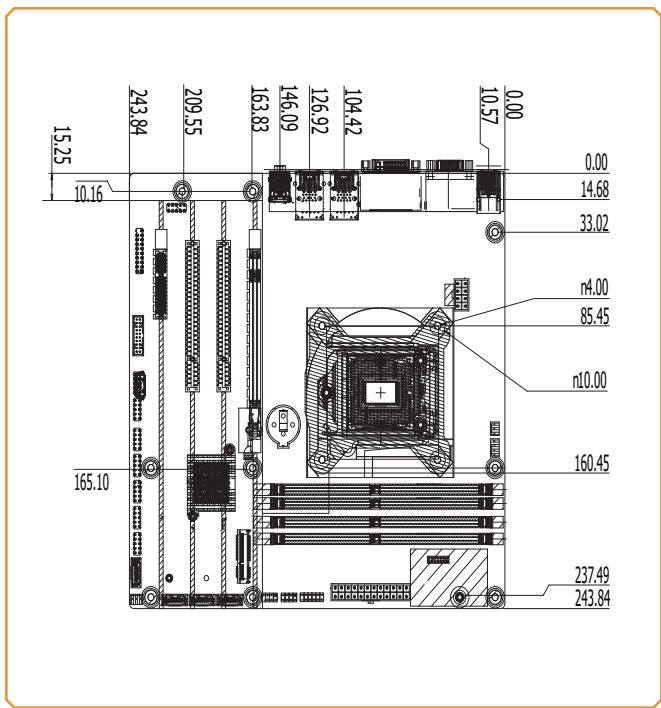

Block Diagram

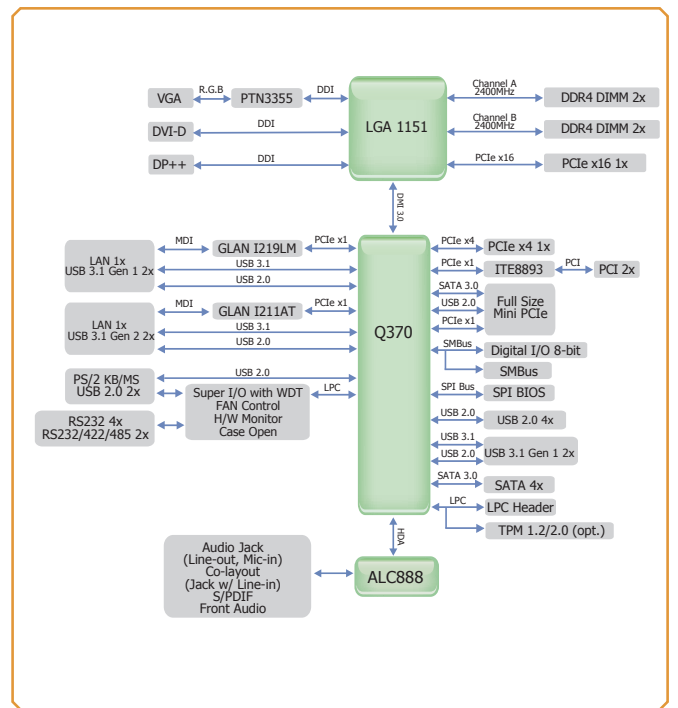

► Specifications

SYSTEM	Processor	8th Generation Intel® Core™ /Pentium®/Celeron® LGA 1151 Socket Processors: Intel® Core™ i7-8700K (6 Cores, 12M Cache, up to 4.7 GHz); 95W Intel® Core™ i7-8700 (6 Cores, 12M Cache, up to 4.6 GHz); 65W Intel® Core™ i7-8700T (6 Cores, 12M Cache, up to 4.0 GHz); 35W Intel® Core™ i5-8500 (6 Cores, 9M Cache, up to 4.1 GHz); 65W Intel® Core™ i5-8500T (6 Cores, 9M Cache, up to 3.5 GHz); 35W Intel® Core™ i3-8100 (4 Cores, 6M Cache, 3.6 GHz); 65W Intel® Core™ i3-8100T (4 Cores, 6M Cache, to 3.1 GHz); 35W Intel® Pentium® G5400 (2 Cores, 4M Cache, 3.7 GHz); 58W Intel® Pentium® G5400T (2 Cores, 4M Cache, 3.1 GHz); 35W Intel® Celeron® G4900 (2 Cores, 2M Cache, 3.1 GHz); 54W Intel® Celeron® G4900T (2 Cores, 2M Cache, 2.9 GHz); 35W 9th Generation Intel® Core™ LGA 1151 Socket Processors: Intel® Core™ i7-9700TE (8 Cores, 12M Cache, up to 3.8 GHz); 35W Intel® Core™ i5-9500E (6 Cores, 9M Cache, up to 4.2 GHz); 65W Intel® Core™ i5-9500TE (6 Cores, 9M Cache, up to 3.6 GHz); 35W Intel® Core™ i3-9100E (4 Cores, 6M Cache, 3.7 GHz); 65W Intel® Core™ i3-9100TE (4 Cores, 6M Cache, to 3.2 GHz); 35W	
	Chipset	Intel® Q370 Chipset	
	Memory	Four 288-pin DIMM up to 128GB	Dual Channel DDR4 2400/2666 MHz
	BIOS	AMI SPI 128Mbit	
GRAPHICS	Controller	Intel® HD Gen 9 Graphics	
	Feature	OpenGL 5.0, DirectX 12, OpenCL 2.1 HW Decode: AVC/H.264, MPEG2, VC1/WMV9, JPEG/MJPEG, HEVC/H265, VP8, VP9 HW Encode: MPEG2, AVC/H264, JPEG, HEVC/H265, VP8, VP9	
	Display	1 x VGA 1 x DVI-I (DVI-D signal) 1 x DP++	VGA: resolution up to 1920x1200 @ 60Hz DVI-D: resolution up to 1920x1200 @ 60Hz DP++: resolution up to 4096x2160 @ 60Hz
	Triple Displays	VGA + DVI-D + DP++	
EXPANSION	Interface	1 x PCIe x16 (Gen 3) 1 x PCIe x4 (Gen 3)	1 x Full-size Mini PCIe (USB/PCIe/mSATA, PCIe by default) 2 x PCI
AUDIO	Audio Codec	Realtek ALC888	
ETHERNET	Controller	1 x Intel® I211AT (10/100/1000Mbps) 1 x Intel® I219LM with iAMT12.0 (10/100/1000Mbps) (only Core i7/i5 supports iAMT)	
REAR I/O	Ethernet	2 x GbE (RJ-45)	
	USB	2 USB 3.1 Gen 2 2 USB 2.0	2 USB 3.1 Gen 1
	Serial	1 x RS-232/422/485 (RS-232 w/ power) (DB-9)	
	PS/2	1 x PS/2 (mini-DIN-6)	
	Display	1 x VGA 1 x DP++	1 x DVI-I (DVI-D signal)
	Audio	1 x Line-out 1 x Line-in (opt.)	1 x Mic-in
	INTERNAL I/O	Serial	1 x RS-232/422/485 (RS-232 w/ power) (2.54mm pitch) 4 x RS-232
USB		2 x USB 3.1 Gen 1 (2.00mm pitch)	4 x USB 2.0 (2.54mm pitch)
Audio		1 x S/PDIF	1 x Front Audio Header
SATA		4 x SATA 3.0 (up to 6Gb/s)	RAID 0/1/5/10
DIO		1 x 8-bit DIO	
LPC		1 x LPC	
SMBus		1 x SMBus	
WATCHDOG TIMER		Output & Interval	System Reset, Programmable via Software from 1 to 255 sec/min
SECURITY	TPM	Infineon TPM2.0/1.2 (optional)	
POWER	Type	ATX	
	Connector	8-pin ATX 12V power	24-pin ATX power
	Consumption	Typical: i7-8700K: 3.3V @ 0.29A (0.957Watt); 5V @ 0.53A (2.65Watt); 12V @ 1.08A (12.96Watt) Max.: i7-8700K: 3.3V @ 0.49A (1.617Watt); 5V @ 0.53A (2.65Watt); 12V @ 13.39A (160.68Watt)	
	RTC Battery	CR2032 Coin Cell	
OS SUPPORT		Windows 10 IoT Enterprise	Linux
ENVIRONMENT	Temperature	Operating: 0 to 60°C	Storage: -40 to 85°C
	Humidity	Operating: 5 to 90% RH	Storage: 5 to 90% RH
	MTBF	535,676 hrs @ 25°C; 352,865 hrs @ 40°C ; 303,603 hrs @ 45°C ; 189,856 hrs @ 60°C Calculation Model: Telcordia Issue 4 Environment: GB, GC - Ground Benign, Controlled	
	MECHANICAL	Dimensions	microATX form factor
Height		PCB: 1.6mm	Top Side: 31.47mm, Bottom Side: 4.4mm
CERTIFICATION		UL, CE, FCC, RoHS, KCC	

► Packing List

• 1 CS330-Q370 motherboard	
• 1 COM port cable (W/Bracket, Length: 300mm, 2 x COM ports)	A81-015026-023G
• 1 Serial ATA data cable (W/LOCK, Length: 500mm)	332-553001-005G
• 1 Screw of Mini PCIE card	531-510180-000G

► Optional Items

• USB 2.0 port cable (Length: 350mm)	A81-001066-016G
• USB 3.0 port cable (Length: 350mm)	A81-001052-023G
• COM port cable (Length: 300mm, 2 x COM ports)	A81-015026-023G
• Serial ATA data cable (Length: 500mm)	332-553001-005G
• Thermal solution (For 35W, Height: 37.3mm)	A71-101107-000G
• Thermal solution (For 65W, Height: 72.8mm)	552-200049-000G
• Thermal solution (For 95W, Height: 69.3mm)	761-103001-000G
• LPC EXT-RS232 module (4 x RS232 ports)	770-EXTRS1-000G
• LPC EXT-RS485 module (4 x RS485 ports)	770-EXTRS1-100G
• DP to HDMI Dongle	612-D2H13M-000G