

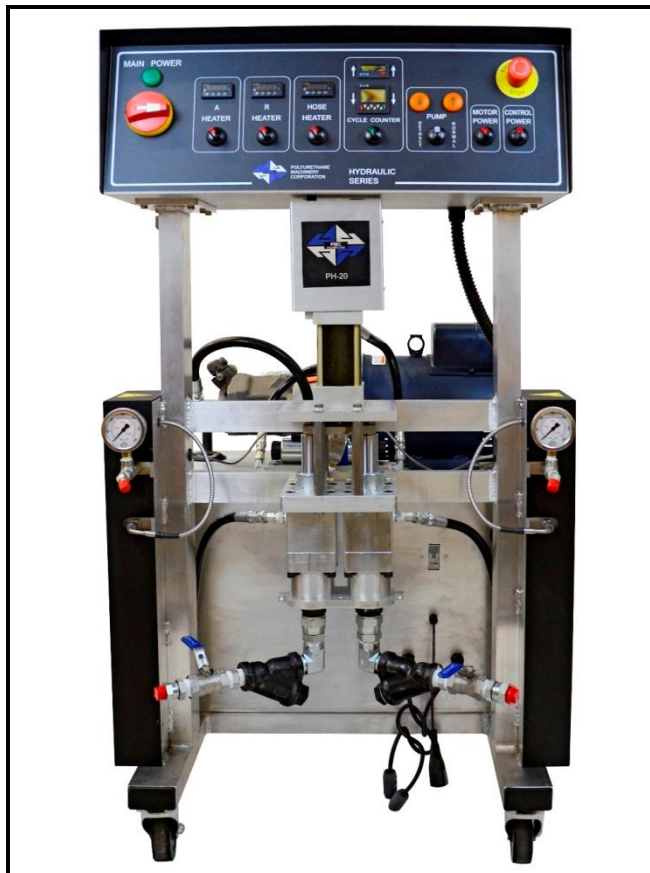

# POLYURETHANE MACHINERY CORPORATION



## PH-20/PHX-20 Proportioner

Hydraulic, Heated Plural Component Proportioner  
For Spraying Polyurethane Foam and Coatings  
For Professional Use Only  
Not approved for use in European explosive  
atmosphere locations

Manual  
Ref. # MN-04007

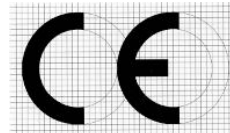

**November 20, 2013**

### **Polyurethane Machinery Corp.**

Corporate: 1 Komo Drive, Lakewood, NJ 08701

Manufacturing: 2 Komo Drive, Lakewood, NJ 08701

Phone: 732-415-4400 Fax: 732-364-4025

<http://www.polymac-usa.com>



Before installing the PH Series Proportioner and start-up, carefully read all the technical and safety documentation included in this manual. Pay special attention to the information in order to know and understand the operation and the conditions of use of the PH Series Proportioner. All of the information is aimed at improving user safety and avoiding possible breakdowns from the incorrect use of the PH Series Proportioner



# PH-20/PHX-20 Manual

|  |    |
|--|----|
| <b>Warranty</b> .....                            | 3  |
| <b>Safety and Handling</b> .....                 | 5  |
| <b>Characteristics</b>                           |    |
| <u>Principal Heating System</u> .....            | 7  |
| <u>Hose Heating System</u> .....                 | 7  |
| <u>Double Acting Piston Metering Pumps</u> ..... | 7  |
| <b>Technical Specifications</b>                  |    |
| <u>Electrical</u> .....                          | 8  |
| <u>Mechanical</u> .....                          | 8  |
| <b>Description</b> .....                         | 9  |
| <b>Installation</b> .....                        | 14 |
| <b>Proportioner Purging</b> .....                | 20 |
| <b>Digital Temperature Controller</b> .....      | 22 |
| <b>Start-Up</b> .....                            | 23 |
| <b>Shutdown Procedures</b> .....                 | 25 |
| <b>Troubleshooting</b> .....                     | 26 |
| <u>Heaters</u> .....                             | 27 |
| <u>Hydraulic Drive System</u> .....              | 30 |
| <u>Metering Pump Line</u> .....                  | 33 |
| <u>Hose Heating</u> .....                        | 37 |
| <b>Maintenance</b> .....                         | 41 |
| <u>Inlet Material Screens</u> .....              | 42 |
| <u>Hydraulic Drive System</u> .....              | 43 |
| <u>Metering Pump Line</u> .....                  | 44 |
| <u>Material Heater</u> .....                     | 45 |
| <b>Hydraulic Oil Specification</b> .....         | 47 |
| <b>Parts Identification</b> .....                | 46 |
| <u>Replacement Kits</u> .....                    | 48 |
| <u>Machine Spare Parts</u> .....                 | 49 |
| <u>Hoses</u> .....                               | 52 |
| <u>PHX20, 3000 PSI Pump Line-61</u> .....        | 54 |
| <u>PH-20, 2000 PSI Pump Line-123</u> .....       | 56 |
| <u>Electrical Parts</u> .....                    | 58 |
| <u>Electrical Schematics</u> .....               | 62 |



# PH-20/PHX-20 Manual

## WARRANTY

Polyurethane Machinery Corporation (hereinafter “PMC”) provides this **LIMITED WARRANTY** (hereinafter “Warranty”) to the original purchaser (hereinafter “Customer”) covering this equipment and the original PMC manufactured accessories delivered with the equipment (hereinafter “Product”) against defects in material or workmanship of the Product (hereinafter “Defect” or “Defective”) for a period of one (1) year from the date of first purchase as shown on the original PMC invoice (hereinafter “Warranty Period”).

If during the Warranty Period under normal use, the Product is suspected by Customer to be Defective in material or workmanship, it is Customer’s responsibility to contact PMC and return the Product to PMC as directed by PMC, freight prepaid. If PMC determines that the Product is Defective and that such Defect is covered by this Warranty, PMC will credit Customer for the reasonable freight charges incurred by Customer in returning the Defective Product to PMC, and PMC (or its authorized agent) will, at PMC’s option, repair or replace the Product, subject to the following:

Original Invoice: The original invoice must be kept as proof of the date of first sale and the Product serial number. The Warranty does not cover any Product if the Original Invoice appears to have been modified or altered, or when the serial number on the Product appears to have been altered or defaced.

Product Maintenance: It is the Customer’s responsibility to maintain the Product properly. See your maintenance schedule and owner’s manual for details. The Warranty does not cover an improperly maintained Product.

Non-PMC Components and Accessories: Non-PMC manufactured components and accessories that are used in the operation of the Product are not covered by this Warranty. Such components and accessories shall be subject to the warranty offered to the Customer, if any, by the original manufacturer of such component or accessory.

Other Warranty Exclusions: The Warranty does not cover any Product that PMC determines has been damaged or fails to operate properly due to misuse, negligence, abuse, carelessness, neglect, or accident. By way of example only, this includes:

- Normal wear and tear.

- Improper or unauthorized installation, repair, alteration, adjustment or modification of the Product.

- Use of heating devices, pumping equipment, dispensers, or other parts or accessories with the Product that have not been approved or manufactured by PMC.

- Failure to follow the operating instructions and recommendations provided by PMC.

- Cosmetic damage.

- Fire, flood, “acts of God,” or other contingencies beyond the control of PMC.



# PH-20/PHX-20 Manual

## WARRANTY (cont'd)

**THE WARRANTY DESCRIBED HEREIN IS THE EXCLUSIVE REMEDY FOR THE CUSTOMER AND IS IN LIEU OF ALL OTHER WARRANTIES, EXPRESS, IMPLIED, STATUTORY OR OTHERWISE, AND THE IMPLIED WARRANTIES OF MERCHANTABILITY AND FITNESS FOR A PARTICULAR PURPOSE AND ALL OTHER WARRANTIES ARE HEREBY DISCLAIMED. TO THE FULLEST EXTENT PERMITTED BY LAW, PMC SHALL NOT BE RESPONSIBLE, WHETHER BASED IN CONTRACT, TORT (INCLUDING, WITHOUT LIMITATION, NEGLIGENCE), WARRANTY OR ANY OTHER LEGAL OR EQUITABLE GROUNDS, FOR ANY CONSEQUENTIAL, INDIRECT, INCIDENTAL, LOST PROFITS, SPECIAL, PUNITIVE OR EXEMPLARY DAMAGES, WHETHER TO PERSON OR PROPERTY, ARISING FROM OR RELATING TO THE PRODUCT, EVEN IF PMC HAS BEEN ADVISED OF THE POSSIBILITY OF SUCH LOSSES OR DAMAGES.**

Non-Warranty Service by PMC: If PMC determines that the suspected Defect of the Product is not covered by this Warranty, disposition of the Product will be made pursuant to the terms and conditions of PMC's written estimate on a time and materials basis.

Continuing Warranty for Products Repaired or Replaced under Warranty: Following the repair or replacement of a Product covered by this Warranty, such Product will continue to be subject to the original Warranty for the remainder of original Warranty Period or for three (3) months from the repair or replacement date, whichever is longer.

No Rights Implied: Nothing in the sale, lease or rental of any Product by PMC shall be construed to grant any right, interest or license in or under any patent, trademark, copyright, trade secret or other proprietary right or material owned by anyone; nor does PMC encourage the infringement of same.

Exclusive Warranty: This writing is the final, complete, and exclusive expression of the Warranty covering the Product. Any statements made by PMC, its employees or agents that differ from the terms of this Warranty shall have no effect. It is expressly understood that Customer's acceptance of this Warranty, by performance or otherwise, is upon and subject solely to the terms and conditions hereof, and any additional or different terms and conditions proposed or expressed by Customer or anyone, whether in writing or otherwise, are null and void unless specifically agreed to in writing by an Officer of PMC.



# PH-20/PHX-20 Manual

## **SAFETY AND HANDLING**

This chapter contains important information on the safety, handling and use of your *Classic* PH Series Proportioner.



***Before installing the PH Series Proportioner and start-up, carefully read all the technical and safety documentation included in this manual. Pay special attention to the information to know and understand the operation and the conditions of use of the PH Series Proportioner. All of the information is aimed at enhancing User Safety and avoiding possible breakdowns derived from the incorrect use of the PH Series Proportioner.***

***WARNING!*** presents information to alert of a situation that might cause serious injuries if the instructions are not followed.

***CAUTION!*** presents information that indicates how to avoid damage to the Proportioner or how to avoid a situation that could cause minor injuries.

***NOTE!*** is relevant information of a procedure being carried out.

Careful study of this manual will enable the operator to know the characteristics of the PH Series Proportioner and the operating procedures. By following the instructions and recommendations contained herein, you will reduce the potential risk of accidents in the installation, use or maintenance of the PH Series Proportioner; you will provide a better opportunity for incident-free operation for a longer time, greater output and the possibility of detecting and resolving problems fast and simply.

Keep this Operations Manual for future consultation of useful information at all times. If you lose this manual, ask for a new copy from your PMC Service Center, directly contact PMC or on line at our web site ([www.polymac-usa.com](http://www.polymac-usa.com)).



# PH-20/PHX-20 Manual

## **SAFETY AND HANDLING (cont'd)**

The PH Series Proportioner has been designed and built for the application of polyurea chemical systems, polyurethane foam chemical systems and some two-component epoxy systems.

**WARNING!** The design and configuration of the PH Series Proportioner does not allow its use in potentially explosive atmospheres or the pressure and temperature limits described in the technical specifications of this manual to be exceeded.

Always use liquids and solvents that are compatible with the unit. If in doubt, consult PMC Technical Service.

When working with the PH Series Proportioner, it is recommended that the operator wear suitable clothing and elements of personal protection, including, without limitation, gloves, protective goggles, safety footwear and face masks. Use breathing equipment when working with the PH Series Proportioner in enclosed spaces or in areas with insufficient ventilation. The introduction and follow-up of safety measures must not be limited to those described in this manual. Before starting up the PH Series Proportioner, a comprehensive analysis must be made of the risks derived from the products to be dispensed, the type of application and the working environment.



***To prevent possible injury caused by incorrect handling of the raw materials and solvents used in the process, carefully read the Material Safety Data Sheet (MSDS) provided by your supplier.***

***Deal with the waste caused according to current regulations.***

***To avoid damage caused by the impact of pressurized fluids, do not open any connection or perform maintenance work on components subject to pressure until the pressure has been completely eliminated.***

***Use suitable protection when operating, maintaining or being present in the area where the equipment is functioning. This includes, but is not limited to, the use of protective goggles, gloves, shoes and safety clothing and breathing equipment.***

***The equipment includes components that reach high temperatures and can cause burns. Hot parts of the equipment must not be handled or touched until they have cooled completely.***

***To prevent serious injury through crushing or amputation, do not work with the equipment without the safety guards installed on the moving parts. Make sure that all the safety guards are correctly reinstalled at the end of the repair or maintenance work of the equipment***



# PH-20/PHX-20 Manual

## **CHARACTERISTICS**

The PH-20/PAX-20 Proportioner has been designed and built for the application of polyurea chemical systems, polyurethane foam chemical systems and some specific two-component epoxy systems.

### **Principal Heating System**

The Proportioners consists of two (2) independent Material Heaters without internal seals. The PH-20 Heater has Three (3) Heating Elements per heater rated at 1,250 watts each giving the Proportioner a total heat of 7500 watts. The PHX-30 heater also has 3 Heating elements per heater rated at 1500 watts each giving the proportioner a total heat of 9000 watts. Each heater has the necessary controls and safety components for their precise operation. The Material Heater design allows a temperature differential ( $\Delta T$ ) of 58° F (15 C) and material application temperatures of up to 190° F (88 C).

### **Hose Heating System**

The system is designed with a 2 KVA Isolation Transformer that enables effective heating of up to a total hose length of 210 feet (63 m). The system includes an innovative hose heating concept in which the continuous braid tinned-copper jacket is distributed evenly around the circumference of the hose providing a uniform heating watt density and precise control of the material application temperature. This hose heating element design is extremely resistant to fatigue failure.

100% circumferential coverage produces the most uniform distribution of heat available.

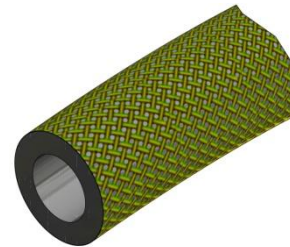

### **Double Acting Piston Metering Pumps**

The vertical double acting Pump Line is driven by a Hydraulic Cylinder. The in-line pump system with vertical piston pumps provides a constant volume and ratio on both the up stroke and down stroke.



# PH-20/PHX-20 Manual

## TECHNICAL SPECIFICATIONS

### Electrical

**Main Voltage:** \_\_\_\_\_ **3 x 208-230V, 50/60Hz**

Electrical Consumption: PH-20, 2000 PSI (2 x 3.75 kW Heaters) \_\_\_\_ 27 A @ 3 x 230V

Electrical Consumption: PHX-20, 3000 PSI (2 x 4.5 kW Heaters) \_\_\_\_ 32 A @ 3 x 230V

**Main Voltage:** \_\_\_\_\_ **1 x 208-230V, 50/60Hz**

Electrical Consumption: PH-20, 2000 PSI (2 x 3.75 kW Heaters) \_\_\_\_ 58 A @ 1 x 230V

Electrical Consumption: PHX-20, 3000 PSI (2 x 4.5 kW Heaters) \_\_\_\_ 65 A @ 1 x 230V

**Main Voltage:** \_\_\_\_\_ **3 x 380V, 50/60Hz**

Electrical Consumption: PH-20, 2000 PSI (2 x 3.75 kW Heaters) \_\_\_\_ 23 A @ 3 x 380V

Electrical Consumption: PHX-20, 3000 PSI (2 x 4.5 kW Heaters) \_\_\_\_ 27 A @ 3 x 380V

Material Heater Power: PH-20 (2 x 3.75 kW) \_\_\_\_\_ 7.5 kW

Material Heater Power: PHX-20 (2 x 4.5 kW) \_\_\_\_\_ 9 kW

Hose Transformer Power: \_\_\_\_\_ 2 KVA

Electrical Motor Power: \_\_\_\_\_ 3 hp



**CAUTION!** Inside the console, is a Terminal Strip for connecting the main power (wire not supplied) to the PH Series Proportioner. This electrical connection must be made only by a qualified electrician.

### Mechanical

Maximum working pressure PH-20 (with 123 pumps): \_\_\_\_\_ 2,000 psi, 138 Bar

Maximum working pressure PHX-20 (with 61 pumps): \_\_\_\_\_ 3,000 psi, 207 Bar

Maximum production ratio 1:1 PH-20 (with 123 pumps): \_\_\_\_\_ 20 lb/min 10 kg/min

Maximum production ratio 1:1 PHX-20 (with 61 pumps): \_\_\_\_\_ 1.3 gpm, 5.2 lpm

Minimum production: \_\_\_\_\_ 2 lb/min, 1 kg/min

Maximum hose length: \_\_\_\_\_ 210 ft, 63 m

Approximate weight (Hydraulic Tank empty): \_\_\_\_\_ 365 lbs, 110 kg

Approximate weight (Hydraulic Tank full @ \_\_\_\_\_ 12 gal (4.8 liters): 435 lbs, 130 kg

Dimensions: \_\_\_\_\_ 30in W x 26in D x 45in H, 76cm W x 66cm D x 114cm H





# PH-20/PHX-20 Manual

## DESCRIPTION

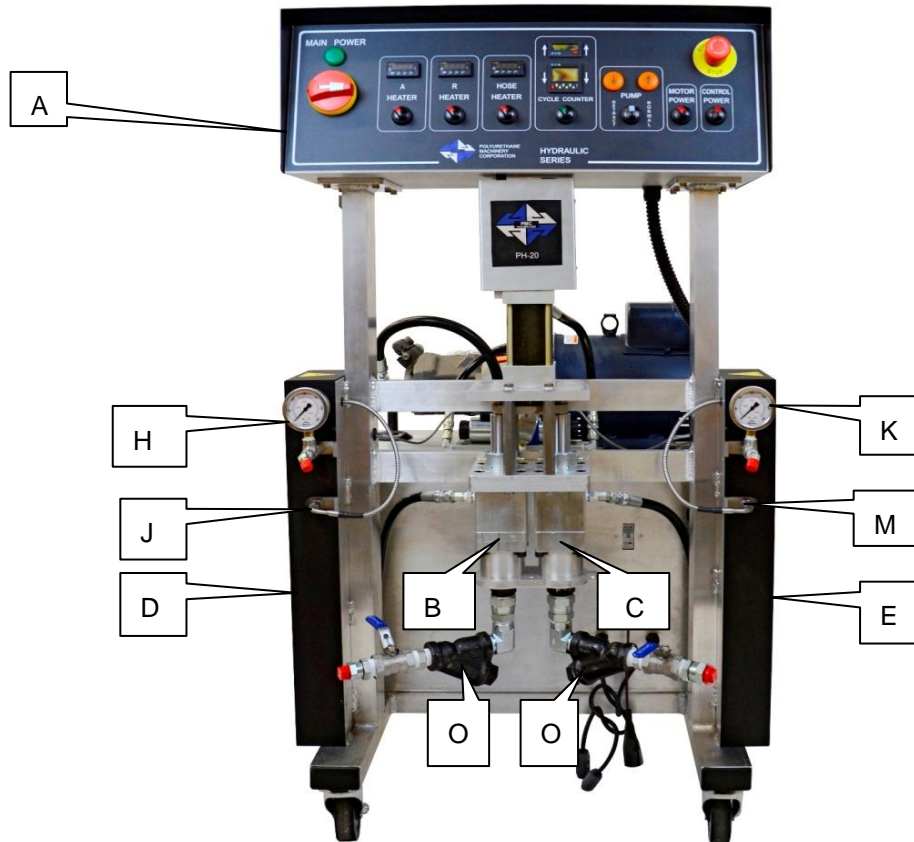

## ***PH-20/PHX-20 Proportioners***

### **A. Control Panel**

Controls and regulates the operation of the PH Series Proportioner.

### **B. Isocyanate (Iso, A) Metering Pump**

Meters the Isocyanate material.

### **C. Polyol (Poly, R) Metering Pump**

Meters the Polyol material.

### **D. Isocyanate (Iso, A) Heater**

Heats the incoming Isocyanate to a temperature set by the operator.

### **E. Polyol (Poly, R) Heater**

Heats the incoming Polyol to a temperature set by the operator.



# PH-20/PHX-20 Manual

## F. Hose Heating Transformer – Right side, inside of hydraulic tank

Supplies the required voltage for material Heated Hoses.



## G. Hydraulic Pressure Gage

Indicates the pressure in the Hydraulic Drive System.

## H. Isocyanate (Iso, A) Pressure Gage

Indicates the pressure in the Isocyanate system.

## I. Isocyanate (Iso, A) Safety Pressure Switch

Turns OFF the Directional Valve in the event of excessive pressure in the Isocyanate system.

## J. Isocyanate (Iso, A) Thermocouple

Provides temperature information of the Isocyanate to its Temperature Controller.

## K. Polyol (Poly, R) Pressure Gage

Indicates the pressure in the Polyol system.

## L. Polyol (Poly, R) Safety Pressure Switch

Turns OFF the Directional Valve in the event of excessive pressure in the Polyol system.

## M. Polyol (Poly, R) Thermocouple

Provides temperature information of the Polyol to its Temperature Controller.

## N. Hydraulic Pressure Control

Allows the pressure of the hydraulic system to be increased or decreased. Turn clockwise to increase the pressure and counterclockwise to decrease. To regulate the pressure of the hydraulic system, the NORMAL or RETRACT Pump Switch position must be selected.

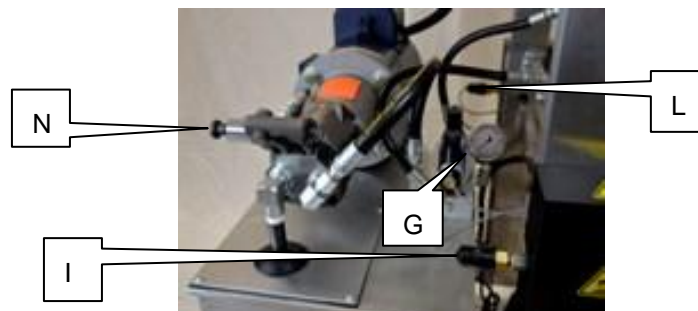



# PH-20/PHX-20 Manual

## O. Inlet Material Strainer

Screens (60 mesh) material from bulk supply.

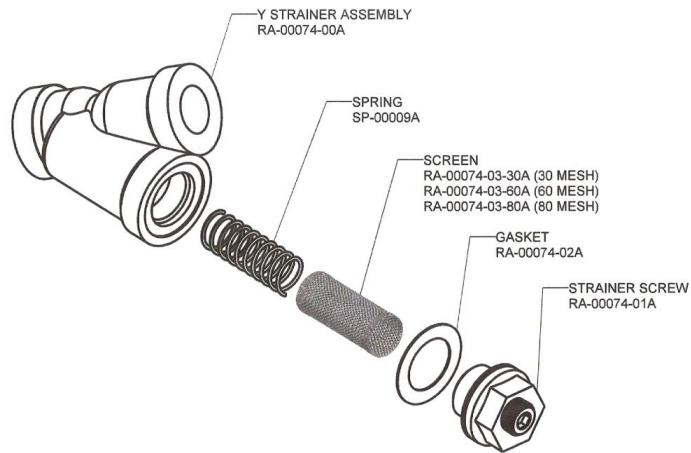



# PH-20/PHX-20 Manual

## DESCRIPTION (cont'd)

Figure 3

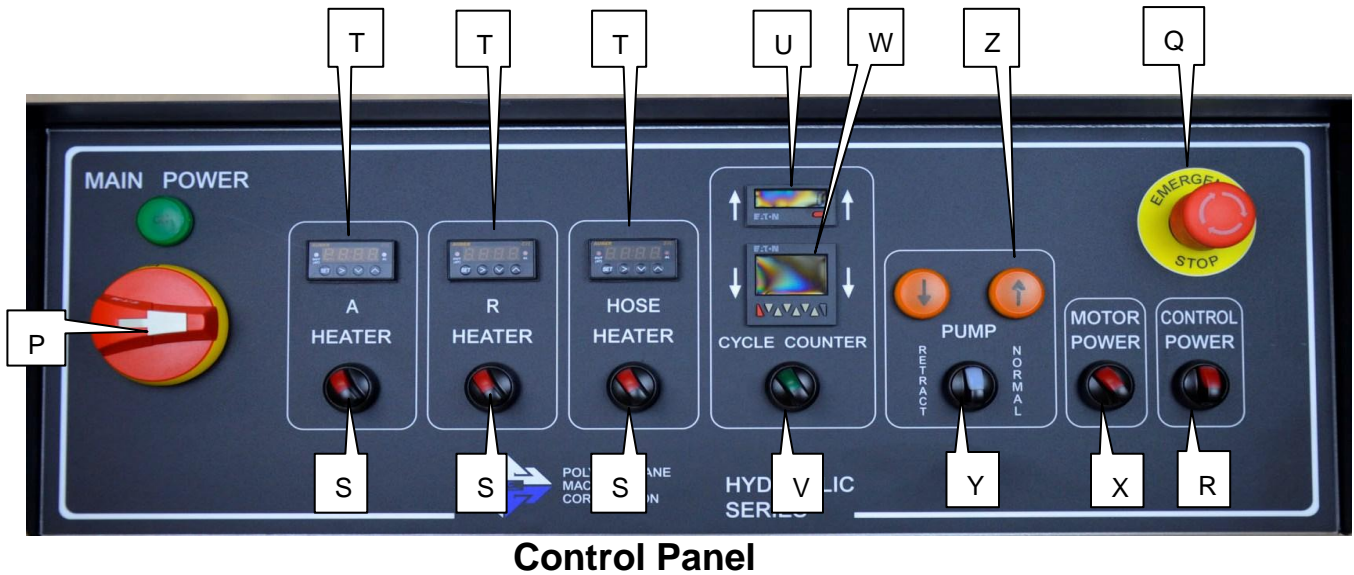

- P. Main Power** - Turns ON and OFF main power to the control panel. It must be turned ON for any operation to be performed with the unit. When turned ON, the red pilot will light.
- Q. Emergency Stop** - Interrupts the PH- Series control power circuit to stop all motion and heating.
- R. Control Power** - Turns ON and OFF the control power to the complete electrical circuit including Heaters and Hose Heater.
- S. Heater Temperature Switch - A (Iso), R (Poly), HOSE** - Turns ON and OFF power to the specific Heaters and Hose.
- T. Controllers** – Displays the temperature of the chemicals. See page 22 for detailed Temperature Controller instructions.
- U. Totalizer** – Indicates the number of pump cycles to calculate material usage.

| MODEL            | PUMP SIZE | CYCLES PER GALLON |
|------------------|-----------|-------------------|
| PH-20, 2000 PSI  | 123       | 23                |
| PHX-20, 3000 PSI | 61        | 47                |

- V. Auto Shut Down Switch** - Turns ON and OFF power to the Auto Shut Down unit.



# PH-20/PHX-20 Manual

## W. Auto Shut Down Counter

Used to set the amount of cycles required to prevent the chemical drums from running dry, the machine will shut down when the preset cycles expire. There is an on/off switch to activate this feature or deactivate and not use it, see page 24.

**X. Motor Switch** - Turns ON and OFF the Electric/Hydraulic Motor. When turned ON, the pilot will light. In the event of an overload of the Motor, pilot light will turn OFF and Motor will stop.

## Y. Pump Switch

**Off** - Removes power from the pump circuit. The directional indicator lights will not be lit.

**Normal** - Activates the normal operation of the machine. When the switch is ON, the directional light corresponding to the stroke direction will light.

**Retract** - Sets the Piston Rod of the Iso (A) metering pump to the down position and prevents the crystallization of Iso (A) on the Piston Rod. Press the RETRACT key every time the unit is stopped by the operator (see Shut-Down, page 25).

**Z. Direction Indicator Light** - Indicates the movement direction of the Metering Pumps. If excessive pressure is caused in the system, the pump circuit will be disabled and the directional lights will be OFF.



# PH-20/PHX-20 Manual

## INSTALLATION

**WARNING!** Use suitable protection and follow the recommendations in the Safety Information enclosed and provided by material suppliers when installing or working with the Proportioner.



*Inside the console is a Terminal Strip for connecting the incoming power cable (not supplied). The electrical connection of the Proportioner must be carried out by a qualified electrician.*

**NOTE!** To ensure the PH-20 Series Proportioner works correctly, the electrical supply must meet the specifications indicated on the Serial Number Placard affixed to the Electrical Console.

**CAUTION!** Make sure the power cable is disconnected from the main power source before connecting to the Terminal Strip in the Console.

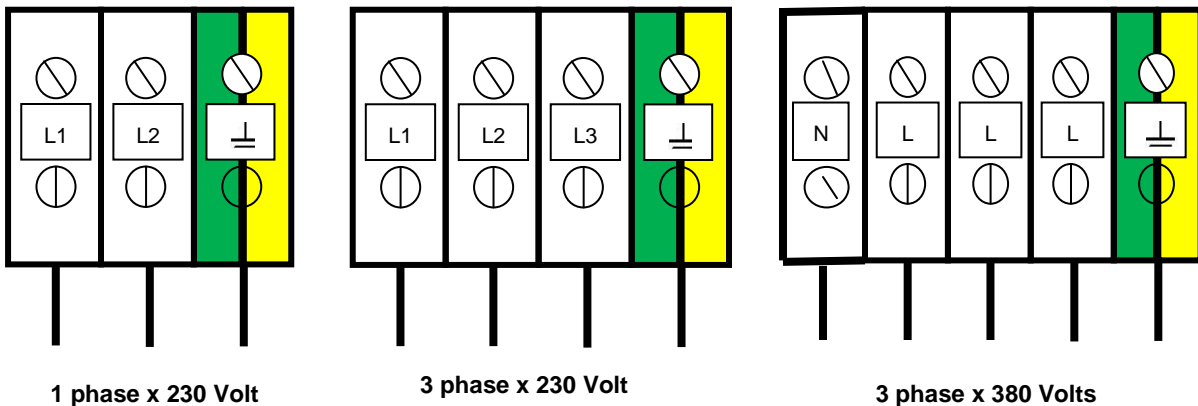

Follow the recommended procedure in the indicated order to install the Proportioner:

1. Insert the main power cable by passing it through the wire stop at the bottom of the Electrical Console and connect as shown in the above diagram.
2. Fill the reservoir with the recommended hydraulic oil. To fill remove the screws from the tank cover and rotate the cover, be careful not to damage the gasket. See page 47 for oil specifications.



Tank cover



# PH-20/PHX-20 Manual

***NOTE! Do not fill the tank to maximum capacity; Make sure the amount of hydraulic fluid is not more than 12 gal or 80% of the tank maximum capacity.***

3. Check the level of the hydraulic fluid in the Hydraulic Pump Case: Disconnect the Hydraulic Hose from the 90° fitting and remove Fitting from Hydraulic Case. Add fluid as required. Reattach Fitting and Hydraulic Hose. Turn the hydraulic pressure control knob counter clockwise until it stops, that is the lowest hydraulic pressure setting.



Check Fluid Level



Hydraulic Pressure control Knob



# PH-20/PHX-20 Manual

## INSTALLATION (cont'd)

### ENSURE THAT THE EMERGENCY (E-STOP) STOP IS NOT ENERGIZED

4. **Three-phase Proportioner Only:** Check the Electric Motor to ensure rotation is **clockwise**. **Remove the inspection cover from the motor bell housing** when viewing the end of the Electric Motor. A counter clockwise rotation indicates two of the incoming power leads need to be reversed.

**CAUTION!** Ensure Main Power switch is OFF and incoming power is locked OFF before reversing power leads.

Recheck the rotation before proceeding with Installation (3 Phase only).

## Heated Hose Installation

**CAUTION!** The material delivery Heated Hoses are color coded Red and Blue allowing the user to recognize them. The Red corresponds to the Isocyanate (Iso, A) and the Blue to the Polyol (Poly, R). To avoid connection errors the Coupling Connections of the Iso (A) and Poly (R) Heated Hoses are also different sizes, which makes it difficult to swap connections.

**NOTE!** The material delivery Heated Hoses are capped at the ends to prevent absorbing moisture. Do not remove caps until the Heated Hoses are going to be installed on the Proportioner.

1. Lay out all the Heated Hose assemblies end to end aligning the Iso "A" (red) and Poly "R" (blue) and connect the respective Coupling Connections using the appropriate sized open-end wrench after ensuring Heated Hose assemblies lay flat.

**CAUTION!** Take care to not cross-thread or over-tighten the Coupling Connections. Thread seal tape or compound is not required for this tapered seat Coupling Connections.

2. Connect the material Heated Hoses to the outlets of the respective Heaters i.e. Iso (A) Heated Hose to the Iso (A) Heater and the Poly (R) Heated Hose to the Poly (R) Heater ensuring Heated Hose assemblies lay flat.
3. Connect Air Hose Coupling Connections.





# PH-20/PHX-20 Manual

## INSTALLATION (cont'd)

### Heated Hose Installation (cont'd)

4. Connect the Heated Hose power wires to the “Fast-Lock” Connector coming from the Hose Heat Transformer as follows:
  - a. Loosen the Socket Head Set Screw to allow insertion of the Heated Hose electrical wire Terminal.
  - b. Insert the Terminal into the “Fast-Lock” Connector Body.
  - c. Securely tighten the Socket Head Set Screw.
  - d. Install electrical tape around Connector Body.



**NOTE!** A good practice is to add some dielectric grease (Permatex 67VR or equivalent) to the outside of the Terminal prior to insertion.

Repeat the above steps to connect the “Fast-Lock” Connectors that you will find on all Heated Hose power wire.

**CAUTION!** Ensure the proper mechanical and electrical connections of the Heated Hoses are made to avoid possible material leakage and Hose heat problems.

5. It is recommended the TSU be installed between the last section of Heated Hose and the Gun Whip. Carefully straighten the sensing wire, inserting it in the Iso (A) Heated Hose and tighten fluid fittings with appropriate sized open-end wrenches.

**CAUTION!** To protect the TSU sensor, you must pay special attention not to kink or excessively bend the Heated Hoses. Do not coil the Heated Hoses with a diameter of less than 4 feet.

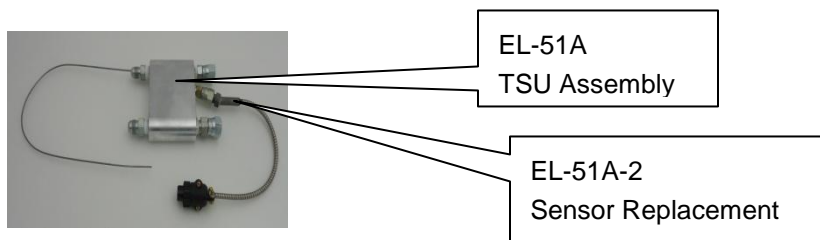

**CAUTION!** Connecting the TSU between the first and second section of Heated Hose results in the TSU sensing the material temperature exiting the Heater and not the inside of the Heated Hose near the Spray Gun.



# PH-20/PHX-20 Manual

## INSTALLATION (cont'd)

### Hose Heat Transformer

The Hose Heat Transformer offers the ability of connecting to different output voltages depending on the total length of the Heated Hose in use, maximizing the heating ability of the Heated Hose. The factory setting is 18 volts for use with 60 feet of Heated Hose. Before starting the Proportioner, ensure the setting matches the Heated Hose length installed. If Heated Hose sections are added or removed, the Tap setting should be changed to a setting which will limit the maximum amperage in the Heated Hose to 52 amps. The suggested settings are tabled below:

| Tap | Length |
|-----|--------|
| 72v | 210'   |
| 54v | 160'   |
| 36v | 110'   |
| 18v | 60'    |

Hose Heater Transformer

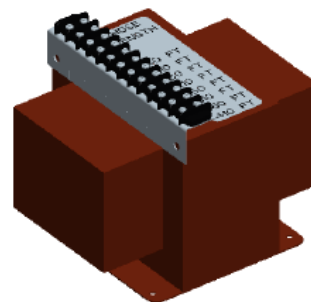

6. Ensure the Manual Valves are CLOSED and connect the Coupling Block to the Heated Gun Whip.

**CAUTION!** Excessive force closing or opening the Manual Valves may result in damage to the Manual Valves and/or Coupling Block.

7. Connect the Transfer Pump/ Heated Hose Assemblies/ Air Supply and Air Dryer systems as required. Review the Installation Instructions for each to ensure proper set-up and operation.
8. Install the Material Transfer Pumps as follows:

**WARNING!** If Transfer Pumps have been previously used, pay special attention to connect each Pump to “its” specific material. Inadvertently changing the Transfer Pumps will cause a chemical reaction rendering them useless.





# PH-20/PHX-20 Manual

## INSTALLATION (cont'd)

**NOTE!** Placing a tape of the same color as of the Material Delivery Hoses (red for the Iso (A), blue for the Poly (R)) on each Transfer Pump would be a good method for minimizing errors in connection.

- a. Make sure that the Inlet Valves on the Proportioner are closed.
- b. Connect one end of the Polyol (R) Material Delivery Hose ( $\frac{3}{4}$ " thread) to the Proportioner Polyol (R) Inlet Valve and the other end to the Polyol (R) Transfer Pump.
- c. Connect one end of the Iso (A) Material Delivery Hose ( $\frac{1}{2}$ " thread) to the Proportioner Iso (A) Inlet Valve and the other end to the Iso Transfer Pump.
- d. Connect the air hose to the Transfer Pumps after ensuring each Transfer Pump Shut-Off Valve is CLOSED.

**NOTE!** To avoid errors in connection, the Coupling connections of the Iso (A) and Poly (R) Material Delivery Hoses are different sizes, making it difficult to swap connections.

- e. Ground the Transfer Pump as recommend by the material supplier. The movement of product inside the Hoses can cause static electricity and produce electrical discharges.
- f. Connect air to the air line coming off the first section of hose (90-110 psi).



# PH-20/PHX-20 Manual

## PROPORTIONER PURGING

***WARNING!*** Use suitable Personal Protection Equipment (PPE) and follow the recommendations in the Safety Information provided by product suppliers when installing or working with the unit.

***WARNING!*** Do not turn the Temperature Controllers ON until the Proportioner Purging procedure is complete and the Primary Heaters and Heated Hoses are filled with material.

***NOTE!*** Before using the Proportioner it is necessary to purge the entire system, including Heated Hoses of mineral oil left over from Quality Control testing and air. The following procedure is also followed to purge air entrapped by running out of material in the supply Drum/Reservoirs resulting in a significant indicated material pressure imbalance as indicated by the Pressure Gauges and sprayed material.

1. Ensure the following before proceeding:
  - a. Air supply to Transfer Pumps is 90 - 110 psi.
  - b. Proportioner Inlet ball Valves are CLOSED.
  - c. All connections are tight.
  - d. Material should be stored to the material suppliers' recommended temperatures.
  - e. Spray gun coupling block is installed.
2. Slowly OPEN the Poly (R) Transfer Pump Air Shut-Off Valve allowing Pump to cycle slowly as it fills the Material Delivery Hose to the Proportioner. Check for leaks.
3. OPEN Poly (R) Coupling Block Manual Valve over a waste container.
4. Slowly OPEN Proportioner Poly (R) Inlet Valve allowing Transfer Pump to move material through the system. When all spitting of air stops and all traces of mineral oil have disappeared, CLOSE Poly (R) Coupling Block Manual Valve. Clean Coupling Block.
5. Repeat steps 2 to 4 for Iso (A) side.

***CAUTION!*** Properly dispose of all waste chemicals in accordance with all applicable local, state and federal codes. DO **NOT** turn on the Auto countdown switch.

6. Turn Hydraulic Pressure Control [ N, page10] full COUNTERCLOCKWISE.
7. Turn ON Main Power [P, page 12]. Green pilot will light.
8. Turn ON Control Power [R, page 12]. Switch will light.
9. Turn ON Motor Power [X, page 12]. Switch will light.



# PH-20/PHX-20 Manual

10. Set Pump Switch [Y, page 12] to NORMAL. Turn Hydraulic Pressure Control CLOCKWISE increasing **material pressure** to 400 psi. Both Material Pressure Gauges [H, K, page 9] should read the same. Check all Heated Hose Coupling connections for leakage.
11. Check all TSU and “Fast-Lock” connections for leaks.
12. Bundle all Heated Hose Connections ensuring that there are NO kinks in the TSU Cable or Air Hose. Wrap with Electrical Tape to securely hold all components in place and minimize places for bundle to snag onto job site protrusions.



# PH-20/PHX-20 Manual





## DIGITAL TEMPERATURE CONTROLLER

The PH-20/PHX-20 Series has three (3) Digital Temperature Controllers to manage the temperatures for the Primary Heaters and the Heated Hose. The Hose Heater Controller is programmed different from the heater Controllers and therefore not interchangeable with them.

**WARNING!** Do not turn the Temperature Controllers ON until the Proportioner Purging procedure is complete and the Primary Heaters and Heated Hoses are filled with material.

1. Ensure Main Power [P, page 12] and Control Power [R, page 12] is ON.



2. Press and release  or  button. The display will flash and indicate its current set point.
3. Press and hold the  or  to **increase** or **decrease** the material temperature set-point to the desired value as determined by the material supplier or application conditions.
4. Once the set point is entered the controller will go back to ambient temperature on its own.(5-8 seconds)

**WARNING!** The Controllers are factory programmed and are not field re-programmable. If a problem is encountered, contact PMC Technical Service. Do not attempt to change any of the programmed parameters. Do not substitute a Controller from an alternate supplier as its use may result in equipment damage and/or bodily injury.

**NOTE!** The Temperature Controller normally displays the actual material temperature. When lit, the red “OUT” display in the upper left indicates power is being sent to the Heater. The “OUT” display goes out when the material temperature has reached its set-point. The “OUT” display will continue to cycle on and off indicating the Controller is maintaining the material temperature set-point.



# PH-20/PHX-20 Manual

## **START-UP**

**NOTE!** Follow the recommended procedure in the order shown.

**CAUTION!** The Start-up procedures assume that all of steps in Proportioner purging have been performed and no problems found.

1. Check the hydraulic fluid level and service as required.
2. Make sure the materials have been stored at the manufacturer's recommended temperature. Ask your material supplier for information (Material Data Sheet) on the minimum storage temperature.
3. Y-Strainer screens should be checked routinely.
4. Connect air supply to the two Transfer Pumps and ensure Air Valves are in the full OPEN position. OPEN both Proportioner Material Inlet Ball Valves.

**CAUTION!** Remove all Heated Hose sections from coiled storage and lay flat to eliminate heat build-up and possible Heated Hose failure.

5. Turn ON Main Power [P page 12].
6. Turn ON Control Power [R, page 12].
7. Turn ON Hose [S, page 12]. Heater and confirm material set-point temperature as recommended by the material supplier or application conditions.

**CAUTION!** To avoid excessive pressure in the Proportioner, wait for the Hose Heater to reach its set-point temperature before continuing.

8. Turn ON each Primary Heater and confirm material set-point temperature as required by the material supplier or application conditions has been reached.
9. Turn ON Motor Power [X, page 12].
10. Set Pump Switch [Y, page 12] to NORMAL. One of the Directional Indicator Lights [Z, page 12] will light indicating Metering Pump direction and the Metering Pump Shafts will begin to move.

### **NOTE!**

- a. The Material Pressure Gauges [H, K, page 9] should be approximately equal and remain constant throughout Metering Pump cycle. If not, refer to Trouble Shooting section.
  - b. Directional Indicator Lights must indicate Metering Pump direction when Pump Switch is in the NORMAL position. If not, refer to Trouble Shooting section.
11. Using the Hydraulic Pressure Control, adjust to the required stall pressure<sup>①</sup> and check each Material Pressure Gauge.

**① Stall pressure: When materials are at recommend application temperature and Metering Pumps are pressurized but not moving. This pressure is normally 100 – 200 psi greater than the developed spray pressure as recommended by the material supplier.**



# PH-20/PHX-20 Manual

## 12. AUTO SHUT DOWN COUNTER

**If this function is not needed leave it in the off position.**

To set the Auto Shut Down Counter:

- a. Turn the switch to the on position, the green light will illuminate.
- b. Insert the number of cycles desired to disable the PH machine by pushing in on the white triangles to set the cycle count. Push in on the red button until the data is replicated on the top row, the top row will count down. Figure B

| MODEL            | CYCLES PER GALLON              |
|------------------|--------------------------------|
| PH-20, 2000 PSI  | 123 pumps 23 cycles = 1 gallon |
| PHX-20, 3000 PSI | 61 pumps 47 cycles = 1 gallon  |

- c. When the counter counts down to zero the machine will stop and the pump directional light will be off, push in on the red button to reset. Figure C



Figure A



Figure B

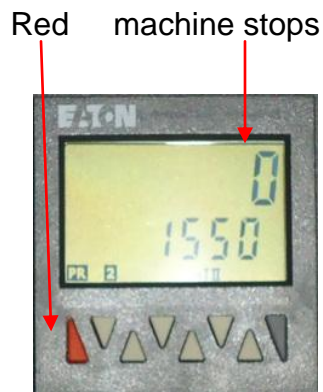

Figure C

13. Proceed with Installation and Start-up of the Spray Gun as per the Gun manual.





# PH-20/PHX-20 Manual

## **SHUT-DOWN**

Follow the recommended procedure in the indicated order for Proportioner temporary shut-down such as **lunch breaks**.

1. Set Pump Switch [Y, page 12] to OFF position.
2. Turn each Heater OFF. Hose Heater should remain ON. Never leave Proportioner ON if unattended.
3. CLOSE Spray Gun Manual Valves.

**CAUTION!** Excessive force opening or closing the Manual Valves may result in damage to the Manual Valves and/or Coupling Block.

Follow the recommended procedure in the indicated order for Proportioner shut-down when work is **stopped for the day**.

1. Set the Pump Switch [Y, page 12] to RETRACT.
2. Spray off the application surface until Material Pressure Gauges [H, K, page 9] readings begin to fall.

**CAUTION!** To avoid possible Proportioning Pump Seal weepage, and moisture vapor drive into the Heated Hoses, the system pressure should not be reduced to zero. It is recommended to lower the system pressure to a minimum of 400 psi.

3. CLOSE the Spray Gun Coupling Block Manual Valves.

**CAUTION!** Excessive force opening or closing the Manual Valves may result in damage to the Manual Valves and/or Coupling Block.

4. Turn OFF Motor Power [P, page 12].
4. Turn OFF the A and R Heaters and Hose Heater [S, page 12].
5. Turn OFF the Control Power [R, page 12].
6. Turn OFF the Auto Shut down switch [V, page 12].
7. Turn OFF the Main Power [P, page 12].
8. Apply grease to the “A” side grease fitting located on the pumps packing retainer.
9. Disconnect the air supply to the two Transfer Pumps and CLOSE the Proportioner Material Inlet Valves.



# PH-20/PHX-20 Manual

## TROUBLESHOOTING

The PH Series Proportioner has been designed and built to withstand severe working conditions with a high degree of reliability, provided that it is used in a suitable application by a properly trained operator. This chapter contains information on possible faults that may interrupt the operation of the PH Series Proportioner. The information provided will serve as a guideline to detect and resolve problems. In any case, feel free to contact the Technical Service group of PMC, where a qualified technician will advise you.

**WARNING:** Only qualified personnel should perform troubleshooting, unqualified personnel may cause damage to the unit and put the operator at risk.



***To prevent possible injury caused by incorrect handling of the raw materials and solvents used in the process, carefully read the safety data sheet provided by your supplier.***

***Deal with the waste caused according to current regulations.***

***To avoid damage caused by the impact of pressurized fluids, do not open any connection or perform maintenance work on components subject to pressure until the pressure has been completely eliminated.***

***Use suitable protection when operating, maintaining or being present in the area where the equipment is functioning. This includes, but is not limited to, the use of protective goggles, gloves, shoes and safety clothing and breathing equipment.***

***The equipment includes components that reach high temperatures and can cause burns. Hot parts of the equipment must not be handled or touched until they have cooled completely.***

***To prevent serious injury through crushing or amputation, do not work with the equipment without the safety guards installed on the moving parts. Make sure that all the safety guards are correctly reinstalled at the end of the repair or maintenance work of the equipment.***



# PH-20/PHX-20 Manual

## TROUBLESHOOTING

### Heaters

**WARNING!** Only qualified personnel should perform troubleshooting, unqualified personnel may cause damage to the unit and put the operator at risk. The Heaters are components that reach high temperatures; you must wait until they cool before handling.

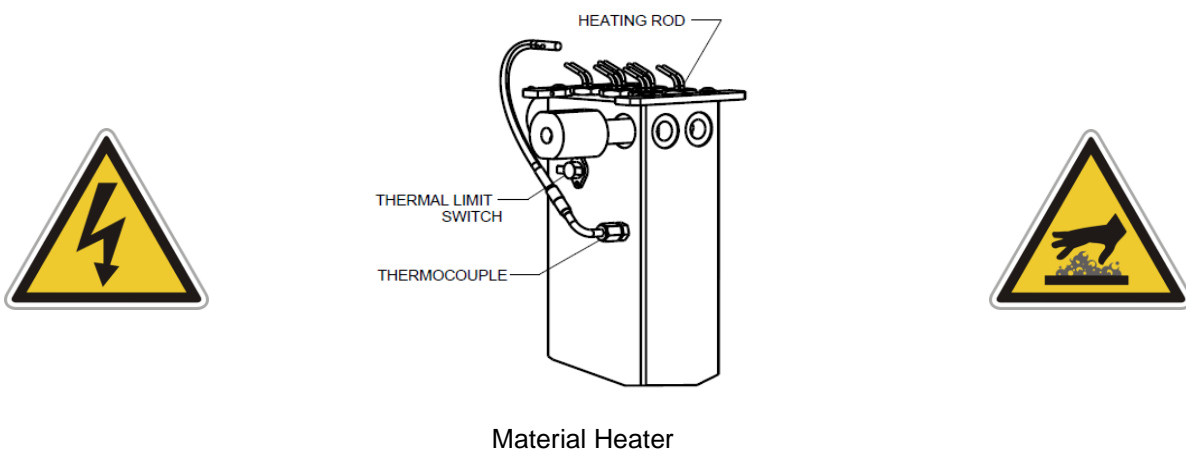

**NOTE !** The Thermal Limit Switch is a safety switch in contact with the Heater Body. If the surface temperature exceeds 220° F the Limit Switch will shut off the Heater power. The Limit Switch will not re-set until the temperature in the Heater is below 190° F. The system is designed that in case of an over temperature a contactor located in the console will open disabling power to both Heaters and the Hose.

Follow the recommended procedure in the indicated order to solve the problem and avoid unnecessary repairs. Make sure all Switches are in the correct position and Indicator Lights ON before determining the existence of a fault.



# PH-20/PHX-20 Manual

## TROUBLESHOOTING

### Heaters (cont'd)

#### PROBLEM

Primary heater does not heat and the display on the controller shows ambient temperature.

#### SOLUTIONS

1. Check that the light on the on/off switch is lit when the heater is turned on, if not replace the switch.

**If the light is on move to the next step.**

2. Check the heater breaker in the main console, reset the breaker, if it continues to trip, wrap an Amp Clamp around one of the wires coming off the breaker. If the Amperage reading does not exceed the rating of the breaker, the breaker needs to be replaced. If the breaker draws more than its rating the most likely cause is that one or more of the fire rods located in the heater are shorted.

**If the breaker is not tripped move on to the next step.**

3. Open the console top and locate the solid state relays for the heaters, looking over the console top from the front of the machine. There are two relay to the left bottom of the console, the one to the far left is for the "A" heater and the one to the right is for the "R" heater. With the heater on look to see if a LED light is lit on the relay.

**If there is no LED light on the solid state relay move to the next step.**

4. With a DC volt meter read across position A1 and A2 on the solid state relay (smaller wires) if you have a reading of 4-6 volts DC and the AC reading across L1 and L2 (Heavy wires) reads 208-230 volts AC replace the solid state relay. With 4-6 volts DC at A1 and A2 the proper reading should be 1 volt AC across L1 and L2. A defective over temperature switch will open a contactor disabling both Heaters and the Hose.

**If there is no DC voltage to the relay, move to the next step.**

5. Using a DC volt meter measure across position 9 and 10 on the back of the heater controller. This is the output of the controller and sends power to the solid state relay; your reading will be 4-6 volts DC. If there is no reading check to make sure that the set temperature of the controller is above the actual temperature reading on the controller. Before replacing the controller read across position 1 and 2 to make sure that the controller is powered up, your reading will be 208 to 230 volts AC. If there is no voltage detected; check for loose wires or a malfunction of the heater circuit breaker.



# PH-20/PHX-20 Manual

## TROUBLESHOOTING

### Heaters (cont'd)

#### PROBLEM

Primary heater does not heat and the display on the controller shows an error message  
EEEE

#### SOLUTIONS

1. Check position 6 and 7 on the heater controller for loose wires.

**If the wires are tight move to the next step.**

2. Remove the heater cover and check that the thermocouple wires are secure to the harness going up to the controller.

**If there are no loose connections replace the heater thermocouple.**

#### PROBLEM

Primary heater controller shows excessive temperature and the circuit has turned off.

**CAUTION!** The heater must be allowed to cool down before continuing.

#### SOLUTIONS

1. Set the controller set point at least 20 degrees lower than the temperature shown on the controller. Briefly turn on the heater and look for the LED light on the solid state relay to be on.

**If the light is on replace the controller.**

**If the light is off replace the solid state relay.**

#### PROBLEM

Primary heater Temperature drops excessively while spraying.

#### SOLUTIONS

1. Temperature of the chemical in the containers is too cold.
2. Exceeding the flow rate specification of the machine.
3. Disconnect power to the machine. One or more of the fire rods in the heater have malfunctioned. Remove the heater cover and disconnect the wires to measure the resistance across each rod. Installing a smaller mixing chamber in the gun may allow you to spray until a new rod(s) is installed.



# PH-20/PHX-20 Manual

## TROUBLESHOOTING

**CAUTION!** If the rod that is used in conjunction with the thermocouple is defective do not operate the heater until the rod is replaced.

| MODEL            | INDIVIDUAL OHMS MEASUREMENT |         |
|------------------|-----------------------------|---------|
| PH-20, 2000 PSI  | 1250 WATT                   | 37 OHMS |
| PHX-20, 3000 PSI | 1500 WATT                   | 31 OHMS |

### Hydraulic Drive System

Follow the recommended procedure in the indicated order to solve the problem and avoid unnecessary repairs. Make sure all Switches are in the correct position and Indicator Lights ON before determining the existence of a fault.

**WARNING!** Before correcting any kind of defect, make sure the Main Power Switch is OFF and incoming power is locked OFF. NEVER access the inside of the Control Panel with the Proportioner power supply ON. The Hydraulic Unit is a component that works under pressure. Do not open any connection or carry out maintenance on components subject to pressure until all pressure has been bled to zero.

**CAUTION!** Do not attempt to reset the Motor Contactor more than twice. Failure of the Motor Contactor safety mechanism will occur and the Contactor will become inoperable and/or the Motor damaged. The cause of the problem must be determined and corrected.



# PH-20/PHX-20 Manual

## PROBLEM

Hydraulic Pump does not develop pressure and the electric motor is not running.

## SOLUTIONS

### 1. Motor Contactor Safety or Motor Breaker

The Electric Motor is protected from excessive current by an Overload Safety Switch. After allowing the Motor to cool, open the Control Panel and reset Motor Contactor Safety.



Motor Contactor

## PROBLEM

Hydraulic Pump does not develop pressure

## SOLUTIONS

### 1. Hydraulic Power Package

**NOTE!** Hydraulic pressure is not generated if the Motor Power Switch [X, page 12] is OFF or the Pump Switch [Y, page 12] is in the OFF position.

With the Pump Switch in the NORMAL position, the failure of the Hydraulic Pump to develop pressure is loss of pump suction (prime). To ensure positive prime, check the following:

- a) Motor rotation (page 16).
- b) Hydraulic Reservoir is filled to the correct level (page 15).
- c) Hydraulic Pump Case is filled with the proper hydraulic fluid (page 47).
- d) Loose Inlet Plumbing: Check that all inlet plumbing to Hydraulic Pump is tight ensuring no air leakage into the hydraulic system.



# PH-20/PHX-20 Manual

## TROUBLESHOOTING

### Hydraulic Drive System (cont'd)

#### PROBLEM

Low or zero hydraulic pressure with unusual Hydraulic Pump noises

#### SOLUTIONS

1. The use of an incorrect hydraulic fluid can result in unusual noises from the pump, excessive wear and moisture absorption. Ensure the hydraulic oil used is from the list on page 47. In addition to the above, continuous excessive hydraulic oil temperature as well as failure to change the hydraulic oil on a yearly basis will cause the oil to fail and result in excessive Hydraulic Pump wear and unusual noises.
2. Loose Inlet Plumbing: Check that all inlet plumbing to Hydraulic Pump is tight ensuring no air leakage into the hydraulic system.





# PH-20/PHX-20 Manual

## TROUBLESHOOTING

### Metering Pump Line

Follow the recommended procedure in the indicated order to solve the problem and avoid unnecessary repairs. Make sure all Switches are in the correct position and Indicator Lights ON before determining the existence of a fault.

#### PROBLEM

Metering pumps do not change direction and the pressures on both of chemical gauges are lower than normal.

#### SOLUTIONS

1. The top of the hydraulic piston shaft actuates a reversing switch at the end of the stroke. The reversing switch in turn actuates the appropriate Directional Valve Solenoid.

Failure to make contact with the reversing Switch may be caused by:

- ✓ Deformation of the Reversing bushing or a bent or loose reversing switch mounting plate.
- ✓ Foreign material preventing the Reversing bushing from contacting the Switch.  
**If this is not the problem go to the next step**

2. Passing of the Reversing bushing beyond the switch may be caused by:

- ✓ Failure of the Switch and related components on the side of the over-run.
- ✓ Failure of a component of the Direction Valve.
- ✓ Mounting Plate is bent or is out of adjustment.

3. Failure of the reversing switch or reversing valve coil

- ✓ If the pump directional indicator light is on check the reversing valve coil, each coil should read approximately 19 ohms.
- ✓ If the pump directional indicator light is off and there is no hydraulic pressure check for a defective reversing switch.



# PH-20/PHX-20 Manual

## TROUBLESHOOTING

### Metering Pump Line (cont'd)

IF THE DIRECTIONAL LIGHT IS **OFF** PROCEED BELOW

BEFORE TROUBLESHOOTING THE REVERSING SWITCH PLATE MUST BE MOVED AWAY FROM THE SWITCH.

- a) Bleed the down the chemical pressures.
- b) Ensure Pump Switch [Y, page 12] is **OFF**.
- c) Turn on the motor [X, page 12].
- d) Go to the Directional Valve and locate the Actuation Coils. Located in the middle of each coil is small round tab that can be pushed in to manually shift the spool to move the pumps. If the Reversing bushing is all the way to the bottom push in on the right side coil. If it's all the way to the top push in on the left side coil.

**TURN OFF ALL ELECTRICAL POWER TO THE MACHINE.**

Using an ohm meter check the reversing switch

## TROUBLESHOOTING

### Metering Pump Line (cont'd)

#### 4. Safety Pressure Switch

Each Metering Pump has a Safety Pressure Switch [I, L, page 9] set to 2,200 psi. for #123 pumps, 3,200 psi for #61 pumps. When the material system reaches this pressure, the Safety Pressure Switch will remove power from the Directional Valve and Direction Indicator Lights [Y, page 11]. Lack of Direction Indicator Lights along with high pressure indicated on one or both of the material Pressure Gauges [H, K] is a indication of a over-pressure condition. The Safety Pressure Switches are a momentary design; when the pressure bleeds off the Metering Pump Line will resume normal operation. However, the cause of the over-pressure should be determined and corrected. The three most common causes are:

- a) Cavitation of the Metering Pump on the **low** pressure side
- b) Causing high pressure on the opposite side.
- c) A restriction in the Spray Gun on the **high** pressure side.

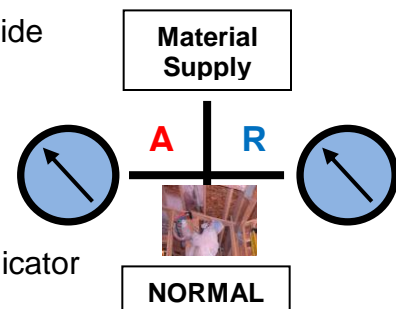

#### 5. Pressure/Material Imbalance

In summary troubleshooting this problem requires the applicator to:

- a) Know what the NORMAL spray pressures are for the application in progress.



# PH-20/PHX-20 Manual

- b) Determine what material is NOT exiting the Mixing Chamber.
- c) Read the Pressure Gauge on the problem side and interpret the reading.
- d) In this example a lack of Iso (A) with fluctuating LOW pressure on the Iso (A) side indicates the Metering Pump **is not** developing sufficient pressure or material volume; **Cavitation.**

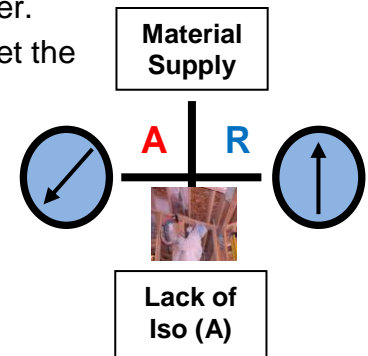

In this example a lack of Poly (R) with HIGH pressure on the Poly (R) side indicates the Metering Pump **is** developing sufficient pressure; a stoppage after the Pressure Gauge is not allowing the material to exit the Spray Gun.  
**Check Spray Gun for a blockage.**

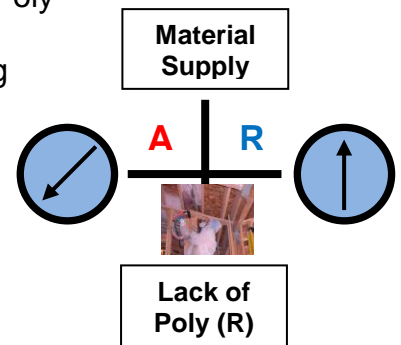

## 6. Cavitation

Cavitation occurs when the Metering Pump [B, or C, page 9] requires a larger volume of material than the supply system (Transfer Pump) can furnish. This creates a "void" of material in the Metering Pump. The most common causes of cavitation are:

- a) Material temperature **too low** causing increased material viscosity resulting in the inability of the Transfer Pump to maintain sufficient supply to the Metering Pump. This is most common with today's blown systems. Ensure the **material** temperature in the drums is no lower than the material suppliers' recommendation.
- b) Failure to vent the material drum while drawing material out with the Transfer Pump causes a vacuum and cavitation in the Transfer Pump. Ensure the drum is vented to the atmosphere or a Desiccated Air Dyer Kit is installed as recommended by the material supplier.
- c) Air volume insufficient for Transfer Pump or Transfer Pump Air Valve partially closed will limit the ability of the Transfer Pump to operate at its maximum capability.
- d) Inlet Material Screen [O, page 11] obstructed (See **MAINTENANCE** section).
- e) Metering Pump Inlet Ball does not seat properly allowing material to flow back into the Material Delivery Hose when the Metering Pump is on the "Discharge" stroke. This causes the volume of material on that Metering Pump to be less on the discharge stroke resulting in intermittent off-ratio material and Pressure Gauge fluctuation.



# PH-20/PHX-20 Manual

## 7. Pressure Loss: Discharge/Inlet Ball

Simultaneous observation of the material Pressure Gauge [H, K, page 9] and Direction Indicator Light [Z page 12] is necessary to determine which direction the Metering Pump fails to maintain pressure. Refer to the chart to determine problem:

|                              | ↓ Directional Indicator Light<br>ON           | ↑ Directional Indicator Light<br>ON          |
|------------------------------|---|--|
| Iso Pressure Gauge<br>FALLS  | Iso Inlet Ball does not seat<br>properly      | Iso Discharge Ball does not<br>seat properly |
| Poly Pressure Gauge<br>FALLS | Poly Discharge Ball does<br>not seat properly | Poly Inlet Ball does not<br>seat properly    |

In most cases the cause of a leaking Inlet/Discharge Ball is foreign material preventing the Ball from seating properly. If the above steps do not resolve the problem, replace the appropriate Ball, Ball Seat.

For service see [MAINTENANCE/Metering Pump Line/page 44](#).



# PH-20/PHX-20 Manual

## TROUBLESHOOTING

### Hose Heating

**WARNING!** Before correcting any kind of defect, make sure the Main Power Switch is OFF and incoming power is locked OFF. NEVER access the inside of the Control Panel with the Proportioner power supply ON. The Heated Hose are components which reach high temperatures; you must wait until they have cooled before handling.

**Follow the recommended procedure in the indicated order to solve the problem and avoid unnecessary repairs. Make sure all Switches are in the correct position and Indicator Lights ON before determining the existence of a fault.**

**CAUTION!** All electrical testing must be done by a qualified electrician.

### PROBLEM

A- Heated hose does not heat and the display on the controller shows ambient temperature.

### SOLUTIONS

1. Check that the light on the on/off switch is lit when the heater is turned on, if not replace the switch.

**If the light is on move on to the next step.**

2. Check the Hose Heat breaker in the main console reset the breaker. If it continues to trip wrap an Amp Clamp around one of the wires coming off the breaker. If it does not draw more than the rated value of the breaker, the breaker needs to be replaced.

**If the breaker is not tripped move on to the next step.**

3. Check the circuit breaker mounted on the transformer; reset the breaker if it continues to trip wrap an Amp Clamp around one of the wires from the transformer going to the heated hose if it does not draw more than the rated value of the breaker, the breaker needs to be replaced.

**If the AMP draw is less than the rated value move on to the next step.**

4. Check that the tap setting on the transformer is set for the proper hose length.

**If it is set correctly move to the next step.**

5. Look at the two lights located on the front of the transformer. If the voltage light is lit and the AMP light is off the problem could in the heated hoses. If the voltage light is on there is power to the primary side of the transformer. To check the secondary side of the transformer you must take an AC volt reading across the two leads coming out of the transformer that are connected to the "A" and "R" hose leads. If you are reading voltage (your volt reading will vary depending on what tap setting is used) most likely the problem is in the heated hose. Either a connector has come loose or there is a broken wire.



# PH-20/PHX-20 Manual

## Hose Heating (cont'd)

Because the gun whip takes the most abuse it is most likely that the whip has failed. Disconnect the crossover wires on the machine end of the whip hose and connect the two wires together coming off the 50' section, turn on the hose heat and see if the hose heat circuit is operating, if so replace the whip. To take a continuity reading through the heated hose one of the leads from the transformer to the "A" or "R" heated hose must be disconnected.

**If no voltage is coming out of the transformer to the heated hose move on to the next step.**

6. Open the console top and locate the solid state relay for the hose circuit, looking over the console top (front of machine) it is the relay to the right. With the hose turned on and there is a LED light lit on the relay take a volt meter set on DC and measure across position A1 and A2 your Reading should be 24 volts, then take an AC volts measurement across position L1 and L2 (heavy wires). With the relay functioning properly you should have a 1 volt Reading, if the Reading is 18 to 90 volts AC the relay has malfunctioned and needs to be replaced. If the AC Reading across L1 and L2 is .025 volts check the over temperature switches in the heaters. A defective over temperature switch will open a contactor disabling both Heaters and the Hose.

**If there is no light on the solid state relay move to the next step.**

7. Using a DC volt meter measure across position 5 and 6 on the back of the hose controller this is the output of the controller and sends power to the solid state relay, your reading will be **4-6 volts DC** if there is no voltage check to make sure that the set temperature of the controller is above ambient temperature. Before replacing the controller read across position 1 and 2 to make sure that the controller is powered up, your reading will be 208 to 230 volts AC.

**If there is no DC voltage to the relay move to the next step.**

## PROBLEM

Hose does not heat and the display on the controller shows an error message (EEEE).

## SOLUTIONS

1. Check position 6 and 7 on the heater controller for loose wires.

**If the wires are tight move to the next step.**

2. Remove the transformer cover and check that the thermocouple wires are secure to the harness going up to the controller. If there are no loose connections disconnect the wire from the TSU and connect it directly to the thermocouple harness coming out of the hose transformer.

**If the controller still shows the error code replace the hose thermocouple.**



# PH-20/PHX-20 Manual

## TROUBLESHOOTING

### Hose Heating (cont'd)

If the error code goes away and temperature is now shown on the display of the controller then all the TSU harnesses from the TSU to the transformer need to be checked for loose connectors or one or more of the harnesses are defective.

#### PROBLEM

Heated hose controller shows excessive temperature

#### SOLUTIONS

1. Set the controller set point at least 20 degrees lower than the temperature shown on the controller. Briefly turn on the hose and look for the led light on the solid state relay to be on.

**If the light is on replace the controller.**

**If the light is off replace the solid state relay.**

#### PROBLEM

Hose will heat but does not come up to set temperature.

#### SOLUTIONS

1. Check the tap setting on the transformer to ensure that the correct position has been selected for the length of hose being used. Depending on the machines incoming voltage you may have to move the tap setting higher (up one).

**CAUTION!** Do not exceed the trip value of the transformer hose breaker.

**WARNING!** Before correcting any kind of defect, make sure the Main Power Switch is OFF and incoming power is locked OFF. NEVER access the inside of the Control Panel with the Proportioner power supply ON.



# PH-20/PHX-20 Manual

## TROUBLESHOOTING

### Hose Heating (cont'd)

#### PROBLEM

Hose does not heat and the display on the controller shows an error message.

#### SOLUTIONS

1. Check position 9 and 10 on the heater controller for loose wires.

**If the wires are tight move to the next step.**

2. Remove the transformer cover and check that the thermocouple wires are secure to the harness going up to the controller. If there are no loose connections disconnect the wire from the TSU and connect it directly to the thermocouple harness coming out of the hose transformer.

**If the controller still shows the error code replace the hose thermocouple.**

**If the error code goes away and temperature is now shown on the display of the controller then all the TSU harnesses from the TSU to the transformer need to be checked for loose connectors or one or more of the harnesses are defective.**





# PH-20/PHX-20 Manual

## MAINTENANCE

To achieve maximum output from the PH Series Proportioner, a daily or regular maintenance schedule is required.



***To prevent possible bodily harm caused by incorrect handling of the raw materials and solvents used in the process, carefully read the safety information provided by your supplier.***

***Deal with the waste created according to current regulations.***



***Disconnect the unit from the power supply before carrying out any operation inside the electrical console.***

***The electrical maintenance of the machine must only be performed by a qualified electrician.***



***To avoid damage caused by the impact of pressurized fluids, do not open any connection or perform maintenance work on components subject to pressure until the pressures have been completely eliminated.***



***Use suitable protection when operating, maintaining or remaining in the operating area of the unit. This includes, but is not limited to, the use of masks, protective goggles, gloves, shoes and safety clothing.***



***The unit includes components that reach temperature that are liable to cause burns. The hot parts of the unit must not be handled until they have cooled.***



***To prevent serious harm by crushing or loss of limbs, do not work with the unit without the safety duly installed on all moving parts. Make sure that all of the safety protections are correctly fitted after all repair or maintenance work.***

**CAUTION!** All repairs performed by unqualified personnel or the use of parts other than supplied by PMC may cause damage to the unit and put the operator at risk.



# PH-20/PHX-20 Manual

## MAINTENANCE

### **Inlet Material Screens [O, page 9]**

Inspection of the Inlet Material Screens on a daily basis is no longer necessary as long as the following conditions are met.

1. Material drums are stored within the recommended material storage temperature range and drums are not opened prior to installing the Proportioner Material Transfer Drum Pumps.
2. Desiccated air dryers are used to dry replacement air as material is removed from the drums to the Proportioner.
3. Consolidation of old material into a common drum for use is minimized especially the Iso (A).

If the above conditions are met, inspection of the Inlet Material Screens may be done on a **bi-weekly** basis.

**NOTE!** Inspect and clean Inlet Material Screens before Proportioner start-up. They should not be cleaned after the days operation as the Proportioner should be purged (see page 18) immediately after inspection and cleaning. This is to reduce the risk of moisture contamination, contamination through the reaction with the solvent used in the cleaning operation and cross-over at the Spray Gun due to air entrapment.

To check the Inlet Material Screens, proceed as follows:

**CAUTION!** Make sure the Main Power Switch is OFF and incoming power is locked OFF.

1. CLOSE the Poly (R) Proportioner Inlet Valve.
2. Place a suitable container under the Material Inlet Strainer to collect the residual material. Carefully loosen the Strainer Plug allowing the material to drain into the container.
3. Completely unscrew the Strainer Screw.
4. Remove the Seal, Spring and Screen and clean them with a suitable solvent. Dry the parts and ensure the Screen is not obstructed. Replace or clean the Screen if more than 20% of the Screen surface is obstructed by residue.

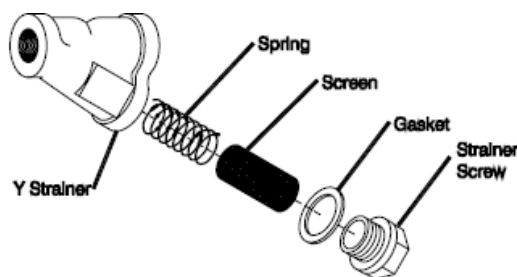

Material Inlet Strainer



# PH-20/PHX-20 Manual

## MAINTENANCE

### **Inlet Material Screens [O] (cont'd)**

5. Reinstall the Screen, Spring and Seal. Screw on the Strainer Screw and screw in Plug.
6. OPEN the Poly (R) Proportioner Inlet Valve, pressurize the Material Transfer Pump, check for leaks and wipe Y-strainer clean.
7. Repeat above for the Iso (A) side.
8. Proceed with Proportioner Purging operation (page 20).

### **Hydraulic Drive System**

***WARNING!*** Before performing any maintenance, make sure the Main Power Switch is OFF and incoming power is locked OFF. The Hydraulic Unit is a component that works under pressure. Do not open any connection or carry out maintenance on components subject to pressure until all press has been bled to zero.

The hydraulic unit should be serviced **yearly**:

1. Completely drain the Tank of hydraulic fluid.
2. Clean the Tank Top to prevent foreign material from falling into the Tank when the Cover is removed.
3. Unscrew the Suction Pipe from its connection with the Hydraulic Pump.
4. Remove the Cover and Suction Pipe from the Hydraulic Tank. Take care not to damage Tank Cover Gasket.
5. Inspect the bottom of the Tank for sediment and clean as required. Clean the Suction Pipe and its connections
6. Fill the Tank with 12 gal of approved hydraulic fluid. See page 47 for recommendations.
7. Insert the Suction Pipe into the Tank Cover and install the Cover. Again, take care not to damage Tank Cover Gasket. Connect the Suction Pipe securely to the Hydraulic Pump.
8. Ensure the Hydraulic Pump Case is full of fluid and proceed with the normal operation.



# PH-20/PHX-20 Manual

## Metering Pump Line

**WARNING!** Before performing any maintenance, make sure the Main Power Switch is OFF and incoming power is locked OFF. Allow material temperature to cool below 80°F and bleed all material pressure to zero.

**Weekly:** When the Proportioning Pumps are functioning properly it is not unusual to a small amount of Poly (R) material to appear on the Pump Shaft. This material should be wiped away so dirt does not accumulate on the Pump Shaft and the Pump Shaft Packings are not damaged.



**Yearly or as required:** It is not unusually for those who use the PH Series Proportioner on a regular basis to rebuild the Proportioning Pumps on a yearly basis and service the Hydraulic Drive System (page 41) at the same time, when the Proportioner is out of service.

## Pump Seal Replacement

Refer to Parts Identification Drawing (pages 54 (PHX) (56PH) for reference.

### **NOTE!**

- ✓ When Iso (A) Proportioning Pump Cylinder is disassembled for service, all parts included in the Seal Kit (KT-PAX or KT-PA) should be replaced.
- ✓ When the Poly (R) Proportioning Pump Cylinder is disassembled for service, all parts included in the Seal Kit (KT-PAX or KT-PA) should be replaced.
- ✓ When assembling Proportioning Pump lubricate all Seals, Piston Rod and Pump Cylinder with #1 Lithium Grease to assist in assembly and minimize Seal damage during re-assembly.

**CAUTION!** Use wooden or plastic tools or a brass brush for cleaning. Do not use metal or abrasive tools that can scratch the contact surfaces.



# PH-20/PHX-20 Manual

## MAINTENANCE

### Material Heater

**WARNING!** Before performing any maintenance, make sure the Main Power Switch is OFF and incoming power is locked OFF. NEVER access the inside of the Control Panel with the Proportioner power supply ON. The Heaters are components that reach high temperatures; you must wait until they have cooled before handling and bleed all material pressure to zero.



### Thermocouple Replacement

**NOTE!** The Thermocouple is assembled into the Connector Body with a Ferrule and Nut. Once inserted into the Body and the Nut is tightened, the Ferrule locks to the Thermocouple and does not allow it to be relocated or moved. The location of the Thermocouple is very important and must be done correctly before tightening the Nut.

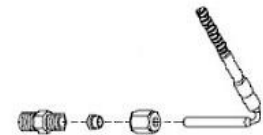

Thermocouple Assembly

1. Unscrew the Nut that holds the defective Thermocouple and remove from the Body. Disconnect Thermocouple wiring located under the Top Cover of the Heater. Remove Body and discard.
2. Install Heating Element and Spring if also removed.
3. Install Connector Body into Heater using an open-end wrench and tighten to prevent leakage. Teflon Tape or appropriate Thread Sealant should be used.
4. Slide the Nut and the Ferrule over the Thermocouple and insert this assembly into the Connector Body until it comes into **positive physical contact** with the Heating Rod. Make sure the Spring does not prevent the Thermocouple from making contact with the Heating Rod.
5. Slowly tighten the Nut using an open-end wrench, ensuring the Thermocouple maintains positive physical contact with the Heating Rod.
6. Reinstall the Thermocouple wires.

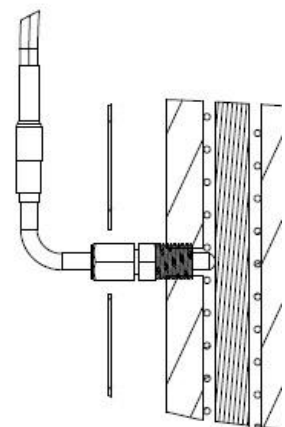

Thermocouple Positive Contact



# PH-20/PHX-20 Manual

## MAINTENANCE

### Material Heater (cont'd)

**WARNING!** Before performing any maintenance, make sure the Main Power Switch is OFF and incoming power is locked OFF. NEVER access the inside of the Control Panel with the Proportioner power supply ON. The Heaters are components that reach high temperatures; you must wait until they have cooled before handling and bleed all material pressure to zero.



### Heating Rod

To replace defect Heating Rod proceed as follows:

1. Ensure Main Power Switch is OFF and incoming power is locked OFF. Depressurize proportioner and, remove the Cover on Heater.

**WARNING!** If the Heating Rod to be replaced is the one in contact with the Thermocouple, it is necessary to remove the Thermocouple first (see page 39). Do not loosen or tighten Thermocouple Body.

2. Disconnect the suspect Heating Rod from the wire connections and test Heating Rod again for proper electrical resistance. 1250 Watt Heating Rod is 37 ohms, 1500 Watt Heating Rod is 31 ohms.
3. Unscrew the Heating Rod and remove from the Heater Block along with its Spring and inspect; it must be smooth and shiny in appearance. If it is blackened or has material adhered to it replace the Heating Rod even if ohm reading is acceptable.
4. Apply Teflon Tape or appropriate Thread Sealant to the Heating Rod thread and assemble Heating Rod and Spring into the Heater Block. Tighten securely to 110 ft/lbs.
5. If necessary carefully re-install Thermocouple ensuring **positive physical contact** with the Heating Rod. Make sure the Spring does not prevent the Thermocouple from making contact with the Heating Rod. Tighten Nut with open-end wrench.
6. Reconnect wire connections and replace Cover.
7. Ensure Heater is full of material prior to electrical testing.



# PH-20/PHX-20 Manual

## **HYDRAULIC OIL SPECIFICATIONS**

Recommended Hydraulic Oil Specification:

ISO/ASTM Viscosity Grade 32

Viscosity: 28.8 – 35.2 SSU@ 104° F

Rust and Oxidation Inhibited

Manufacturers:

|                        |                                   |                                  |
|------------------------|-----------------------------------|----------------------------------|
| Mobil DTE24*           | American Oil & Supply – PQ Iso 32 | Fiske Bros. – Lubriplate Hyd. #0 |
| Cook's Albavis 8       | Gulf Oil – Harmony 32AW (43AW)    | SW – Alemite Hydraulic HD#0      |
| Ashland-Valvoline AW15 | Atlantic Richfield – Duro AWS-150 | Texaco – Rando HD32 (HD A0)      |
| Shell - Tellus 32(25)  | BP Oil – Energol HLP-C32          | White & Bagley – EP Hyd. 150     |
| Sun Oil - Sunvis 706   | Exxon – Nuto H-32(44)             |                                  |
| Chevron ISO32          | A. Margolis – T.I.P.100-15-7      |                                  |

\* Preferred



# PH-20/PHX-20 Manual

## REPLACEMENT KITS

### Hydraulic Cylinder Rebuild Kit

#### KT-05200

| P/N        | Description           | QTY |
|------------|-----------------------|-----|
| HI-05025-1 | U-Cup                 | 2   |
| HI-05025-2 | Back-up Ring, Piston  | 2   |
| HI-05025-3 | Wear Ring             | 1   |
| HI-05025-4 | Rod Wiper             | 2   |
| HI-05025-5 | Shaft Seal            | 2   |
| HI-05025-6 | Back-up Ring, Bushing | 2   |
| OR-00039A  | O-ring                | 2   |
| OR-00040A  | O-ring                | 2   |

### Heater Thermocouple Kit

#### KT-05021

| P/N      | Description        | QTY |
|----------|--------------------|-----|
| HI-05020 | Body, Nut, Ferrule | 1   |
| HI-05021 | Thermocouple       | 1   |

### PUMP REBUILD KITS

| P/N    | Description                                  | QTY |
|--------|--|-----|
| KT-PAX | PHX pump rebuild kit (3000 psi), see page 52 | 1   |
| KT-PA  | PH pump rebuild kit (2000 psi), see page 54  | 1   |





# PH-20/PHX-20 Manual

## HEATER PARTS

| <b>PART NUMBER</b> | <b>DESCRIPTION</b>               | <b>QTY PER HEATER</b> |
|--------------------|----------------------------------|-----------------------|
| PH-16              | COMPLETE "A" SIDE HEATER, PH-20  | 1                     |
| PH-17              | COMPLETE "R" SIDE HEATER, PH-20  | 1                     |
| PH-18              | COMPLETE "A" SIDE HEATER, PHX-20 | 1                     |
| PH-19              | COMPLETE "R" SIDE HEATER, PHX-20 | 1                     |
| GM-06424-1         | HEATER BODY                      | 2                     |
| GM-06424-2         | PHONOLIC WASHER                  | 4                     |
| GM-05423-1250      | HEATER CARTRIDGE, PH-20          | 3                     |
| GM-05423-1500      | HEATER CARTRIDGE, PHX-20         | 3                     |
| GM-05423-7         | SPRING                           | 3                     |
| KT-05020           | THERMOCOUPLE KIT                 | 1                     |
| HI-05034           | O-RING PLUG                      | 3                     |
| EL-00006A          | OVER TEMP SWITCH                 | 1                     |
| HI-05036           | 1/4" PIPE PLUG                   | 2                     |
| HI-05026           | OUTLET HEATER FITTING "R"        | 1                     |
| HI-05027           | OUTLET HEATER FITTING "A"        | 1                     |
| HI-05059           | INLET HEATER FITTING             | 1                     |
| HI-05088           | 1/4"M x 1/4"F, NPT FITTING       | 1                     |
| GP-00100-3         | 1/4" RUNNING TEE                 | 1                     |
| HI-05028           | GAUGE, 0-3000 PSI (PH-20)        | 1                     |
| HI-00035           | GAUGE, 0-5000 PSI (PHX-20)       | 1                     |

## REVERSING SWITCH PARTS

| <b>PART NUMBER</b> | <b>DESCRIPTION</b>            | <b>QTY</b> |
|--------------------|-------------------------------|------------|
| EL-00021           | REVERSING SWITCH              | 1          |
| RM-216             | REVERSING SWITCH BRACKET      | 1          |
| RM-217             | REVERSING SWITCH PLATE        | 1          |
| RM-218             | REVERSING SWITCH COVER, FRONT | 1          |
| RM-219             | REVERSING SWITCH COVER, BACK  | 1          |
| RM-220             | REVERSING SWITCH TRIP ARM     | 1          |
| RM-221             | REVERSING SWITCH TRIP SHAFT   | 1          |

# PH-20/PHX-20 Manual

## MOTOR LINE PARTS

| <b>PART NUMBER</b> | <b>DESCRIPTION</b>                 | <b>QTY</b> |
|--------------------|------------------------------------|------------|
| EL-05224           | ELECTRIC MOTOR, 3HP, 3 PHASE, 60HZ | 1          |
| EL-05221           | ELECTRIC MOTOR, 3HP, 1 PHASE, 60HZ | 1          |
| HI-05001           | BELL HOUSING                       | 1          |
| HI-00065-01        | MAGNALOY INSERT                    | 1          |
| HI-00065-02        | MAGNALOY HUB, 1-1/8 x 1/4          | 1          |
| HI-00065-03        | MAGNALOY HUB, 3/4 x 3/16           | 1          |
| HI-05006           | HYDRAULIC PUMP                     | 1          |
| HI-05004-1         | HYDRAULIC PUMP CONTROL KNOB        | 1          |
| HI-05006-3         | HYDRAULIC PUMP INLET PIPE          | 1          |
| HI-00005-03        | ACCESS COVER                       | 1          |

## HOSE TRANSFORMER PARTS

| <b>PART NUMBER</b> | <b>DESCRIPTION</b>           | <b>QTY</b> |
|--------------------|------------------------------|------------|
| EL-05228           | TRANSFORMER, 72 VOLTS        | 1          |
| EL-150             | BREAKER, 63 AMPS             | 1          |
| EL-00118A-00-1     | BREAKER MOUNT                | 1          |
| EL-05235           | THERMOCOUPLE HARNESS         | 1          |
| EL-05230-01        | CONDUIT, 3/4" FLEX           | 2 FT       |
| EL-05230-02        | CONDUIT CONNECTOR, STRIGHT   | 1          |
| EL-05230-03        | CONDUIT CONNECTOR, 90 DEGREE | 1          |
| RM-00019           | #6 WIRE                      | 2x3 FT     |
| KT-00029A          | HOSE CONNECTOR               | 2          |
| EL-000P7           | STRAIN RELIEF, SMALL         | 1          |
| EL-000P12          | STRAIN RELIEF, LARGE         | 2          |

# PH-20/PHX-20 Manual

## HYDRAULIC TANK PARTS

| <b>PART NUMBER</b> | <b>DESCRIPTION</b> | <b>QTY</b> |
|--------------------|--------------------|------------|
| RM-213             | TANK LID           | 1          |
| HI-00014-04A       | GASKET, TANK TOP   | 1          |
| TN-05704           | CASTERS            | 4          |
| HI-00002-A         | GROMMET, TANK TOP  | 1          |
| HI-05048           | DRAIN PLUG         | 1          |
| RM-212             | TRANSFORMER DOOR   | 1          |

## Y-STRAINER PARTS

| <b>PART NUMBER</b> | <b>DESCRIPTION</b>                   | <b>QTY</b> |
|--------------------|--------------------------------------|------------|
| YS-1               | Y-STRAINER ASSY, A SIDE              | 1          |
| YS-2               | Y-STRAINER ASSY, R SIDE              | 1          |
| RA-00074-00A       | Y-STRAINER (60 MESH)                 | 1          |
| RA-00078A          | BALL VALVE 3/4"                      | 1          |
| HI-05015           | 3/4 NPT ELBOW                        | 1          |
| HI-05016           | 3/4 " x 3/4" SWIVEL FITTING "R" SIDE | 1          |
| HI-05017           | 3/4" HEX NIPPLE                      | 1          |
| HI-05018           | 3/4 " x 1/2" SWIVEL FITTING "A" SIDE | 1          |
| SP-00009A          | REPLACEMENT SPRING                   | 1          |
| RA-00074-02A       | REPLACEMENT GASKET                   | 1          |
| RA-00074-03-80A    | REPLACEMENT SCREEN, 80 MESH          | 1          |
| RA-00074-03-60A    | REPLACEMENT SCREEN, 60 MESH          | 1          |
| RA-00074-03-30A    | REPLACEMENT SCREEN, 30 MESH          | 1          |

## PRESSURE GAUGES

| <b>PART NUMBER</b> | <b>DESCRIPTION</b>                   | <b>QTY</b> |
|--------------------|--------------------------------------|------------|
| HI-00035           | PHX PRESSURE GAUGE, FLUID 0-5000 PSI | 2          |
| HI-05028           | PH PRESSURE GAUGE, FLUID 0-3000 PSI  | 2          |
| HI-05040-2         | PRESSURE GAUGE, HYDRAULIC 0-2000PSI  | 1          |

## HEATED HOSES and REPLACEMENTS

# PH-20/PHX-20 Manual

| <b>PART NUMBER</b> | <b>DESCRIPTION</b>                              | <b>QTY</b> |
|--------------------|---|------------|
| MA-00014A          | 3/8 x 50' LOW PRESSURE HOSE,2250 psi            | 1          |
| MA-00014-TC        | 3/8 x 50' LOW PRESSURE HOSE,2250 psi W/TC WIRE  | 1          |
| MA-00040A          | 1/4 x 10" GUN HOSE ASSY W/SCUFF JACKET 3500psi  | 1          |
| MA-00039A          | 3/8 x 50' HIGH PRESSURE HOSE,3500 psi           | 1          |
| MA-00039A-TC       | 3/8 x 50' HIGH PRESSURE HOSE,3500 psi W/TC WIRE | 1          |
| MA-00014A-TC-35    | 3/8 x 35' LOW PRESSURE HOSE,2250 psi W/TC WIRE  | 1          |
| MA-00039A-TC-35    | 3/8 x 35' HIGH PRESSURE HOSE,3500 psi W/TC WIRE | 1          |
| MA-00014A-A-50     | 3/8 x 50' "A" SIDE LOW PRESSURE HOSE,2250 psi   | 1          |
| MA-00014A-R-50     | 3/8 x 50' "R" SIDE LOW PRESSURE HOSE,2250 psi   | 1          |
| MA-00040A-A        | 1/4 x 10" "A" SIDE GUN HOSE, 3500psi            | 1          |
| MA-00040A-R        | 1/4 x 10" "R" SIDE GUN HOSE, 3500psi            | 1          |
| MA-00005A-50       | 50' SCUFF JACKET                                | 1          |
| MA-00005A-35       | 35' SCUFF JACKET                                | 1          |
| MA-00005A-10       | 10' SCUFF JACKET                                | 1          |

## **HYDRAULIC/MACHINE HOSES**

|            |   |   |
|------------|---|---|
| HI-05047-1 | HOSE, FLUID PUMP TO HEATER 16.5"              | 2 |
| HI-05047-2 | HOSE, HYDRAULIC PUMP TO TANK 9"               | 1 |
| HI-05047-3 | HOSE, BOTTOM HYDRAULIC CYL. TO MANIFOLD 17.5" | 1 |
| HI-05047-4 | HOSE, TOP HYDRAULIC CYL. TO MANIFOLD 13"      | 1 |
| HI-05013   | HOSE, HYDRAULIC PUMP OUTLET 24"               | 1 |

## **HOSE TEMPERATURE SENSING UNIT (TSU)**

| <b>PART NUMBER</b> | <b>DESCRIPTION</b>                   | <b>QTY</b> |
|--------------------|--------------------------------------|------------|
| EL-51A             | TSU ASSEMBLY                         | 1          |
| EL-51A-2           | TSU PROBE REPLACEMENT                | 1          |
| EL-00051A-1        | TSU BODY                             | 1          |
| EL-00051A-3        | FITTING, 1/8 NPT x #4 JIC SWIVEL     | 1          |
| EL-00051A-4        | FITTING, 1/4 NPT x #5 JIC MALE (A)   | 1          |
| EL-00051A-5        | FITTING, 1/4 NPT x #6 JIC SWIVEL (R) | 1          |
| EL-00051A-6        | FITTING, 1/4 NPT x #6 JIC (R)        | 1          |
| EL-00051A-7        | FITTING, 1/4 NPT x #5 JIC SWIVEL (A) | 1          |
| EL-00051A-8        | INSULATION                           | 1          |

## **HI-02 HYDRAULIC MANIFOLD ASSEMBLY**

# PH-20/PHX-20 Manual

| <i><b>PART NUMBER</b></i> | <i><b>DESCRIPTION</b></i>      | <i><b>QTY</b></i> |
|---------------------------|--------------------------------|-------------------|
| HI-05070-1                | MANIFOLD, HYDRAULIC            | 1                 |
| HI-05070-2                | DRAIN TUBE ¼"                  | 1                 |
| HI-05040-2                | GAUGE, 0-2000 psi Bottom mount | 1                 |
| HI-05003                  | DIRECTIONAL VALVE              | 1                 |
| GP-00100-5                | ELBOW                          | 1                 |
| HI-05038                  | FITTING,                       | 1                 |

## HI-05200 HYDRAULIC CYLINDER

| <i><b>PART NUMBER</b></i> | <i><b>DESCRIPTION</b></i> | <i><b>QTY</b></i> |
|---------------------------|---------------------------|-------------------|
| HI-05200-1                | PISTON                    | 1                 |
| HI-05200-2                | CYLINDER                  | 1                 |
| HI-05200-3                | PORT BLOCK                | 2                 |
| HI-05200-5                | Bolt, TIE ROD             | 4                 |
| HI-05201                  | MOUNTING PLATE            | 1                 |
| HI-05202                  | MOUNTING PLATE, PUMP YOKE | 1                 |
| HI-002                    | NUT, YOKE                 | 1                 |
| HI-05025-1*               | U CUP                     | 2                 |
| HI-05025-2*               | RING, BACK UP             | 2                 |
| HI-05025-3*               | RING, WEAR                | 1                 |
| HI-05025-4*               | ROD WIPER                 | 2                 |
| HI-05025-5*               | SEAL, SHAFT               | 2                 |
| HI-05025-6*               | RING, BACK UP             | 2                 |
| OR-00039A*                | O-RING                    | 2                 |
| OR-00040A*                | O-RING                    | 2                 |

NOTE: \* Included in Hydraulic Rebuild Kit KT-05025

# PH-20/PHX-20 Manual

## A/R PUMP 3000 PSI – PHX-20 SIZE 61

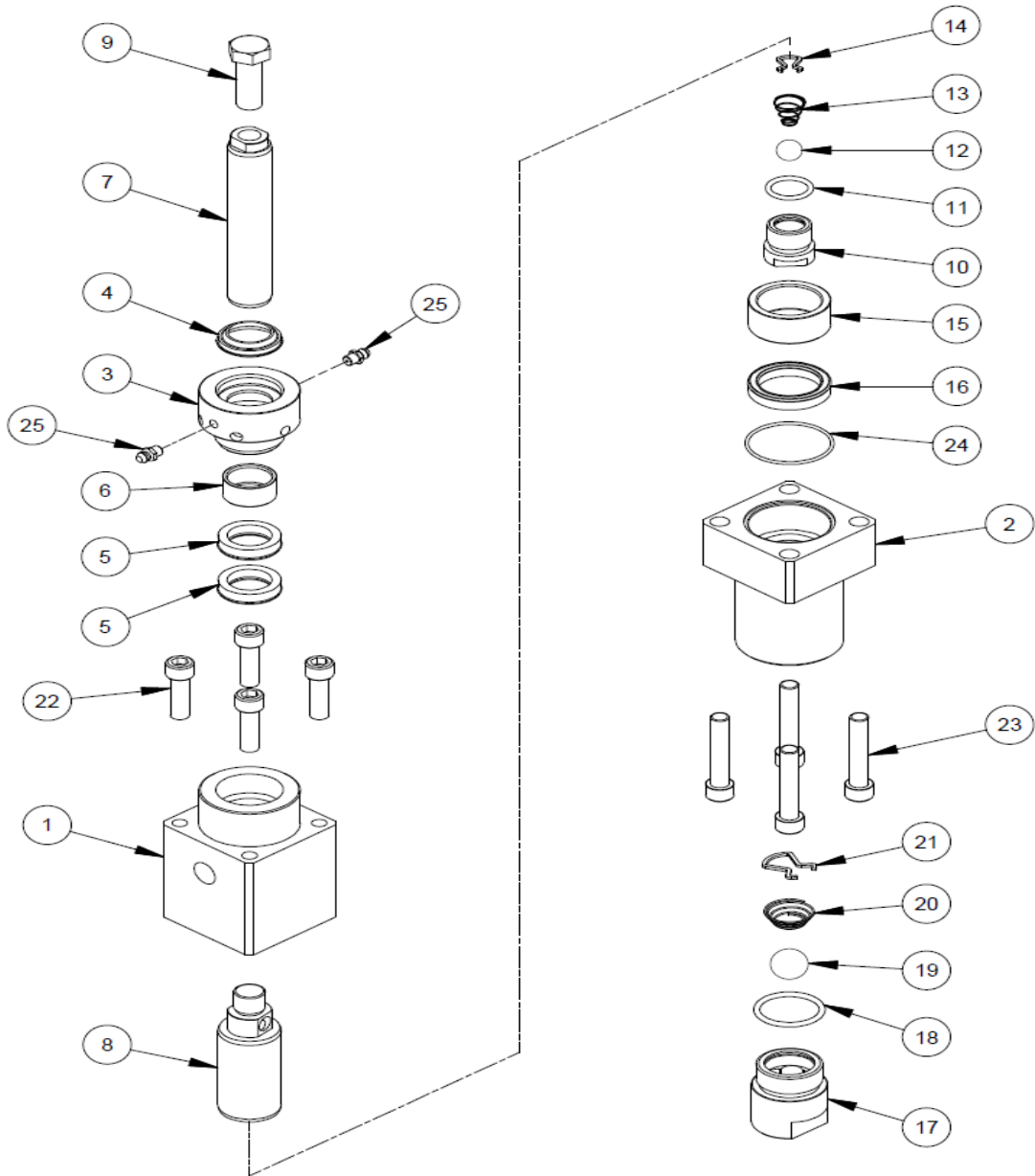

# PH-20/PHX-20 Manual

## A/R PUMP 3000 PSI - PHX-20 SIZE 61 PUMP PARTS LIST

| ITEM | PART NUMBER | QTY | DESCRIPTION            |
|------|-------------|-----|------------------------|
| 1    | PAX-045     | 1   | OUTLET BODY            |
| 2    | PAX-053     | 1   | INLET BODY             |
| 3    | PAX-064     | 1   | PACKING NUT/GREASE CUP |
| 4*   | PAX-065     | 1   | SCRAPER SEAL           |
| 5*   | PAX-052     | 2   | ROD SEAL ASSEMBLY      |
| 6    | PAX-051     | 1   | ROD BUSHING            |
| 7    | PAX-062     | 1   | FLUID ROD              |
| 8    | PAX-047     | 1   | PISTON                 |
| 9    | PA-063      | 1   | BOLT                   |
| 10   | PAX-046     | 1   | PISTON VALVE           |
| 11*  | OR-116      | 1   | O-RING                 |
| 12   | PAX-059     | 1   | BALL ½"                |
| 13   | PAX-049     | 1   | SPRING                 |
| 14   | PAX-050     | 1   | SPRING RETAINER        |
| 15   | PAX-055     | 1   | PISTON BUSHING         |
| 16*  | PAX-052     | 1   | ROD SEAL ASSEMBLY      |
| 17   | PAX-058     | 1   | INLET VALVE            |
| 18*  | OR-916      | 1   | O-RING                 |
| 19   | PA-048      | 1   | BALL ¾"                |
| 20   | PAX-061     | 1   | SPRING, FOOT VALVE     |
| 21   | PA-050      | 1   | SPRING RETAINER        |
| 22   | PA-056      | 4   | CAP SCREW              |
| 23   | PA-057      | 4   | CAP SCREW              |
| 24*  | OR-030      | 1   | O-RING                 |
| 25   | PA-066      | 2   | GREASE FITTING         |

PACKING KIT PART NUMBER

KT-PAX

\*ASTERISKS DENOTES PARTS INCLUDED IN THE SEAL KIT

# PH-20/PHX-20 Manual

## A/R PUMP 2000 PSI – PH-20 SIZE 123

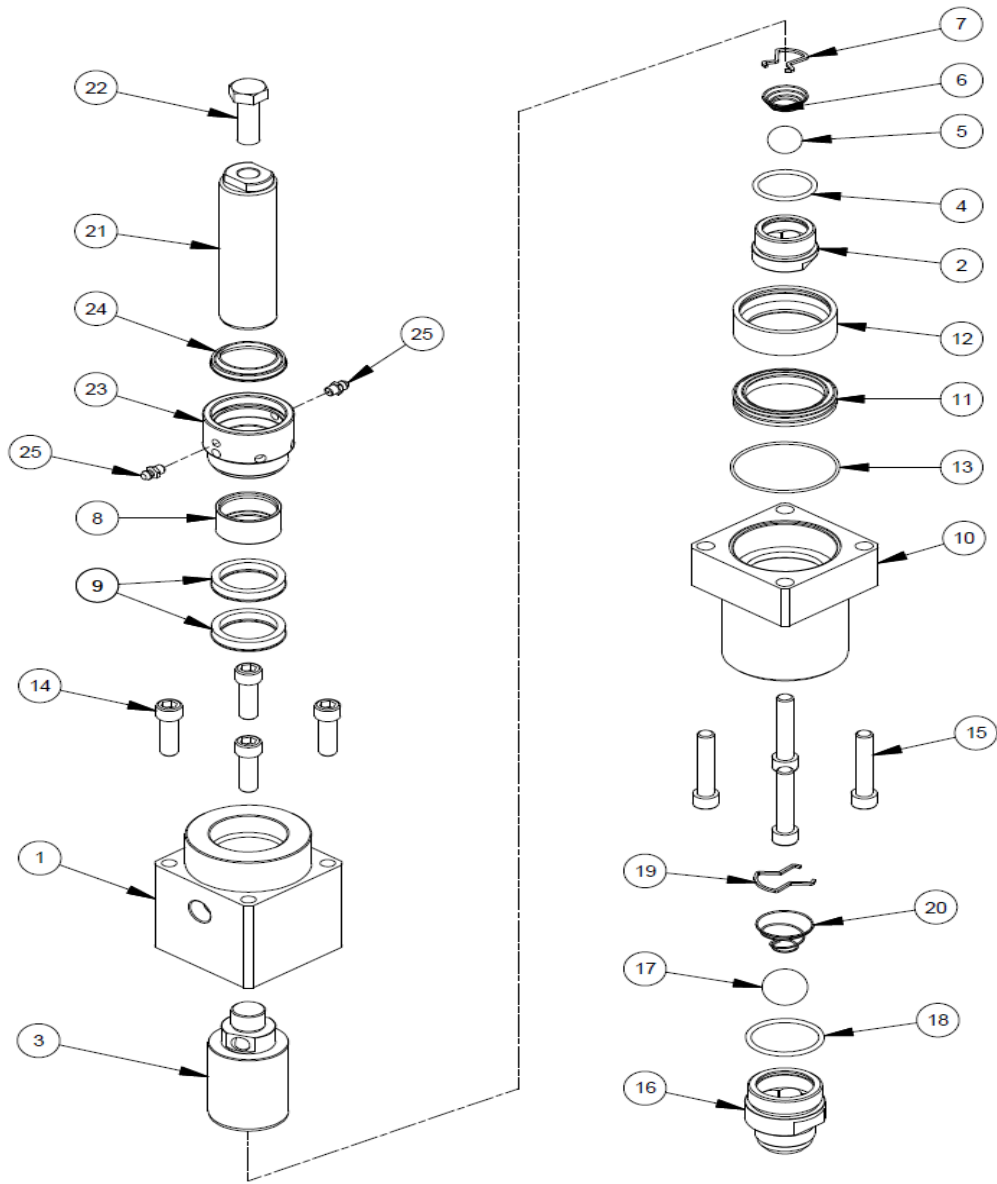



# PH-20/PHX-20 Manual

## A/R PUMP 2000 PSI - PH-20 SIZE 123 PUMP PARTS LIST

| ITEM | PART NUMBER | QTY | DESCRIPTION            |
|------|-------------|-----|------------------------|
| 1    | PA-045      | 1   | OUTLET BODY            |
| 2    | PA-046      | 1   | PISTON VALVE           |
| 3    | PA-047      | 1   | PISTON                 |
| 4*   | OR-916      | 1   | O-RING                 |
| 5    | PA-048      | 1   | BALL, 3/4"             |
| 6    | PA-049      | 1   | SPRING                 |
| 7    | PA-050      | 1   | SPRING RETAINER        |
| 8    | PA-051      | 1   | ROD BUSHING            |
| 9*   | PA-052      | 2   | ROD SEAL ASSEMBLY      |
| 10   | PA-053      | 1   | INLET BODY             |
| 11*  | PA-054      | 1   | PISTON SEAL ASSEMBLY   |
| 12   | PA-055      | 1   | PISTON BUSHING         |
| 13*  | OR-035      | 1   | O-RING                 |
| 14   | PA-056      | 4   | CAP SCREW              |
| 15   | PA-057      | 4   | CAP SCREW              |
| 16   | PA-058      | 1   | INLET VALVE            |
| 17   | PA-059      | 1   | BALL, 1"               |
| 18 * | OR-920      | 1   | O-RING                 |
| 19   | PA-060      | 1   | BALL STOP              |
| 20   | PA-061      | 1   | FOOT VALVE SPRING      |
| 21   | PA-062      | 1   | FLUID ROD              |
| 22   | PA-063      | 1   | BOLT                   |
| 23   | PA-064      | 1   | PACKING NUT/GREASE CUP |
| 24 * | PA-065      | 1   | SCRAPER SEAL           |
| 25   | PA-066      | 2   | GREASE FITTING         |

PACKING KIT PART NUMBER

KT-PA

\*ASTERISKS DENOTES PARTS INCLUDED IN THE SEAL KIT

# PH-20/PHX-20 Manual

## CONSOLE BOTTOM ELECTRICAL PARTS

| <b>Part No.</b> | <b>Description</b>             | <b>Quantity</b> |
|-----------------|--------------------------------|-----------------|
| EL-116          | HEATER BREAKER, 25 AMP         | 2               |
| EL-117          | HOSE BREAKER, 20 AMP           | 1               |
| EL-114          | CONTROL BREAKER, 3 AMP         | 1               |
| EL-110          | MOTOR BREAKER, 32 AMP/1 PHASE  | 1               |
| EL-162          | MOTOR BREAKER, 20 AMP/3 PHASE  | 1               |
| EL-122          | POWER SUPPLY, DC               | 1               |
| EL-120          | RELAY, DPDT (CONTACTOR)        | 1               |
| EL-119          | CONTACTOR, 25 AMP              | 1               |
| EL-118          | MOTOR CONTACTOR                | 1               |
| EL-161          | MOTOR OVERLOAD, 3 PHASE ONLY   | 1               |
| EL-34           | RELAY, SSR 50 AMP (A/R HEATER) | 2               |
| EL-35           | RELAY, SSR 95 AMP (HOSE)       | 1               |

# PH-20/PHX-20 Manual

## **CONSOLE PANEL ELECTRICAL PARTS**

| <b>Part No.</b> | <b>Description</b>            | <b>Quantity</b> |
|-----------------|-------------------------------|-----------------|
| EL-124          | TOTALIZER                     | 1               |
| EL-127          | AUTO COUNT DOWN               | 1               |
| EL- T1          | TEMPERTURE CONTROLLER, HOSE   | 1               |
| EL- T2          | TEMPERTURE CONTROLLER, HEATER | 2               |

## **EMERGENCY STOP SWITCH**

| <b>Part No.</b> | <b>Description</b>      | <b>Quantity</b> |
|-----------------|-------------------------|-----------------|
| EL-133-NO       | SWITCH, NORMALLY OPEN   | 1               |
| EL-107          | E-STOP KNOB             | 1               |
| EL-131-R        | LIGHT                   | 1               |
| EL-133-NC       | SWITCH, NORMALLY CLOSED | 1               |

## **HOSE (1) / HEATER (2) SWITCH**

| <b>Part No.</b> | <b>Description</b>    | <b>Quantity</b> |
|-----------------|-----------------------|-----------------|
| EL-133-NO       | SWITCH, NORMALLY OPEN | 1               |
| EL-131-R        | LIGHT                 | 1               |

## **MAIN POWER LIGHT ASSEMBLY**

| <b>Part No.</b> | <b>Description</b> | <b>Quantity</b> |
|-----------------|--------------------|-----------------|
| EL-134          | SOCKET             | 1               |
| EL-132-G        | LIGHT              | 1               |
| EL-135          | LENS               | 1               |

## **MAIN POWER SWITCH**

| <b>Part No.</b> | <b>Description</b> | <b>Quantity</b> |
|-----------------|--------------------|-----------------|
| EL-103          | MOUNTING KIT       | 1               |
| EL-100          | DISCONNECT         | 1               |
| EL-105          | HANDLE             | 1               |

# PH-20/PHX-20 Manual

## CONTROL POWER SWITCH

| Part No.  | Description             | Quantity |
|-----------|-------------------------|----------|
| EL-18-R   | KNOB ASSY               | 1        |
| EL-130    | INSERT, MOMENTARY       | 2        |
| EL-133-NC | SWITCH, NORMALLY CLOSED | 1        |
| EL-133-NO | SWITCH, NORMALLY OPEN   | 1        |

## MOTOR SWITCH

| Part No.  | Description           | Quantity |
|-----------|-----------------------|----------|
| EL-129-R  | KNOB ASSY             | 1        |
| EL-131-R  | LIGHT                 | 1        |
| EL-133-NO | SWITCH, NORMALLY OPEN | 1        |

## PUMP SWITCH

| Part No.  | Description           | Quantity |
|-----------|-----------------------|----------|
| EL-128-W  | KNOB ASSY             | 1        |
| EL-133-NO | SWITCH, NORMALLY OPEN | 2        |

## AUTO COUNT DOWN SWITCH

| Part No.  | Description             | Quantity |
|-----------|-------------------------|----------|
| EL-129-G  | KNOB ASSY               | 1        |
| EL-131-G  | LIGHT                   | 1        |
| EL-133-NO | SWITCH, NORMALLY OPEN   | 1        |
| EL-133-NC | SWITCH, NORMALLY CLOSED | 1        |

## RIGHT DIRECTIONAL LIGHT

| Part No. | Description | Quantity |
|----------|-------------|----------|
| EL-134   | SOCKET      | 1        |
| EL-131-W | BULB        | 1        |
| EL-138   | LENS        | 1        |

# PH-20/PHX-20 Manual

## LEFT DIRECTIONAL LIGHT

| <b>Part No.</b> | <b>Description</b> | <b>Quantity</b> |
|-----------------|--------------------|-----------------|
| EL-134          | SOCKET             | 1               |
| EL-131-W        | BULB               | 1               |
| EL-138          | LENS               | 1               |

## TRANSFORMER

| <b>Part No.</b> | <b>Description</b> | <b>Quantity</b> |
|-----------------|--------------------|-----------------|
| EL-150          | BREAKER, 63 AMP    | 1               |

# PH-20/PHX-20 Manual

220 Volt, 1 Phase

PH\_20\_1PH\_P1  
p 1 of 2

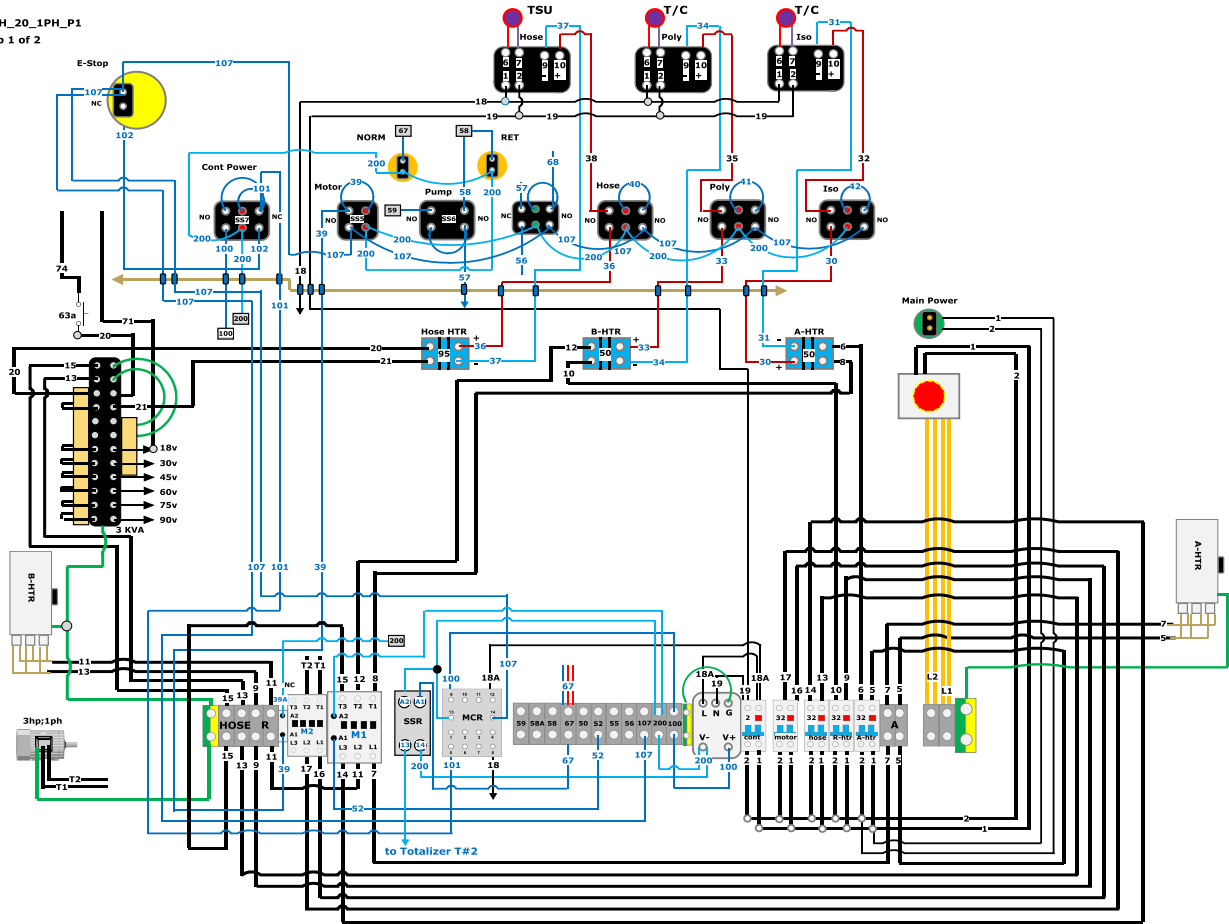



# PH-20/PHX-20 Manual

220 Volt, 1 Phase

PH\_20\_1ph\_p1L

P1 OF 3

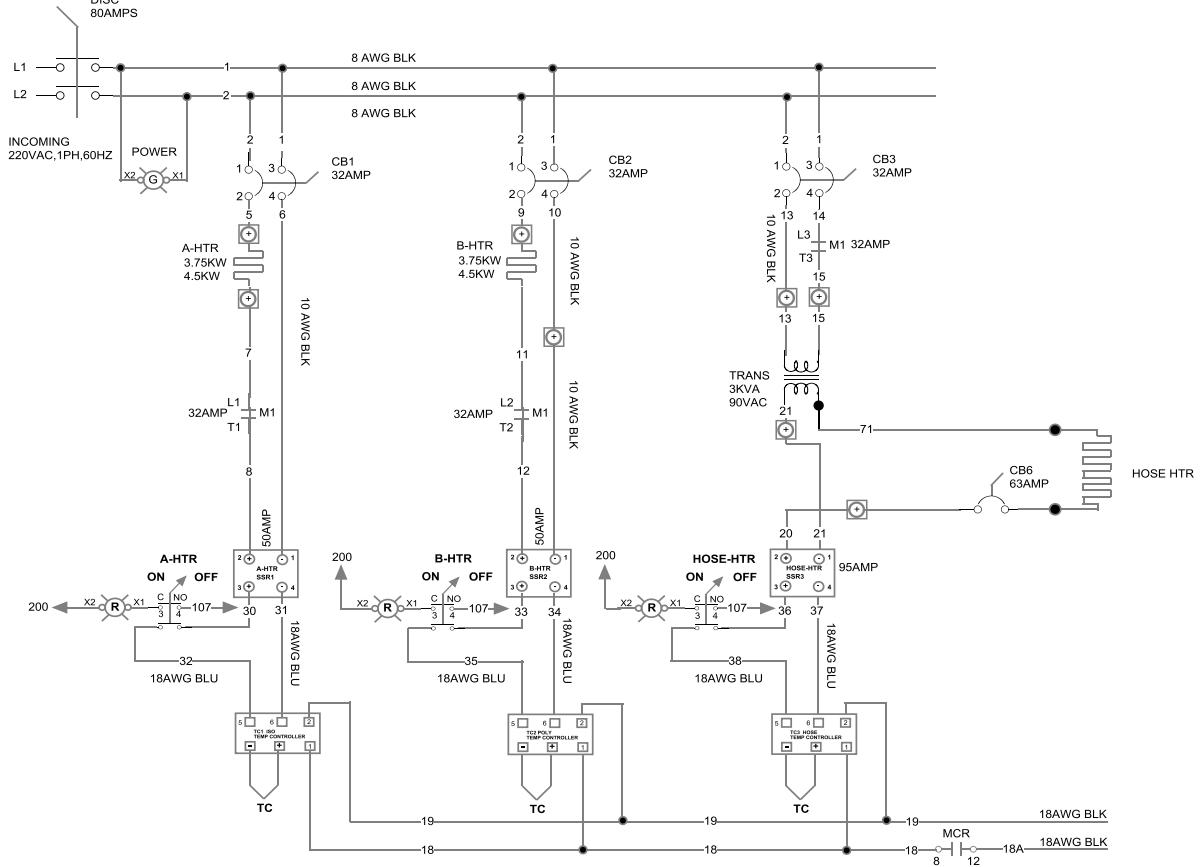



# PH-20/PHX-20 Manual

220 Volt, 1 Phase

PH\_20\_1ph\_p2L  
P2 OF 3

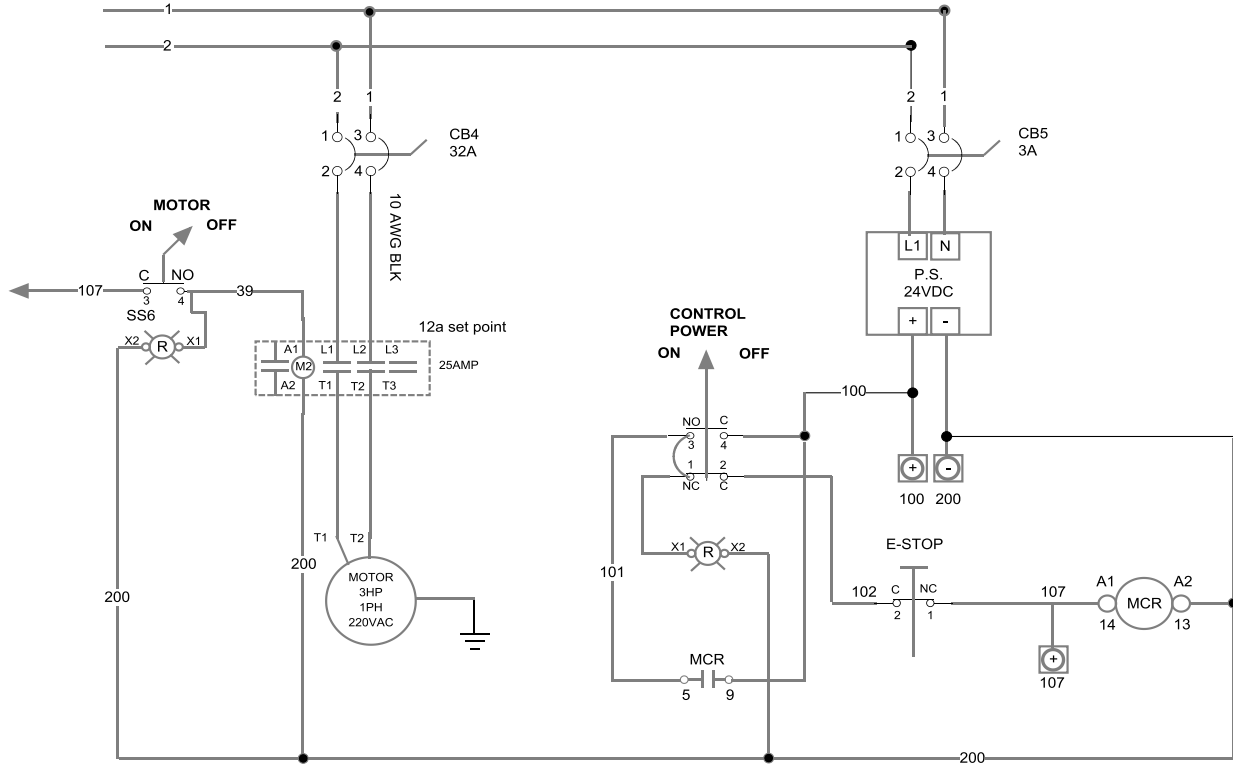

# PH-20/PHX-20 Manual

220 Volt, 1 Phase

PH\_20\_1ph\_p3L  
P3 OF 3

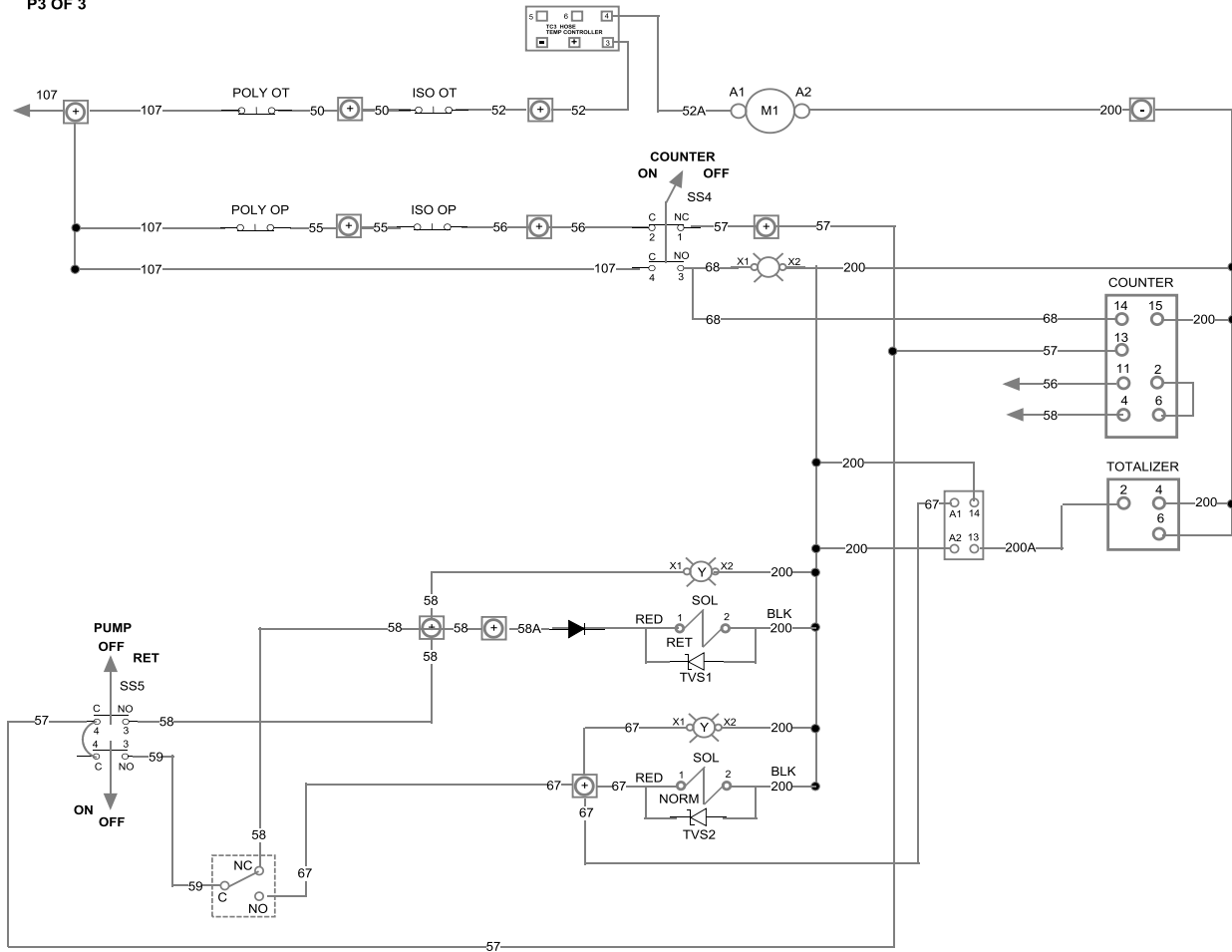





# PH-20/PHX-20 Manual

220 Volt, 3 Phase

PH\_20\_3ph\_p1L  
P1 OF 3

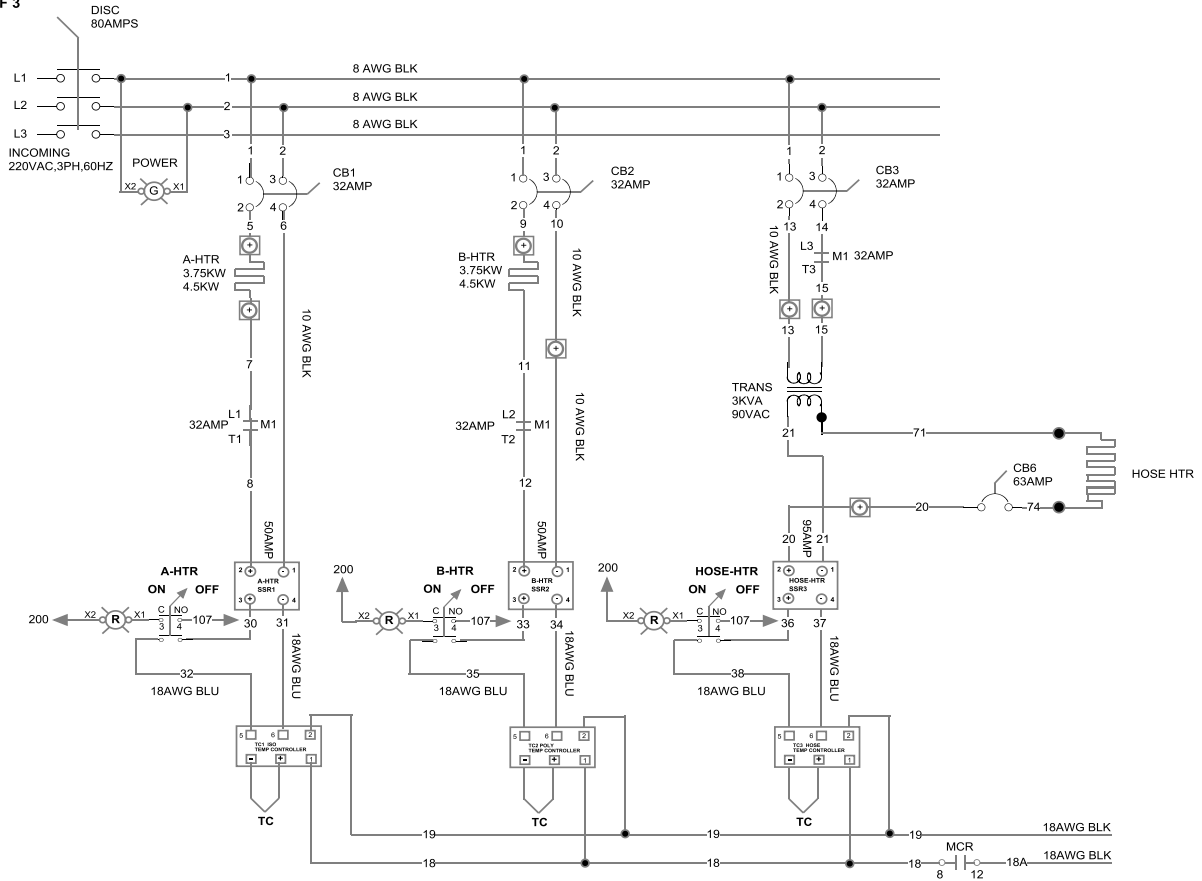



# PH-20/PHX-20 Manual

220 Volt, 3 Phase

PH\_20\_3ph\_p3L  
P3 OF 3

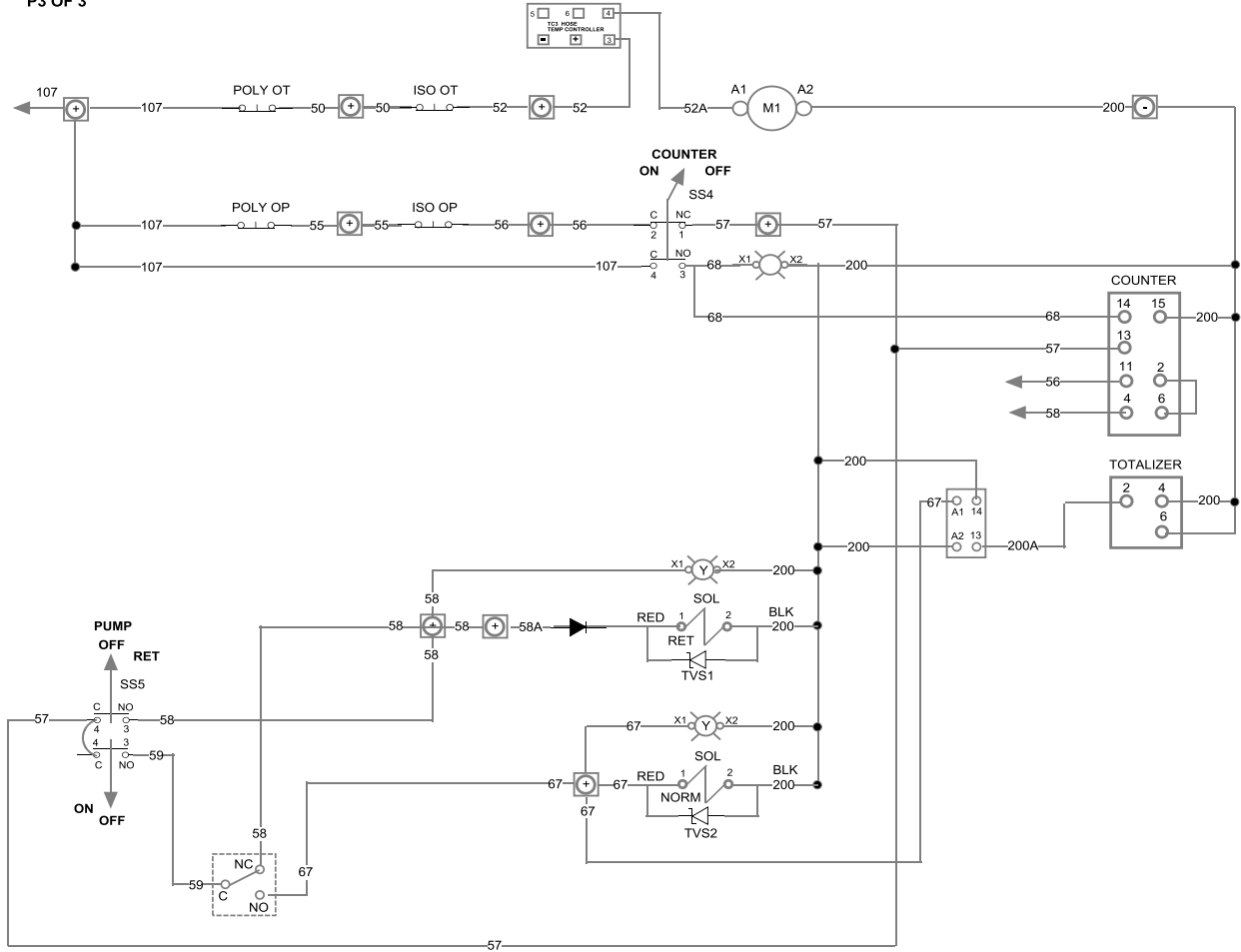

# PH-20/PHX-20 Manual

380 Volt, 3 Phase

pmc\_3x380\_p1

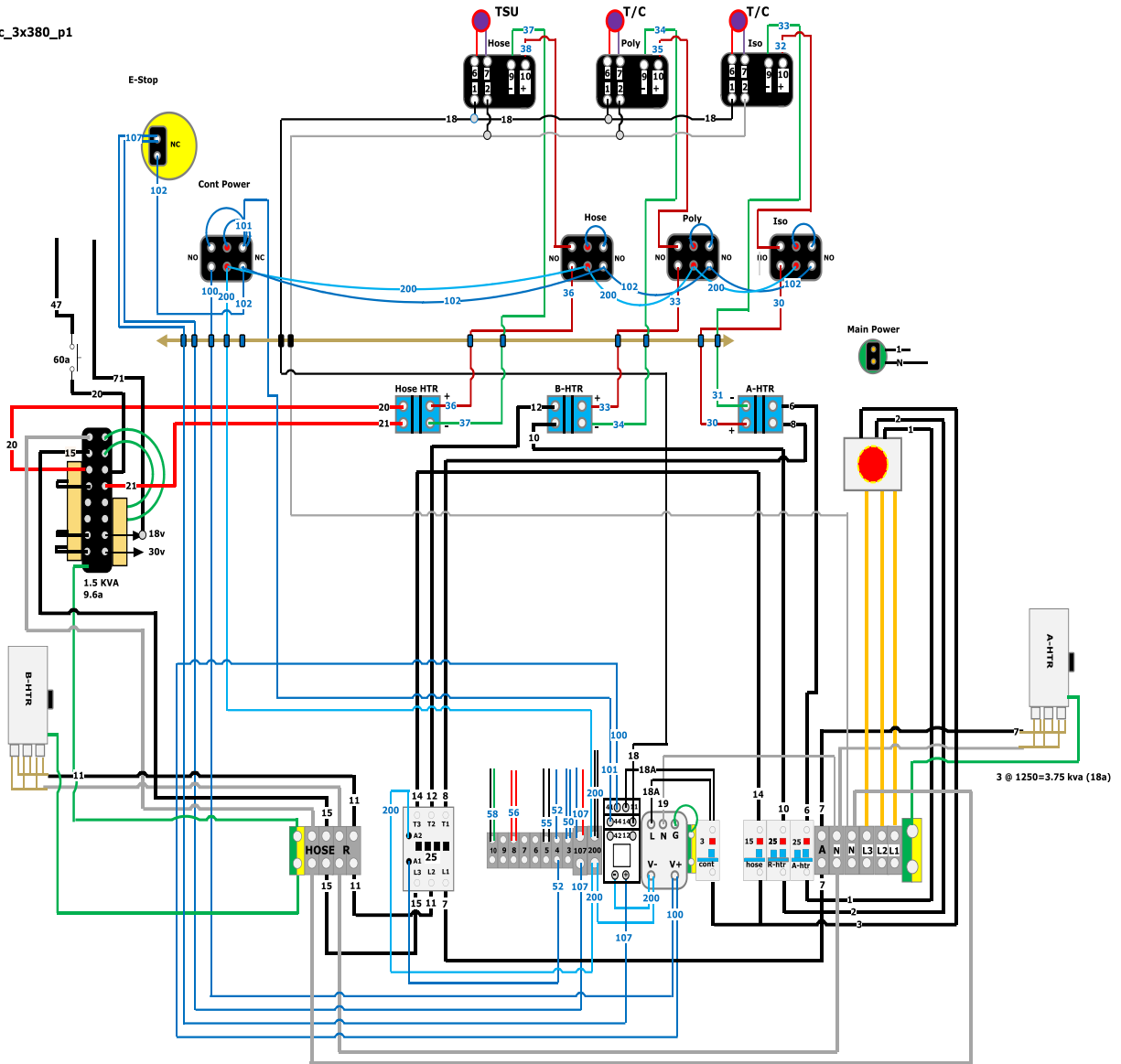



# PH-20/PHX-20 Manual

380 Volt, 3 Phase

