

Children's Toy ATV

BATTERY POWERED RIDE-ON

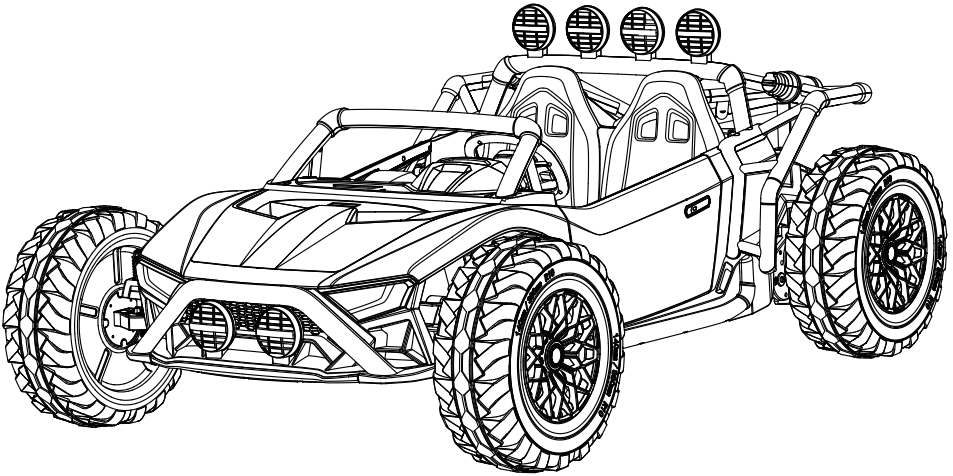

Owner's Manual with Assembly Instructions

Styles and colo(u)rs may vary.
Made in China.

The owner's manual contains important safety information as well as assembly, use and maintenance instructions.

The Ride-on Car must be assembled by an adult who has read and understands the instructions in this manual.

Keep the package away from children and dispose of properly before use.

Keep this manual for future reference.

On the purchase of your new Ride-On.

This ride-on will provide your child with many miles of riding of enjoyment. To help assure you and your rider a safe ride we ask you to please read this manual carefully, and keep it for future reference.

Follow the recommendations in this manual, they are designed to improve the safety and operation of your ride-on car and it's rider.

SPECIFICATIONS:

Battery	12V12AH*1	24V7AH*1
Charger	12V1000mA	24V1000mA

Suitable age:	37-96 months
Load Capacity:	Under 50kg
Speed:	3-6 km/h
Size of car:	148 x 106 x 64 CM
Power way:	Charging type
Charge time:	8-12 hours

 **WARNING!**

- **ADULT ASSEMBLY REQUIRED.**
- **CHOKING HAZARD** - Small parts. Not suitable for children under 36 months. The product contains small parts, keep children away when assembling.
- To reduce the risk of injury, adult supervision is required. Never use in roadways, near motor vehicles, on or near steep inclines or steps, swimming pools or other bodies of water, always wear shoes, and never allow more than 2 rider.
- Always remove protective material and poly bags and dispose before assembly.
- Protective equipment should be worn. Always wear shoes and sit in the seat when operating the vehicle.
- Never leave a child unattended.
- Keep your hands, hair, and clothes away from moving parts.
- Use only battery(ies) and charger specified by the manufacturer
- The battery is not replaceable.

 **SAFETY**

The following safety hazards may result in serious injury or death:

- Never leave child unattended. Direct adult supervision is required. Always keep child in view when child is in vehicle.
- Never use in unsafe conditions such as snow, rain, loose dirt, mud, sand, or gravel, otherwise may result in an unexpected accident such as tipping over, and could damage the electrical system or battery.
- Only drive on level ground. Never use on the lawn.
- Not to be used in traffic.
- This toy should be used with caution since skill is required to avoid falls or collisions causing injury to the user or third parties.
- This toy is unsuitable for children under 36 months due to its maximum speed; Maximum user weight is 50kg.
- This toy has no brake.

 **BATTERY INFORMATION**

- Non-rechargeable batteries are not to be recharged.
- Rechargeable batteries are to be removed from the toy before being charged.
- Rechargeable batteries are only to be charged under adult supervision.
- Different types of batteries or new and used batteries are not to be mixed.
- Batteries are to be inserted with the correct polarity.
- Exhausted batteries are to be removed from the toy.
- The supply terminals are not to be short-circuited.

Parts Diagram | 3

HINT: Some parts shown are assembled on both sides of vehicle

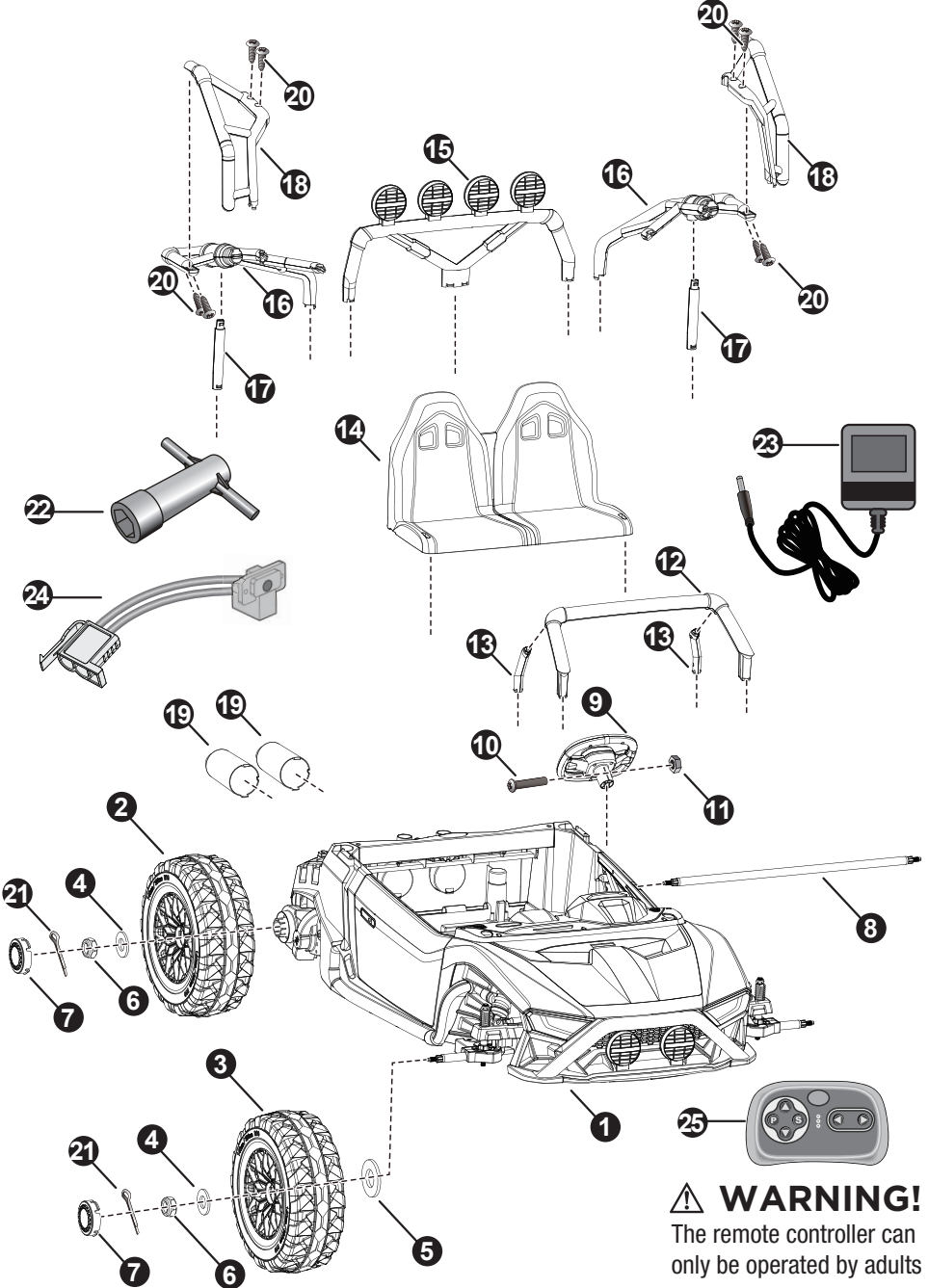

⚠ WARNING!
The remote controller can only be operated by adults

Parts List | 4

PART NO.	PART NAME	Q'TY (PCS)	REMARKS
1	Vehicle body	1	
2	Driving wheel	2	
3	Front wheel	2	
4	Ø12 washer	4	2 pcs on the front axle, 2 pcs on the rear axle,
5	Ø19 washer	2	Placed on the front axle
6	Lock nut	4	2 pcs on the front axle, 2 pcs on the rear axle
7	Hubcap	4	Placed in the assembly package
8	Rear axle	1	
9	Steering wheel	1	
10	M5x30 machine screw	1	Placed on the steering wheel
11	Ø5 nut	1	Placed on the steering wheel
12	Windshield	1	
13	Windshield support	2	Left and right, marked "L" & "R"
14	Seat	1	
15	Light bar	1	
16	Roll cage	2	Left and right, marked "L" & "R"
17	Roll cage support	2	Left and right, marked "L" & "R"
18	Side roll bar	2	Left and right, marked "L" & "R"
19	Rear exhaust	2	
20	Ø4x12 screw	8	Placed in the assembly package
21	Spin split	4	Placed in the assembly package
22	Spanner	2	Placed in the assembly package
23	Charger	1	
24	Charging cable	1	
25	Remote controller	1	Only for the R/C type

Assembly tools required (not included):

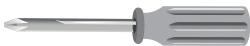

Screwdriver

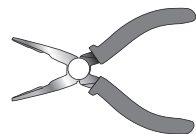

Long nose pliers

Front Bottom View

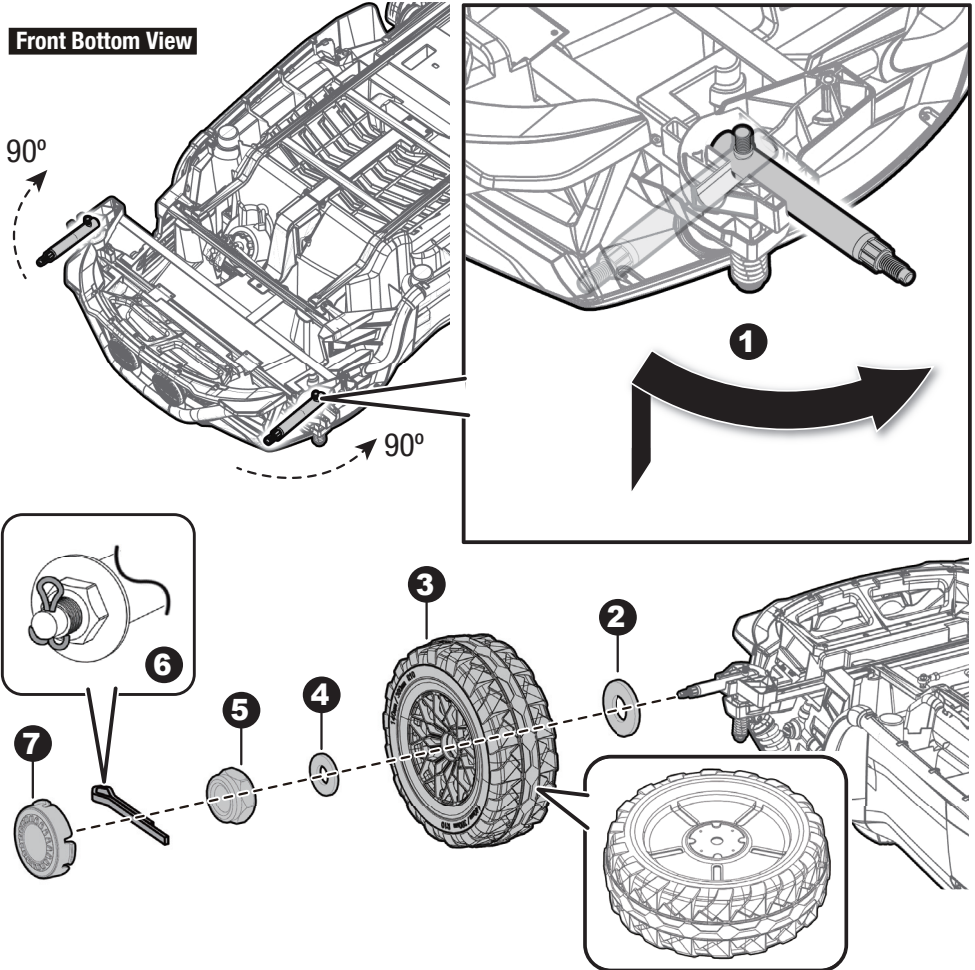

- Remove washers and nuts from the front wheel axle. Turn the vehicle body upside down (this should be handled carefully by two adults).
 - 1. Adjust the front wheel axle until the axle clicks into position to ensure that it is secure for safety.
 - 2. Slide a **Ø19 washer** onto the front axle.
 - 3. Slide a front wheel onto the front axle.
 - 4. Slide a **Ø12 washer** onto the front axle.
 - 5. Tighten a lock nut to the end of the front axle with a spanner. **DO NOT** over tighten.
 - 6. Insert a split pin into the hole on the end of the front axle. Bend the ends of split pin back using a long nose pliers (not included).
 - 7. “Snap” the hubcap to the wheel.
- Repeat the above procedure to assemble the other front wheel.

Attach the Rear Wheels | 6

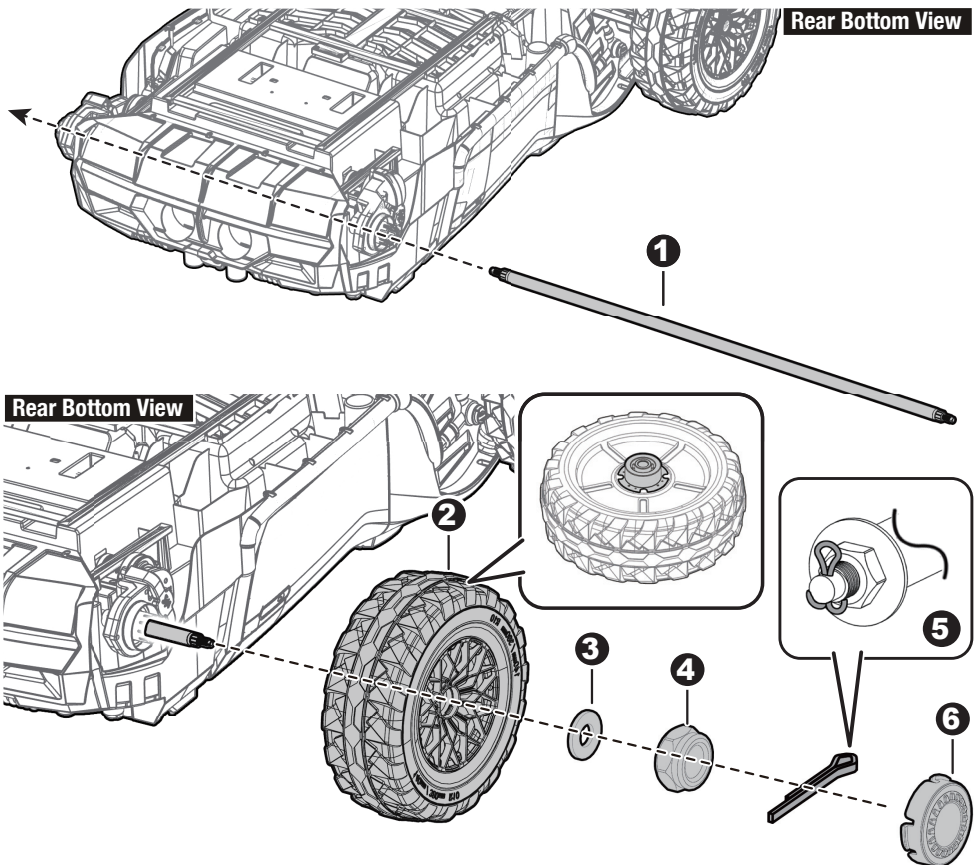

- Cut off the plastic ties on the gear boxes. Remove all the parts from the rear axle.
1. Pass the rear axle through the hole in the gear box, the holes in the body and the hole in the gear box on the other side of the body.
 2. Slide the driving wheel onto the rear axle, ensure the driver on the wheel match up with the gear box.
 3. Slide a $\varnothing 12$ washer onto the rear axle.
 4. Tighten a lock nut to the end of the rear axle with a spanner.
- Repeat the above procedure to assemble the other rear wheel. **HINT:** An extra spanner has been provided to hold the Lock Nut on the other side of the rear axle while tightening the Lock Nut on the other side. **DO NOT** over tighten.
5. Insert the split pin into the hole on each end of the rear axle. Bend the ends of split pins back using a long nose pliers (not included).
 6. “Snap” the hubcaps to the wheels.

Attach the Steering Wheel | 7

HINT: Refer to the battery information on page 2. Batteries Not Included.

1. With a screwdriver loosen the screw on the battery cover located in the center of the steering wheel.
2. Remove the battery cover from the top of the battery compartment.
3. Insert 2x1.5 AA batteries in their correct polarities.
4. Place the battery cover over the battery compartment and fasten with the screw you removed in step one.

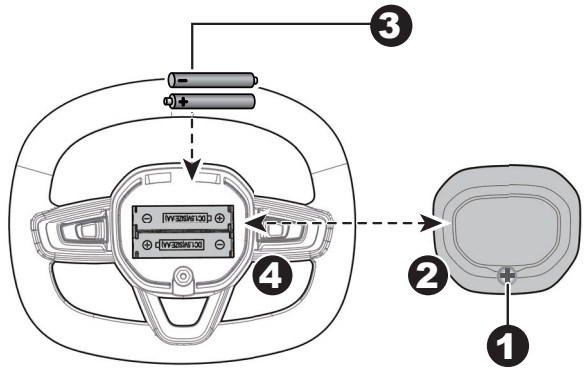

Remove the M5x30 machine screw and $\varnothing 5$ nut from the steering wheel. Turn the vehicle body upright.

5. Place the steering wheel over the the steering column, protruding from the middle of the steering wheel base.
6. Align the holes on each side of steering wheel with the holes at the end of the steering column. Reinsert the M5x30 machine screw.
7. Fasten a nut on the opposite end of the screw to secure the steering wheel to the steering column.

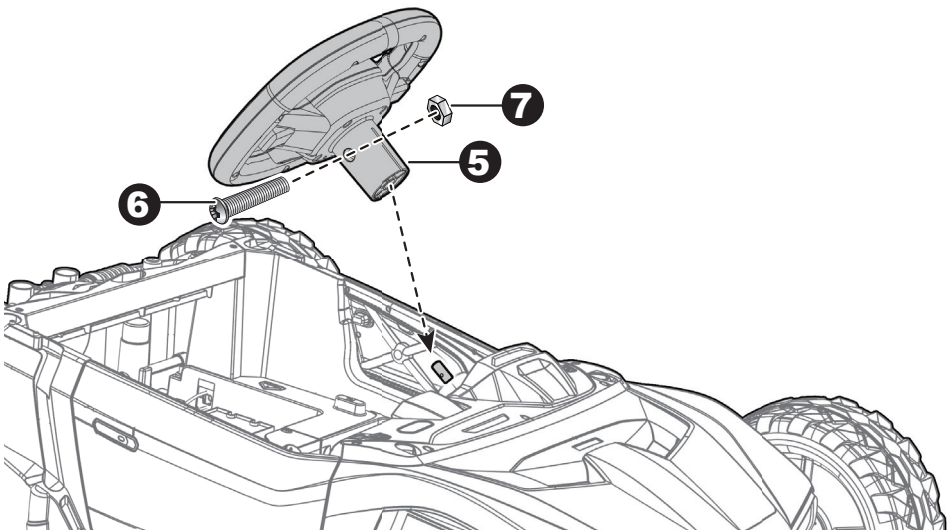

Attach the Windshield & Roll Cage | 8

1. Fit the windshield supports (Marked "L" and "R") to holes in the rear of the windshield, push them until "click" into place.

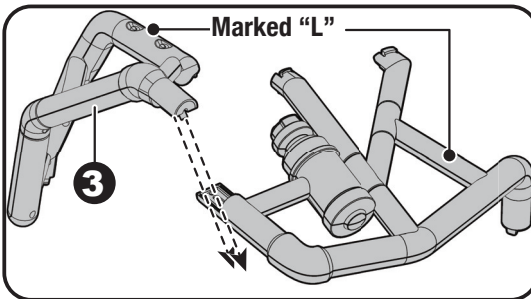
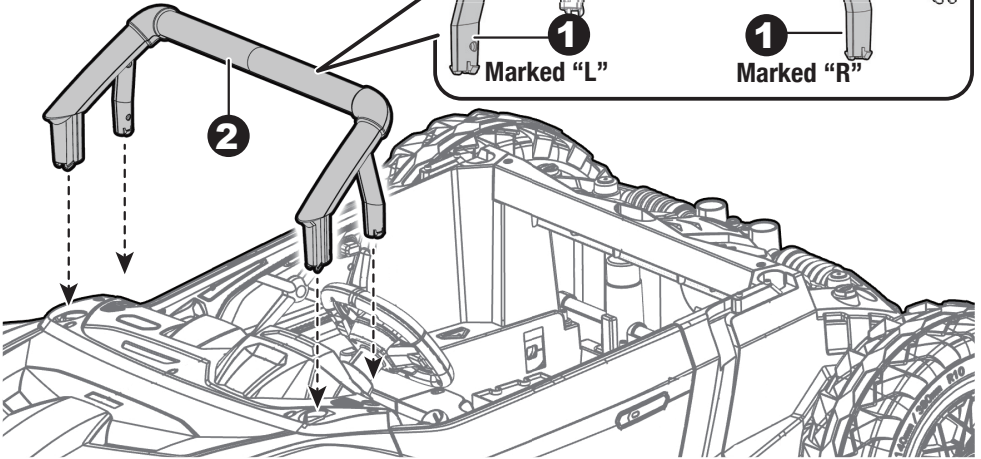
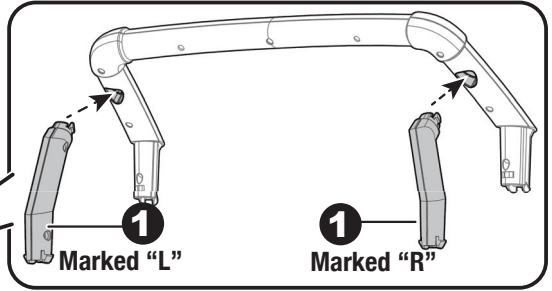

2. Fit the windshield assembly to holes in the body, push until you hear it "click" into place.

- 3-4. Fit the side roll bar (marked "L") to the roll cage (marked "L"), insert and tighten two $\text{\O}4 \times 12$ screws with a screwdriver.

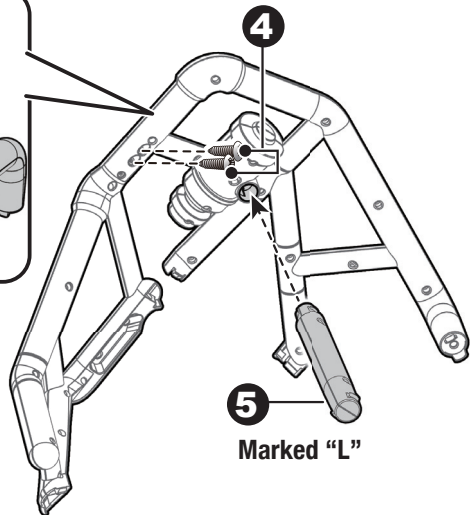

5. Fit the roll cage support into the hole on the bottom of the roll cage.

Repeat steps 3-5 to assemble the other side of the roll cage (marked "R"), side roll bar (marked "R") and roll cage support (marked "R") together.

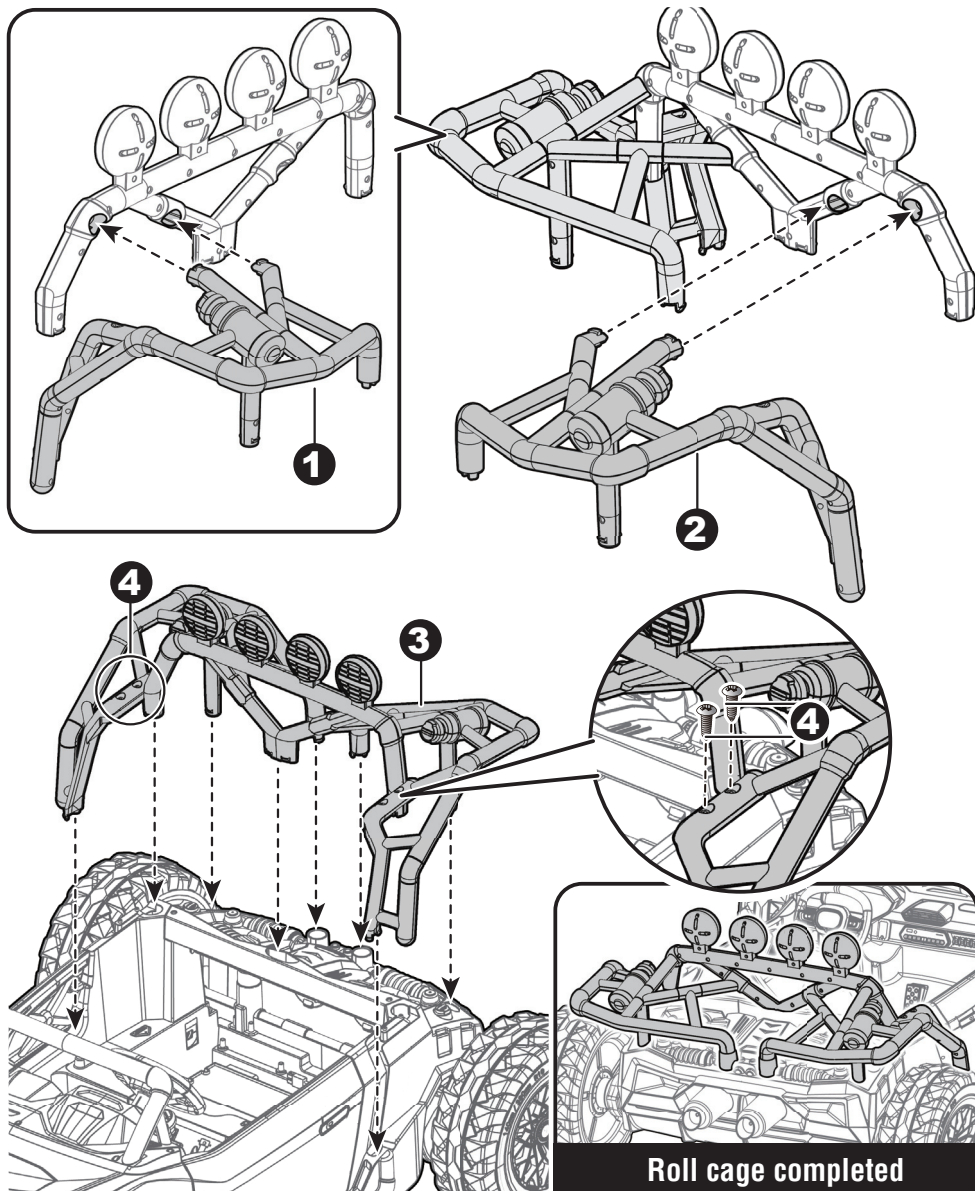

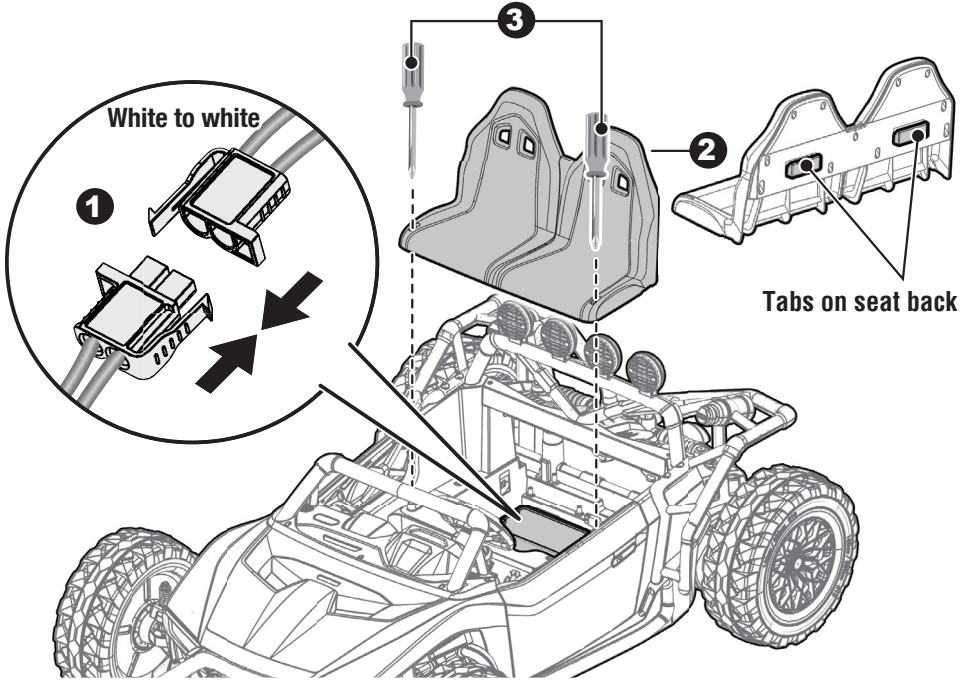

1. Plug the **white connector** on the battery into the **white connector** from the charging port.
2. Fit the tabs on the backrest into the slots in the seat.
3. Tighten the two screws on the top of the seat with a screwdriver.
4. Insert the rear exhausts into the holes on the rear side of the body. Note that the stopper grooves on the exhausts should match up with the stopper points on the body.

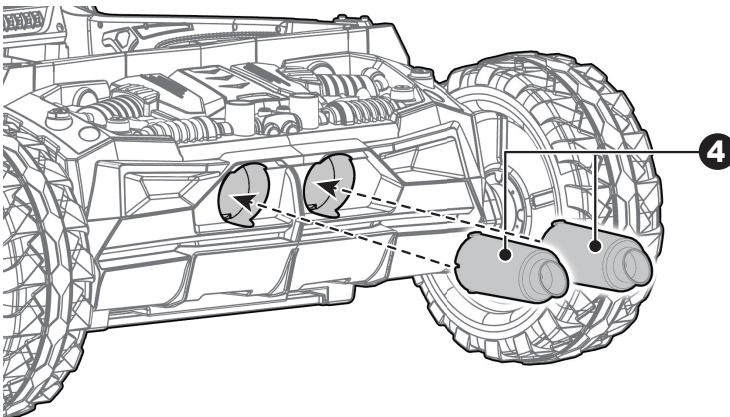

⚠ IMPORTANT

- Always stop vehicle when changing the speed (if equipped) or direction to avoid damage the gears and motor.

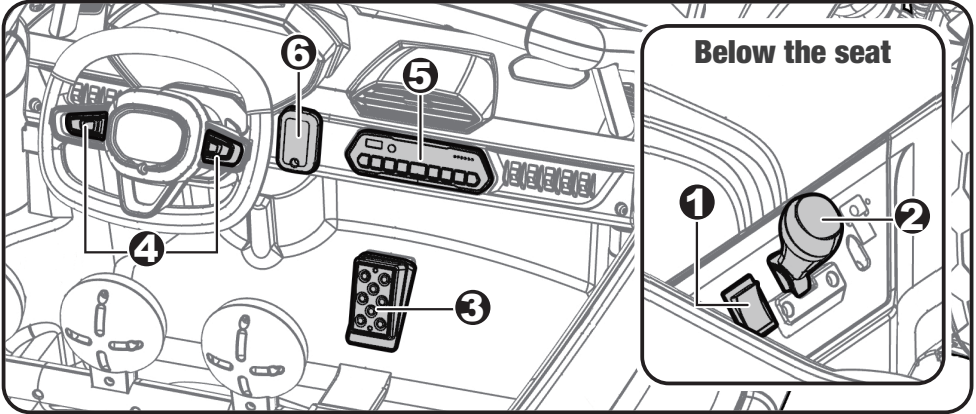

- 1. Power switch (below the seat):** Turns the product on and off.
- 2. Low speed forward/reverse shifter (below the seat):** Changes the direction that vehicle moves from forward to reverse.
 - To move the product forward, shift the lever to top position.
 - To move the product backward, shift the lever to down position.

Refer to the next page to use the high-speed forward function.

- 3. Foot pedal:** Applies power (speed) to the vehicle.
 - To move the car, press the pedal down.
 - To brake or slow down, release pressure from the pedal.
- 4. Sound buttons:** Press for sound playing.
- 5. Audio player**
- 6. R/C-pedal switch:** *Refer to the next page to use the R/C function.*

⚠ IMPORTANT

- The High Speed Protective cover and R/C Protective cover must be removed by an adult. Also those two switches are only allowed to be operated by an adult.
- Keep the protective covers and screws for future use)

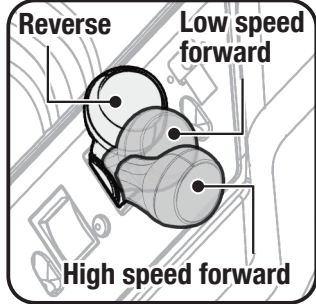
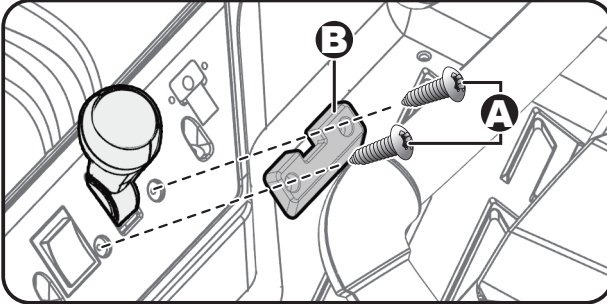

A. Remove the two screws on the top of the high speed protective cover with a screwdriver.

B. Remove the high speed protective cover.

Now you can use the high-speed function of this product

HINT: The product is designed to operate in low speed only in reverse.

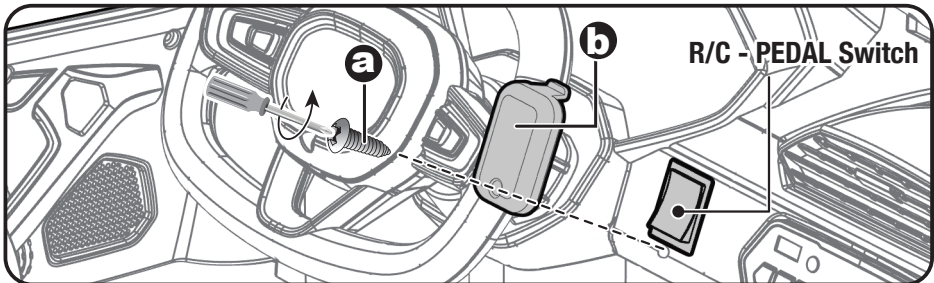

a. Remove the screw on the top of the protective cover with a screwdriver.

b. Remove the protective cover.

After build the connection with the remote controller, you can use the remote control function of this product.

R/C - PEDAL Switch:

Press the switch into the “R/C” position, the turning and movement of the product will be controlled by the remote controller. Press the switch into the “PEDAL” position to turn off the remote control function. Product steering will be controlled by the steering wheel and movement by the **foot pedal**.

⚠ WARNING!

- **ONLY an adult is allowed charge and recharge the battery!**
- **This product with Charging Protection: when charging, all functions will be cut off.**

- The POWER SWITCH must be turned in OFF position when charging.
- Before the first use, you should charge the battery for 4-6 hours. Do not recharge the battery for more than 10 hours to avoid overheating the charger.
- When the vehicle begins to run slowly, recharge the battery.
- After each use or once a month minimum recharge time as 8 to 12 hours, less than 20 hours at most.
- Use only battery(ies) and charger specified by the manufacturer. Using another battery or charger may cause a fire or explosion. Do not use the battery or charger for any other product.
- If your ride-on with a Digital voltmeter(IF EQUIPPED), the magnitude of voltage will tell you how much power is remaining in the battery when you must recharge the battery. Make sure the vehicle is stop!

12V product	less than 12.5v	The battery needs to be charge.
24V product	less than 24v	

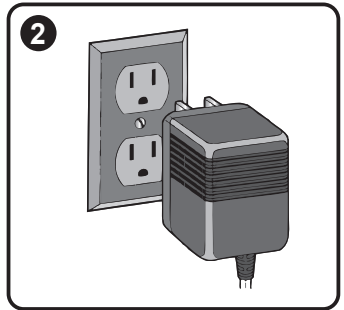
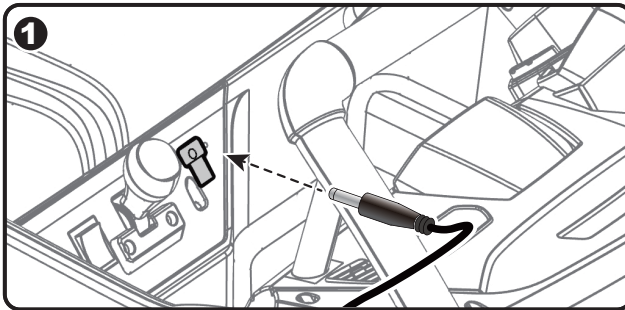
Charging Way I

1. Plug the charger port into the input socket (the socket is below the seat).
2. Plug the charger plug into a wall outlet. The battery will begin charging.

Battery Disposal

The battery will eventually lose the ability to hold a charge. Depending on the amount of use, and varying conditions, the battery should operate for one to three years. Important! Recycle the dead battery responsibly. The battery contains lead acid (electrolyte) and must be disposed of properly and legally. It is illegal in most areas to incinerate lead acid batteries or dispose of them in landfills. Take it to a federal or state-approved lead acid battery recycler, such as local automotive battery retailer. Do not throw the battery away with your regular household waste!

Charging Way II

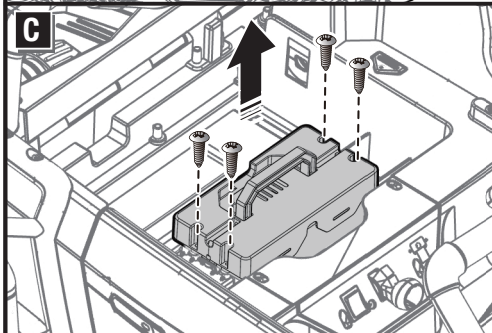
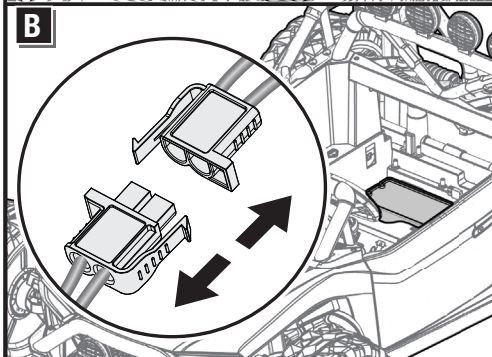
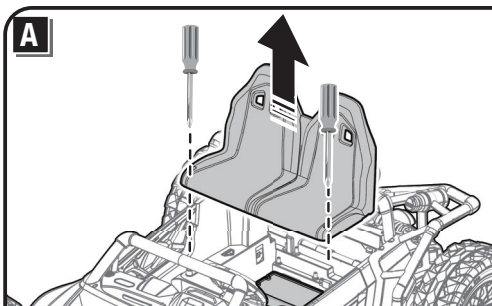

A: Use a screwdriver to loosen the two screws on the top of the seat and remove the seat.

B: Unplug the white connectors from each other.

C. Loosen the four screws around the battery cover with a screwdriver and lift the battery up.

D. Place the battery on a flat ground. Insert the **white connector** from the charging cable into the **white connector** on the battery.

E. Plug the charger port into the charging input socket from the charging cable.

F. Plug the charger plug into a wall outlet. The battery will begin charging.

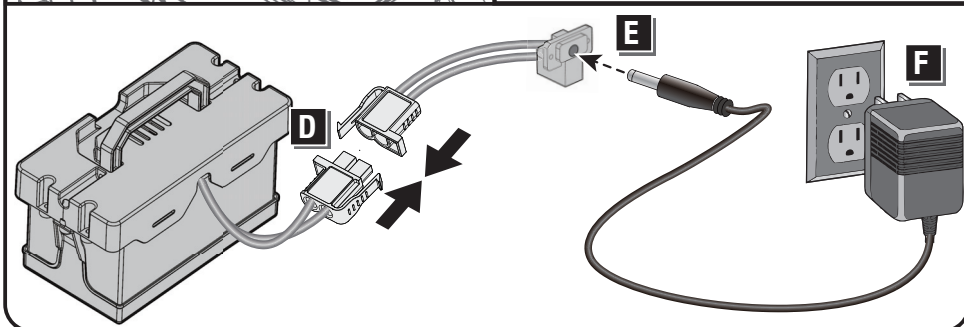

- It is parents' responsibility to check main parts of the toy before using, Must regularly examine for potential hazard, such as the battery, charge, cable or cord, plug, screws are fastening enclosure of other parts and that in the event of such damage, the toy must not be used until that damage had been properly removed.
- Park the vehicle indoors or cover it with a tarp to protect it from wet weather.
- Recharge the battery after each use. Only an adult can handle the battery. Recharge the battery at least once a month when the vehicle raider is not being used.
- Do not wash the vehicle with a hose. Do not wash the vehicle with soap and water. Do not drive the vehicle in rainy or snowy weather. Water will damage the motor, electric system and battery.
- Clean the vehicle with a soft, dry cloth. To restore shine to plastic parts, use a non-wax furniture polish. Do not use car wax. Do not use abrasive cleaners.
- When not using, all the electrical source should be turn off. Turn off the power switch and disconnect the battery connection.

Fuse

The battery features a thermal fuse with a reset fuse that will automatically trip and cut all power to the vehicle if the motor, electric system or battery is overloaded. The fuse will reset and power will be restored after the unit is turned OFF for 20 seconds and then turned ON again. If the thermal fuse trips repeatedly during normal use, the vehicle may need repair. Contact your distributor please.

To avoid losing power, follow these guidelines:

- Do not overload the vehicle.
- Do not tow anything behind the vehicle.
- Do not drive up steep slopes.
- Do not drive into fixed objects, which may cause the wheels to spin, causing the motor to overheat.
- Do not drive in very hot weather, components may overheat.
- Do not allow water or other liquids to come in contact with the battery or other electric components.
- Do not tamper with the electric system. Doing so may create a short, causing the fuse to trip.

Problem	Possible Cause	Solution
Vehicle does not run	Battery low on power	Recharge battery.
	Thermal fuse has tripped	Reset fuse, see <Fuse>
	Battery connector or wires are loose	Check that the battery connectors are firmly plugged into each other. If wires are loose around the motor contact your distributor please.
	Battery is dead	Replace battery, contact your distributor please.
	Electrical system is damaged	Contact your distributor please.
	Motor is damaged	Contact your distributor please.
Vehicle does not run very long	Battery is under charged	Check that the battery connectors are firmly plugged into each other when recharging
	Battery is old	Replace battery, contact your distributor please.
Vehicle runs sluggishly	Battery low on power	Recharge battery, contact your distributor please.
	Battery is old	Replace battery, contact your distributor please.
	Vehicle is overload	Reduce weight on vehicle.
	Vehicle is being used in harsh conditions	Avoid using vehicle in harsh conditions, see <Safety>.
Vehicle needs a push to go forward	Poor contact of wires or connectors	Check that the battery connectors are firmly plugged into each other. If wires are loose around the motor, contact your distributor please.
	“Dead Spot” on motor	A dead spot means the electric power is not being delivered to the terminal connection and the vehicle needs repair. Contact your distributor please.
Difficult shifting from forward to reverse or vice-versa	Attempting to shift while the vehicle is motion	Completely stop the vehicle and shift, see <Use Your Ride-On>
Loud grinding or clicking noises coming from motor or gear box	Motor or gears are damaged	Contact your distributor please.
Battery will not recharge	Battery connector or adapter connector is loose	Check that the battery connectors are firmly plugged into each other.
	Charger not plugged in	Check that the battery charger is plugged into a working wall outlet.
	Charger is not working	Contact your distributor please.
Charger feels warm when recharging	This is normal and not a cause for concern	

Completely read through this manual and the troubleshooting guide table before calling. If you still need help resolving the problem **Contact your distributor please.**

**Our products are suitable for
ASTM F963; GB6675; EN71 and EN62115 standard.**

