



LIVE AIR 3 SMART

(PDL-AFX-RA-SP)

Welcome To Use LIVE AIR 3 SMART



Bluetooth Controller
(PDL-TC-AFX)

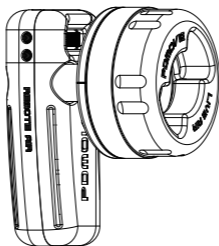

Large handwheel device
(REMOTE AIR RIG)

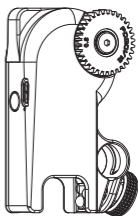

Motor Smart
(PD-BTMP-SP)

Notice For Use

- Before using the product, please read the instructions carefully or watch the tutorial videos to learn how to use the products properly. If there are any direct or indirect adverse effects due to operational errors, PDMOVIE will not assume any responsibility. (Instructional Video: <https://www.pdmovie.com/pages/live-air-3-smart-instructions>)
- Please do not dismantle, repair or refit the internal structure of the product without authorization. If the product is damaged due to the above improper operation, PDMOVIE has the right to refuse product service.
- If you need technical support or if the product has any problems, please contact us.

E-mail: pd@pdmovie.com

Website: www.pdmovie.com

Instagram: [pdmovie_official](https://www.instagram.com/pdmovie_official)

Facebook: PDMovie

Youtube: PDMOVIE

WhatsApp: +8613542105054

Product List



①

Bluetooth Controller
(PDL-TC-AFX)



②

Large Handwheel Device
(REMOTE AIR RIG)



③

Motor Smart
(PD-BTMP-SP)



④

Hot Shoe Clamp



⑤

Fixed Fixture



⑥

LIR2477 Battery



⑦

LI-42Bx3 Battery



⑧

Battery Charger



⑨

Rod Adapter



⑩

10CM&5CM Rod



⑪

Lens Gear Ring



⑫

**Type-C & Micro USB
Charging Cable**

Number	Name	PDL-AFX-RA-SP
1	Bluetooth Controller (PDL-TC-AFX)	1
2	Large Handwheel Device (REMOTE AIR RIG)	1
3	Motor Smart (PD-BTMP-SP)	1
4	Hot Shoe Clamp	1
5	Fixed Fixture	1
6	LIR2477 Battery	2
7	LI-42Bx3 Battery	2
8	Battery Charger	1
9	Rod Adapter	1
10	10CM&5CM Rod (DIA15mm)	1
11	Lens Gear Ring	1
12	Type-C & Micro USB Charging Cable	2

Instructions for Use

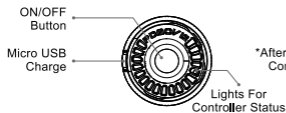
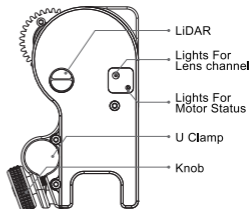
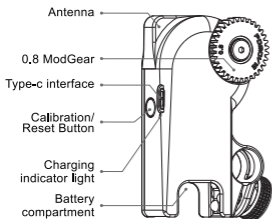

*After Removing the Controller Shell

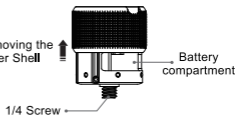

1. Install Motor

Install the motor on the rod and make sure the motor gear matches with the lens gear. Install the motor on the rod and make sure the motor gear matches with the lens gear. (If it install on DSLR Camera lens, please use the camera hot shoe clamp to mount the clamp on hot shoe of the camera or the camera cage 1/4 screw hole)

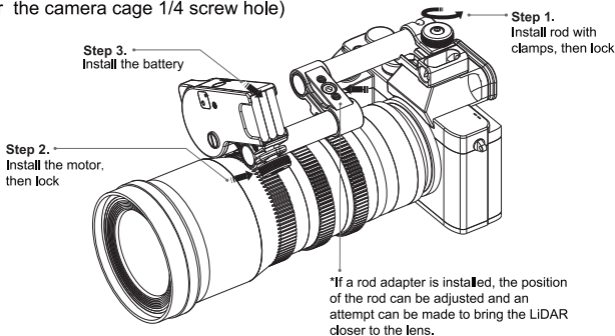



1. When installing, it is recommended to place the LiDAR as close to the lens axis as possible for optimal results



2. The installation position of the LiDAR can be chosen based on the emphasis of the composition of the scene



3. The field of view of the LiDAR is 28 degrees, so when using it, be careful not to obstruct it

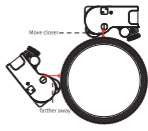

4. When the front end of the lens is wide, the position of the LiDAR should be adjusted appropriately to avoid obstruction

***Autofocus is compatible with most manual lenses that have a focus hard stop or depth of field scale, such as DSLR electronic lenses with a depth of field scale. Lenses without a focus hard stop and depth of field scale are not compatible.**

***If using lenses without a 0.8 mod focus gear, an additional focus gear ring needs to be installed. The motor gear needs to be meshed tightly with the focus gear ring, then the motor can normally drive the lens.**

2. Turn On The Bluetooth Controller And Motor

*Press the ON/OFF button on the Bluetooth controller for three seconds until the indicator light turns on.

*After inserting the battery into the motor, press and hold the button for one second to turn it on. Press and hold the button until the motor status light goes down, then release the button, and the motor will turn off. (If the gear rotates while holding the button, that's normal.)

3. Bluetooth Connection

The controller and motor are paired at the factory. Turn on the controller and the motor simultaneously, and the Bluetooth will be paired automatically. (If the indicator lights at both ends continue to flash rapidly, it means pairing is in progress.) After successful pairing, the controller indicator light remains on, and the motor indicator light shows the flashing frequency corresponding to the current speed gear of the motor. (If pairing with other controllers/motors: the Bluetooth of the controller and the motor needs to be reset; see Table 3-4 and Table 2-6.)

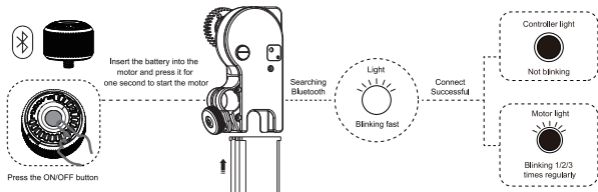

- *1. The recommended control distance of the controller within 100 meters, although the actual control distance can be affected by environmental factors.
- *2. In an environment with strong signal interference, The motor and controller may lose connection. We recommend to shorten the operating distance until the controller and the motor are connected again.

4. Calibration

- (1) Press the ON/OFF button of the Bluetooth controller once, then press and hold it until the motor rotates.
- (2) Press and hold the button on the bottom of the motor for three seconds until the motor rotates.

(1) Press the ON/OFF button of the Bluetooth controller once, then press and hold it until the motor rotates. (see Table 3-3)

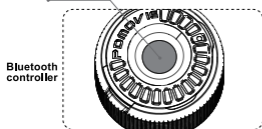

(2) Press the button for three seconds. (see Table 2-1)

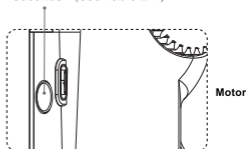

- (3) Manually calibration:
 - A. When the motor gear and the lens gear are completely connected, turn on the motor and turn the lens to the starting point, holding for 0.5 seconds.
 - B. Next, turn the lens ring to the end and hold for 0.5 seconds.
 - C. Finally, turn the lens ring slightly to the middle. Calibration is complete.

(It is recommended to use this method to calibrate unlimited SLR lenses)

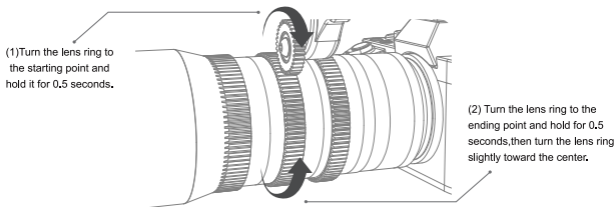

***After completing steps 1 to 4, you can use the controller to drive the motor. Refer to Table 2 and Table 3 for additional command settings.**

Autofocus setup Steps

*Things to know before AF setup

- 1.Please print the focus card on regular A3 or A4 paper and paste it on a non-reflective wall.
- 2.Perform automatic focusing lens calibration under normal indoor lighting conditions, do not do it outdoors.
- 3.Start the motor,do not start the controller,and install the motor correctly according to the installation precautions.
- 4.Select the channel color for saving the lens autofocus data.Double-click the motor button to cycle through 5 channels. (red,yellow,green,blue,white) labels stickers can be used to record which lens corresponds to each channel.
- 5.During AF setup,keep the camera and focus card on the same horizontal line.
- 6.During the AF setup process,make sure there are no other objects between the motor and the Focus Card to avoid errors caused by interference with the motor's scanning.
- 7.During calibration,open the aperture to the maximum setting to ensure the depth of field is at its shallowest state. This allows the focus to be more precise.

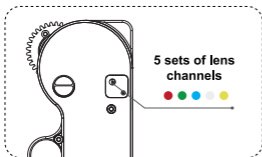

- *1.After switching to a new lens channel,it is necessary to recalibrate the settings.**

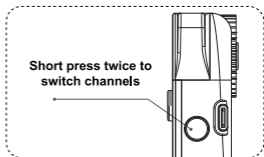

- *2. Switch to the channel that has recorded lens data. After switching,calibrate the lens stroke,and you can run it.**

1.Start AF setup

- 1.Long press the motor button for three seconds to automatically calibrate the lens stroke.Ensure the lens stroke calibration is complete.
- 2.Short press the motor button once,then long press for three seconds to enter autofocus setup mode.

- 1.Manually rotate the lens to the approximate position of the closest focus point on the lens,and move the camera back and forth until the focus card in the camera frame is in focus and accurate. Short press the motor button to mark the first point. At this point,the lens channel indicator light will blinking fast.You can move the camera only after the indicator light stops flashing rapidly and the motor emits a beep sound.

2. Move the camera approximately 0.6 meters backwards and manually adjust the lens focus ring to accurately focus the focus card in the camera frame. Short press the motor button to mark the second AF point. At this point, the lens channel indicator light will blink fast again. You can move the camera only after the indicator light stops flashing rapidly and the motor emits a beep sound.

3. Move the camera approximately 1.5 meters backwards and manually adjust the lens focus ring to accurately focus the focus card in the camera frame. Short press the motor button again, when the indicator light stops blinking fast and the motor emits a beep sound. Means complete the autofocus setup. At this point, the lens channel indicator light will stay on continuously, and the motor will enter autofocus mode.

2. Mark the distance reference

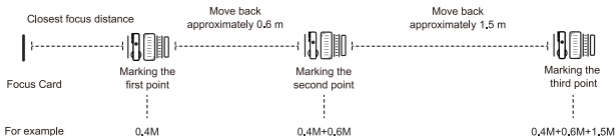

Test the autofocus by checking the accuracy of the focus from 4 meters to the closest focus distance. If it is accurate, the AF setup is complete. If it is not accurate, check if there are any errors in the AF setup steps and try again according to the steps.

The lidar has an effective scanning range of 4 meters and a scanning angle of 28 degrees. When the motor is not connected to the controller and the focused object exceeds the scanning range, the motor will enter a low-power energy-saving mode and automatically move the depth-of-field focus to a position about 30 meters above the scanner.

When the motor is connected to the controller and the object being focused on is outside the scanning range, the motor will automatically move the depth of field focus to a position about 5 meters away on the lens. If the LiDAR does not detect any object within 5 seconds, the motor will again automatically move the depth of field focus to a position about 30 meters away on the lens and maintain it there, at which point the depth of field is close to infinity. When an object re-enters the scanning range, the motor will immediately recover from the low power consumption energy saving mode back to the normal autofocus mode.

*The lens data will be saved in the color channel that performs the calibration action. After the motor restarts, simply set it to the corresponding color channel and automatically/manually calibrate the lens stroke to extract the AF data for the lens. This will initiate the autofocus mode without the need for setup again. Changing the camera will not affect the Af data of the lens.

*When the motor is in autofocus mode, Short pressing the motor button can pause the autofocus, and short pressing it again can restart the autofocus.

Table 1 Motor Automatic Focus Setting











Number of press on the buttons	Function
①  Long press for 3 seconds	AUTOMATIC CALIBRATION OF LENS STROKE
②  Short press a times and then long press for 3 seconds	START MARK
③ <ul style="list-style-type: none"> ● Short press to mark the first point ● Short press to mark the second point ● Short press to mark the third point 	MARKING CAN ONLY BE DONE AFTER IN-FOCUS WITH A REFERENCE OBJECT IN AF SETTING MODE
④  Short press a time after AF setup	PAUSE/RESUME AUTOFOCUS
⑤  Short press twice	SWITCH LENS CHANNEL
⑥  Short press 3 times	ENTER/EXIT PURE MANUAL WIRELESS CONTROL MODE
<p>③ After completing the three AF setup steps, test the autofocus by checking the accuracy of the focus from 4 meters to the closest focus distance. If it is accurate, the AF setup is complete. If it is not accurate, check if there are any errors in the AF setup steps and try again according to the steps.</p> <p>④ This command is applicable when the motor is not connected to the controller. You can manually rotate the lens after pausing.</p> <p>⑥ This command is suitable for users who require pure manual wireless control of the lens to isolate the influence of autofocus data. In this mode, the channel indicator will go down.</p>	

Table 2 Motor Button Command

Number of press on the buttons	Function
①  Long press for 3 seconds	AUTO CALIBRATION
②  Short press a times	EMERGENCY STOP AUTO CALIBRATION
③  Short press 4 times	RESTORE THE LENS STROKE WHEN POWER OFF / REMOVE THE LENS STROKE
④  Short press 5 times	SWITCH MOTOR SPEED (FAST-MEDIUM-SLOW) PULSE FREQUENCY (3/2/1 TIMES)
⑤  Short press 7 times	SWITCH MOTOR ROTATE DIRECTION
⑥  Short press 3 times and then long press for 3 seconds	BLUETOOTH PAIRING
<p>③ To clear the calibrated travel distance, there is no need to restart the motor. Simply press the button 4 times briefly to delete the travel distance. To restore the travel distance after power failure, such as when the motor restarted, simply press the button 4 times briefly to restore the previously calibrated travel distance.</p> <p>④ When the motor speed is switched, the motor indicator will cycle to display the corresponding flashing frequency. Fast = 3 flashes; medium = 2 flashes; slow = 1 flash.</p>	

Auto/Manual mode switch

1. Switch Control Mode

*With the controller and motor connected, rotate the controller to the nearest focus position and pause for 3 seconds. The motor will then enter automatic focus mode;

*Rotate the controller back by a certain angle (more than 10 degrees), pause for over one second, and then return to manual focus control mode.

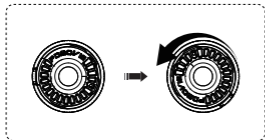

1. When connected, rotate the controller to the closest focus point and pause for 3 seconds. The motor will then enter autofocus mode.

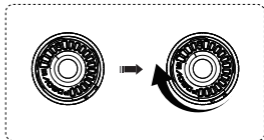

2. When the controller moves away from the closest focus point, it will return to manual focus control mode after a 1-second pause.

2. Switching between front and back focus lock

*When the controller and motor are connected, rotate the controller to the closest focus point and wait 3 seconds. The LiDAR will automatically lock the front focus;

*Switch the motor speed to medium/slow, then rotate the controller to the farthest focus point and wait 3 seconds. The LiDAR will automatically lock the back focus.

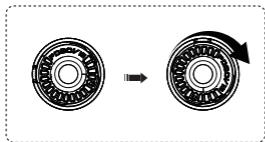



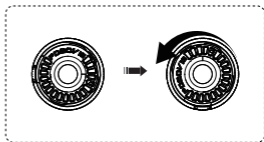



1. When connected, rotate the controller to the closest focus point and pause for 3 seconds. The LiDAR will automatically lock the front focus



2. While connected, switch the motor to medium/slow speed, rotate the controller to the farthest focus and pause for 3 seconds. LiDAR will automatically lock the back focus

Table 3 Bluetooth Controller Instruction of Button

Number of press on the buttons	Function
①  Long press for 3 seconds	ON/OFF
②  Short press a times	A-B LIMITS
③  Short press a times and then long press for 3 seconds	CALIBRATION
④  Short press 3 times and then long press for 3 seconds	BLUETOOTH PAIRING
⑤  Short press 7 times	MOTOR DIRECTION
⑥  Short press 4 times and then long press for 3 seconds	MODE FOCUS ← → ZOOM
⑤	Press once to set point A,press the second to set point B,press the third time to start the automatic operation of point AB,press the fourth time to cancel the automatic operation Run, cancel point AB.(*The speed of automatic operation increases or decreases linearly according to the rotation angle of the knob)

Battery Instructions

1.Battery Pack

The motor battery pack consists of three LI42B batteries, while the controller uses one LIR2477 coin cell battery. Since batteries are consumable parts, if the battery life, capacity, or performance substantially decreases, or if the battery expands or becomes externally damaged during use, it is recommended to replace the battery as soon as possible.

Users can purchase LI42B batteries and assemble them into a LI42Bx3 battery pack, paying attention to the battery contact orientation during assembly.

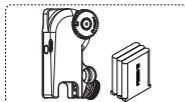

MOTOR SMART & LI42Bx3 Battery

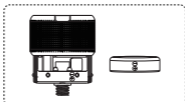

Controller & LIR2477 Battery

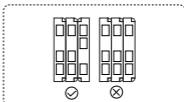

LI42Bx3 Battery

2.Battery Replacement

For changing the controller's battery, please mount the controller on an object that has a 1/4 screw hole.Pull up the shell and make sure the shell is moved to the end. Then use a small Allen key to push out the battery.

Unless unavoidable due to factors such as battery damage or significant capacity decrease, frequent replacement of the controller battery is not recommended. When replacing the battery, ensure that the positive and negative orientations are correct before installation.

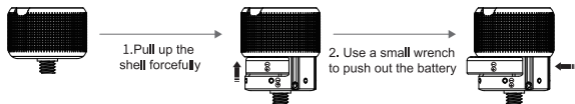

To replace the battery of the motor, please push the battery to the right side first, then pull it out. (Refer to the direction indicated by the arrow icon on the motor.) If the battery is difficult to take out due to slipperiness, please use the BATTERY STICKER to help remove the battery.

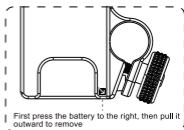

3. Charging Instructions

*Insert the Micro USB cable into the controller's charging port and use a 5V USB charger to charge it.

*The motor and controller batteries plug into the charging device and the batteries are charged via a 5V USB charger. Before charging the LIR2477 battery, you need to pay attention to the installation direction of the positive and negative poles of the battery.

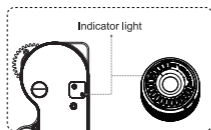
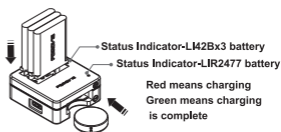

The color of the indicator light	Residual electricity
PURPLE	100% - 95%
WHITE	95% - 75%
GREEN	75% - 50%
YELLOW	50% - 25%
RED	25% - 0%

*Do not stack controller batteries together without any barriers when not in use, as this can potentially damage the batteries.

*After the battery is fully charged, if it will not be used for a long time, please remove the battery to prevent self-discharge.

Type-C interface

1.Type-C charging

The motor can quickly charge the battery through an external power supply via the Type-C interface. (It can be charged to 80% in 15 minutes and to 100% in 25 minutes.)

2.Double Power Mode

When the motor is in high speed mode and the battery is at 100% charge,the motor will automatically enter Double Power Mode.In this mode,the motor output increases,with high speed torque reaching up to 1.5Nm and radar scan rate increasing to 480HZ. Under Double Power Mode, the battery indicator light turns purple. When the battery level falls below 95%,the motor will exit Double Power Mode.By using an external power source through the Type-C port to charge,the motor can stay in Double Power mode for an extended period.(It is recommended to use an external power supply with an output power of at least 5V3A for charging)

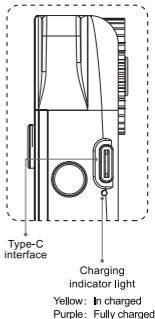

REMOTE AIR RIG Installation Note

1、Installation

First install the Bluetooth thumb wireless controller into the slot of the REMOTE AIR RIG large handwheel extension device (*be sure to install it all the way).Press the controller gently and turn it clockwise twice to make sure the 1/4 screw of the controller is installed into the slot of the large handwheel.Then continue to turn the large handwheel until the controller cannot rotate,then the installation is complete.

2、Disassembly

First,rotate the large handwheel counterclockwise to the limit of the controller,and then continue to rotate counterclockwise with a little force until the 1/4 screw of the controller is completely out of the slot of the large handwheel. At this time,there is a "click" sound, and it can be pulled out.

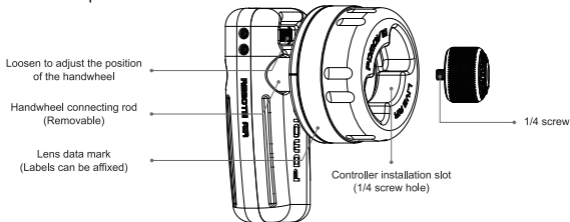

REMOTE AIR APP

1、APP download

The app supports only manual control functions and does not support autofocus data interaction. Please take note.

- Users can use APP to connect and control up to 6 Bluetooth motors.
- Search for PDMOVIE or REMOTE AIR in the Apple App Store to download.
- Log in to the official website www.pdmovie.com with your mobile phone, and enter the APP download page of support to download and install the APP.
(APP currently only supports IOS system)

2.Connect

Before use the APP connect to the motor, please make sure that the controller is turned off. And make sure that the APP is not running in the background. The specific connection steps are as follows:

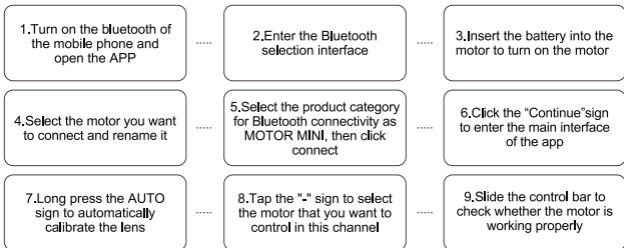

***If you need to connect multiple Bluetooth motors, repeat steps 3 ~ 5. Step 7: Automatic lens calibration can also replace by manual lens calibration.**

***For more information about APP, please enter the APP SET interface and select HELP to view more detailed tutorials.**

Notice

1. Emergency stop calibration: The motor skips teeth during the automatic calibration process, resulting in the phenomenon of non-stop rotation. Just click the motor button to terminate the automatic calibration immediately;
2. When the motor is not calibrated, it cannot be used. For individual lenses that have excessive damping or are not smooth or have unlimited positions, and when the motor cannot complete automatic calibration, you can use the manual lens stroke calibration function.

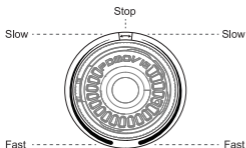

In ZOOM mode
there are three speed control gears.



Short press the controller button
for 5 times to change speed.

3.The controller defaults to FOCUS mode. If it is switched to ZOOM mode, it will be divided equally based on the rotation of the wheel by 300 degrees, and the middle 10 degrees will be the stationary position. Turn left to move forward, turn right to move backward. The propulsion speed is linearly adjusted according to the angle of rotation.

4.When the rotating stroke of the motor does not match the calibrated stroke,please check whether the indicator light of the Bluetooth controller is blue and the color of the current battery flashes alternately. If the above state occurs, it means that the controller has set the point A-B stroke Limit,you need to briefly press the controller button to start the A-B automatic operation,and then press it again to cancel the automatic operation and cancel the A-B point travel limit.(*A-B point command logic: click the 1st time = set point A; click the 2nd time = set point B; click the 3rd time = start the automatic running of the A-B point cycle; click the 4th time = stop the automatic operation Run and cancel the A-B point limit.)

5.The PD-BTMP-SP Bluetooth motor supports adjusting the three-speed response speed.Short press the motor button 5 times to switch the three-speed response speed cyclically. The speed gears are slow,medium,and fast.When Bluetooth is connected and the motor speed is switched,the motor indicator light will flash in a cycle at the corresponding flash frequency and will not be displayed when not connected. Fast = 3 flashes; medium = 2 flashes; slow = 1 flash.

6.Pressing the motor button three times briefly to enter pure manual wireless control mode and rotating the controller to a non-limit position to enter manual wireless control mode are different. The pure manual wireless control mode is not affected by the controller pausing at the limit position. Choose this mode when you have no need for autofocus.

7.Regarding battery maintenance: When the product is not being used for an extended period,it is recommended to check the battery once a month to ensure there is adequate charge;if the battery stays at a low or zero state of charge for a prolonged time,it can lead to reduced capacity or even damage.If the battery appears swollen, stop using it immediately to avoid having it get stuck in the battery compartment and difficult to remove.

LIVE AIR 3 SMART

(PDL-AFX-RA-SP)

PDMOVIE Technology Co., Ltd.

Web: www.pdmovie.com

E-mail: pd@pdmovie.com

Instagram: [pdmovie_official](#)

Youtube: [PDMOVIE](#)

Facebook: [PDmovie](#)

©2023 PDMOVIE All rights reserved.