



LL COMPANY

2. DIMENSIONS & INSTALLATION  
GUIDE

# GUIDE CONTENTS

## Information & Dimensions

3. List of hardware components
4. Top Hardware dimensions
  - Full Roller
  - Hook Roller
  - Hook Over
5. Bottom Hardware dimensions
  - Wheeled Foot
  - Non Slip Foot
6. Dimensions continued;
  - Rail dimensions
  - Curved rail dimensions
  - Handrail dimensions and information
7. Rail Bracket dimensions
8. Ladder dimensions
  - Ladder heights
  - Make your own ladder information
9. Allowances & Safety
  - Clearance above ladder
  - Make your own ladder information
  - Ladder Safety

## General Installation Guide

10. Step 1: Rail Installation
11. Step 2: Ladder Assembly (if applicable)
12. -Step 3 Ladder Hardware Installation

# COMPONENTS LISTED

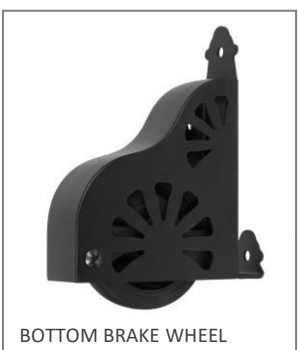

# HARDWARE DIMENSIONS

## FULL ROLLER

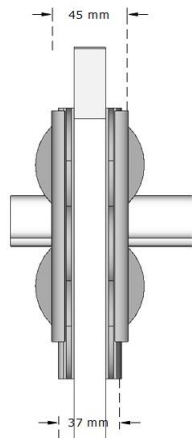

FRONT VIEW

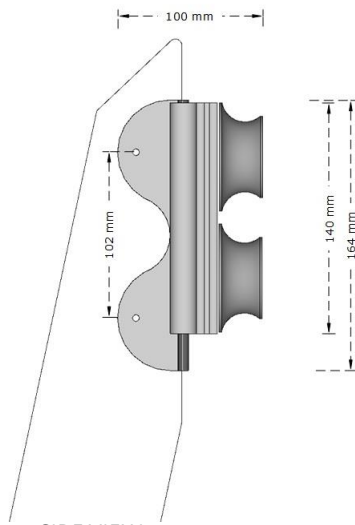

SIDE VIEW

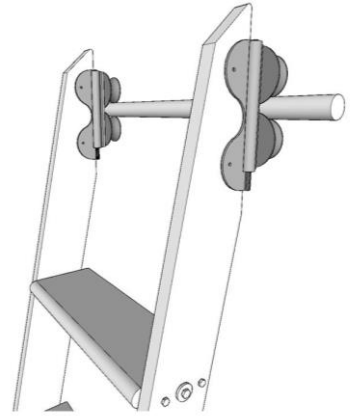

## HOOK ROLLER

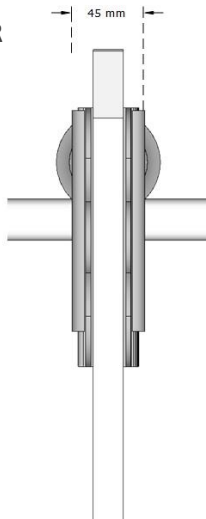

FRONT VIEW

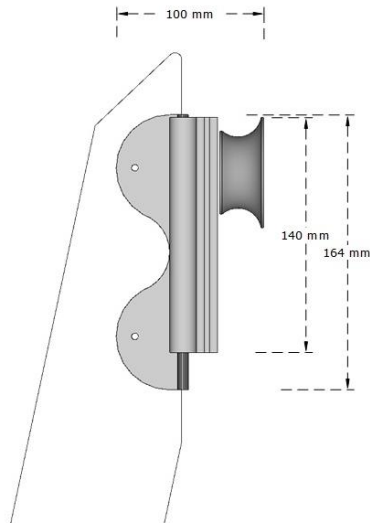

SIDE VIEW

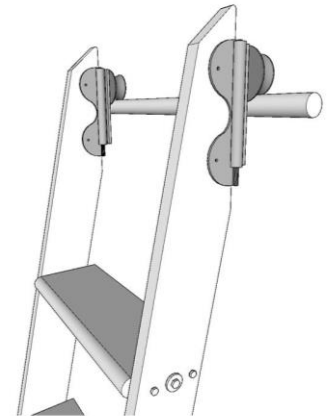

## HOOK OVER

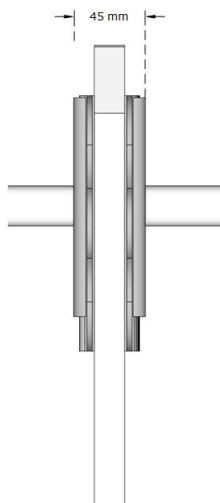

FRONT VIEW

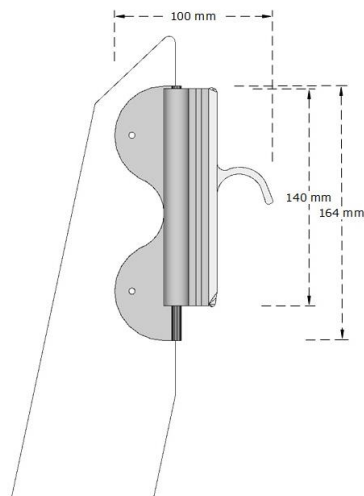

SIDE VIEW

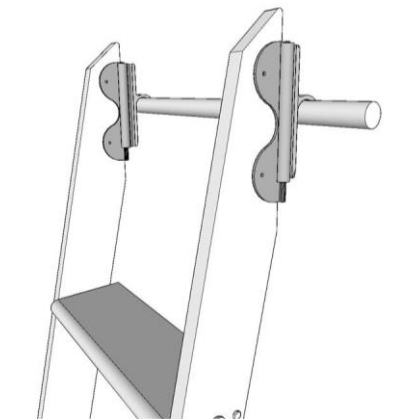

# HARDWARE DIMENSIONS

## WHEELED FOOT

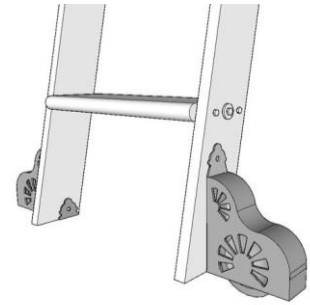
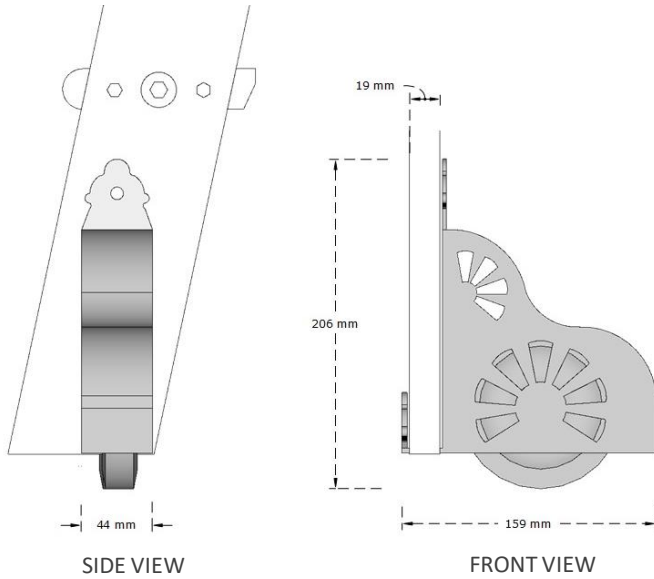

Braking bottom wheels limit ladder movement while standing on ladder, the brakes will engage when as little as 75 lbs. is applied

## NON SLIP FOOT

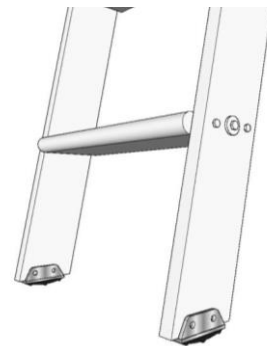
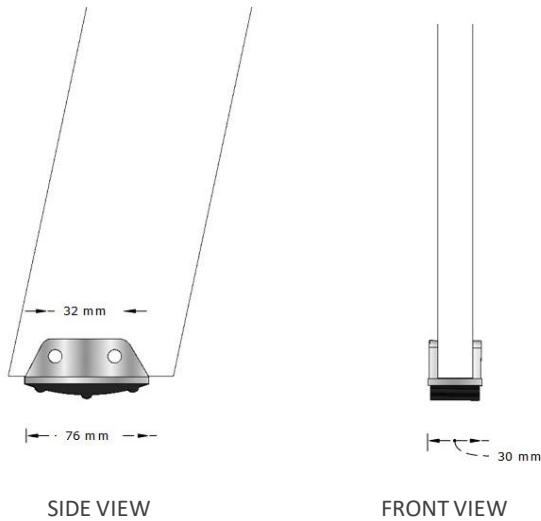

# RAIL & BRACKET DIMENSIONS

## RAIL DIAMETER

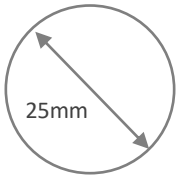

Solid Aluminium

## RAIL LENGTHS



6FT RAIL LENGTH  
(1828.8mm)



8FT RAIL LENGTH  
(2438.4mm)

## 16 INCH CURVED CORNER RAIL

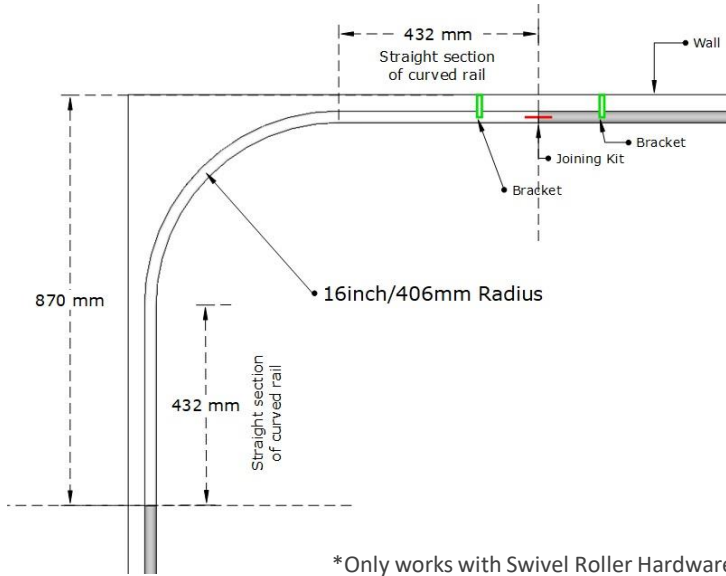

# HANDRAIL DIMENSIONS

Adding a pair of handrails to your ladder is optional extra.

- 19mm timber thickness
- 16mm radius ends
- Predrilled holes at each end
- In the climbing position, the ladder's rolling wheels are approximately 790mm from the wall

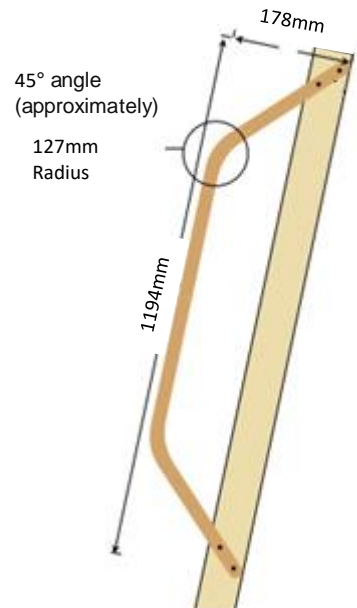

# BRACKET DIMENSIONS

## HORIZONTAL HOOK BRACKET

\*for **hook rolling & hook-over** hardware

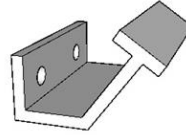
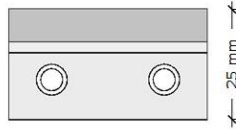
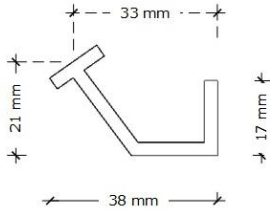

\*Brackets should be spaced no more than 3ft (914mm) apart.

## VERTICAL HOOK BRACKET

\*for **hook rolling & hook-over** hardware

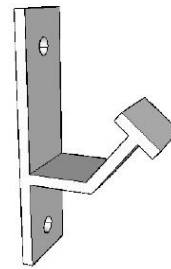
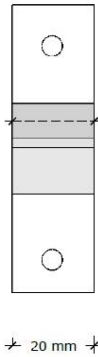
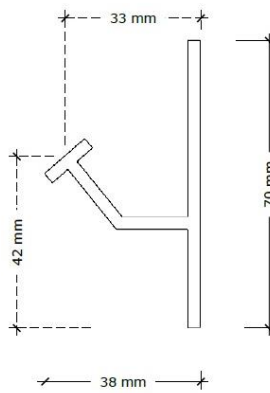

## HORIZONTAL ROLLER BRACKET

\*for full rolling & swivel rolling hardware

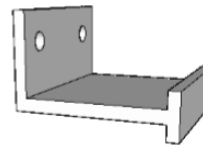
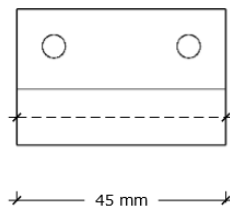
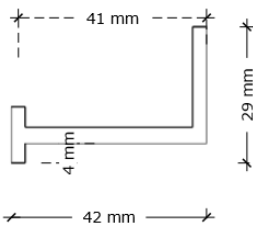

## VERTICAL ROLLER BRACKET

\*for full rolling & swivel rolling hardware

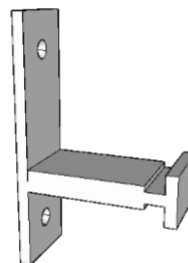
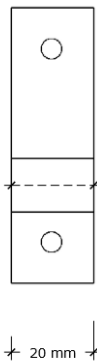
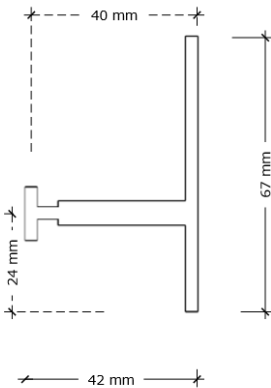

# LADDER DIMENSIONS

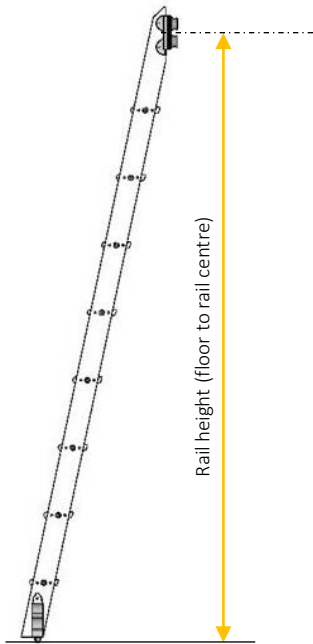

LADDER HEIGHT	RAIL HEIGHT (from floor to centre of rail)	BESPOKE HEIGHT (work out which bracket your height sits in)
8ft Ladder	2311mm	“Up to 8ft”
9ft Ladder	2616mm	“Up to 9ft”
10ft Ladder	2920mm	“Up to 10ft”
11ft Ladder	3226mm	“Up to 11ft”
12ft Ladder	3531mm	“Up to 12ft”
13ft Ladder	3835mm	“Up to 13ft”
14ft Ladder	4140mm	“Up to 14ft”

Work out which height ladder is best for your space.

Choose from the standard height ladders using the listed rail height, FFL to the centre of the rail.  
If the standard height ladders won't work for your needs let us know your rail mount height and we can make a custom height ladder for you.

\*Rail Mount Height – The height distance FFL to the centre of the rail.  
\*FFL – From floor level.

## MAKE YOUR OWN LADDER

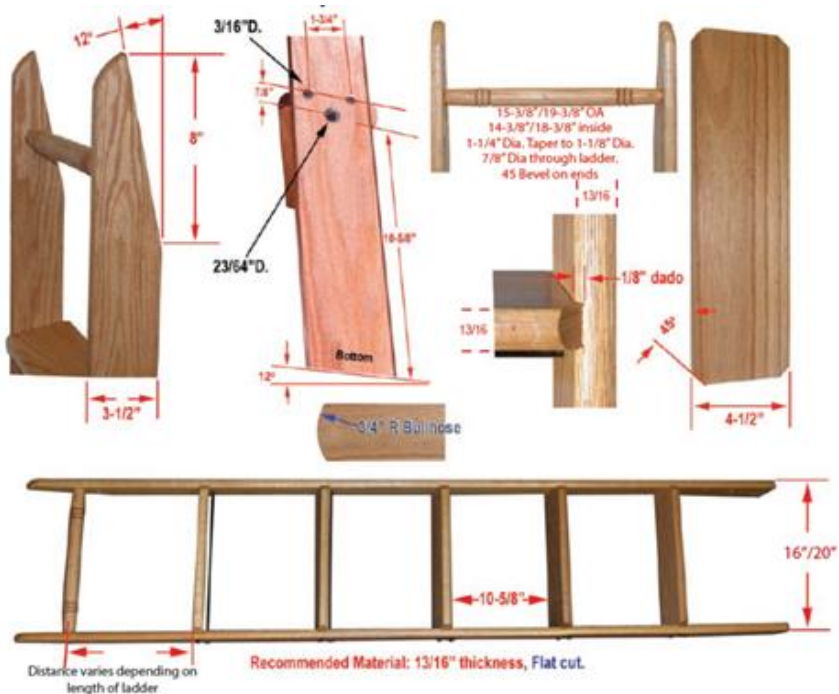



# PLANNING

## CLEARANCES & ALLOWANCES

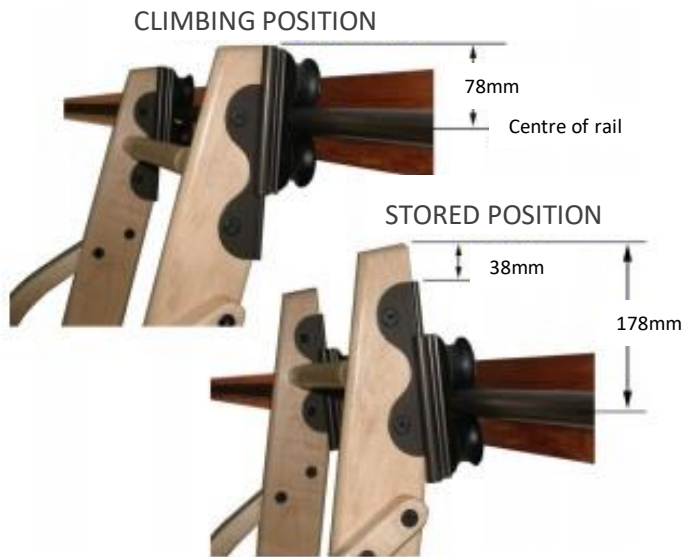

### LADDER CLEARANCES

- In the stored position, there is 178mm from the centre of the rail to the top of the ladder
- In the climbing position, there is 78mm from the centre of the rail to the top of the ladder
- In the climbing position, the ladder's rolling wheels are approximately 790mm from the wall

## LADDER SAFETY

### DO's

- Always inspect the ladder prior to using it and check it is in good condition
- Make sure there is enough room to safely step off the ladder and keep the area clear.
- Always maintain a 3-point (two hands and a foot, or two feet and a hand) contact on the ladder when climbing. Keep your body near the middle of the step and always face the ladder while climbing.
- Make sure the ladder is in a safe environment on a stable and level surface.
- Make sure the ladder is in the correct climbing angle prior to climbing.
- Make sure the ladder treads are flat before you climb the ladder.
- Make sure you do not lean away from the ladder and that you keep your weight between the ladder uprights.

### DONT's

- Never overload the ladder or carry loads on ladders.
- Do not overreach from the ladder or lean your weight outside of the ladder sides.
- Never have more than one person on the ladder at one time.
- Never stand ladders on moveable objects or on uneven ground.
- Never climb the ladder when it is in vertical or stowed position.
- Do not use the top step/rung of the ladder.
- Do not spend more than 20minutes on the ladder

# GENERAL INSTALLATION GUIDE

## **Step 1: Rail Installation**

Special application notes:

- Leave at least 7" of clearance between the centre of the rail and the ceiling, crown moulding or other overhanging protrusions when the ladder is in the stored position (close to the wall/cabinet/bookshelf). In the climbing position, a minimum 3" clearance between the centre of the rail and any upper cabinet doors is required to be able to open the upper cabinet doors.
  - Do not mount rail brackets directly onto a drywall surface. Always mount these brackets to solid wood, predrilling the holes in the wood is advisable to avoid splitting the wood.
1. Establish the height of where the centre of the rail is to be installed and mark the location where the bottom of the mounting bracket will be located (depending on which type of bracket is used, the distance between the centre of the rail and the bottom of the bracket will change, see dimensional specs on the bracket those measurements). Verify with a quality levelling device that the lateral locations of the brackets are level and true.
  1. To splice rails together using the Quiet Glide splice kit (QG.41) complete the following steps:
    - Insert the roll pin halfway the length of the pin into one of the rails
    - Slide the steel bar halfway into the rail and tighten 2 of the set screws to lock the bar and roll pin onto the rail.
    - Line up the roll pin hole and slot for the steel bar on the other rail and slide the rail over the pin and bar till a tight connection is made between rails.
    - Complete the splice by tightening the remaining 2 set screws 3.
  1. Slide all the brackets to be used onto the rail, recommended spacing of the brackets is approximately 32" apart.
  2. Secure each bracket to the wood surface with the screws included.

CONTINUED.....

# GENERAL INSTALLATION GUIDE

## **Step 2: Ladder Assembly (if applicable)**

(It is recommended that the ladder rail sides and steps are sanded slightly with a 220 grit sand paper just prior to applying the finish (stain, paint, clear coat sealer) on the ladder.

It is also much easier to finish the ladder prior to assembly, taking care to protect the inside of the dados of the side rails and the ends of the steps from the applied finish that would prevent a good strong glue bond between the steps and the side rails)

1. Stand on edge one of the ladder side rails on a flat surface, dados facing away from you.
2. Insert one of the steps into the dado, aligning the compound mitre of the step flush with the dadoed surface of the side rail. If not flush, flip and/or rotate the step until it lines up properly with the side rail.
3. Once proper alignment of the step is established, apply a thin film of quality woodworker's glue to the end of the step and also in the dado.
4. Using the supplied 1-3/4" washer-head screws, secure the step to the side rail through the predrilled holes on the side rails. Assemble the remaining steps in the same manner.
5. Once all the steps are assembled onto one of the side rails, position the side rail on its side with the steps pointing up.
6. Apply a thin film of glue on the ends of each step and in the dado of the other rail, along with the holes in the sides of the rail (for the top turned rung) and the ends of the top turned rung.
7. Properly align each step as well as the top turned rail into its corresponding dado/hole, use the supplied 1-3/4" washer-head screws to fasten the steps into place.
8. To install the step support rods, push a nut cap (used with the step support rods) in the predrilled hole on the side rail. Slide the step support rod through the hole on the opposite side rail and partially thread it into the nut cap. Install the other nut cap and using two 5mm Allen wrenches tighten each side simultaneously so that there is equal amounts of thread on each end of the rod into each nut cap.

CONTINUED.....

# GENERAL INSTALLATION GUIDE

## **Step 3 Ladder Hardware Installation**

### **Top Ladder Hardware**

1. Align the top roller guide on the bevelled portion of the top of the ladder so that the top turned rung is centred between the bolt holes on the side of the hardware.
2. Mark on the bevelled flat surface of the ladder, the top of the hardware. Measure from the tip of the ladder to this mark. Scribe a similar mark on the other ladder side rail so that the location of the top roller guide will be identical on both of the ladder side rails.
3. Locate the top roller guide onto the ladder rail, lining up this hardware on the scribed line. Using a Vix bit or similar self-centring drill guide, drill a pilot hole into the edge of the ladder for the (2) #10 x 3/4" Flat-head, Phillips-drive screws, and secure each top roller guides to the top of the ladder.
4. Using a 1/4" drill bit, drill out the holes for the 1/4-20 KD bolts on the sides of the ladder.  
Recommended procedure for this:
  - Using the holes in the top roller guide as a drill guide, drill a 1/4" hole half way through the thickness of the ladder slide rail.
  - Drill the same hole on the opposite side of the top roller guide, producing a 1/4" through hole in the ladder side rail.
  - Follow this same procedure for all 4 through holes and complete the assembly by securing the top roller guide with the supplied 1/4-20 KD bolts and acorn nuts.

### **Bottom Ladder Hardware**

1. Place the bottom roller housing onto the bottom of the ladder using the "U" bracket portion of the housing. Verify that the bracket is flush with the bottom of the ladder. Because of the 12-degree angle of the bottom of the ladder this will align the housing diagonally across the ladder side rail.
2. Mark the location of the "U" bracket on the bottom of the ladder and at the same time mark on the side of the ladder the location of the top mounting hole of the bottom roller housing. Measure these marks and transfer these measurements to the other ladder side rail so that the hardware will mount identically on both ladder side rails.
3. Using a 1/4" drill bit, drill a through hole in the ladder side rail for the 1/4-20 KD bolt.
4. Predrill the ladder side rail for the #10 x 3/4" screw
5. Install both the bottom roller guides using the included screws and KB bolts and acorn nuts.

---

If you need any further assistance with your installation  
please contact the team on  
[info@thelibraryladdercompany.co.uk](mailto:info@thelibraryladdercompany.co.uk)

If you need any further assistance please contact the team  
on [info@thelibraryladdercompany.co.uk](mailto:info@thelibraryladdercompany.co.uk)



LL COMPANY  
[www.llcompany.co.uk](http://www.llcompany.co.uk)