

Single & Dual

CAN CARRIER



Applications

installation instructions

These installation instructions apply to the following CBI Off Road products

CBI Dual Can Carrier – For use with Single & Double Swing arms

CBI Single Can Carrier – For use with Single & Double Swing arms

IMPORTANT!

THANK YOU for purchasing this CBI product. Please read through this entire document before proceeding with installation. If you are not confident in your mechanical skills, please seek the help of a professional to perform the installation. Check your packages immediately upon arrival to ensure that everything listed is included, and to check for damage during shipping. ***If anything is missing or damaged, or if you need technical assistance with any aspect of this installation, call CBI at (208) 528-0664 as soon as possible.***

IMPORTANT!

If your CBI product comes as unpainted, bare steel or aluminum. You will want to either powder coat or paint prior to final installation, however it is very important to PRE-INSTALL the unpainted product first, following these instructions, BEFORE painting or powder coating any of the components! This will ensure that all parts are correct and any incidental trimming or drilling will have been done prior to coating. Also, it will give you a practice run to familiarize yourself with the process, to lessen the likelihood of damaging the finish during final installation.

CBI Off Road is NOT RESPONSIBLE for paint or powder coating costs, damage to paint or powder coating, or costs associated with inadvertently painting or powder coating components that are defective or were shipped or assembled in error. It is the customer's responsibility to pre-install and verify that all parts are correct prior to paint or powder coat

Hardware: What is included

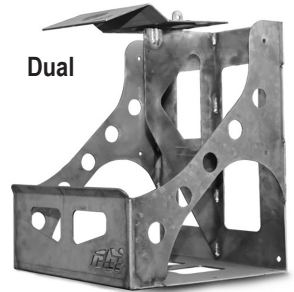
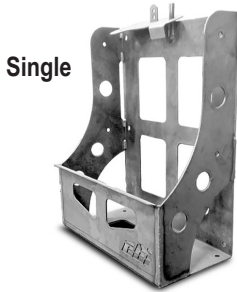

A | 4 5/16" -18 x 3/4" SS BUTTON HEAD

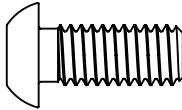

B | 4 5/16" STEEL SAE FLAT WASHER (ZINC)

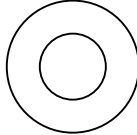

C | 4 5/16" SS SERRATED HEX FLANGE NUT

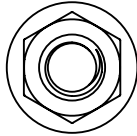

D | 1 1/2" SS WING NUT

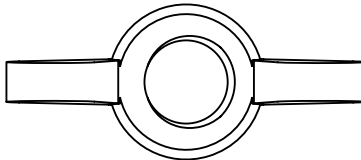

E | 1 1/2" STEEL USS FLAT WASHER (ZINC)

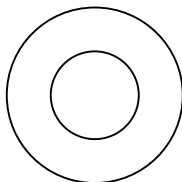

Questions?

Call: 866-522-0697

Email: info@cbioffroadfab.com

Fig1

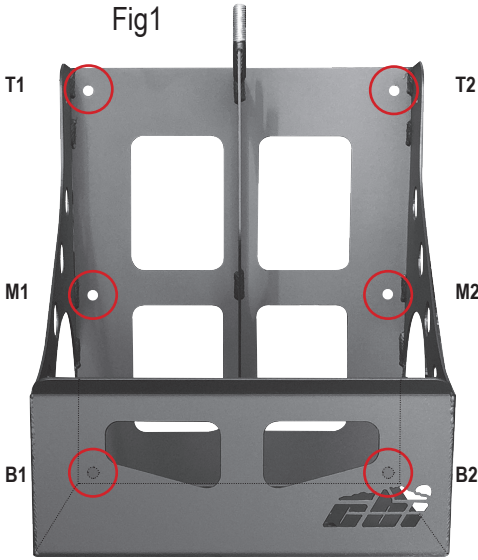

Installation

There are 6 mounting holes on the back of the Can Carrier: **T** (TOP), **M** (MIDDLE), **B** (BOTTOM).

You will only use 4 of these holes to mount the Can Carrier. Use the images in this guide to mount the Can Carrier in a way that best fits your setup.

Use the 5/16" button head bolts to mount the Can Carrier to the swing arm with the 5/16" nuts on the back side of the swing arm.

Single Swing

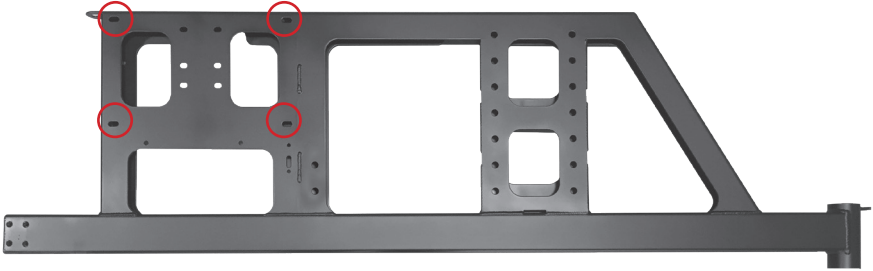

Dual Swing

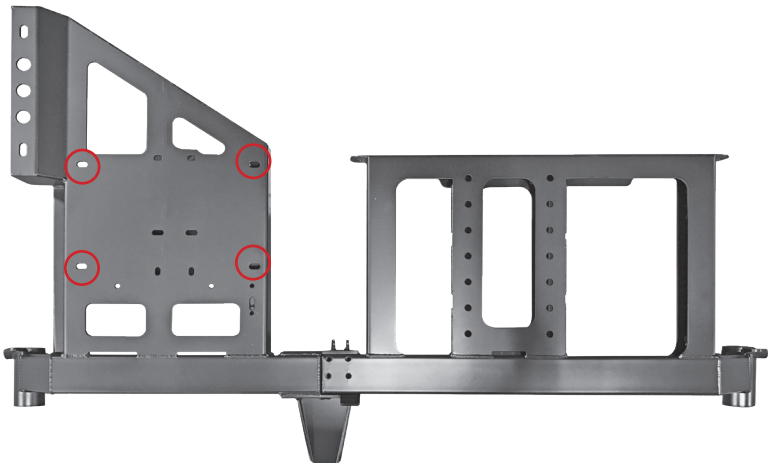

Single Swing

High mount

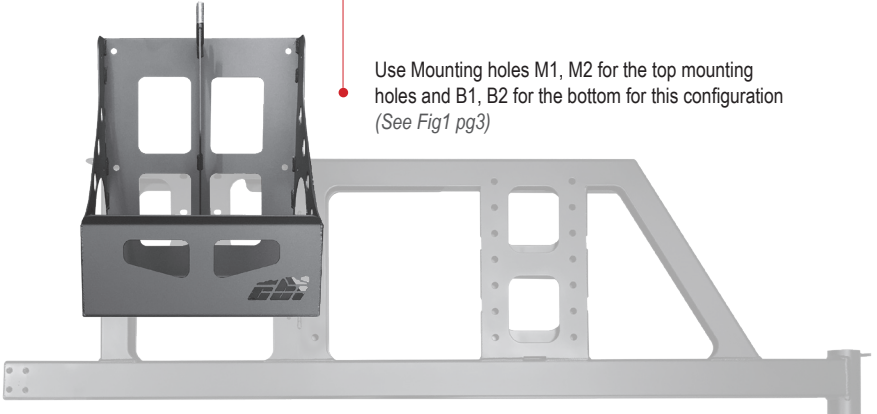

Use Mounting holes M1, M2 for the top mounting holes and B1, B2 for the bottom for this configuration
(See Fig1 pg3)

• Room for license plate

Low mount

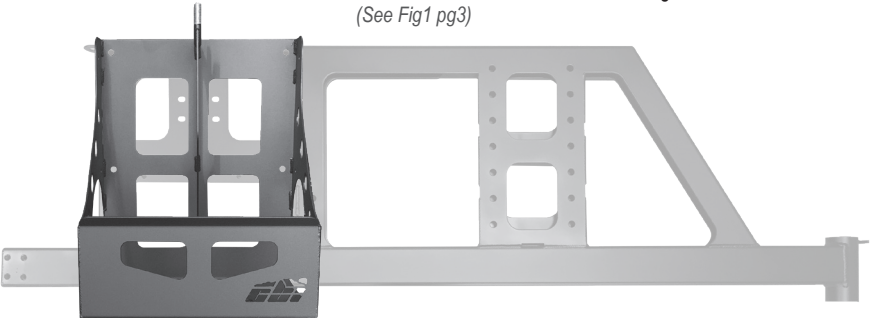

Use Mounting holes T1, T2 for the top mounting holes and M1, M2 for the bottom for this configuration
(See Fig1 pg3)

Dual Swing

High mount

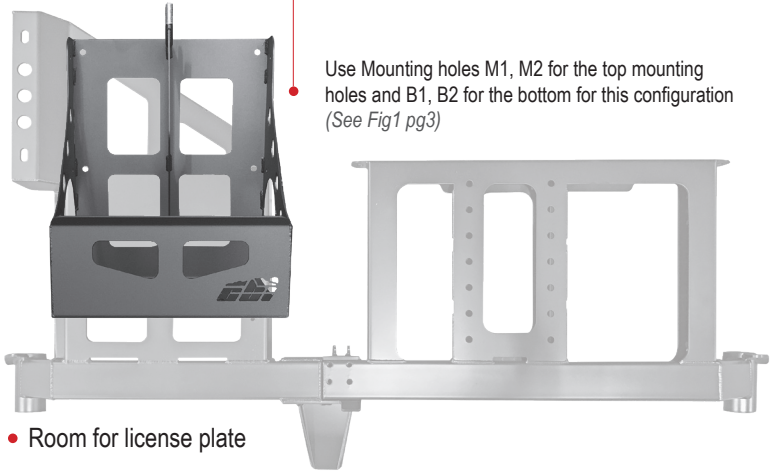

Low mount

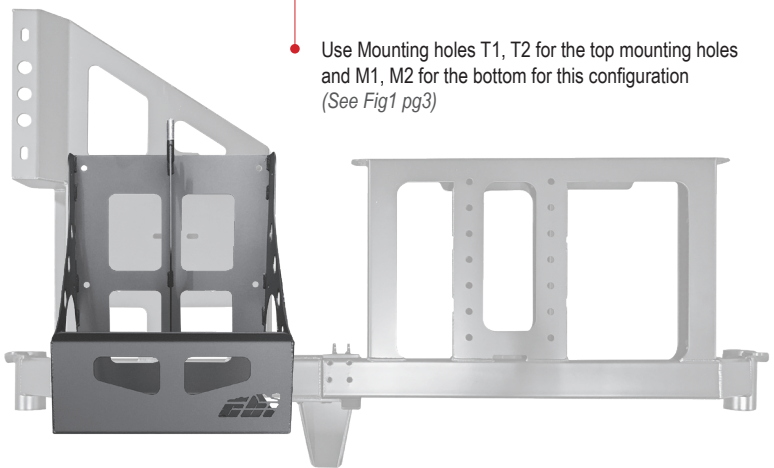



792 E Iona Rd.
Idaho Falls, ID 83274
cbioffroadfab.com
208.528.0664