

Anycubic Photon Workshop

Usage Instructions

Copyrighted by "Shenzhen Anycubic Technology Co., Ltd ", all rights reserved.

Team **ANYCUBIC**

Contents

01 Installation	3
02 Overview	5
03 Settings	6
1. Import	6
2. Machine & Resin Settings	6
3. Slice Parameter	7
4. Web Printer	11
04 Introduction to Functions	13
1. View Changing	13
2. Model Changing	13
3. Hollow and Fill	14
4. Punching	15
5. Text Paste	16
6. Split Model	17
7. 3D Face Reconstruction	18
05 Support Settings	20
1. Shape Editing	21
2. Support Adding	25
3. Export Support Information	28
06 Export Sliced File	30

Installation & Update

Anycubic Photon Workshop installation package is located in memory stick, please install and update the software as following steps.

1. Installation

• Windows

Close the anti-virus software before installation. Open the suitable package and then follow the guide as shown below.

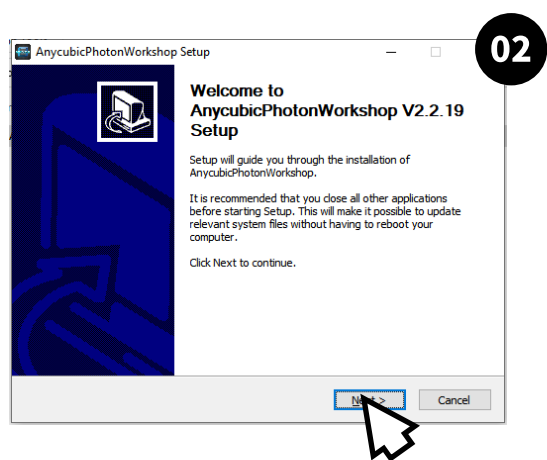
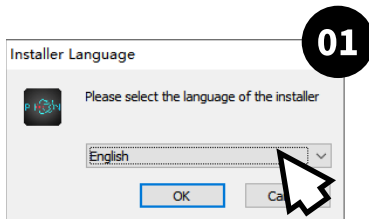

• Mac

Double click the package. Then, open Finder and drag Anycubic Photon Workshop to Application.

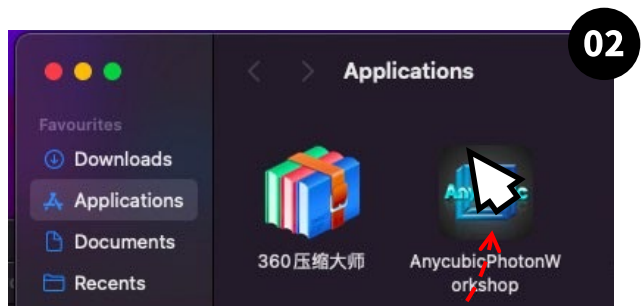

Drag Anycubic Photon Workshop to application

Installation & Update

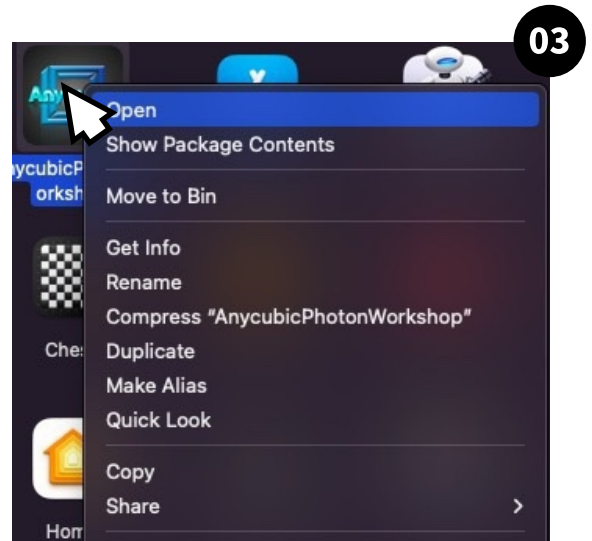

At last, press "Control"+ click it to open the software.

2. Update

If a new version is released, it will be a popup asking you to update when you open the software. You can also click "Help"→"Check Update" to check whether the software update to the latest version.

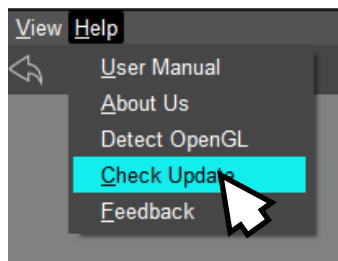

Note: Anycubic Photon Workshop and its instructions may be updated irregularly. Please visit www.anycubic.com for the latest updates.

Overview

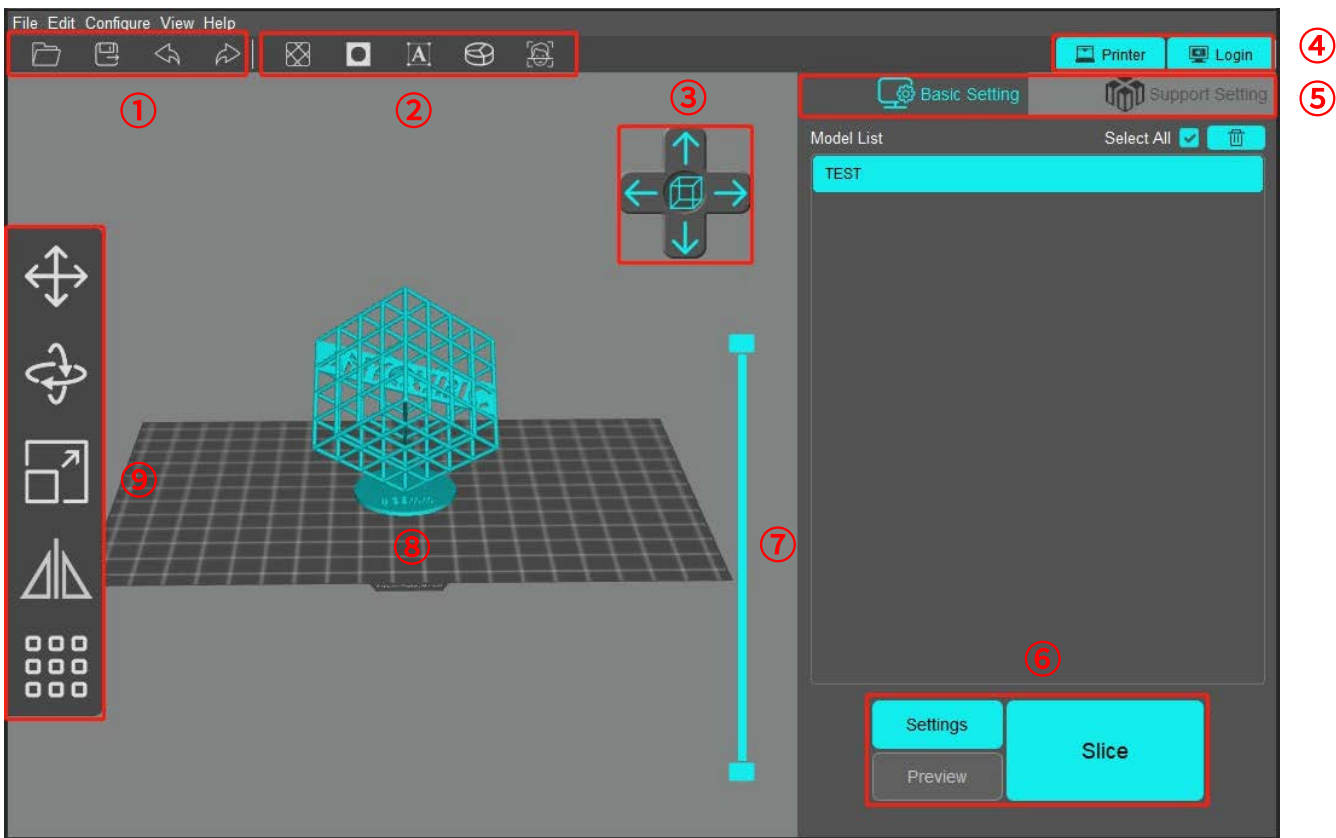

- ① From left to right are open, save, undo and redo.
- ② From left to right are hollow and infill, punching, text paste, split model and 3D Face Reconstruction.
- ③ Click to switch views.
- ④ Click to log in Anycubic Cloud and add printers.
- ⑤ Switch to basic settings or support parameters.
- ⑥ Set machine type, resin type and printing parameters; preview sliced file; slice button.
- ⑦ Drag the slider to preview each layer of the model.
- ⑧ 3D model preview.
- ⑨ Manipulations include move, rotate, scale, mirror and layout.

Settings

1. Import

Import your own three-dimensional format model, i.e. STL or OBJ file, etc.

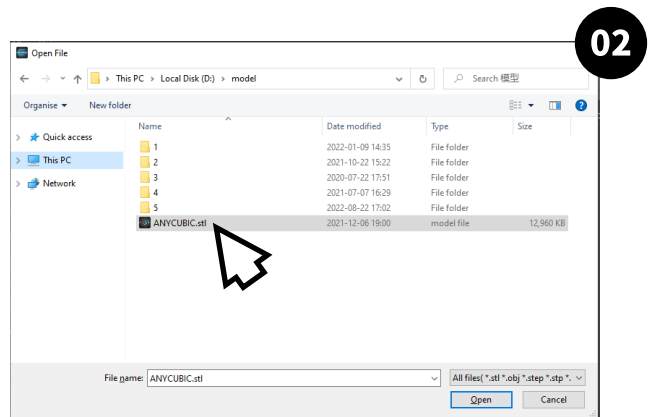
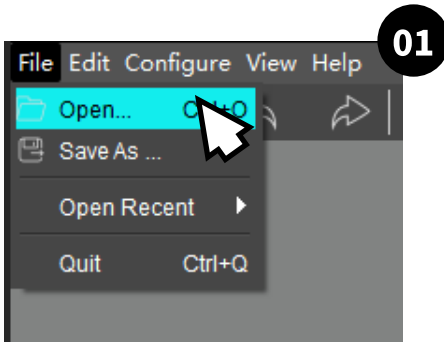

Select model file

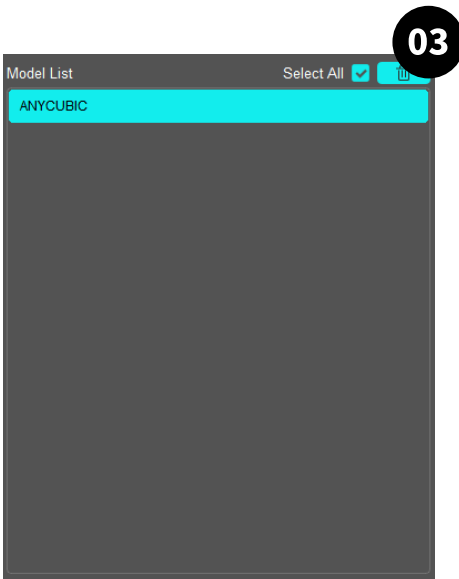

Check model in the list

Settings

2. Machine & Resin Settings

① Machine settings

Click “Settings” in the lower right corner and select the type of your machine in machine interface. Different machine types have different parameters, please choose the machine you use to avoid print failure.

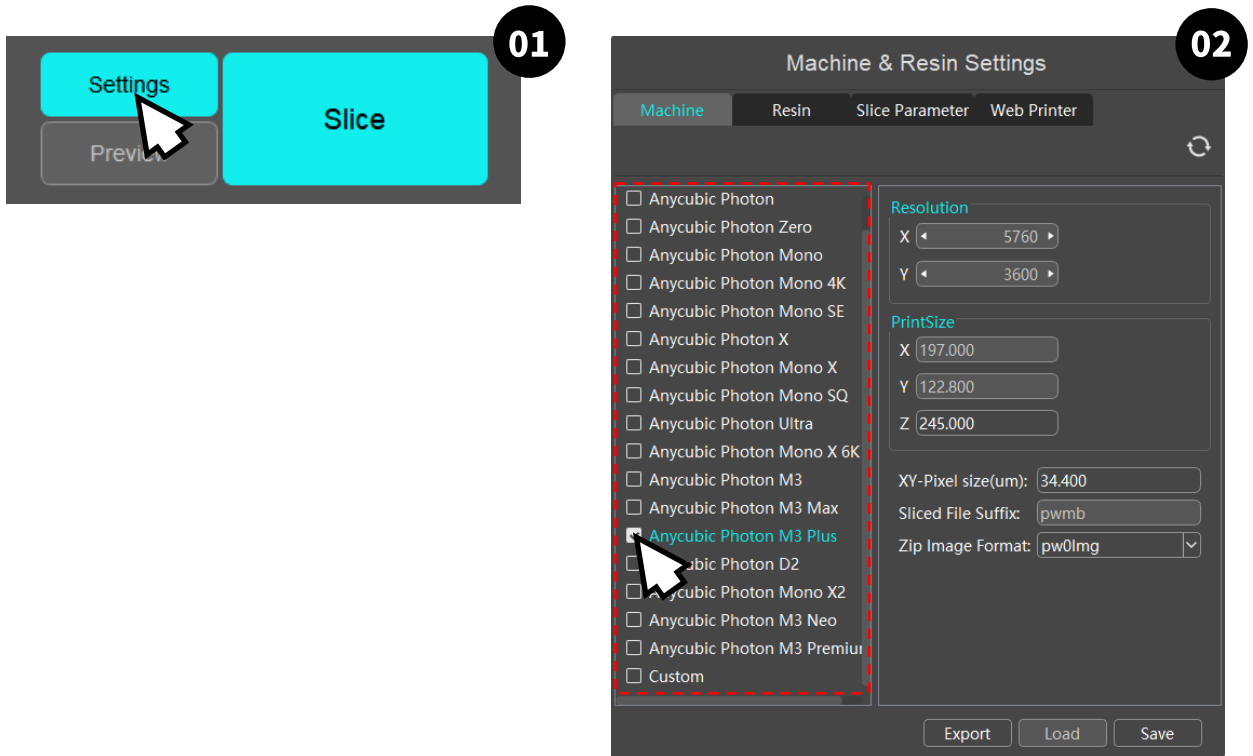

Select your 3D printer

② Resin Settings

Set the resin type you use to calculate the cost of resin. Choose the resin type you use or click “+” to add the resin type. Then, Click “Save”.

3. Slice Parameter

Set slice parameters according to your requirement in this interface. Then click “Save” to apply it, or click “Export” to export profile. The recommended parameters is shown in **User Manual- Recommended Printing Parameters**.

① Slice parameter instruction

- **Normal Exposure Time:** The length of normal exposure time depends on UV power, complexity of model, resin materials and so on. Underexposure may cause uncured detail, overexposure may affect accuracy of model.
- **Off Time:** The UV light will be off for a certain time between each layer. The longer off time allows resin with poor fluidity to reflow.
- **Bottom Exposure Time:** The longer the bottom exposure time is, the easier the bottom layers of the model stick to platform.
- **Bottom Layers:** The bottom layers need to be exposed for longer time to stick model to platform tightly. The bottom layers may be larger than normal layers.
- **Layer Thickness:** The thinner the layer, the better the accuracy of Z-axis direction. The thicker the layer, the longer the exposure time for each layer.
- **Z Lift Distance:** The model requires enough distance to be separated from the FEP film.
- **Z Lift Speed:** If the lift speed is too fast, the model will be broken and supports may also be damaged due to the separation force.
- **Z Retract Speed:** If the retract speed is too fast, the printing quality may be damaged.

Settings

- **Anti-alias:** A higher grade of anti-alias value could enhance the ability to smooth the edges for each layer during printing, thereby resulting better surface of the printed objects. A higher grade of anti-alias value also means longer slicing time and larger files.
- **Surface Abrazine:** Only when anti-alias value is 1 can you check this option to get a matte surface.

When anti-alias value is larger than 1, you can set the grades of gray level and image blur according to the requirement.

- **Gray Level:** The higher the gray level, the brighter the pixels of anti-alias.

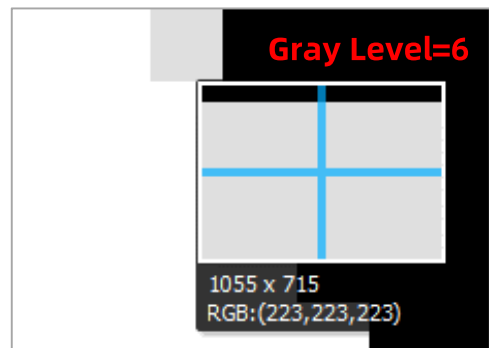
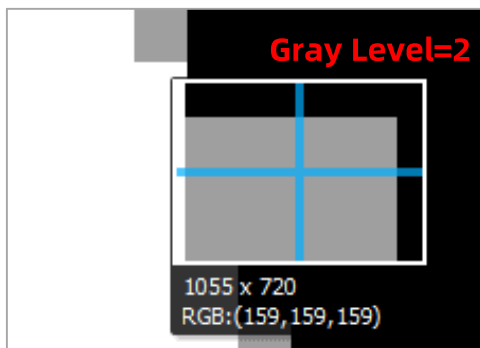

- **Image Blur:** It blurs the edge of image to achieve the natural cohesion. The higher the grade of image blur, the more blurry it is.

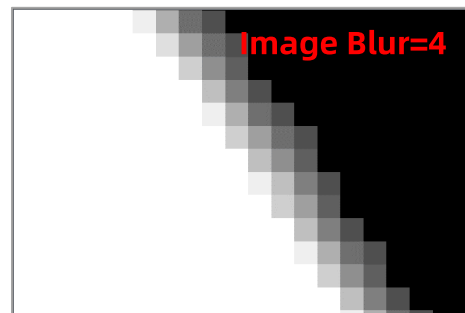
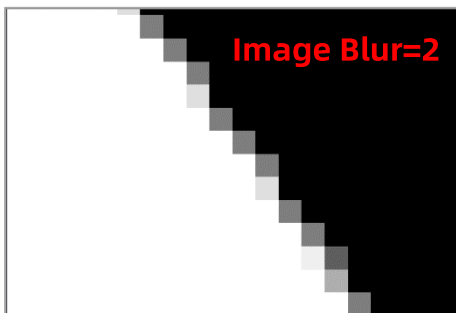

In the process of printing, please comprehensively consider the grade of anti-alias, gray level and image blur according to the actual requirement to get the best surface quality.

Settings

② Advance

In basic mode, Z lift time, Z lift speed and retract speed of the bottom layers are the same with those of normal layers. However, if you want to reduce the printing time or achieve better print effect, switch to advance mode to set different parameters of Z-axis moving in different stages and layers.

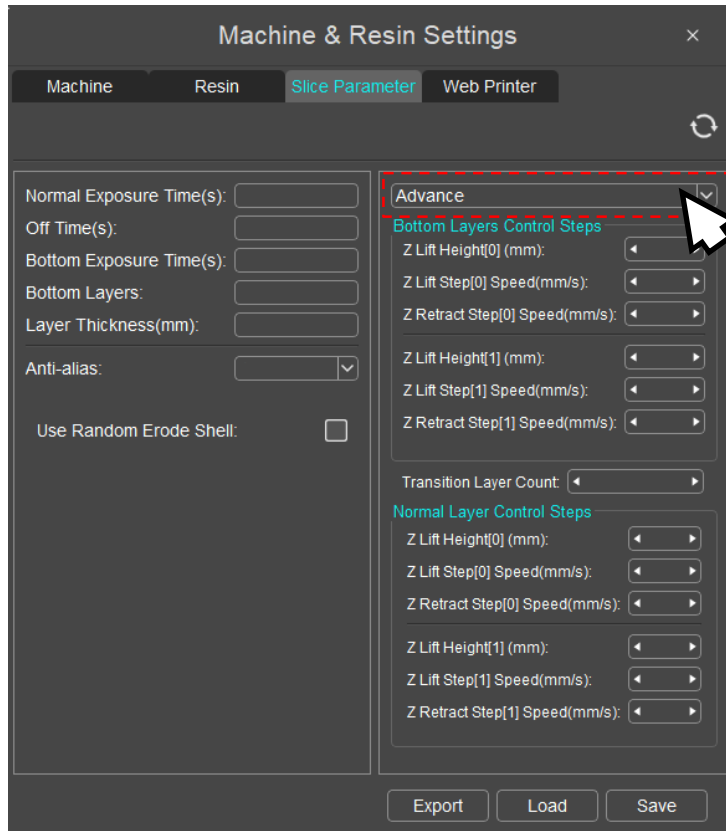

Switch to advance mode

- **Bottom layers control:** To set Z lift height, Z lift speed and Z retract speed of the bottom layers.
- **Normal layer control:** To set Z lift height, Z lift speed and Z retract speed of the normal layers.
- **Transition layer count:** The transition layers between the bottom layers and normal layers. The more the transition layers are, the longer the time transition costs.

Settings

- **Step [0]:** The stage when printing platform is moving near the curing face. The speed of this stage is relatively slow to avoid affecting the printing.
- **Step [1]:** The stage that printing platform is moving away from the curing face. The speed of this stage is relatively fast to shorten the printing time.

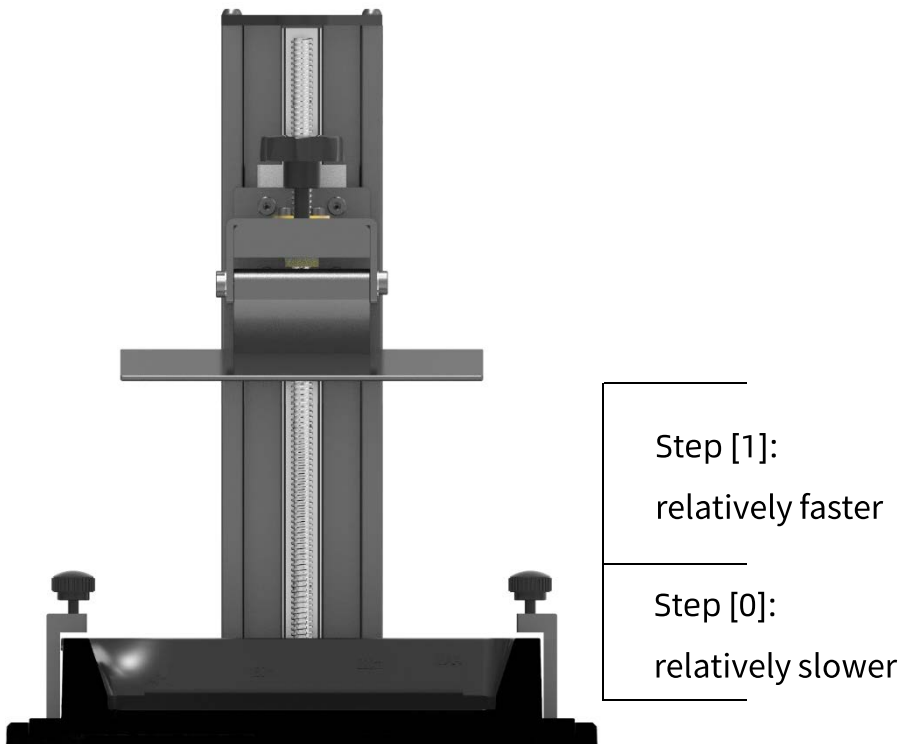

*Each Z lift height in Step[0] and Step[1] corresponds to distance of two printing platform's motion.

Settings

4. Web Printer (for Anycubic Photon M3 Plus only)

① Log in Anycubic Cloud.



Click to enter in log in interface

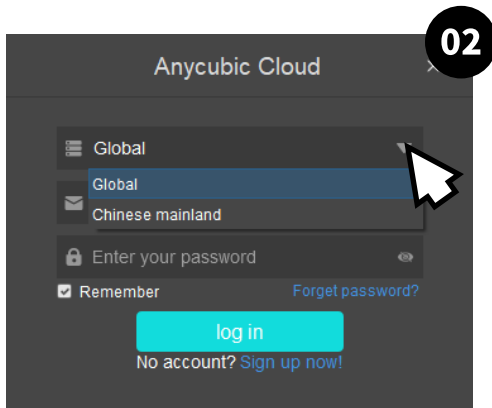

Select the global server

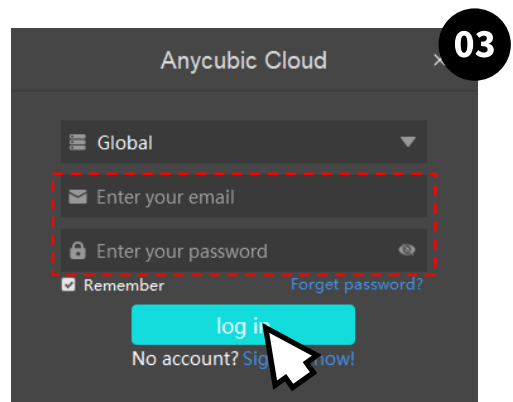

Enter your email and password then click log in

② Add printer.

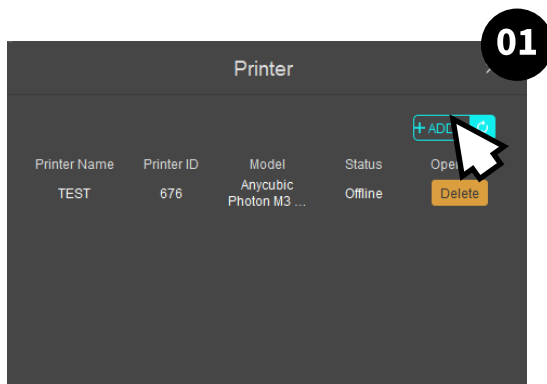

Click to add



Enter **device CN*** and printer name then click OK

*Device CN can be found in Cloud interface on the touch screen of Anycubic Photon M3 Plus.

1. View Changing

- **Mouse:** Scroll the mouse wheel to zoom in/out; left click the platform and drag to move it; right click the platform and move to change view angle.
- **Interface controls:** click the arrow to change view angle.

2. Model Changing



click “move” icon, input a number or manipulate the controls can move the model. You also can center or reset the model.

click “rotate” icon, input a number or manipulate the controls can rotate the model. You also can reset the model.

click “scale” icon, input a number or percentage or manipulate the controls can scale the model. You also can set the model to its maximum size.

click “mirror” icon, you can mirror the model in X, Y or Z direction.

click “layout” icon, you can duplicate the model and arrange the models in X or Y direction.

Notice: The dark grey part out of the print range is not printable.

3. Hollow and Infill

Hollow and infill the model to reduce resin consumption.

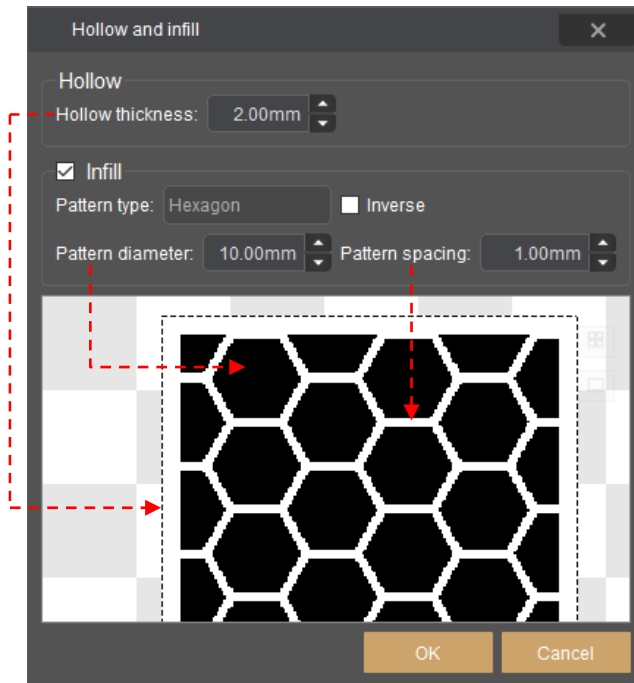

Please set the parameters according to your requirement. The following examples are for reference.

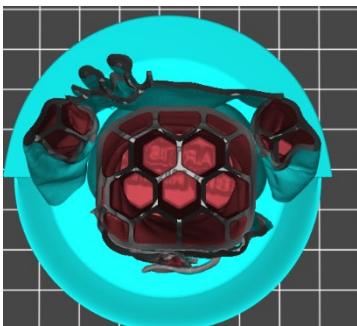

Hollow thickness: 1mm
infill

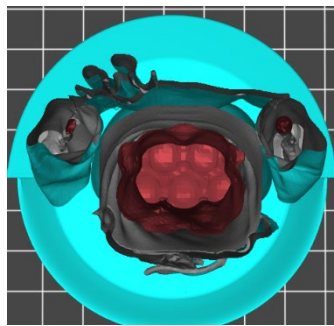

Hollow thickness: 3mm
infill

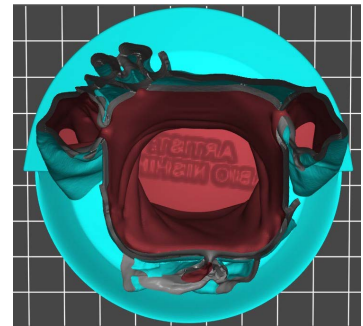

Hollow thickness: 2mm
no infill

The model name: MIA

The author of the model: Fabio Nishikata

4. Punching

If the model is hollowed, it is suggested to pinch on the side of the model to avoid the print failure caused by vacuum seal drawing. When the print is finished, that discharge the resin inside the model can prevent model being broken after a period of time.

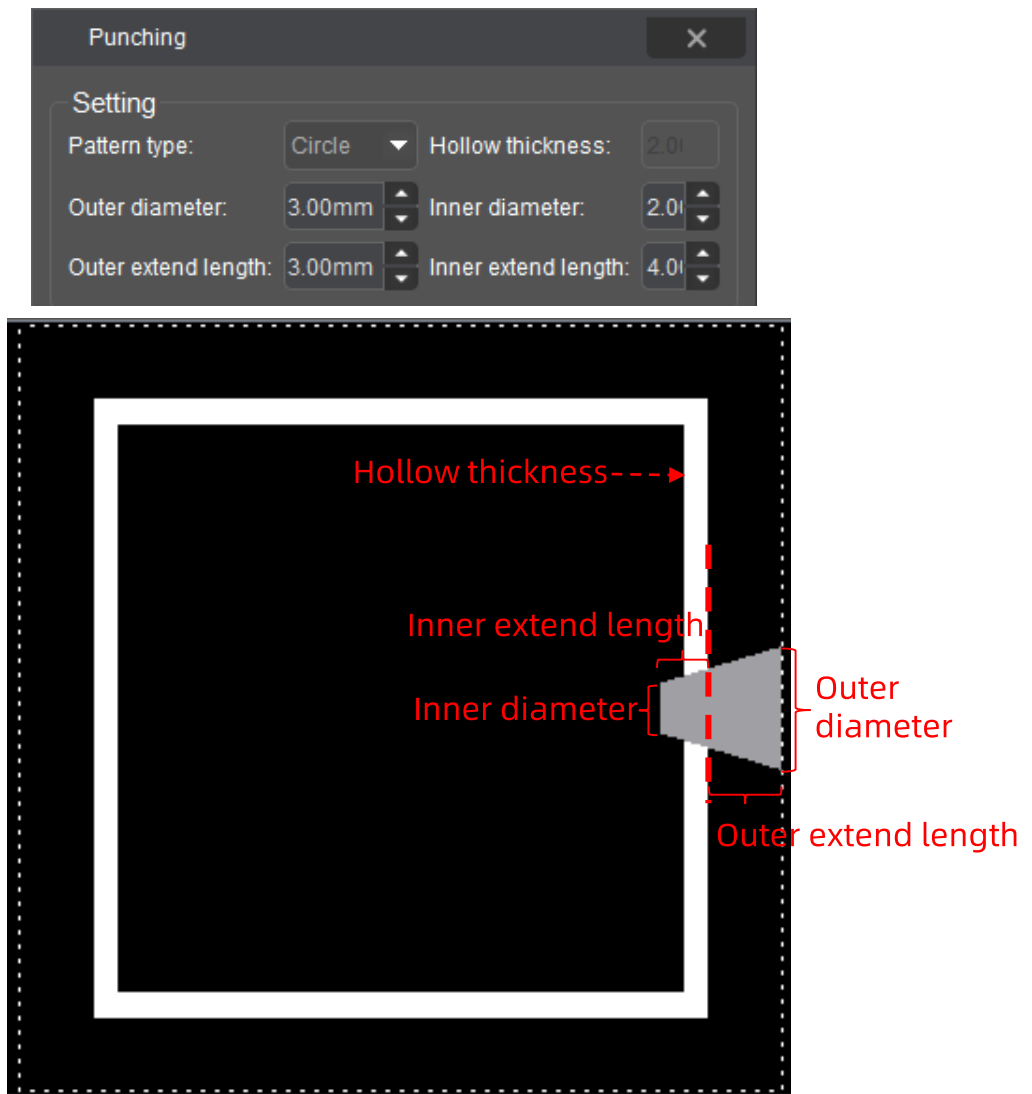

- ① First, set the parameters. "Inner extend length" must be larger than "Hollow thickness", so that the model can be pierced.
- ② When setting is finished, click on the model to pinch.
- ③ Click "OK" to finish.

Introduction to Functions

5. Text Paste

- Add mode

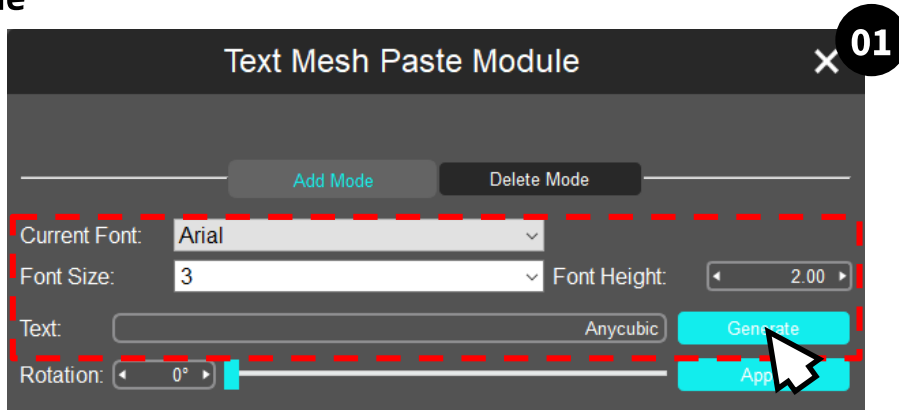

Set the text style and input the text then click generate

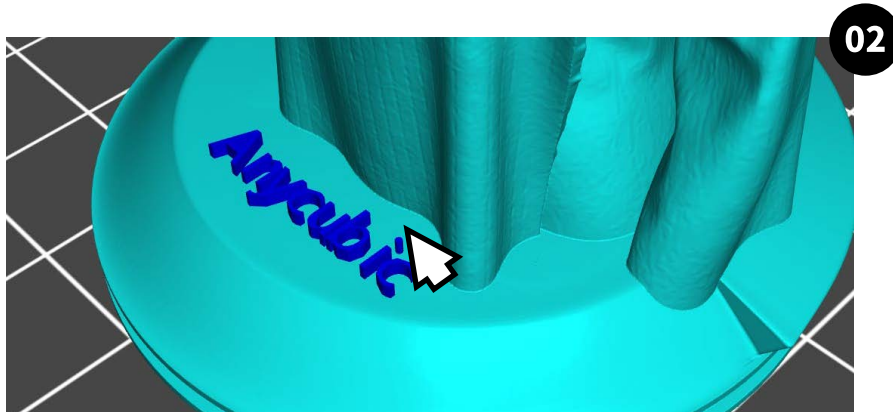

Click on a place to add text

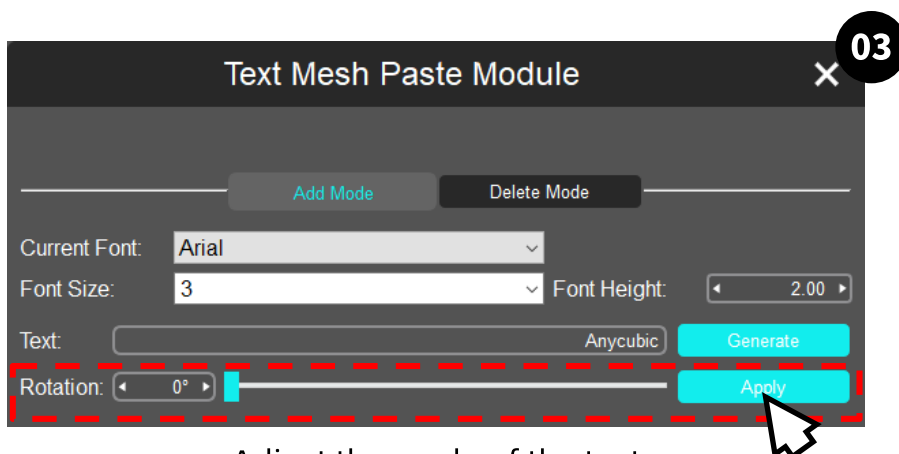

Adjust the angle of the text then click apply

Introduction to Functions

- Delete mode

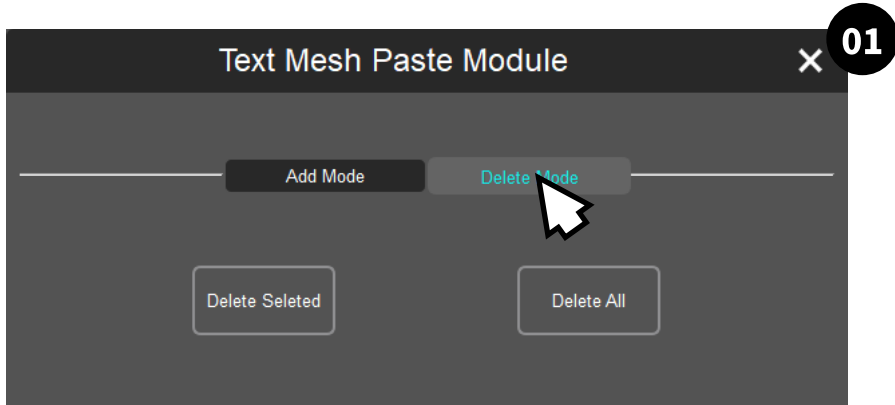

Switch to the delete mode

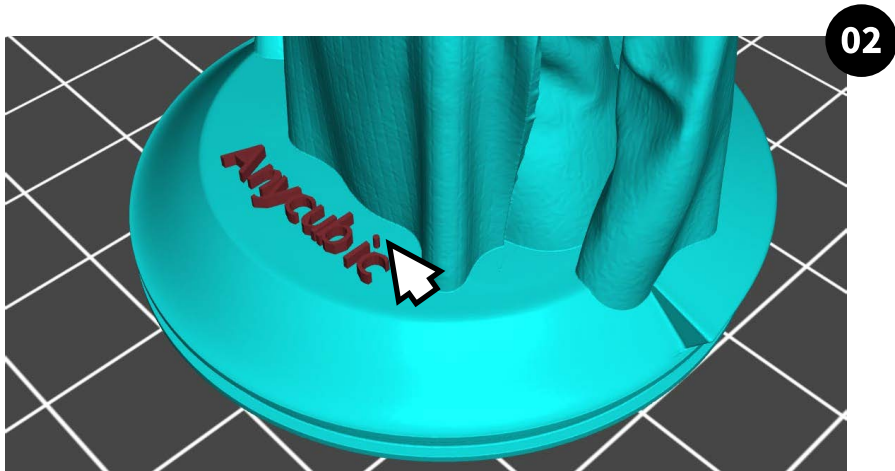

Click to select the text

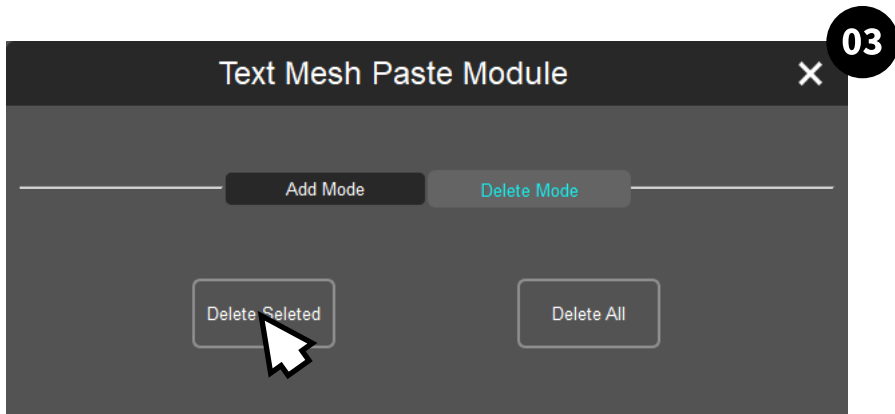

click delete selected to delete it

6. Split Model

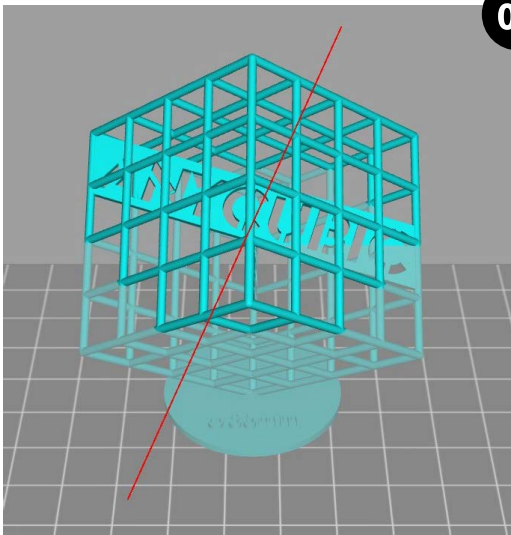

01

default split facet is horizontal
drag cross the model to redraw

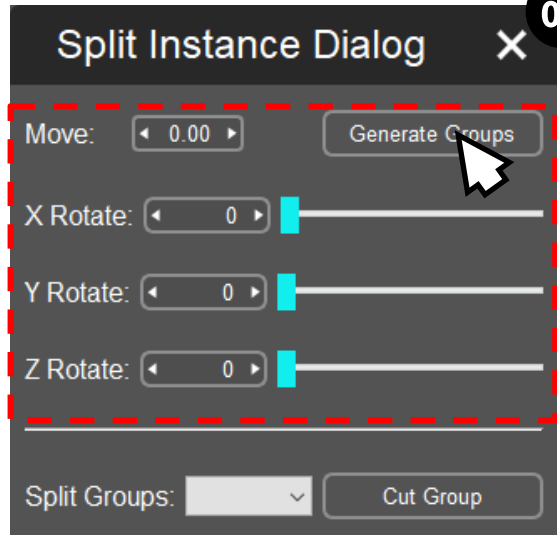

02

Adjust the split facet
then click generate groups

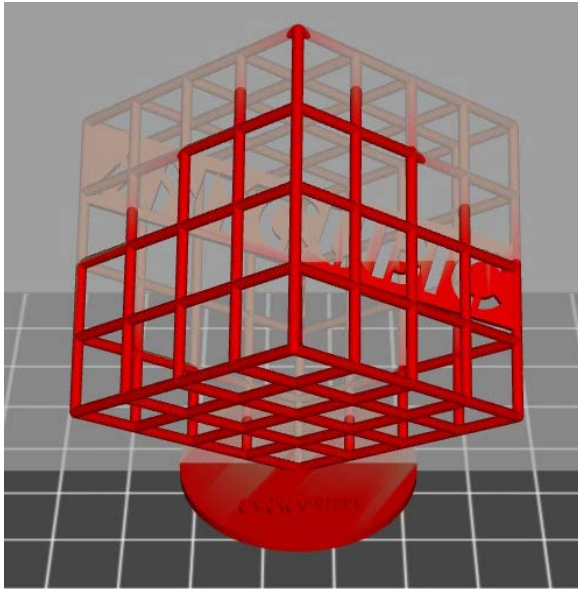

03

Select the split groups, the selected groups are red
Then click cut group to finish the splitting

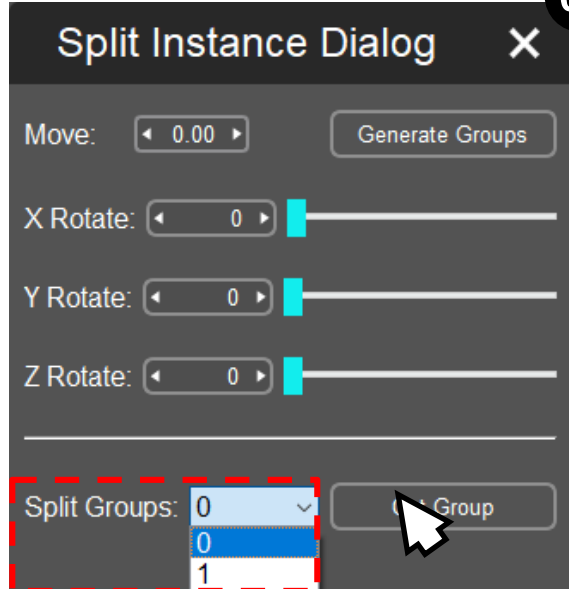

Introduction to Functions

7. 3D Face Reconstruction

It is the function reconstructing a face from 2D pictures into a 3D form.

① Upload the proper photos according to the requirements below:

- **Environment:** The light should be even and balanced to avoid shadows on the face. The facial contour should be clearly visible.
- **Background:** The background of the photo should be single color. The dark background is better. (black>blue>red>white)
- **Dimensions:** Minimum acceptable dimensions are 84 pixels (width) ×112 pixels (height)
- **Facial Requirements:** Please present the front and side views with the entire head and face clearly visible. The facial expression should look natural with eyes open and mouth closed. Do not let eyeglasses, hat or other object obscure the facial features.
- **Note:** The side views should show the point between the eyebrows.

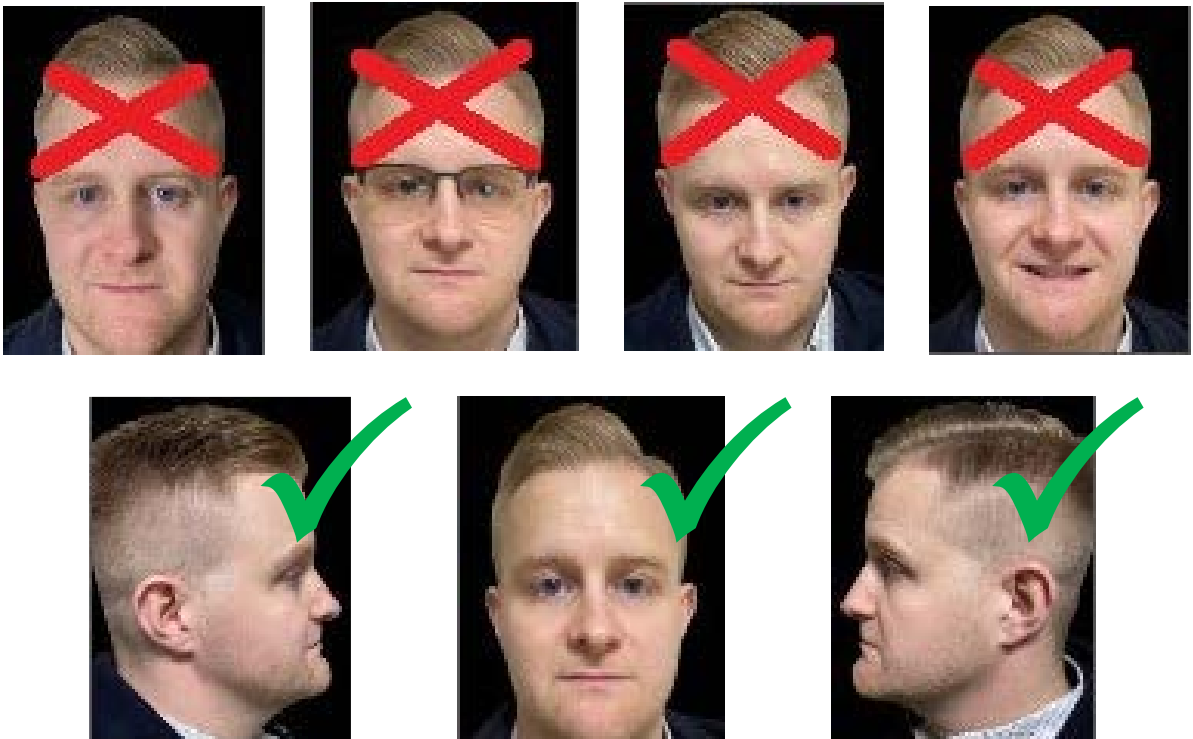

Introduction to Functions

② Click the corresponding points in accordance with the illustration and prompt to finish localization.

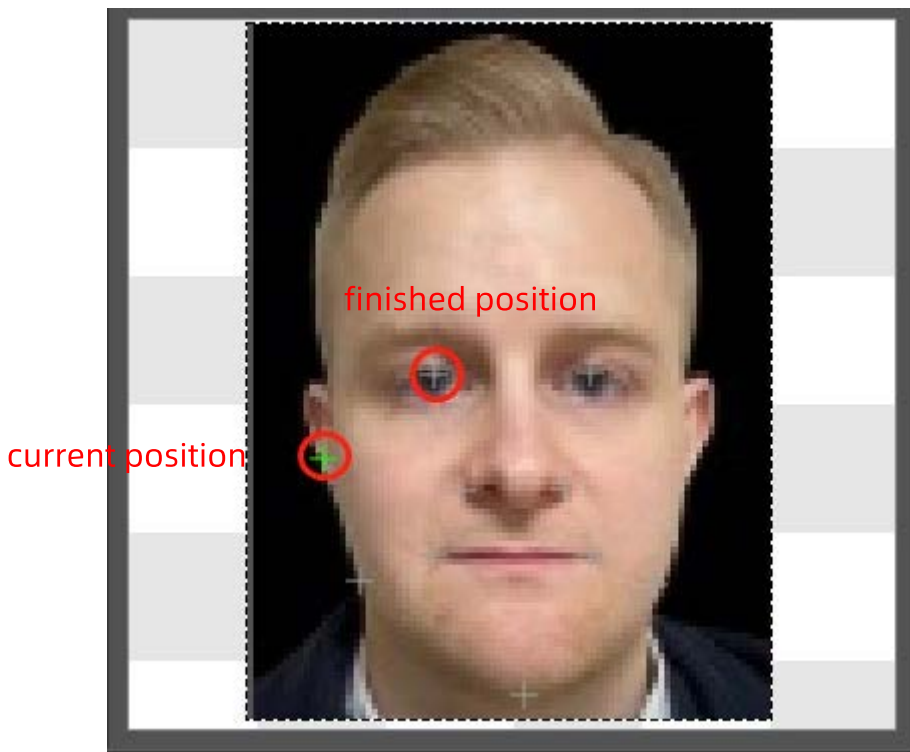

finished position is grey; current position is green
If you make a mistake, click the green cross to cancel.

③ When the steps are finished, click "Next" to reconstruct the face.

Support Settings

When the model has obvious suspended parts or overhang, it needs to add support to reduce the risk of printing failure.

1. Shape Editing

There are three types of support: light, medium and heavy.

Light: Contact area between the support and model is small, and the support is easy to remove.

Heavy: Support contact with the model area is large and solid.

It is recommended to try the "Medium" first, and use the default settings. Also, you can modify the support settings to fit your requirement.

- **Top**

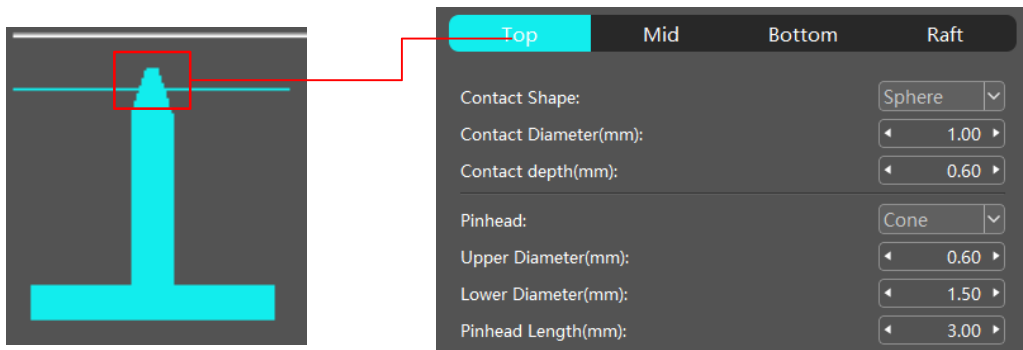

Contact Shape: Select the "Sphere" as the contact point can increase the contact area between the support and the model.

Contact Diameter: The larger the diameter, the larger the contact area between the support and the model.

Contact Depth: The contact depth between the support tip and the model. An appropriate connection length can ensure that the support top is rough enough and easier to remove.

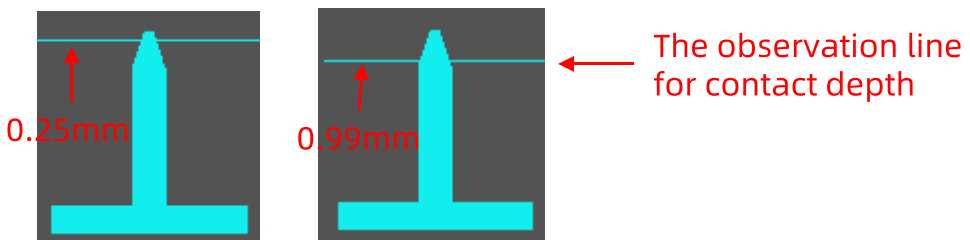

Support Settings

- **Mid**

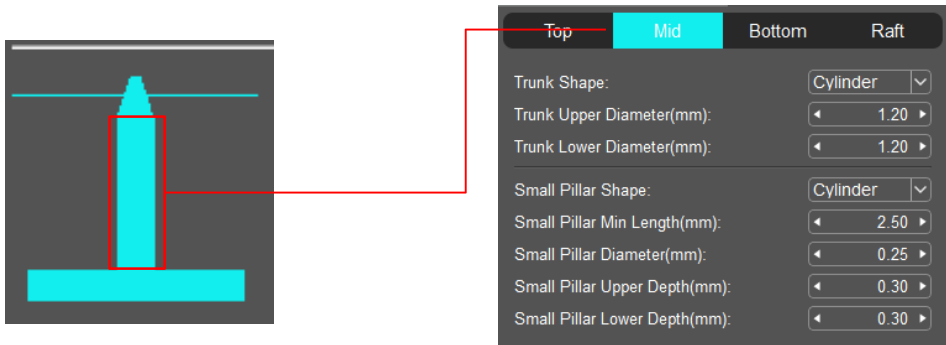

Shape: There are three options: "Cube", "Cylinder" and "Prism".

Diameter: The mid diameter must be larger than top diameter.

Small Pillar: If the distance between the point that needs to be supported and the model is too short, a small pillar will be generated.

Min Length: The minimum length of the small pillar.

Depth: The depth support embedding in the model.

- **Bottom**

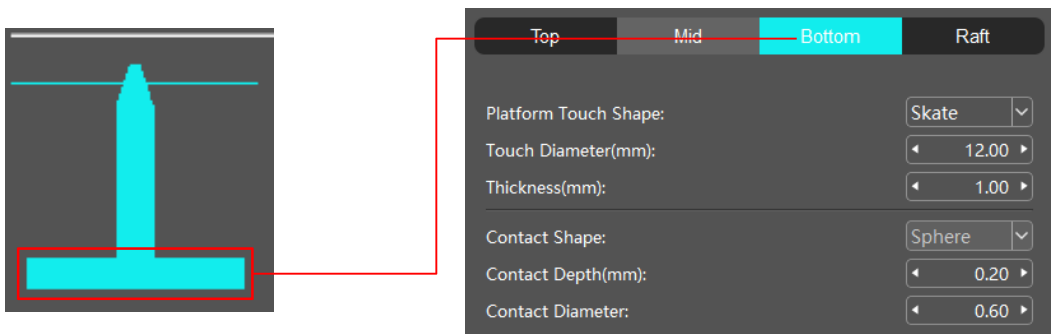

Platform Touch Shape: It is recommended to choose skate as bottom, which is easier to be removed from platform.

Touch Diameter: The diameter of the supports on the platform.

Contact Shape/Contact Diameter/Contact Depth : The bottom shape/diameter/depth of supports on the inside or outside surface of model.

- **Raft**

Raft will increase the adhesion between model and the print platform to reduce the risk of print failure.

Support Settings

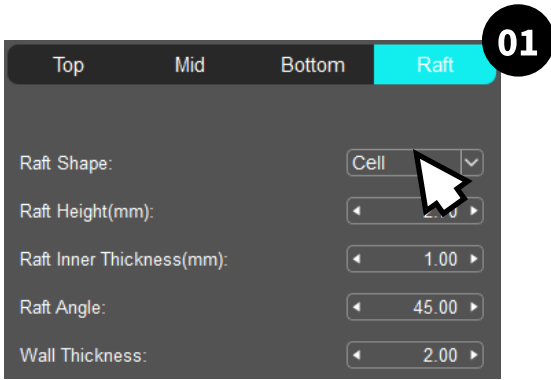

Select the shape of the raft as Cell or Outline

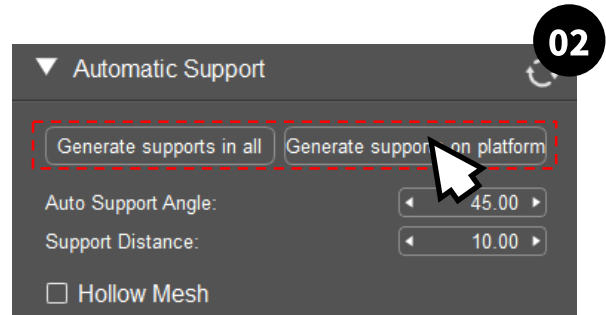

Generate automatic support to add the raft and support

Note: Before adding the raft, please raise the model by a certain height.

• Advanced

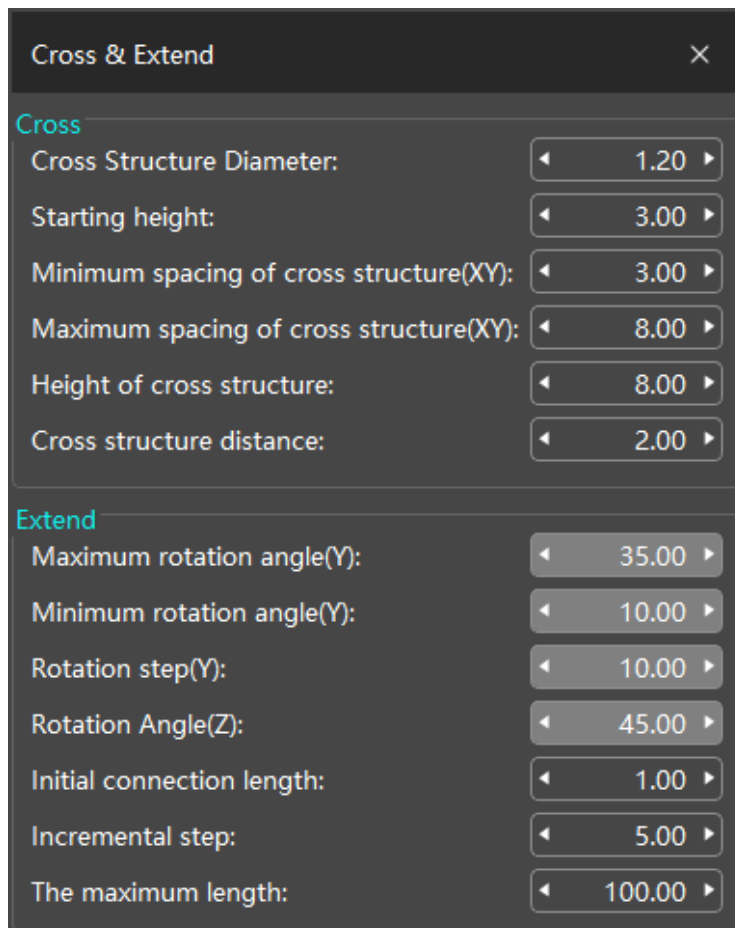

Support Settings

Cross: Horizontal cross structure is to strengthen supports.

Starting height: Cross is generated from a certain height.

Minimum/ maximum spacing: When the distance between two supports is short than the minimum spacing or longer than maximum spacing, cross will not be generated.

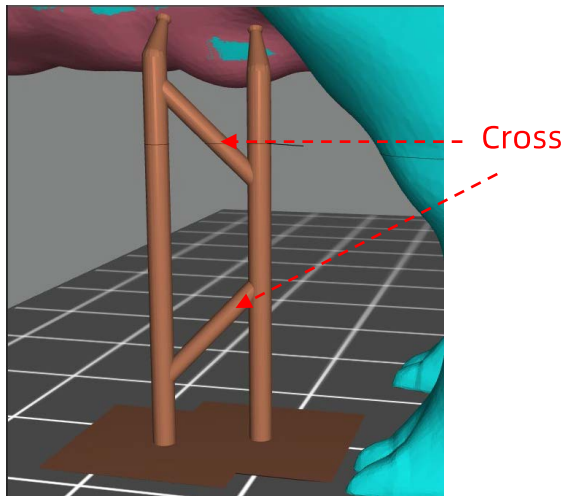

Extend: The extended part between support main part and top part.

Initial connection length: The minimum length of extended part.

Incremental length: The incremental length of extended part.

The maximum length: If the distance between start point of extended part and edge of model is longer than the maximum length, there will not generate extended part and this support will be added on model.

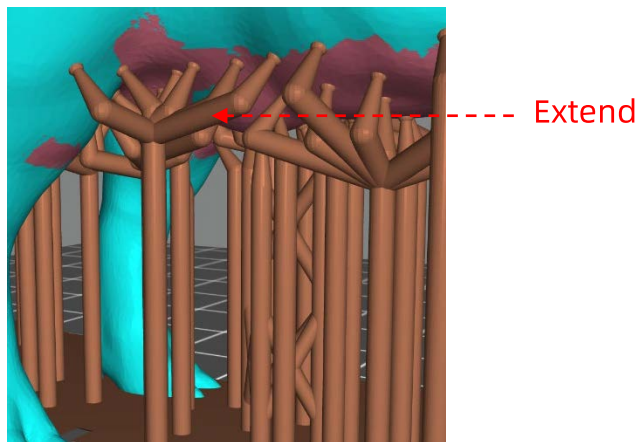

The author of the model: ZenMaster_Maker

Support Settings

2. Support Adding

You can add the support to the model manually or automatically after setting up the shape of the support.

- **Manual Support**

Add: Click the point on model which is needed support to add support.

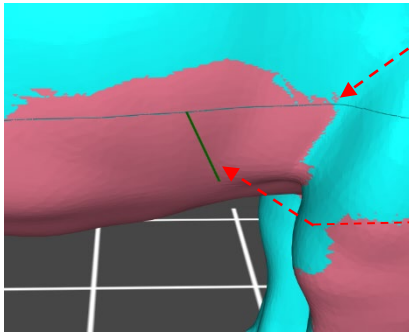

----- contour line, it can be used as reference when you add supports

The green short line can be clicked to add support; the red short line means the position cannot be added support.

Delete:

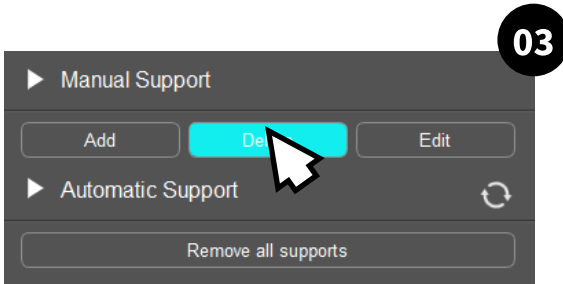
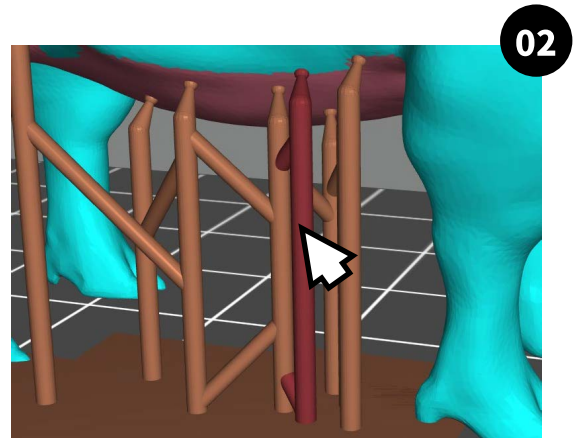
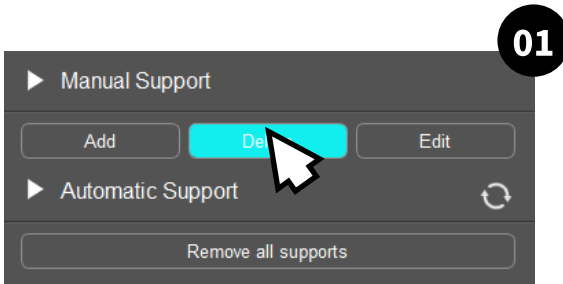

The author of the model: ZenMaster_Maker

Edit: Switch to edit mode and click to select a part of the support. Then, drag to modify its position.

Support Settings

- **Automatic Support**

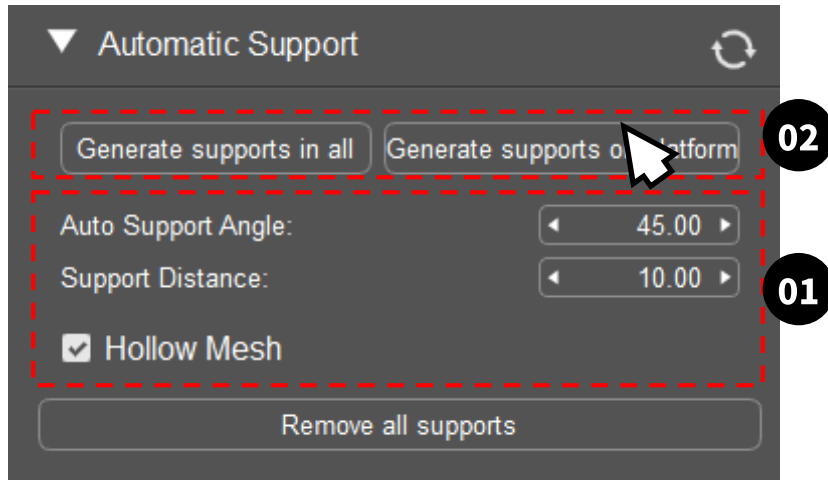

①Set auto support angle, support distance and whether add supports on hollowed part.

②Click “Generate supports in all” or “Generate supports on platform”.

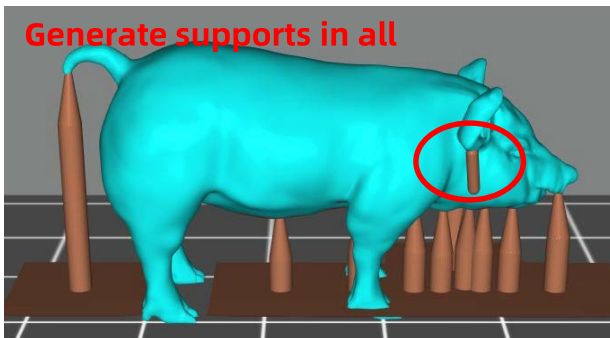

add between platform and model,
between points on model

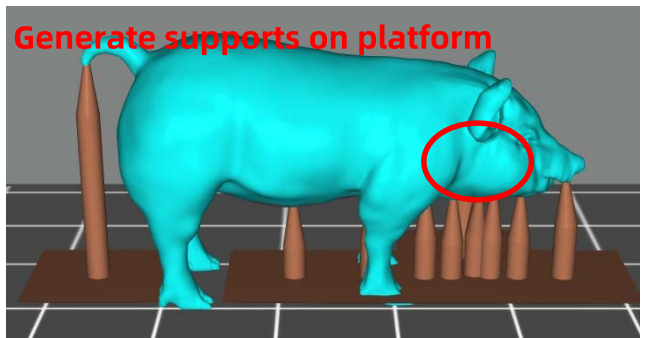

add between platform and model only

3. Automatic support adding skills

- **Properly increase support angle or decrease support distance**

When browsing on the model, by observing the contour circle, it can be found that the model still has some weak points that have not been added supports properly. If you increase support angle or decrease support distance, more supports can be added to some of the weak points.

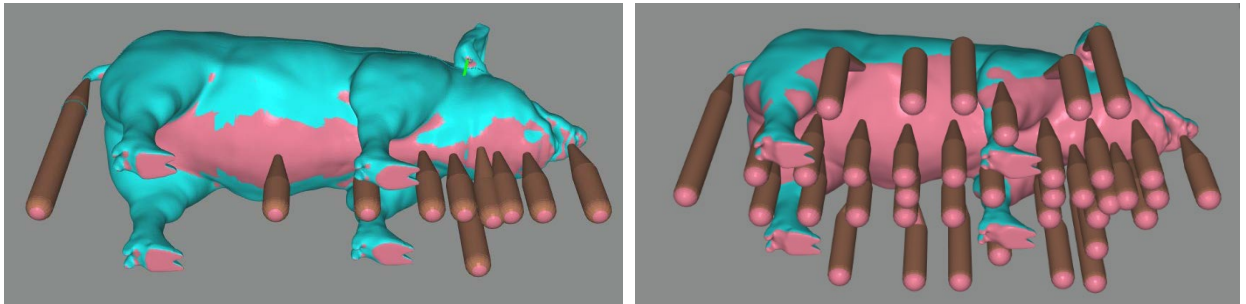

- **Add manual support after automatic support**

Add support to the local lowest point by checking the contour circle.

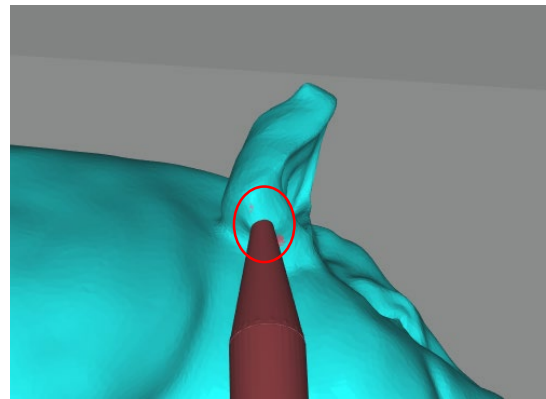
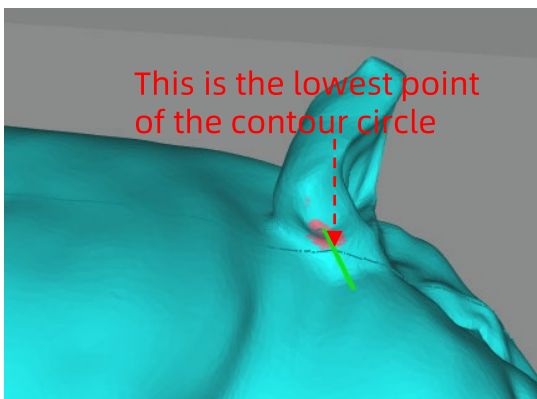

Add support manually

- **Check Land**

It checks whether model remains suspending parts after slicing. Click "Advanced"→"Check Land" in slice file preview interface, then drag slider to check the image of every layer.

Support Settings

The green part means there is support below; the yellow part is connected to other parts but may be suspended and may need supports; the red part is completely suspended and must be added supports.

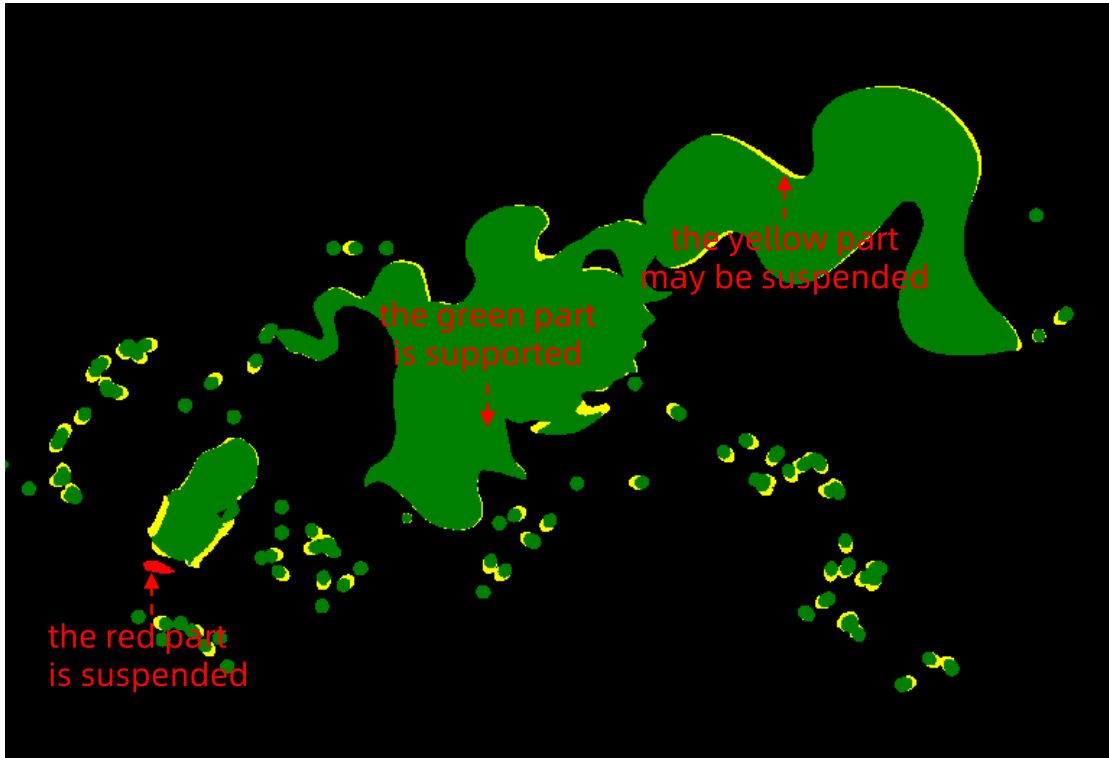

Export Sliced File

1. Slice

When the setting is finished, click Slice. **Anycubic 3D printer can only read its corresponding sliced file formats, please choose the machine type you use at Machine Settings to ensure higher printing success rate.**

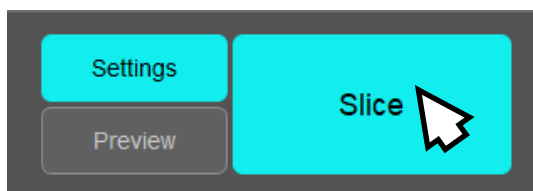

2. Preview

In the slice file view interface, you can preview slice settings. If necessary, you can adjust the slice settings; or check to enable layer settings and set the parameters.

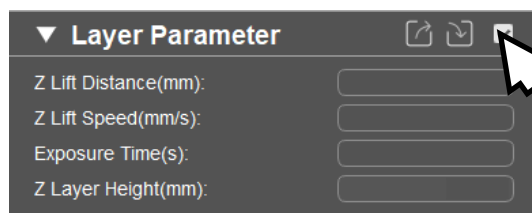
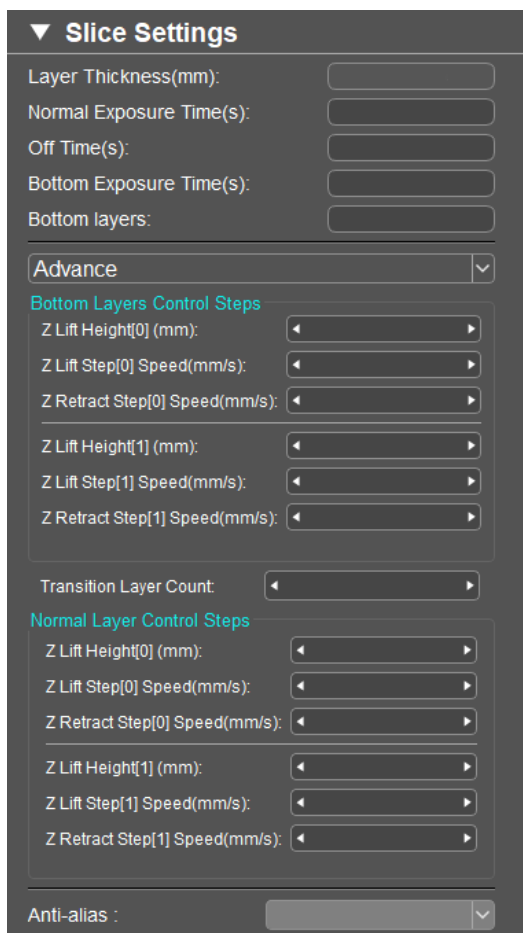

Check to enable

Notice: When layer parameter is set, the parameters of the new file cannot be modified via the printer touch screen during printing. Even if it has been modified, the setting would only be valid for the next layer.

view or modify slice parameters

Export Sliced File

3. Export

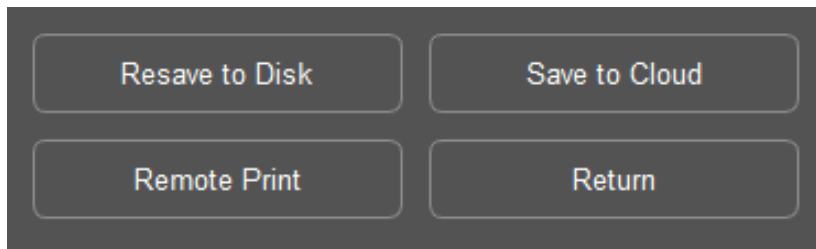

- **Save to Disk:** Resave the slice file after modify the parameters.
- **Save to Cloud:** Save the slice file to Anycubic Cloud.
- **Remote Print:** Send the slice file to the printer and start printing. This print job can also be control remotely by Anycubic Cloud.
- **Return:** If some other manipulations of model are needed, click “Return” and go back to editing interface.