

FERMENTAP

Stainless Weldless Sight Gauge

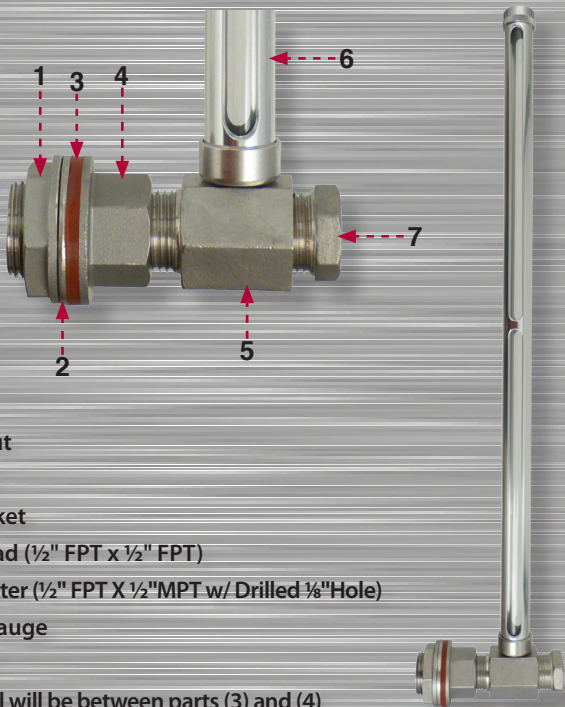

Kit Includes:

- 1) Stainless Lock Nut
- 2) Stainless Washer
- 3) Red Silicone Gasket
- 4) Stainless Bulkhead (1/2" FPT x 1/2" FPT)
- 5) Sight Gauge Adapter (1/2" FPT X 1/2" MPT w/ Drilled 1/8" Hole)
- 6) Stainless Sight Gauge
- 7) Stainless Plug 1/2"

Note: Your kettle wall will be between parts (3) and (4)

Installation Instructions:

1. Determine where you'd like to install your Sight Gauge and mark the spot with a pen (keep in mind the final diameter of the hole will be 1").



**ALWAYS WEAR PROTECTIVE SAFETY
GLASSES WHEN DRILLING METAL**



2. Secure your kettle and drill a pilot hole with a ¼" drill bit. Next change to a step drill bit to gradually enlarge your pilot hole to the final necessary diameter of 1".

a. If step drill bit stops/gets stuck, apply light downward force with a high rpm to start your hole again.

b. As you get closer to the 1" size hole, check to see if your bulkhead (4) makes it through with each additional step.

Note: make sure to use the wider side of the bulk head when checking the hole size.

3. Unscrew the sight gauge (6) from Adapter (5). Next unscrew the Lock Nut (1) from Bulkhead (4) and remove Stainless Washer (2) and Red Gasket (3).

4. Insert the larger threaded side of the bulkhead (4) through the hole in your kettle from the outside.

5. Replace the Red Gasket (3), then the Stainless Washer (2), and then thread the Lock Nut (1) back on, using wrenches or channel locks to tighten until snug. Then thread the Sight Gauge (6) back into Adapter (5).

6. Fill your vessel with water and test for leaks before you use it. Tighten down further on the Lock Nut (1) and Bulkhead (4) body if necessary.