

August Literacy Activities

FIRST GRADE SKILLS & STANDARDS



6 Centers • 6 Worksheets • Decodable Reader

August Literacy Activities

What's Included in this Resource

- 1 6 Center Activities (with recording pages)
- 2 6 Sets of Worksheets
- 3 Decodable Reader with 3 levels
- 4 Decodable Passage (with comprehension questions)
- 5 Differentiated materials to meet the needs of all students

Everything you need to teach literacy skills in August!

August Literacy Activities

What's Included in this Resource

Scope & Sequence



6 Sets of Worksheets



6 Centers



Decodable Readers



Comprehension Passages



Differentiated materials for all activities!

AUGUST

Literacy Centers & Worksheets

Skills Covered:

Beginning Sounds

Color By Beginning Sound

Sentence Structure

Sentence Building
Sentence Practice

Onset-Rime

Puzzles

ABC Order

Task Cards

Ending Sounds

Ending Sound Find & Color

Spelling CVC Words

Crack The Code
Around The Room Scoot

Syllables

Sorting

Sight Words

Build The Sight Words

Medial Sounds

Clip Cards

Decoding CVC Words

Decodable Readers
Decodable Passage

Word Families

Matching

Rhyme Recognition

Rhyming Spin & Color

August Worksheets

Color By Beginning Sound

Kids will enjoy coloring these fun, mystery pictures that are revealed as they color. They will look at the picture and color each space to correspond to the beginning sound color key.

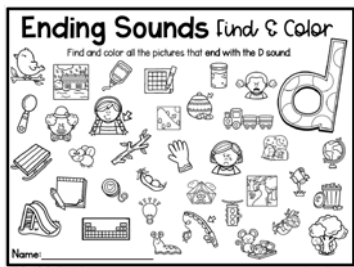
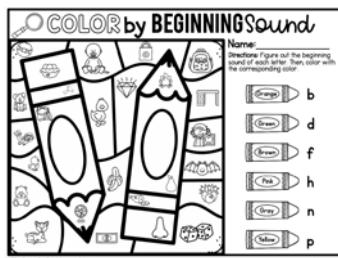

Ending Sound Find & Color

Use these worksheets to practice identifying and isolating the ending sound of words. Students will love looking through a page of fun pictures to find the ones that end in a specific sound!

Sentence Work

These worksheets provide two ways for kids to practice sentence structure: sentence building and sentence practice. For August, the focus is on capitalization and punctuation.

SENTENCE Building

Name: _____

Build your sentence.

Write your sentence.

Search & Find

1) Circle the capital letter at the beginning of your sentence.

2) Circle the punctuation at the end of your sentence.

Illustrate your sentence.

pencils | I | new

SENTENCE Practice

Name: _____

my friends are nice

we will learn

have nice pencils

it will be a great year



COLOR by BEGINNING Sound

Name: _____

Directions: Figure out the beginning sound of each letter. Then, color with the corresponding color.

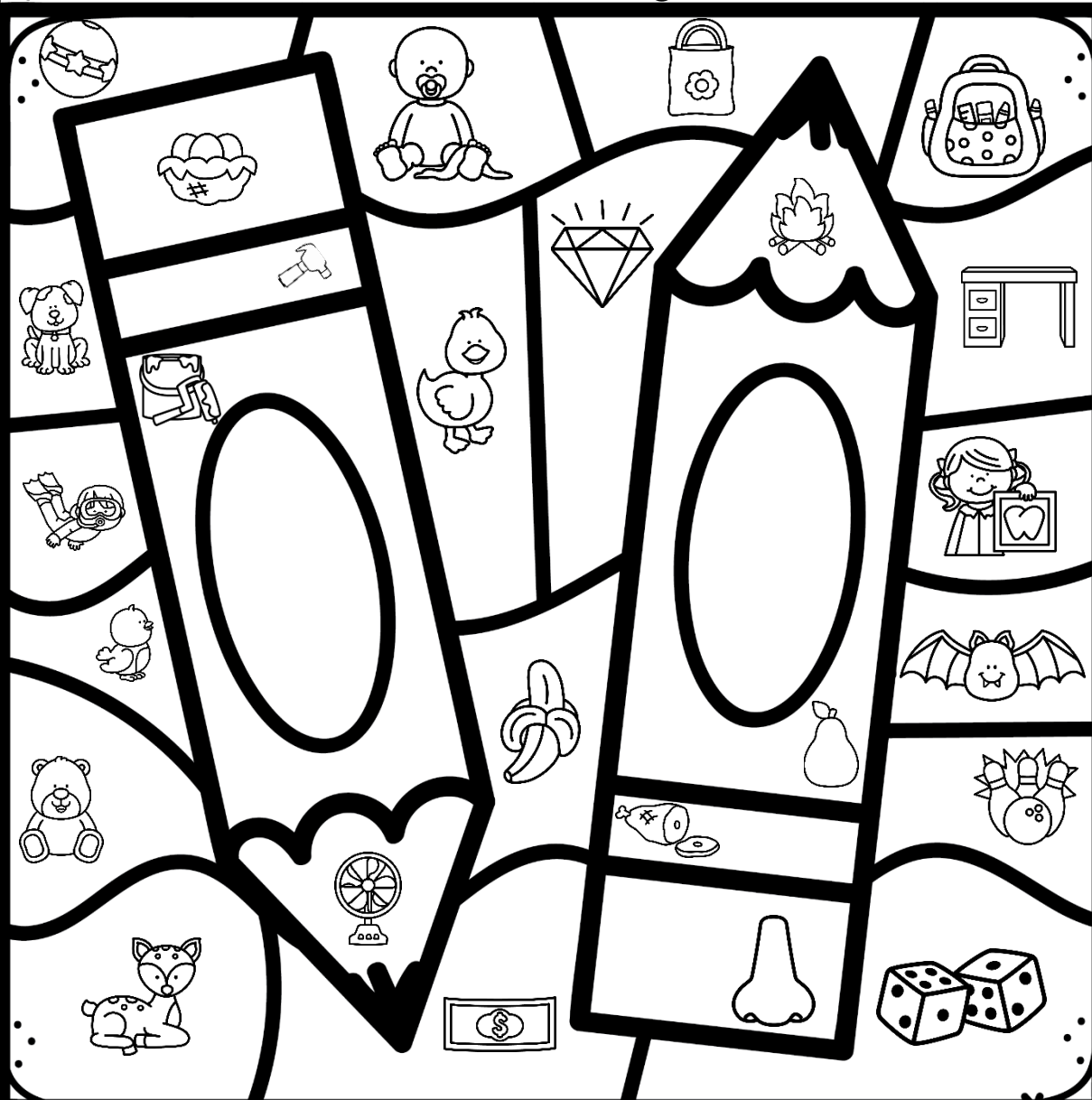

b



d



f



h



n



p



COLOR by BEGINNING Sound

Name: _____

Directions: Figure out the beginning sound of each letter. Then, color with the corresponding color.

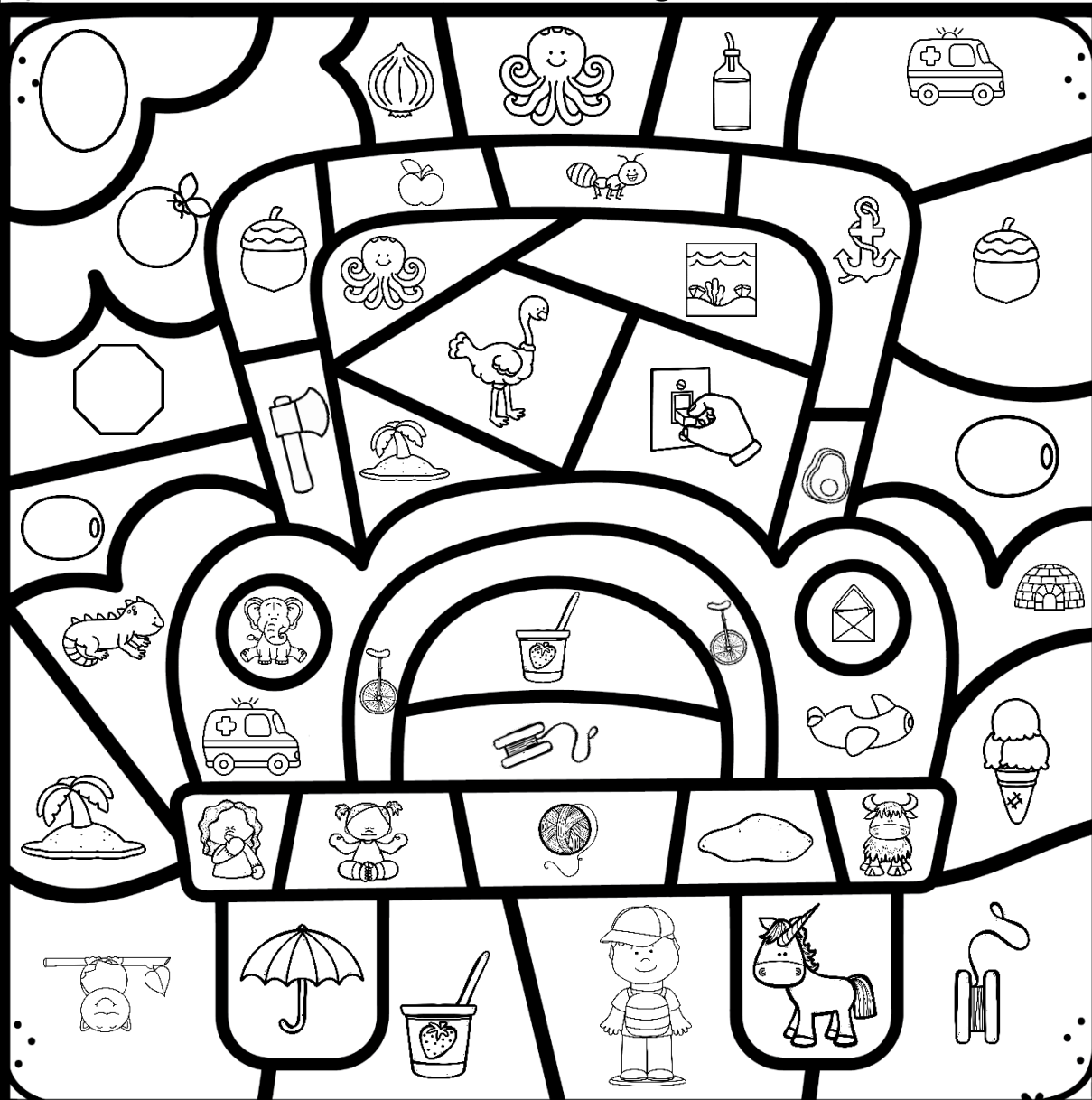

a



e



i



o

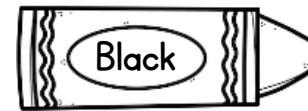

u



y



COLOR by BEGINNING Sound

Name: _____

Directions: Figure out the beginning sound of each letter. Then, color with the corresponding color.

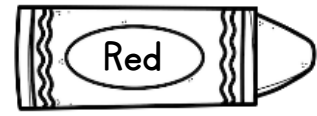
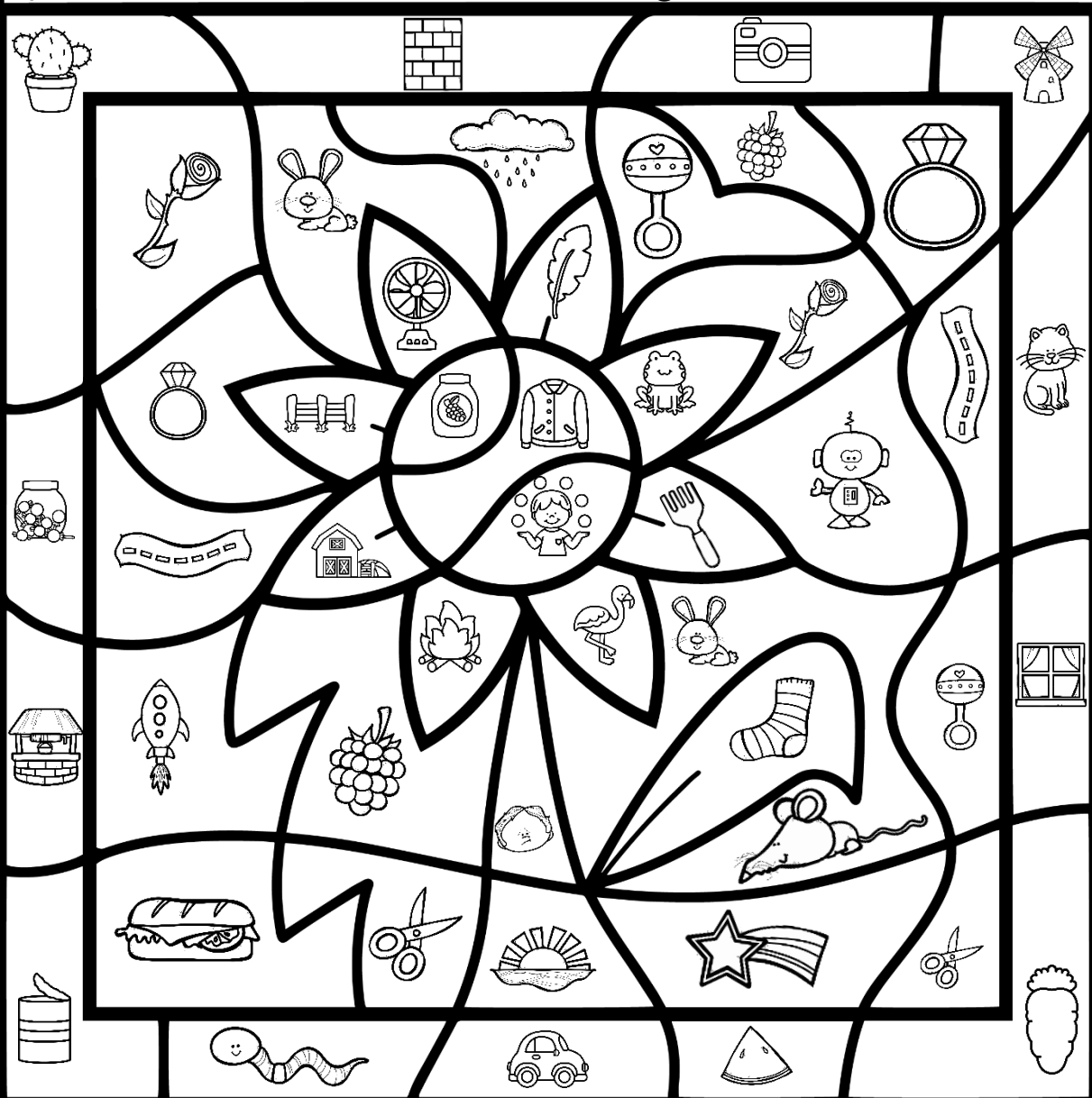

c

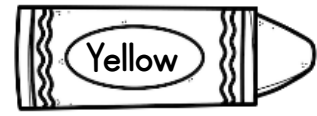

f

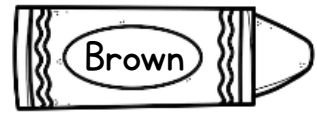

j

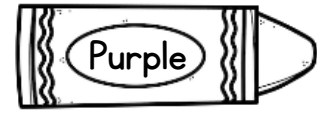

r

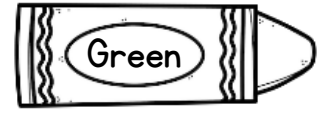

s



w

COLOR by **BEGINNING** Sound

Name: _____

Directions: Figure out the beginning sound of each letter. Then, color with the corresponding color.

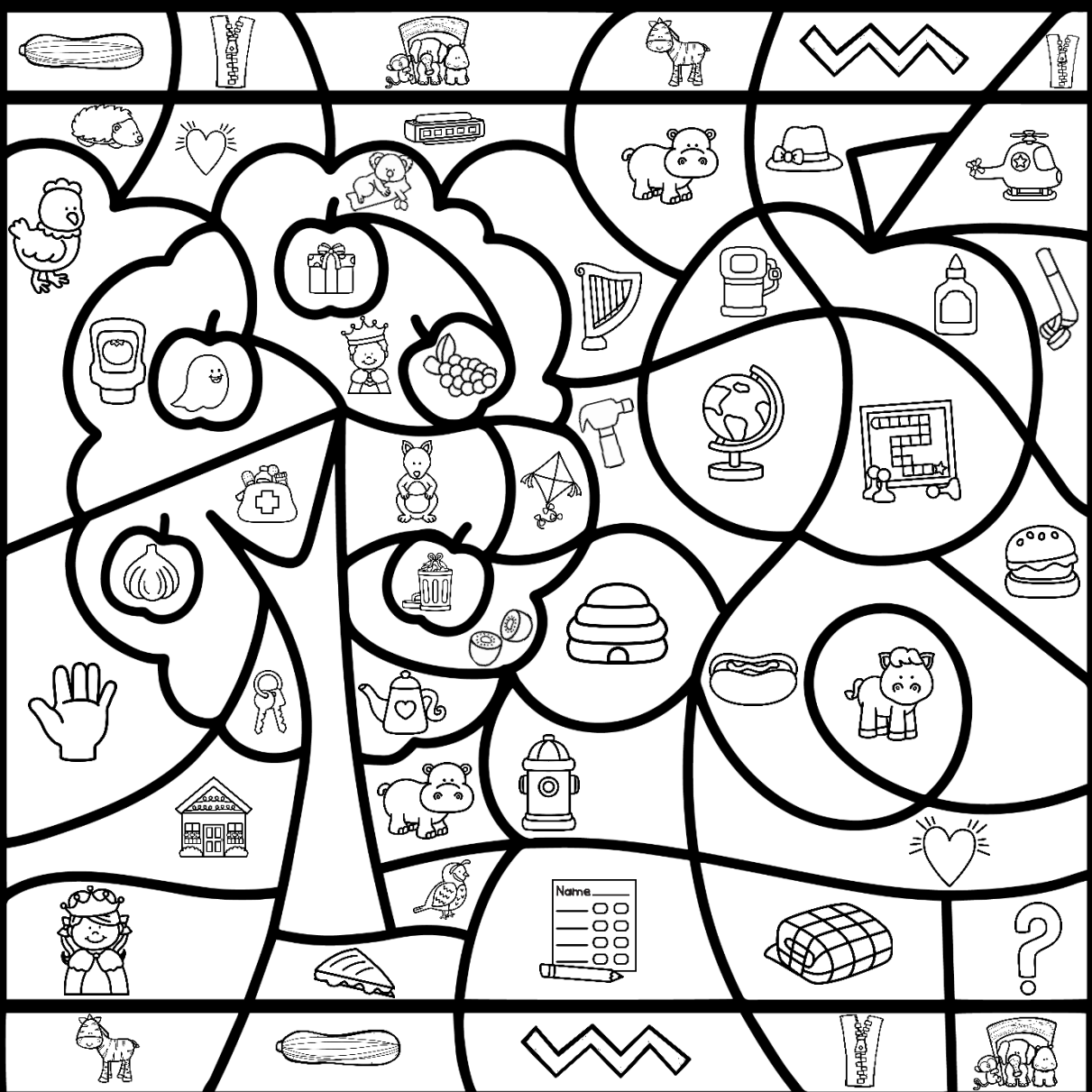

g



k



h



q



x



z



COLOR by BEGINNING Sound

Name: _____

Directions: Figure out the beginning sound of each letter. Then, color with the corresponding color.

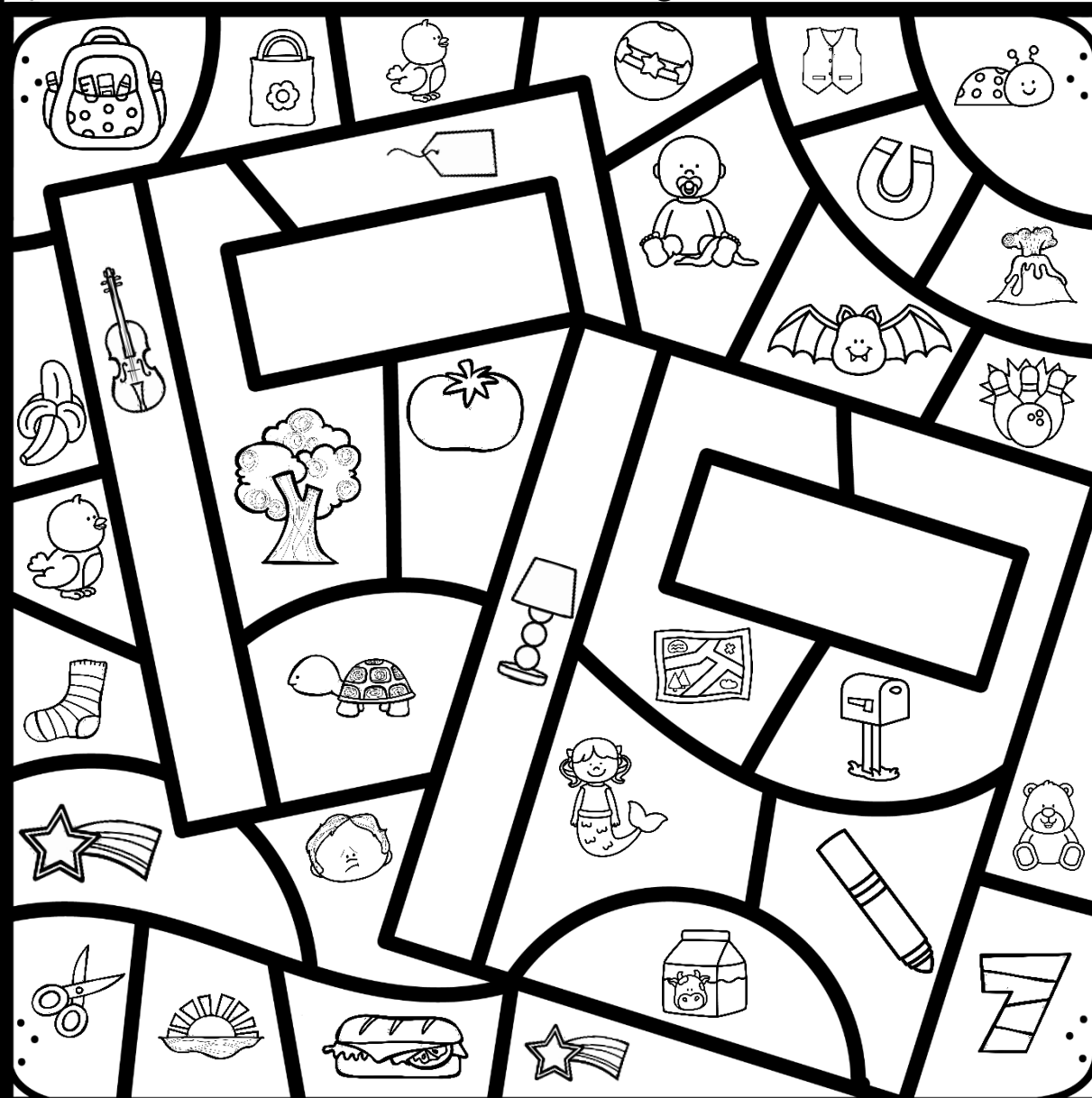

i



m



t



v

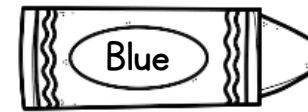

b

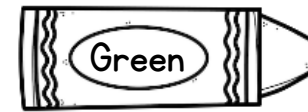

s

Ending Sounds Find & Color

Find and color all the pictures that end with the N sound.

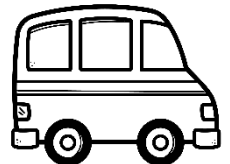
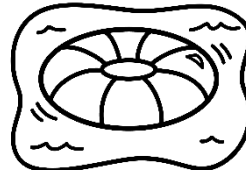
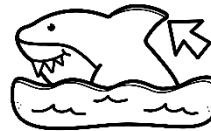
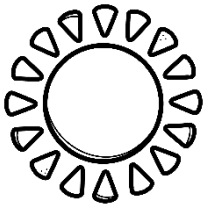
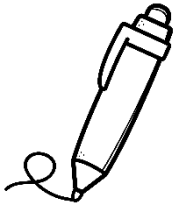
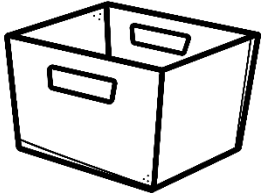
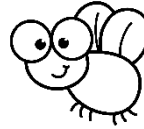
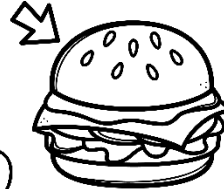
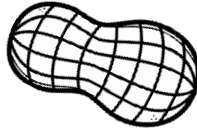
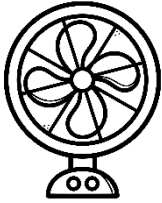
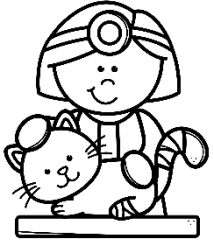
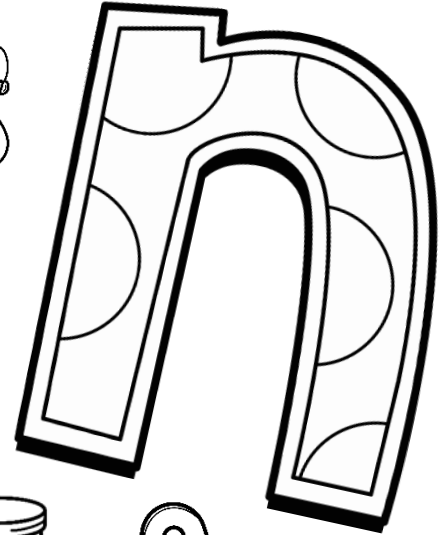
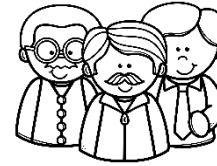
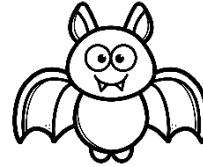

Name: _____

Ending Sounds Find & Color

Find and color all the pictures that end with the G sound.

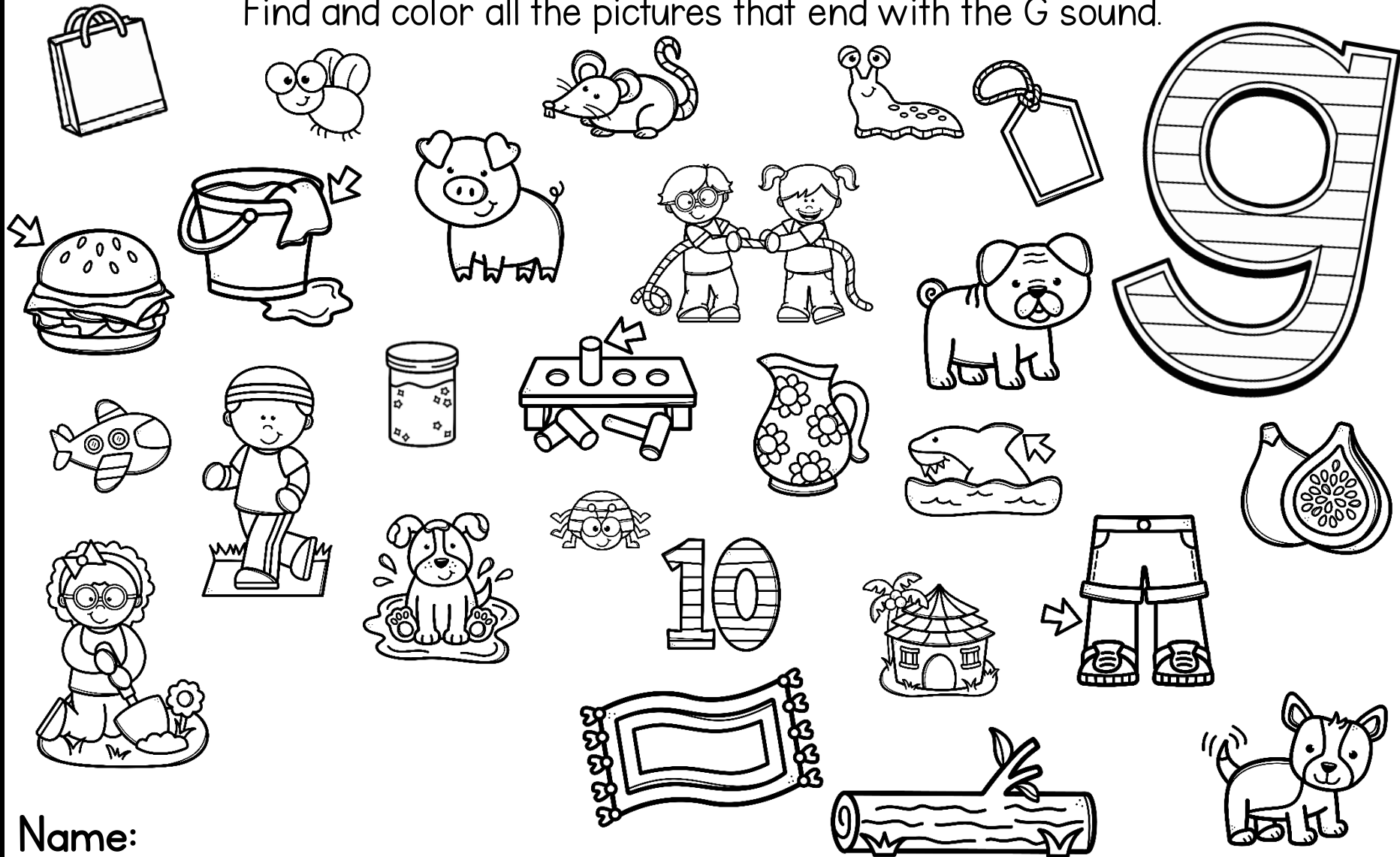

Name: _____

Ending Sounds Find & Color

Find and color all the pictures that end with the S sound.

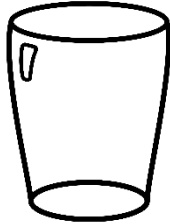
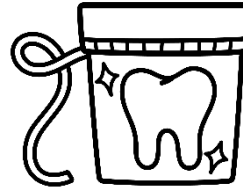
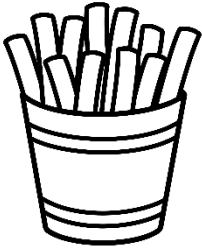
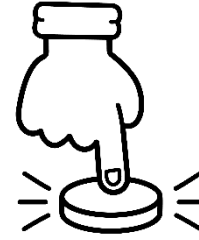
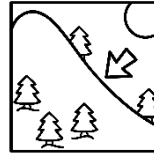
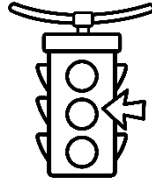
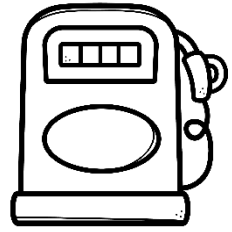

$$2 + 3 =$$

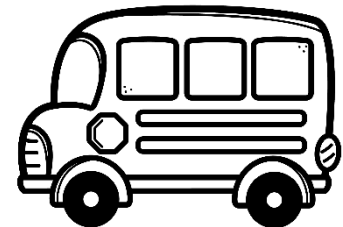
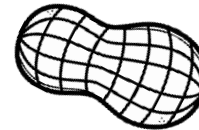
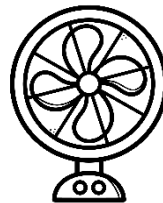
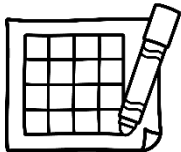
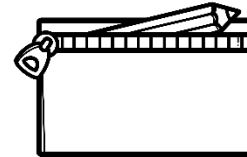
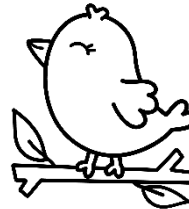
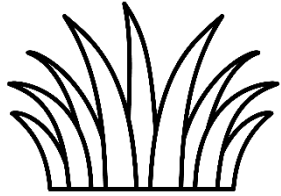
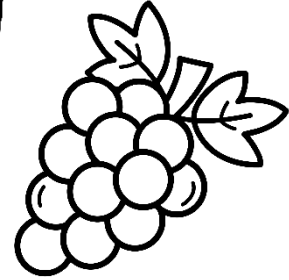

Name: _____

SENTENCE Building



Name: _____

Build your sentence.

Write your sentence.

Search & Find

- Circle the capital letter at the beginning of your sentence.
- Circle the punctuation at the end of your sentence.

Illustrate your sentence.

pencils

I

.

new

have

SENTENCE Building



Name: _____

Build your sentence.

Write your sentence.

Search & Find

- Circle the capital letter at the beginning of your sentence.

- Circle the punctuation at the end of your sentence.

Illustrate your sentence.

outside We . like to play

SENTENCE Building



Name: _____

Build your sentence.

Write your sentence.

Search & Find

- Circle the capital letter at the beginning of your sentence.

- Circle the punctuation at the end of your sentence.

Illustrate your sentence.

fun

My

.

teacher

is

SENTENCE Building



Name: _____

Build your sentence.

Write your sentence.

Search & Find

- Circle the capital letter at the beginning of your sentence.

- Circle the punctuation at the end of your sentence.

Illustrate your sentence.

is heavy . backpack My

SENTENCE Building



Name: _____

Build your sentence.

Write your sentence.

Search & Find

- Circle the capital letter at the beginning of your sentence.

- Circle the punctuation at the end of your sentence.

Illustrate your sentence.

can

We

.

read

books

SENTENCE Practice

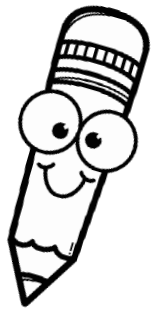

Name: _____

Directions: Rewrite each sentence so it starts with a capital letter and ends with the correct punctuation.

i like school

my friends are nice

we will learn

i have new pencils

it will be a great year

SENTENCE Practice



Name: _____

Directions: Rewrite each sentence so it starts with a capital letter and ends with punctuation.

my teacher is fun

i like gym class

we can play tag

she has chips for lunch

he wants to play outside

SENTENCE Practice



Name: _____

Directions: Rewrite each sentence so it starts with a capital letter and ends with punctuation.

we are in first grade

i love to learn

she is good at math

my pencil is sharp

he smiles at his friend

August Worksheets

Crack The Code

Kids will love using their Alphabet Code Chart to crack the code for the mystery words. The recording sheet is provided at three levels to support all students!

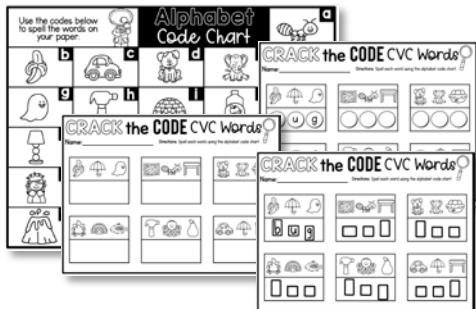

Rhyming Spin & Color

Kids will spin the spinner and find a word that rhymes with that word. Great for literacy centers, word work, or small groups. Multiple versions make differentiation a breeze!

Around The Room Scoot

Get students out of their chairs and moving around the room as they search for picture cards and practice spelling CVC words. Differentiated recording sheets are provided!

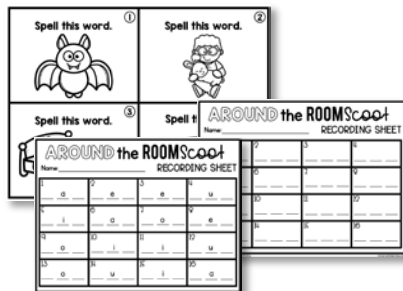

Use the codes below
to spell the words on
your paper.



Alphabet Code Chart



a



b



c



d

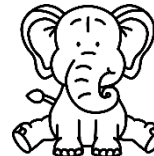

e

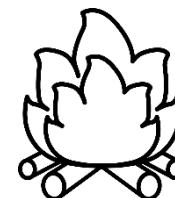

f



g

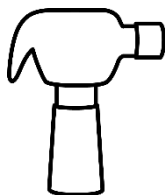

h

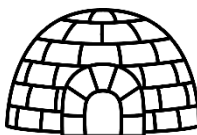

i



j

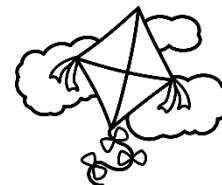

k

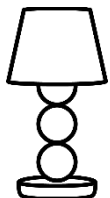

l

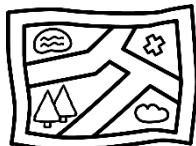

m

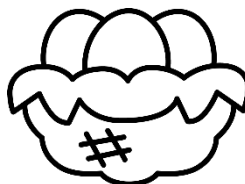

n

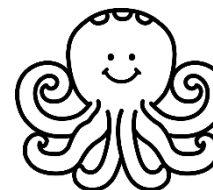

o



p



q



r



s

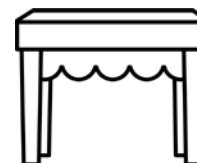

t



u



v



w



x



y

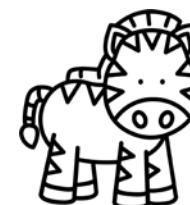



z



CRACK the CODE CVC Words





Name: _____

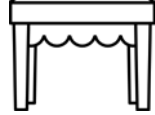

Directions: Spell each word using the alphabet code chart.

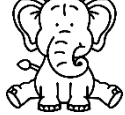

		
b	u	g

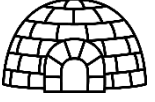
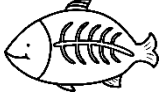

		



CRACK the CODE CVC Words







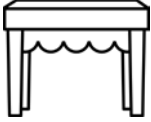

Name: _____



Directions: Spell each word using the alphabet code chart.



		
b	u	g

		

CRACK the CODE CVC Words

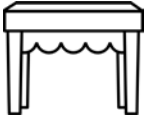

Name: _____

Directions: Spell each word using the alphabet code chart.





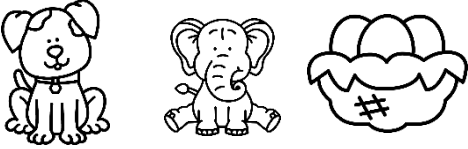

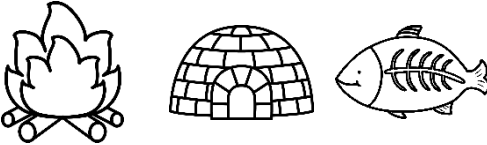

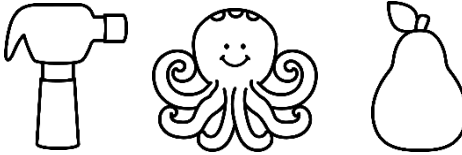









CRACK the CODE CVC Words



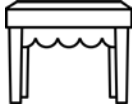



Name: _____



Directions: Spell each word using the alphabet code chart.

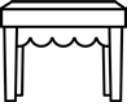

		
v	e	t

		

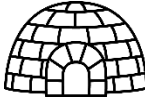

CRACK the CODE CVC Words





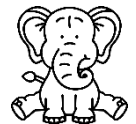
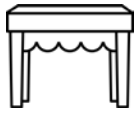

Name: _____

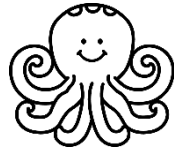
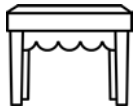

Directions: Spell each word using the alphabet code chart.



		
v	e	t

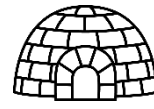

CRACK the CODE CVC Words



Name: _____

Directions: Spell each word using the alphabet code chart.

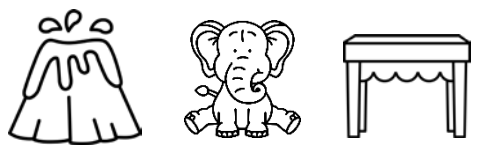

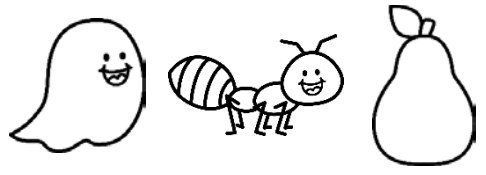

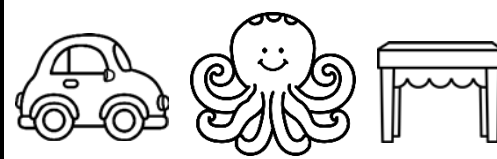

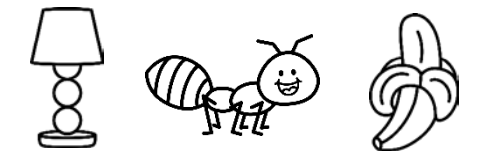

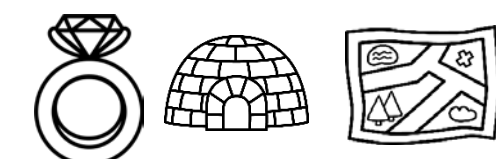









CRACK the CODE CVC Words





Name: _____



Directions: Spell each word using the alphabet code chart.

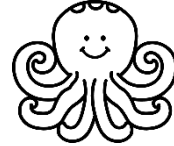

		
b	o	x

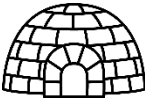
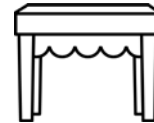

		

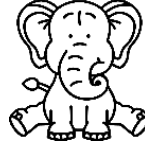

CRACK the CODE CVC Words



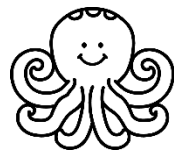



Name: _____



Directions: Spell each word using the alphabet code chart.



		
b	o	x

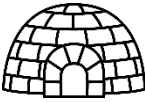
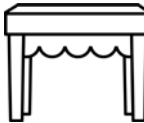

CRACK the CODE CVC Words

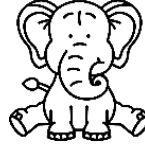

Name: _____

Directions: Spell each word using the alphabet code chart.

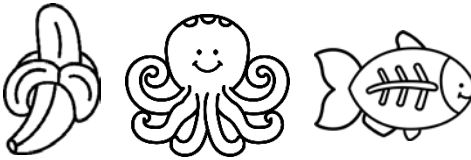





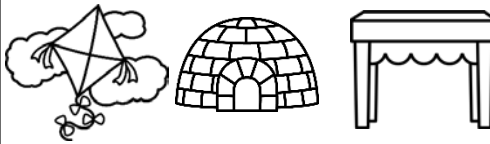

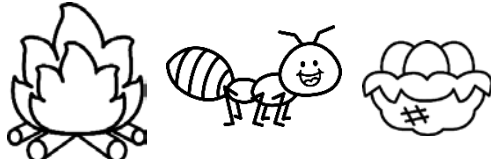

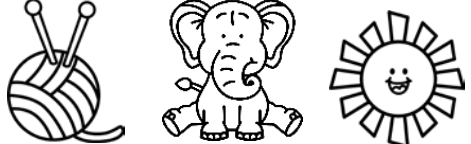

RHYMING Spin & Color

Directions: Spin the spinner. Color one picture that rhymes with that word.

Name: _____

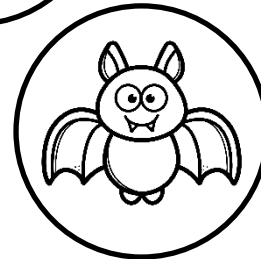
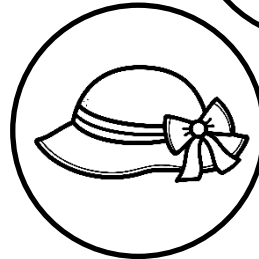
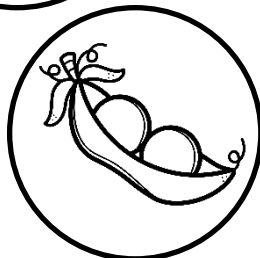
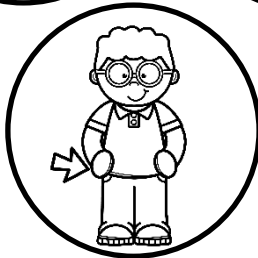
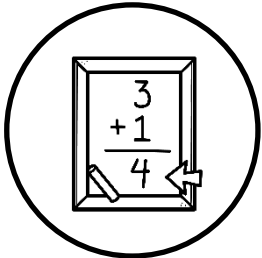
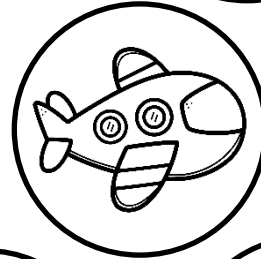
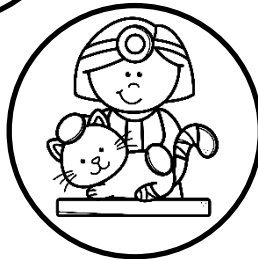
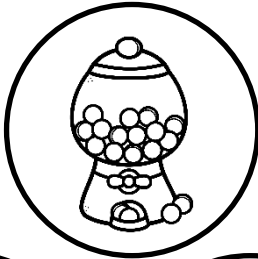
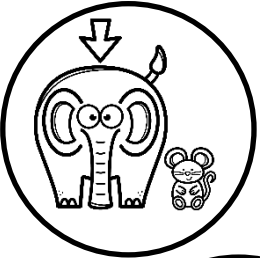
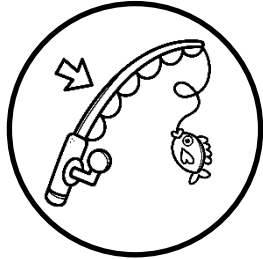
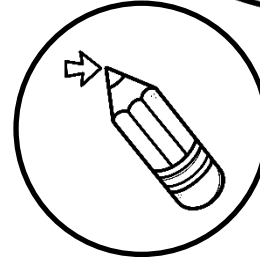
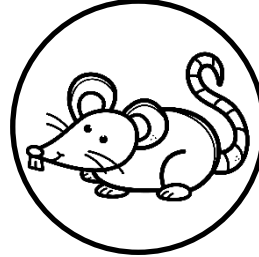
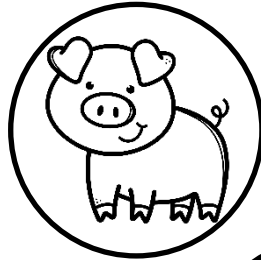
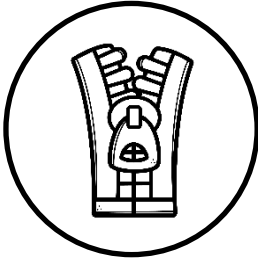
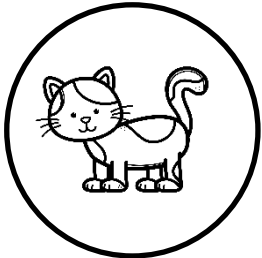
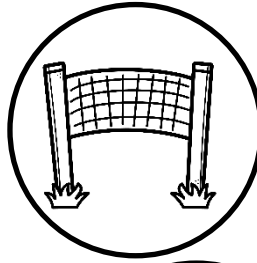
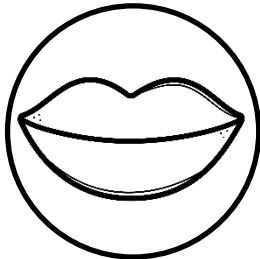
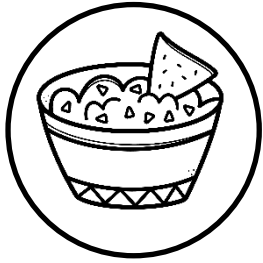
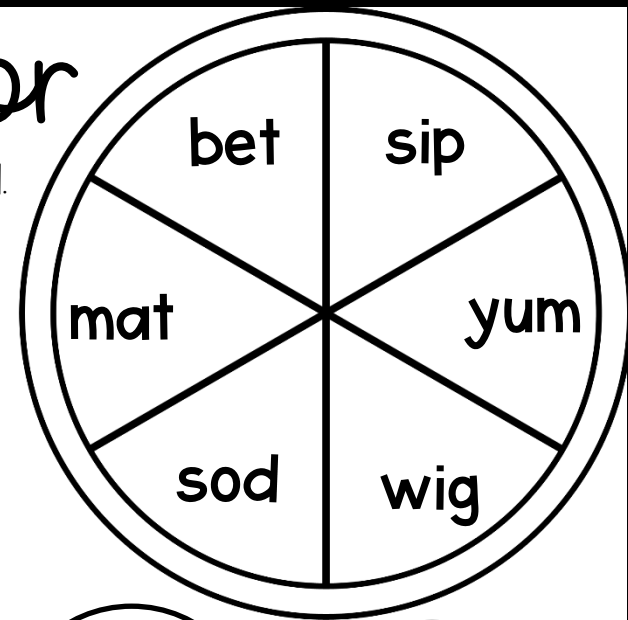

RHYMING Spin & Color

Directions: Spin the spinner. Color one picture that rhymes with that word.

Name: _____

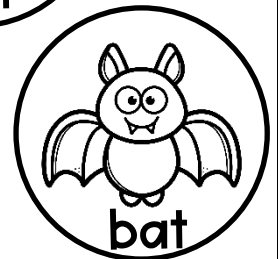
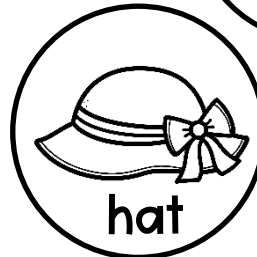
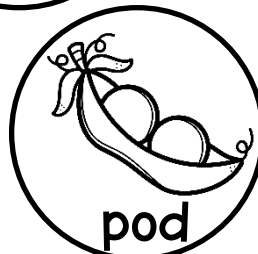
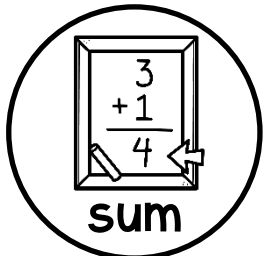
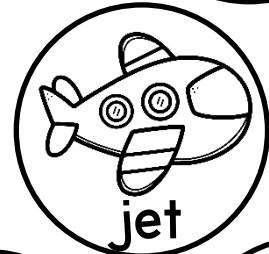
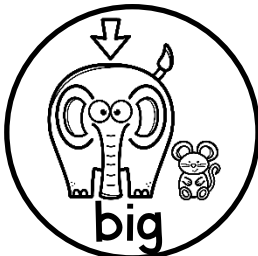
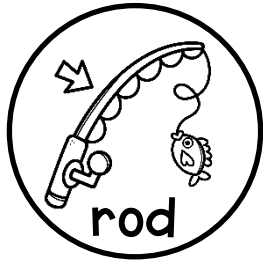
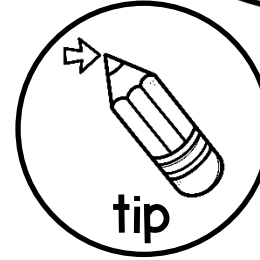
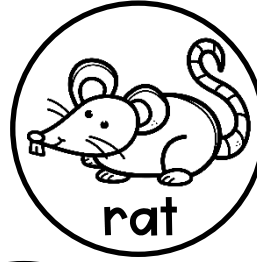
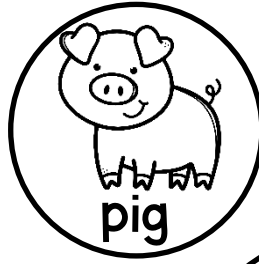
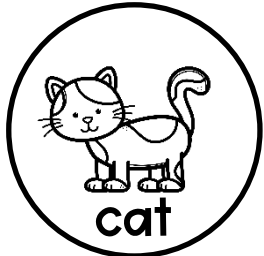
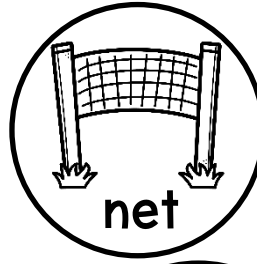
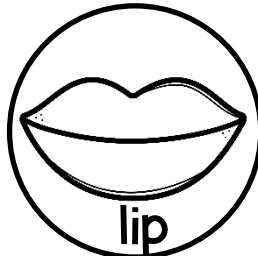
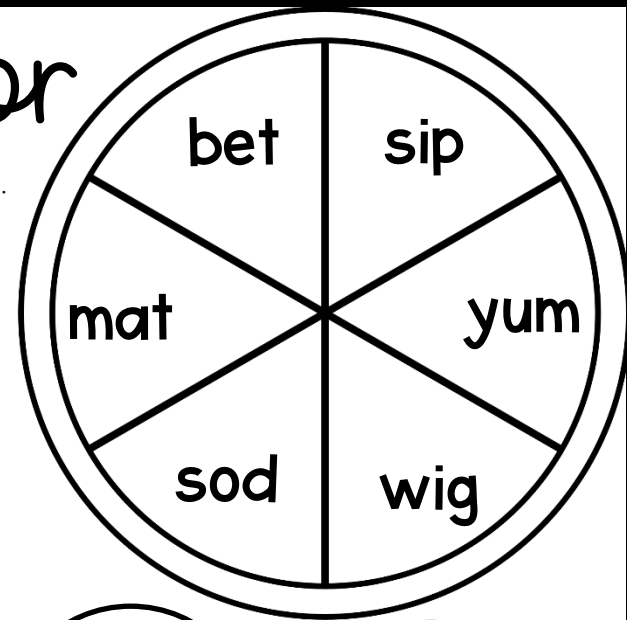

RHYMING Spin & Color

Directions: Spin the spinner. Color one picture that rhymes with that word.

Name: _____

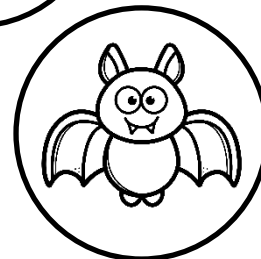
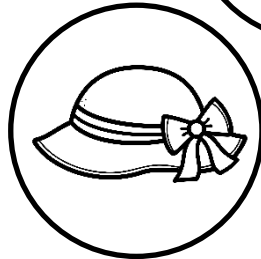
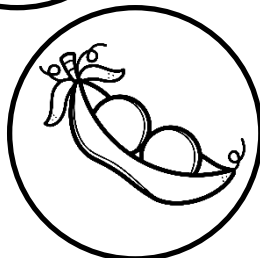
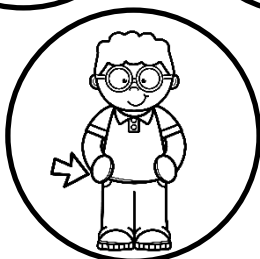
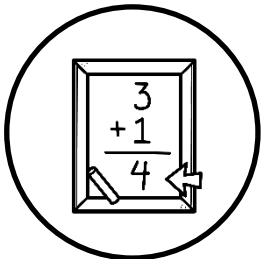
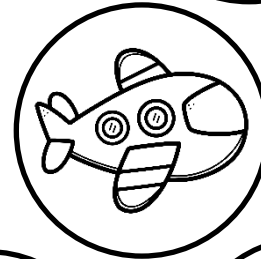
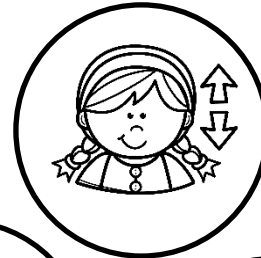
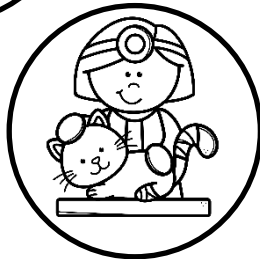
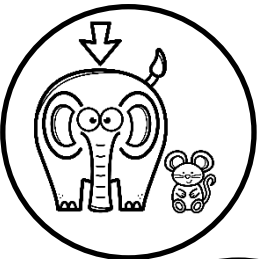
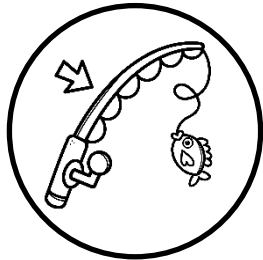
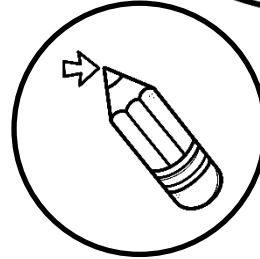
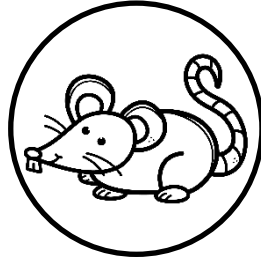
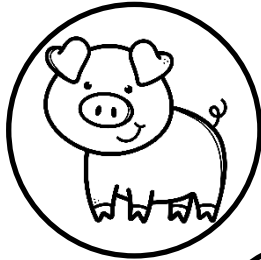
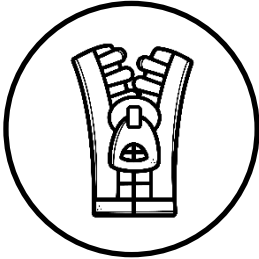
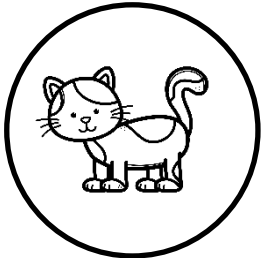
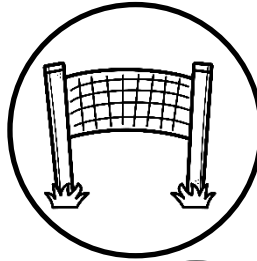
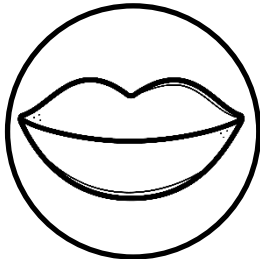
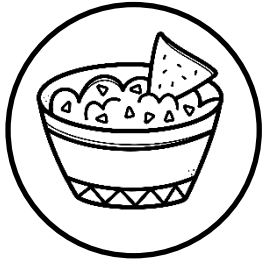
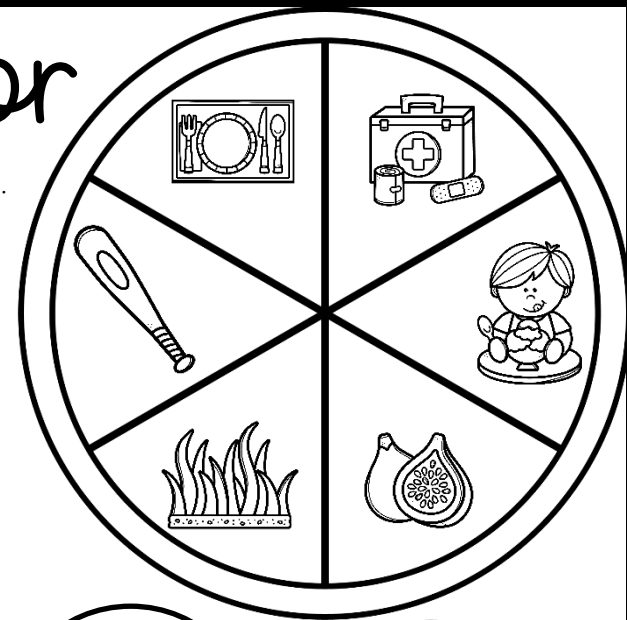

1

Spell this word.

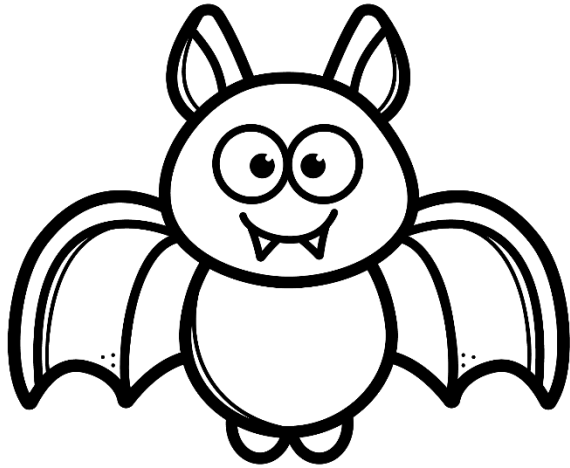

2

Spell this word.



3

Spell this word.

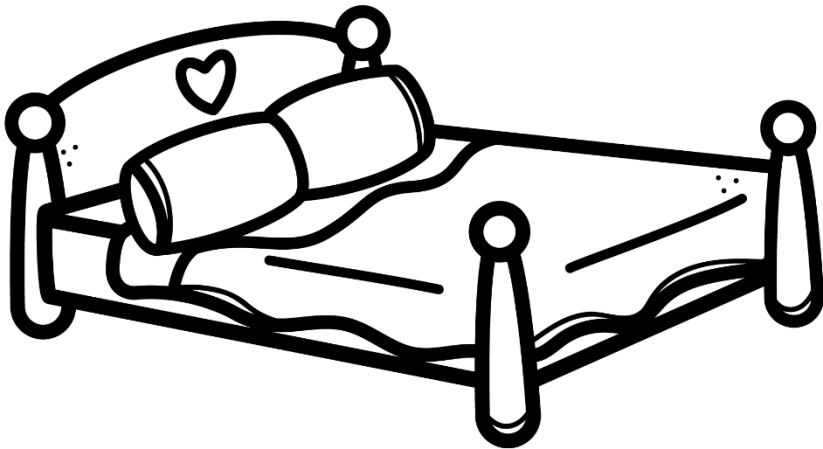

4

Spell this word.

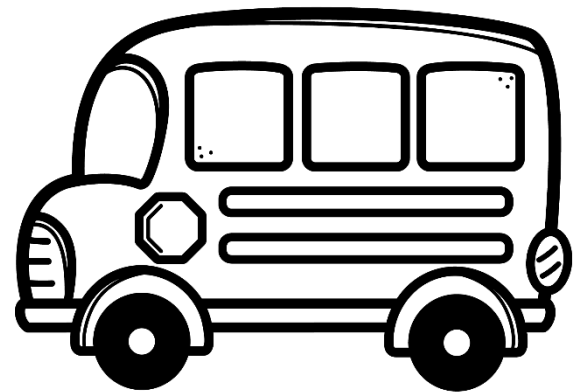

5

Spell this word.

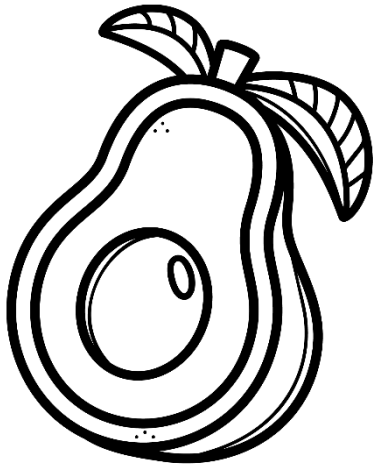

6

Spell this word.

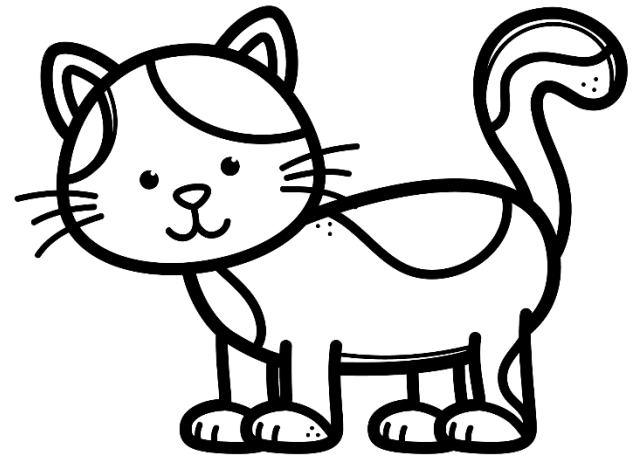

7

Spell this word.

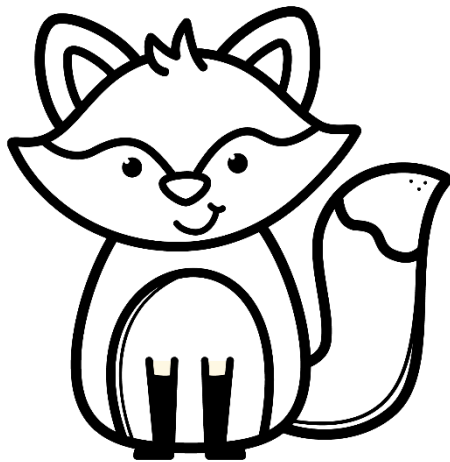

8

Spell this word.

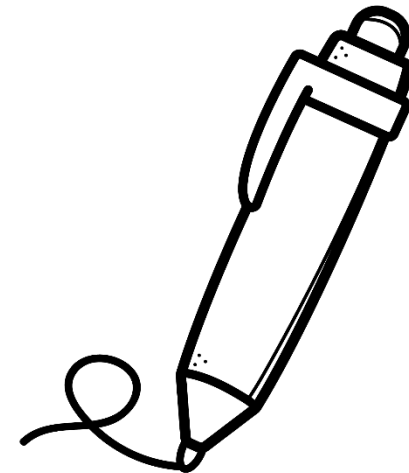

Spell this word.

9



Spell this word.

10

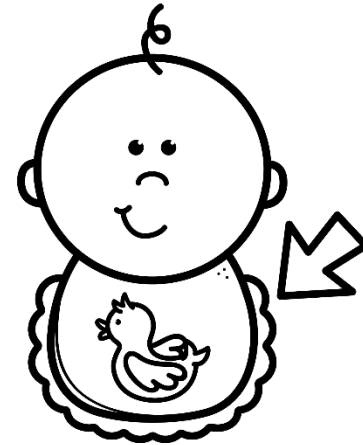

Spell this word.

11



Spell this word.

12

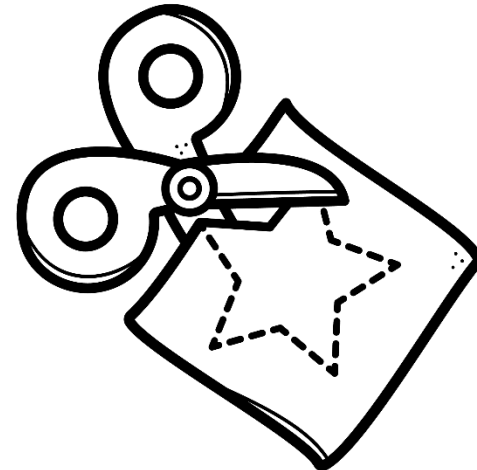

13

Spell this word.

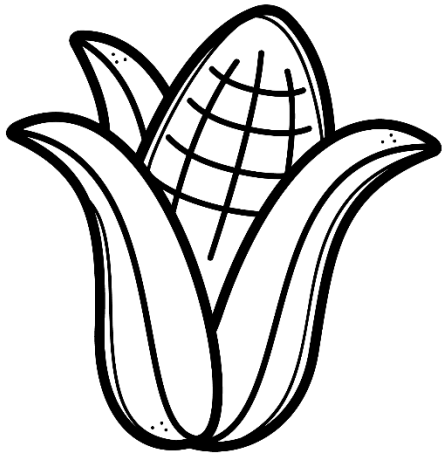

14

Spell this word.

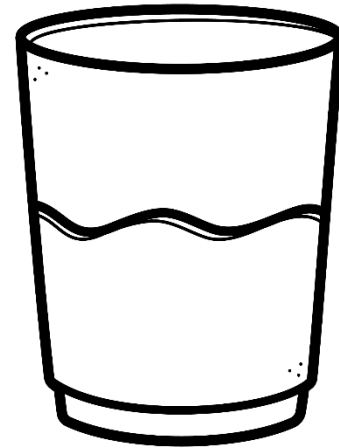

15

Spell this word.

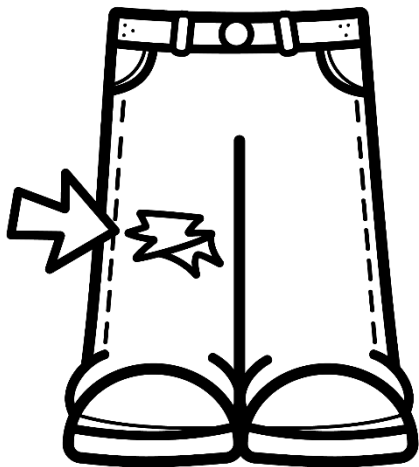

16

Spell this word.



AROUND the ROOM Scoot

Name: _____

RECORDING SHEET

1 _____ _____	2 _____ _____	3 _____ _____	4 _____ _____
5 _____ _____	6 _____ _____	7 _____ _____	8 _____ _____
9 _____ _____	10 _____ _____	11 _____ _____	12 _____ _____
13 _____ _____	14 _____ _____	15 _____ _____	16 _____ _____

AROUND the ROOM Scoot

Name: _____

RECORDING SHEET

1 ____ a ____	2 ____ e ____	3 ____ e ____	4 ____ u ____
5 ____ i ____	6 ____ a ____	7 ____ o ____	8 ____ e ____
9 ____ o ____	10 ____ i ____	11 ____ i ____	12 ____ u ____
13 ____ o ____	14 ____ u ____	15 ____ i ____	16 ____ a ____

AROUND the ROOM Scoot

Name: _____

RECORDING SHEET

1 b _____	2 p _____	3 b _____	4 b _____
5 p _____	6 c _____	7 f _____	8 p _____
9 m _____	10 b _____	11 m _____	12 c _____
13 c _____	14 c _____	15 r _____	16 s _____

AROUND the ROOM Scoot

Name: _____

RECORDING SHEET

1 ____ _ t	2 ____ _ t	3 ____ _ d	4 ____ _ s
5 ____ _ t	6 ____ _ t	7 ____ _ x	8 ____ _ n
9 ____ _ m	10 ____ _ b	11 ____ _ x	12 ____ _ t
13 ____ _ b	14 ____ _ p	15 ____ _ p	16 ____ _ d

AROUND the ROOM Scoot

Name: _____

RECORDING SHEET

1 b _____ t	2 p _____ t	3 b _____ d	4 b _____ s
5 p _____ t	6 c _____ t	7 f _____ x	8 p _____ n
9 m _____ m	10 b _____ b	11 m _____ x	12 c _____ t
13 c _____ b	14 c _____ p	15 r _____ p	16 s _____ d

August Centers

Syllable Sort

Print, cut, and laminate these cards, then let your students practice sorting by number of syllables. Then, have them record their answers on the form.

1 Syllable				
2 Syllables				
3 Syllables				

SORT the SYLLABLES		
RECORDING SHEET		
Name: _____		
1 syllable	2 syllables	3 syllables

FIND the PAIR RECORDING SHEET	
Words Families	
Name: _____	

Find The Pair Word Families

Kids will sort the pictures into cards by word family. This could be also played as memory or go fish! After all pairs are made, students can record their answers. Differentiated cards included.

t C u x C	
p c e p C	
c C a b C	
s C u b C	

SOLVE the PUZZLES	
RECORDING SHEET	
Name: _____	

Onset-Rime Puzzles

Students will piece together three piece puzzles: onset, rime, and matching picture. Once all puzzles are completed, they can fill in the recording form with the words.

1 Syllable



quiz

2 Syllables

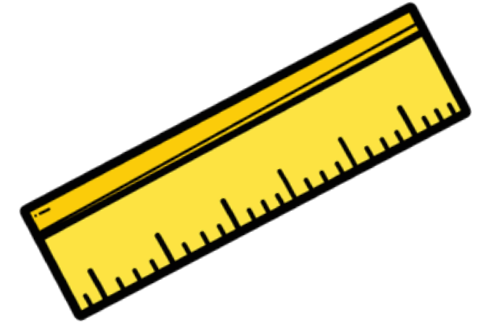

ruler

3 Syllables



umbrella

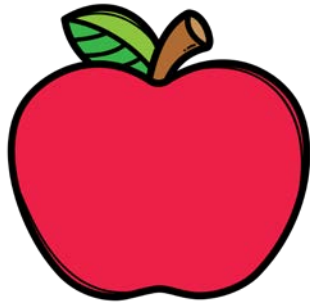

apple



highlighter

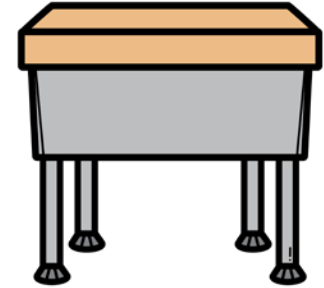

desk



pencil



computer



folder



glue



bus

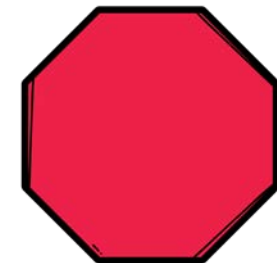

octagon

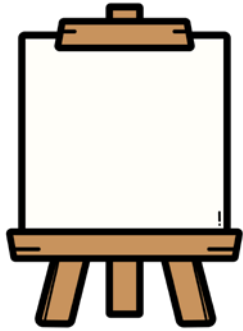

easel



ink

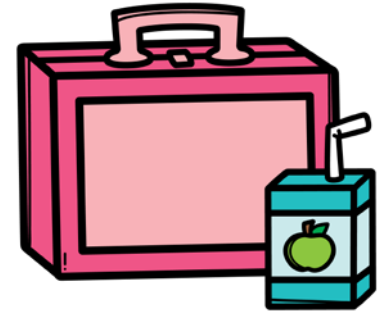

lunchbox



question mark



school



tape

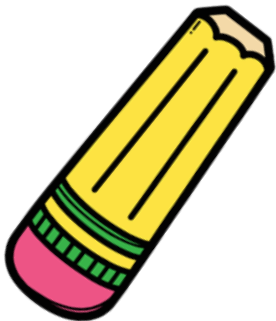

unsharpened



van



xylophone

1 Syllable

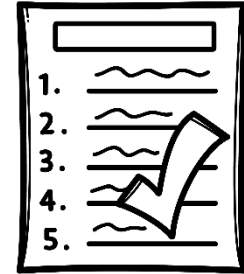

quiz

2 Syllables

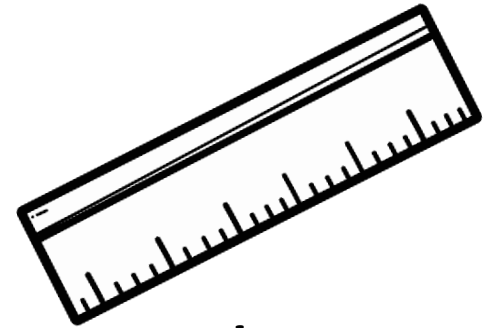

ruler

3 Syllables



umbrella

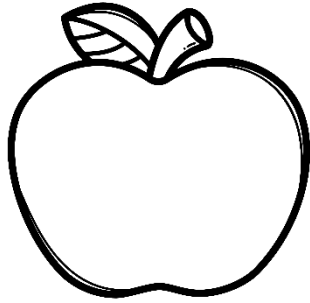

apple



highlighter

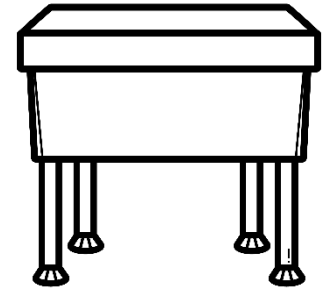

desk

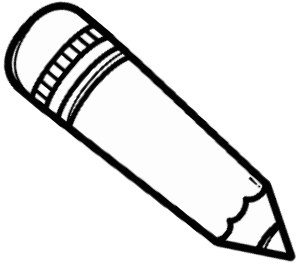

pencil



computer

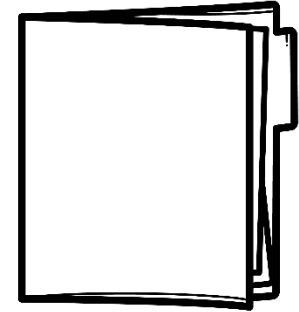

folder

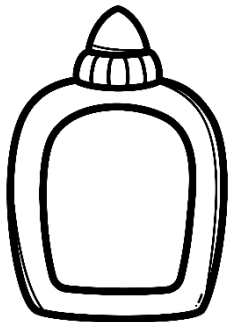

glue

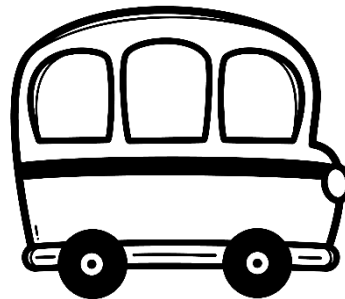

bus

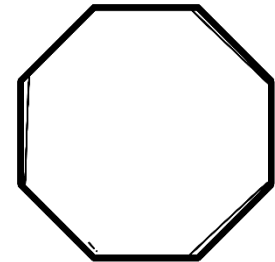

octagon

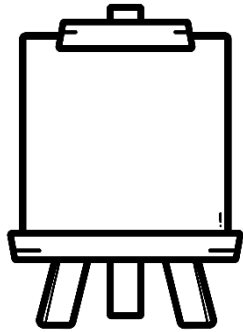

easel



ink

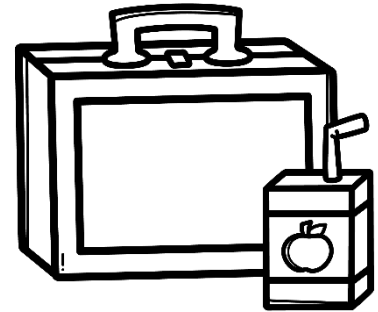

lunchbox



question mark



school

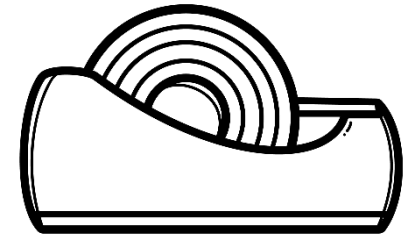

tape

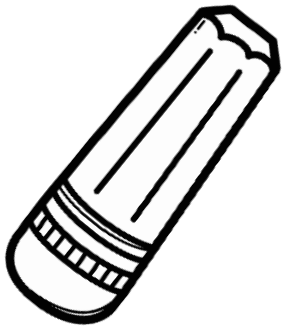

unsharpened

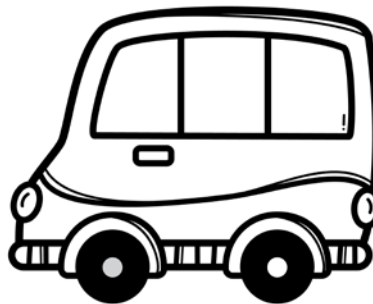

van

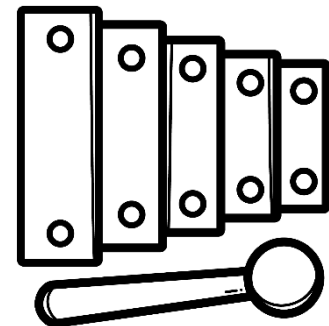

xylophone

SORT the **SYLLABLES**

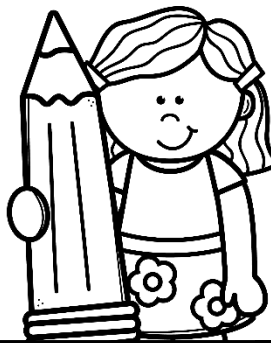

Name: _____ RECORDING SHEET

Directions: Sort the syllable cards. Then, write the words in the correct column.

1 Syllable

2 Syllables

3 Syllables

--	--	--

--	--	--

--	--	--

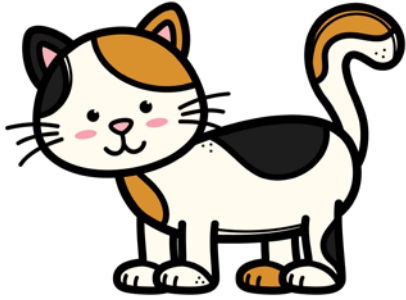

cat

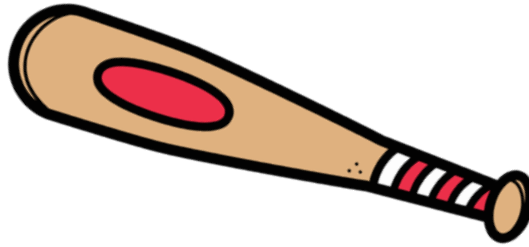

bat

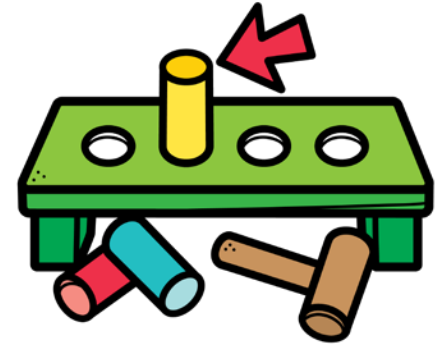

peg

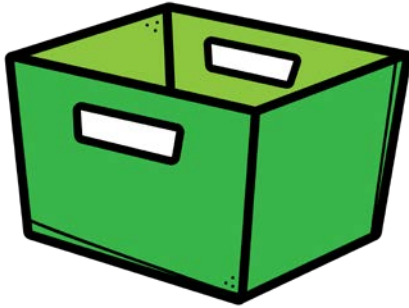

bin

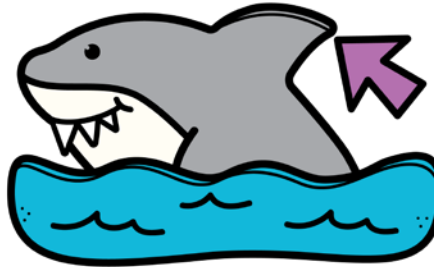

fin

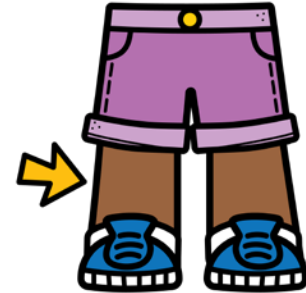

leg

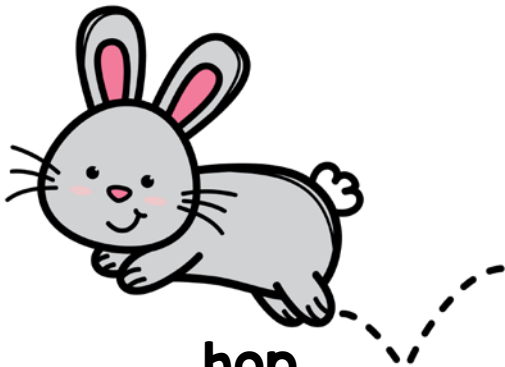

hop



mop



bug

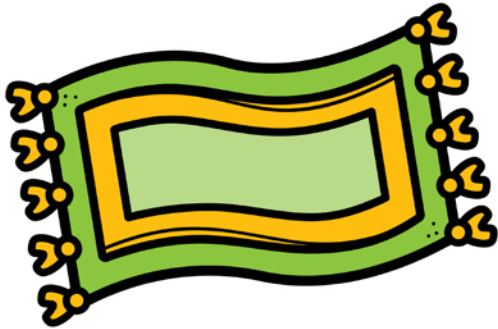

rug



gem



hem



dog



six



fix



fog

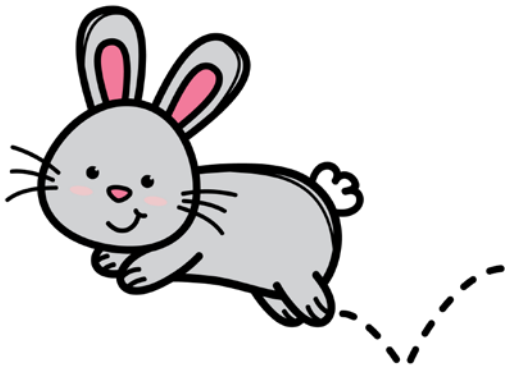
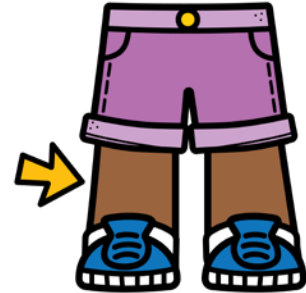
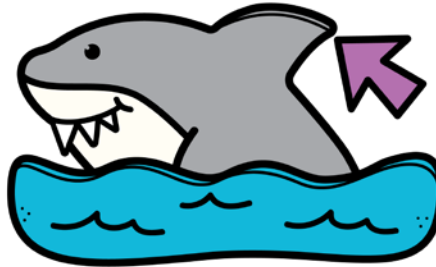
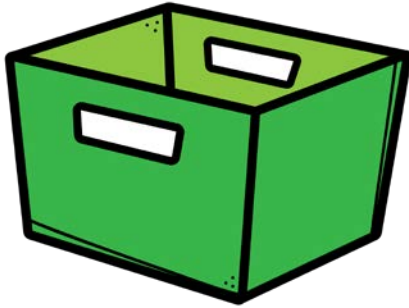
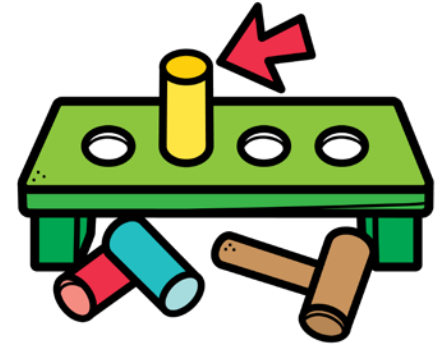
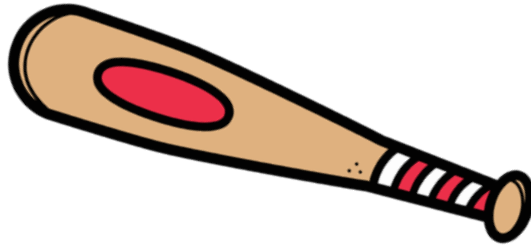
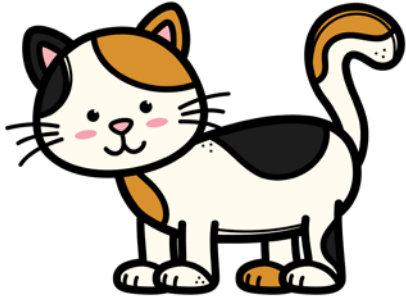

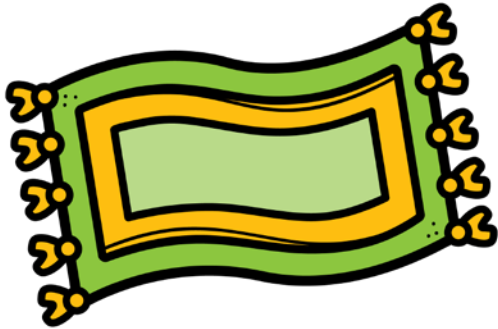

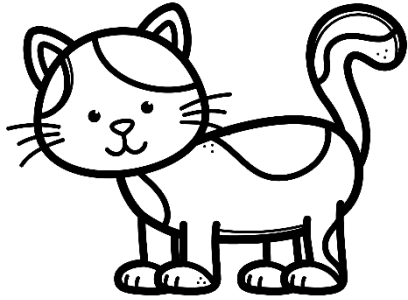

cat

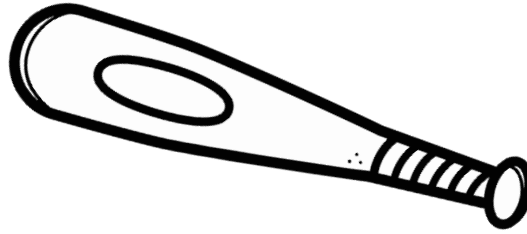

bat

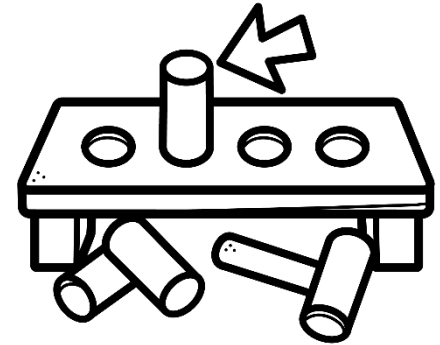

peg

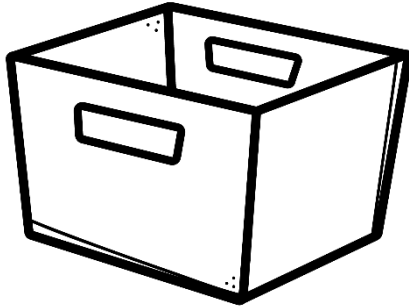

bin

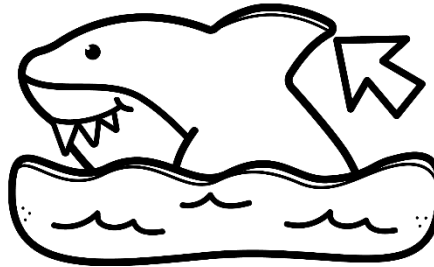

fin

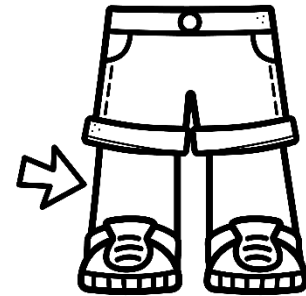

leg

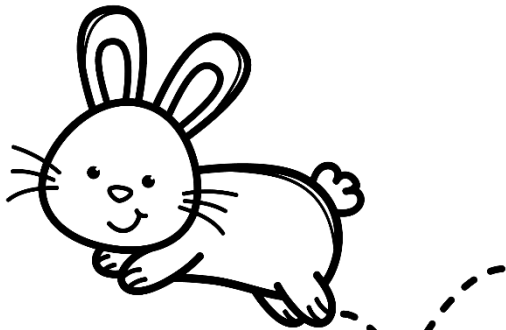

hop



mop

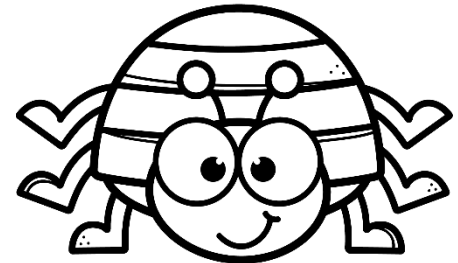

bug

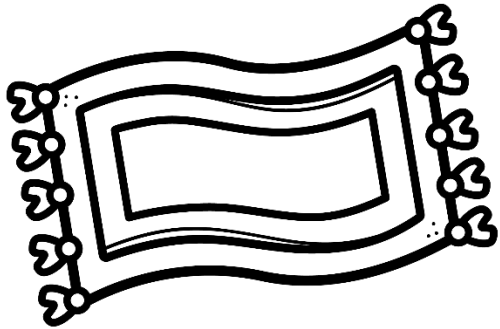

rug

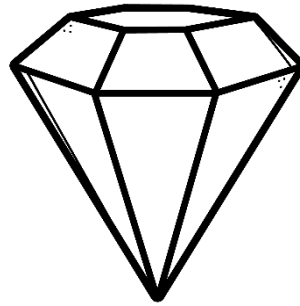

gem



hem

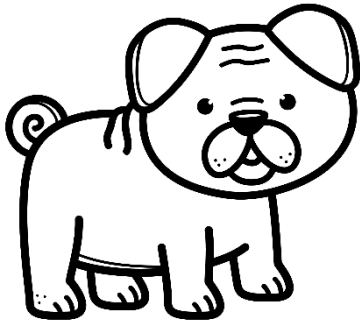

dog

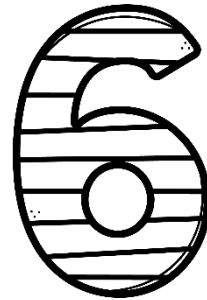

six



fix

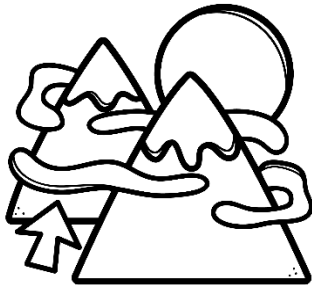

fog

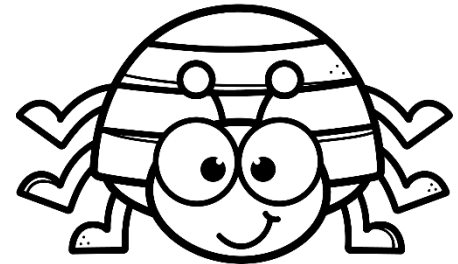
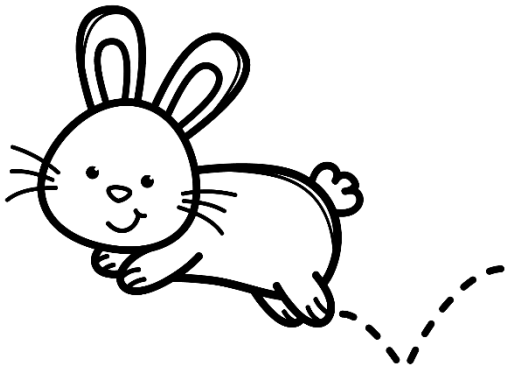
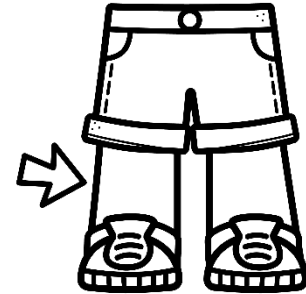
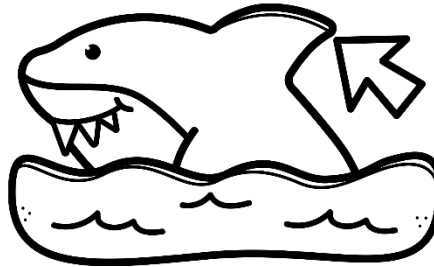
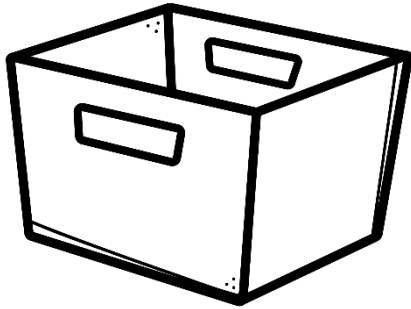
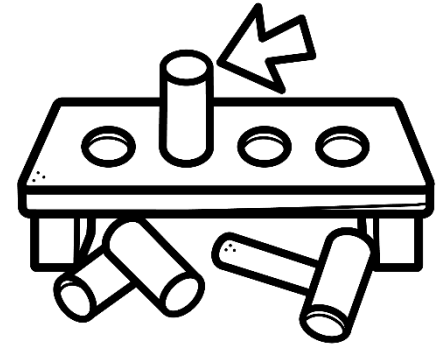
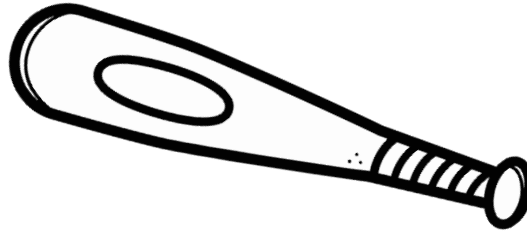
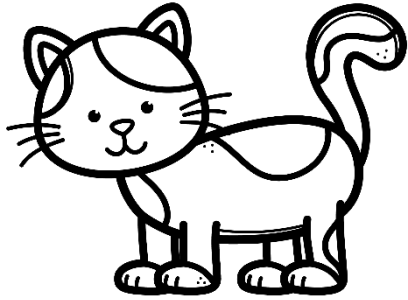

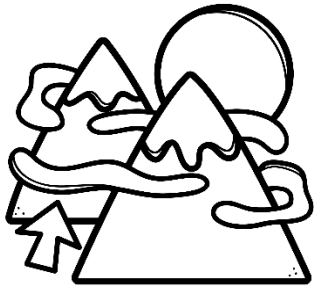
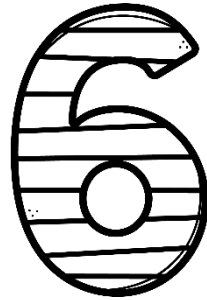
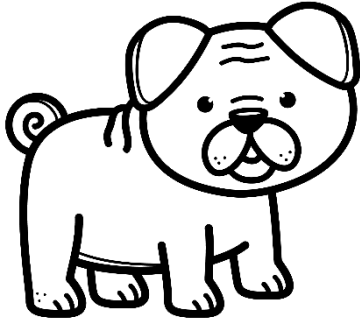
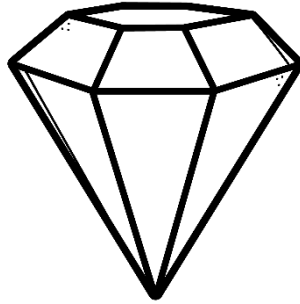
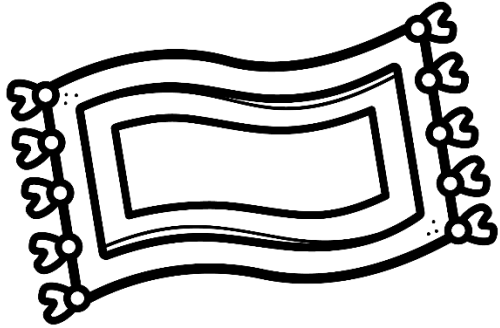

FIND the PAIR RECORDING SHEET

Name: _____

Word Families



Directions: Match the cards. Then, write the pairs in the boxes.

--	--

--	--

--	--

--	--

--	--

--	--

--	--

--	--

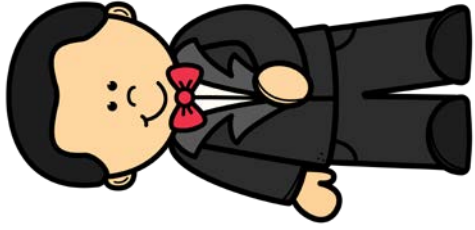

t

ux



l

og

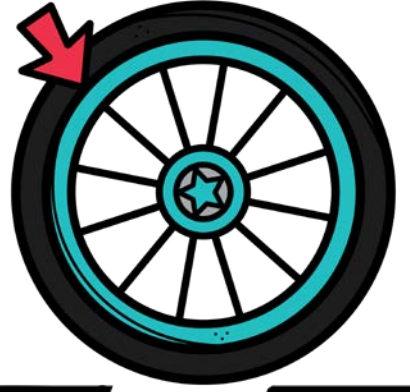

r

imc



p

ep

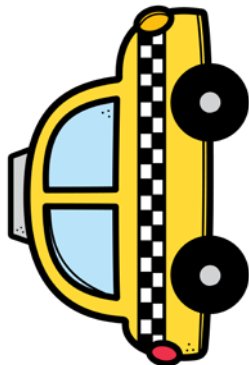

c

cab

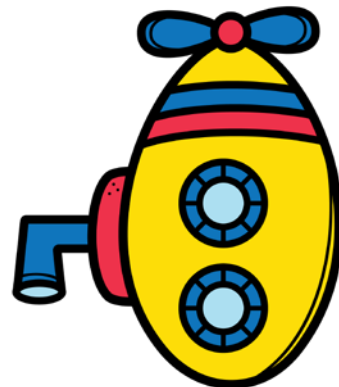

s

sub

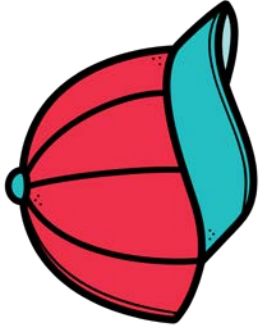

c cap



d den

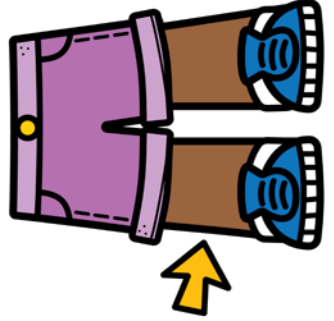

i eg

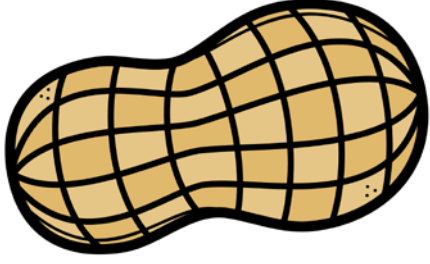

n cut

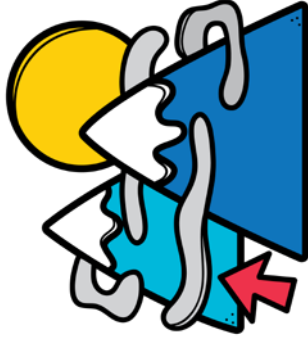

f og

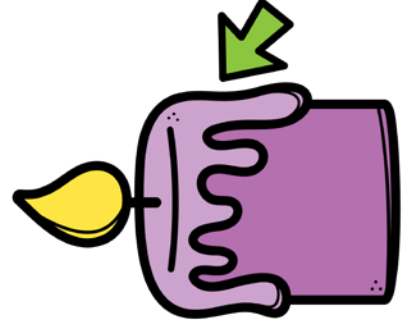

w ax

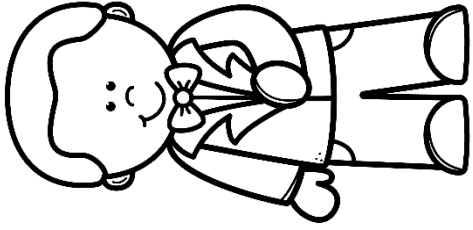

t

uxn



l

og

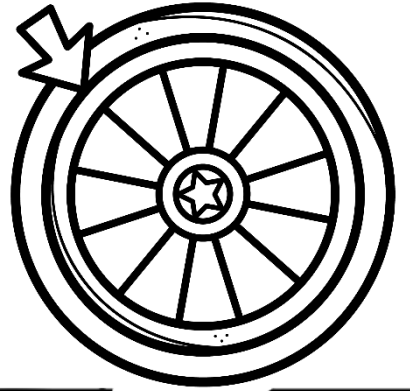

r

imc

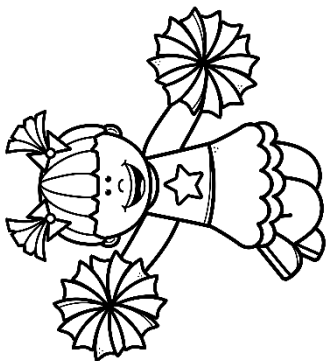

p

ep

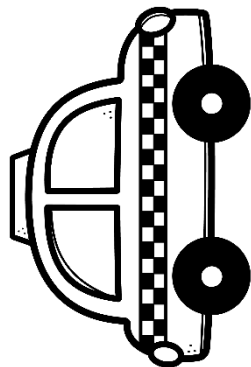

c

cab

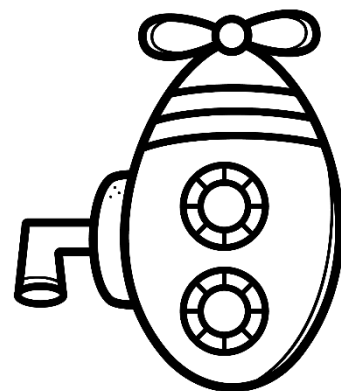

s

sub

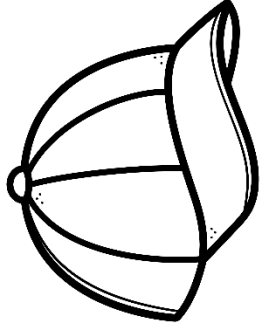

c cap

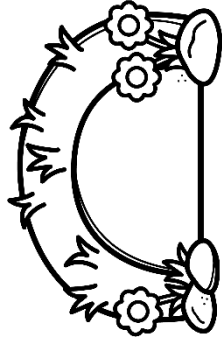

d den

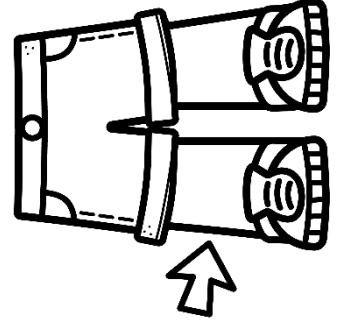

l leg

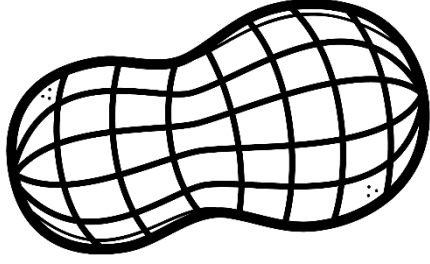

n
c
u
t

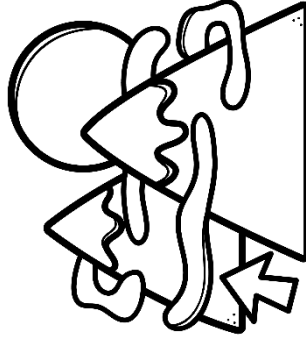

f
o
g

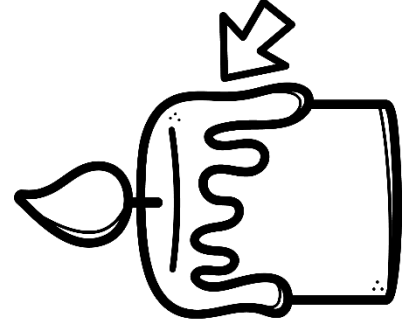

w
a
x

SOLVE the PUZZLES

RECORDING SHEET

Name: _____

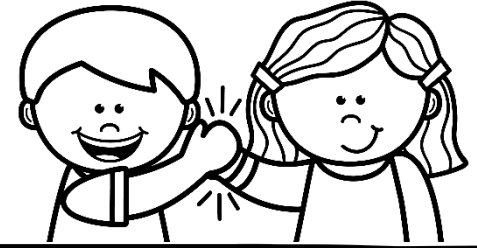

Directions: Solve the puzzles. Write the answers in the boxes.

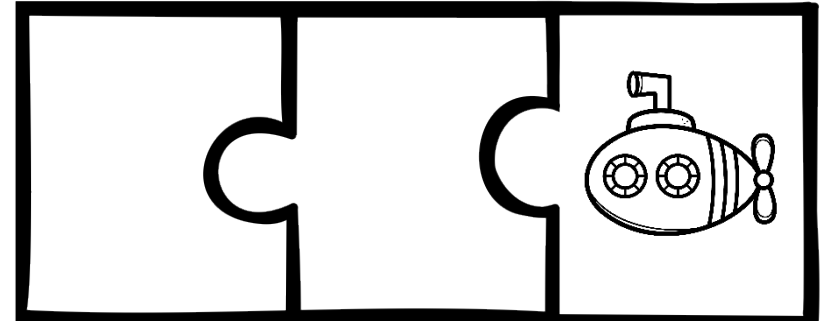
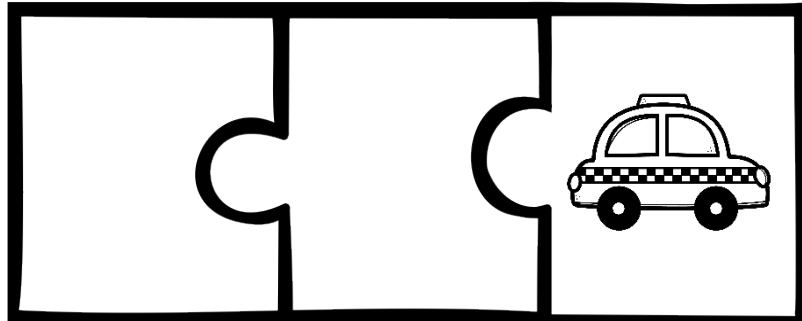
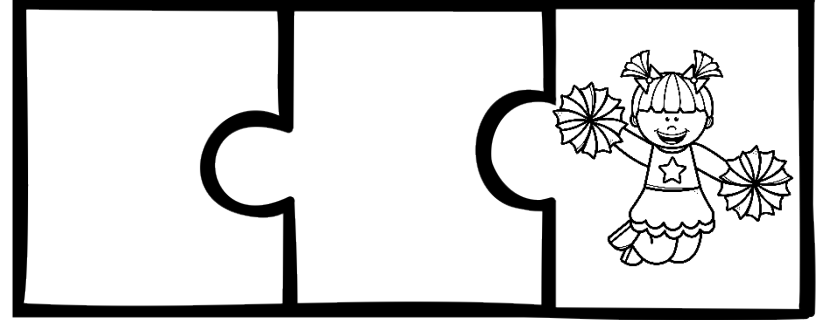
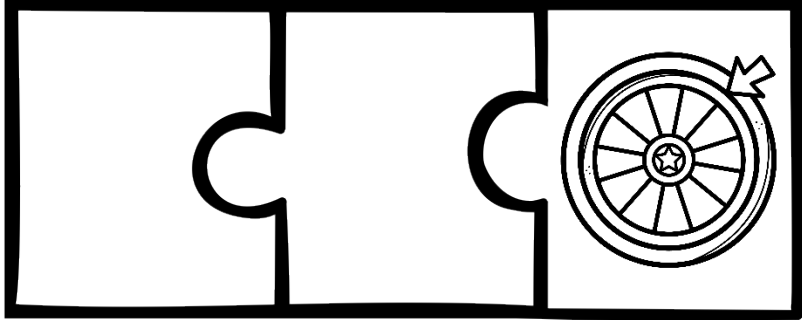
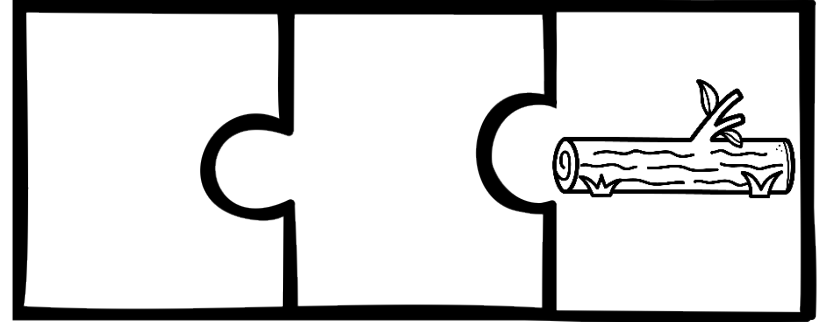
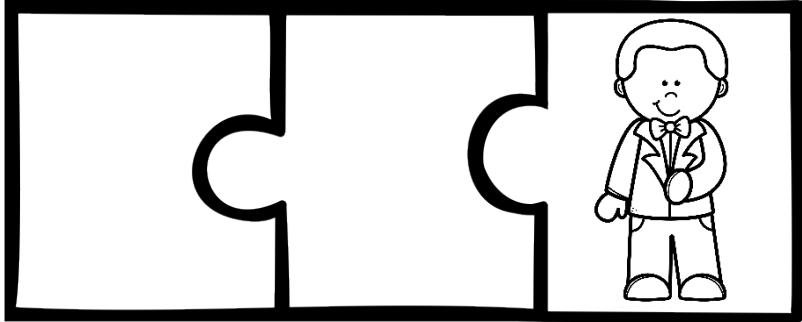

SOLVE the PUZZLES

RECORDING SHEET

Name: _____

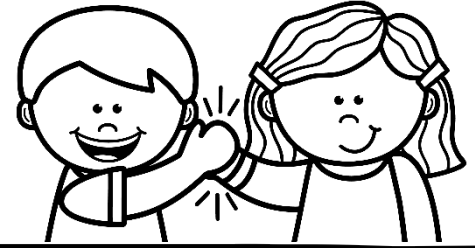

Directions: Solve the puzzles. Write the answers in the boxes.

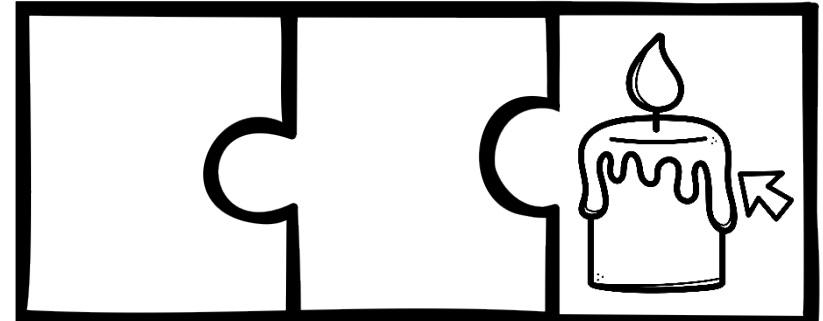
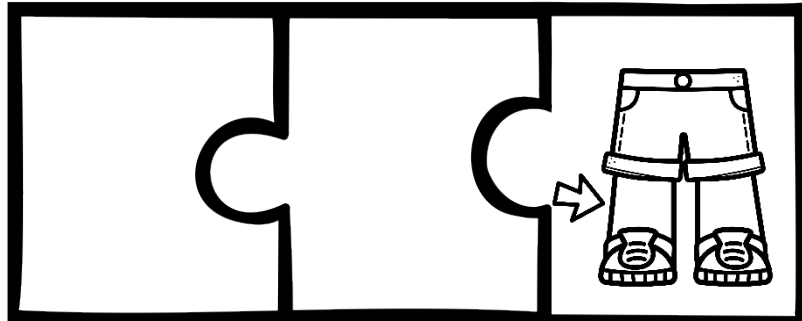
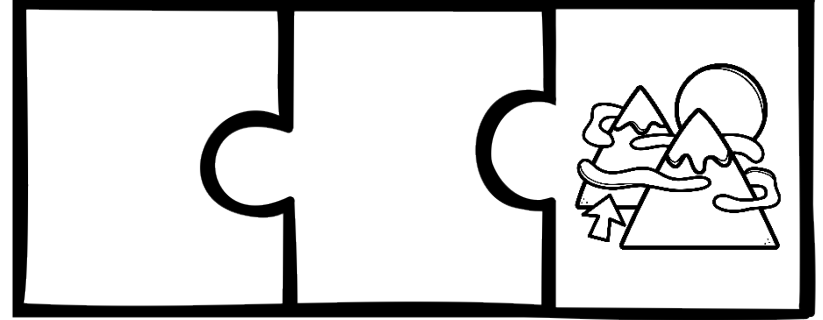
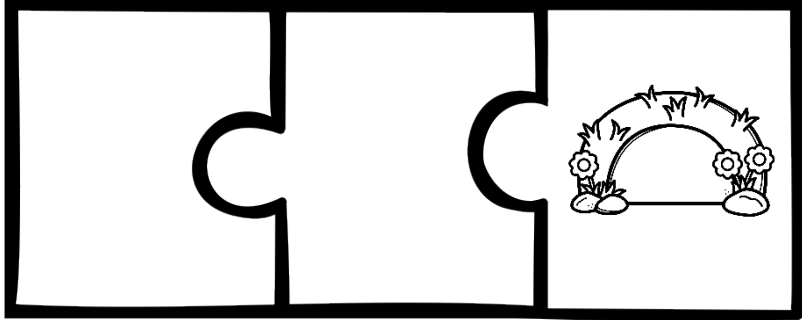
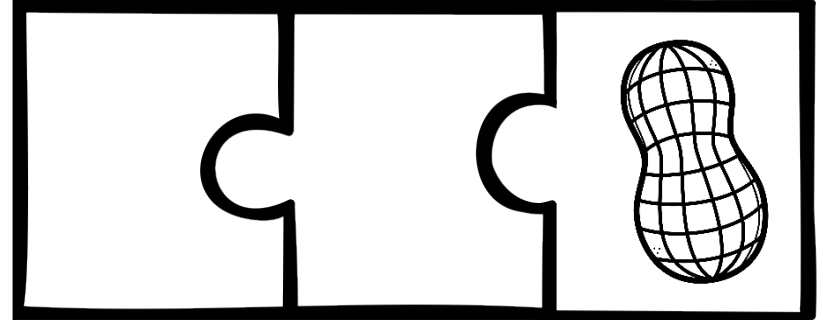
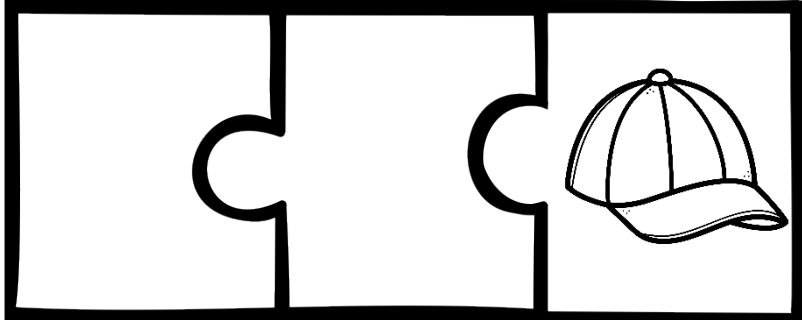

August Centers

Medial Sound Clip Cards

Kids can clip all the pictures that have the given medial sound. Once they are done clipping the cards, they can use one of the given forms to record their answers.

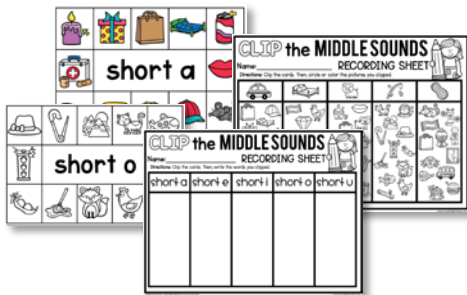

Build The Sight Words

Kids will love this hands-on building center where they can trace, write, and build sight words. Building materials could include tiles, magnets, play doh, or any other classroom materials!

ABC Order Task Cards

These task cards make practicing alphabetization a breeze. Kids will work through the cards and fill out their answers on the recording sheet.



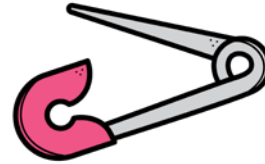
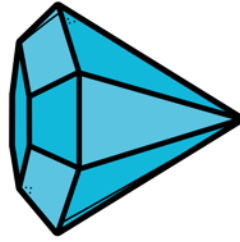

short a



short e

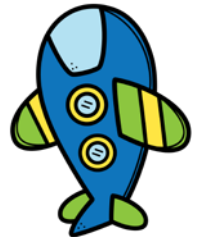
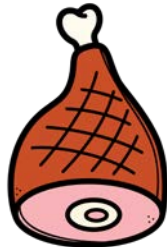
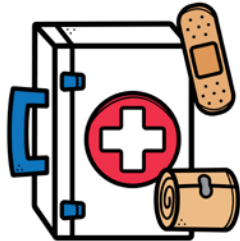
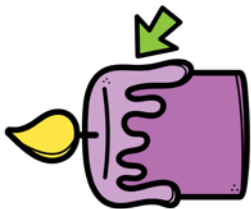
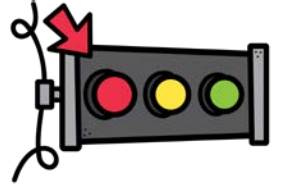
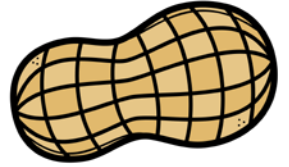
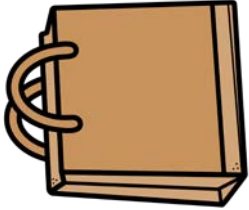
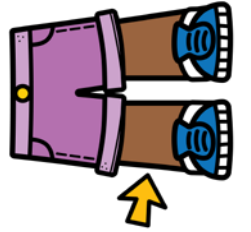

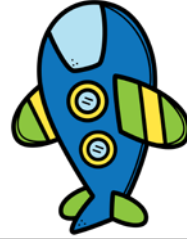
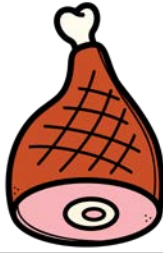
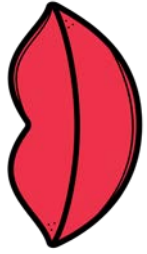

short i

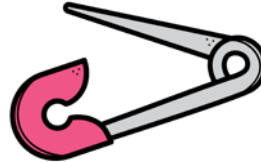
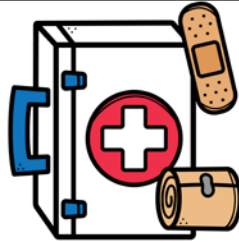
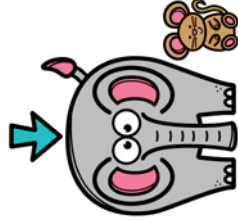

short o

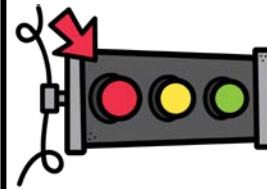
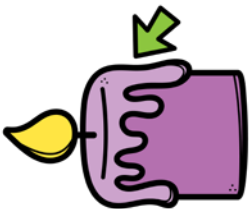

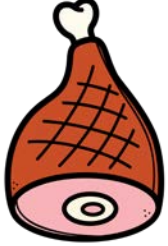
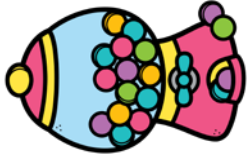

short u

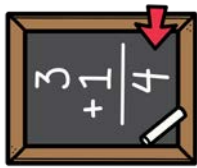
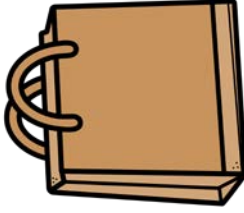

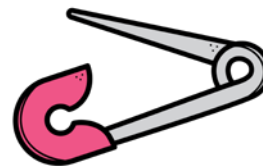
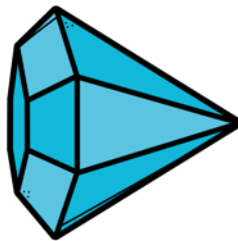







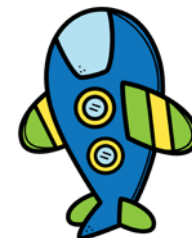
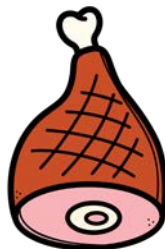
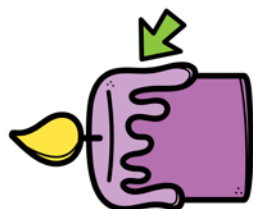
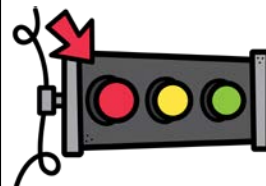
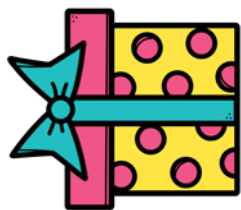
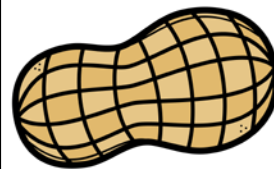
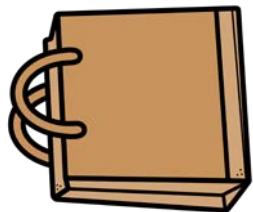
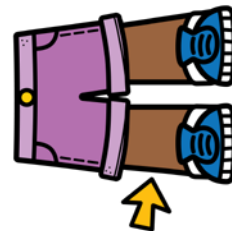

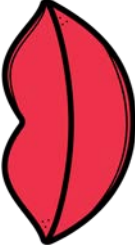

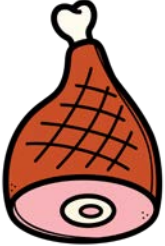

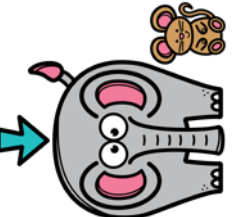



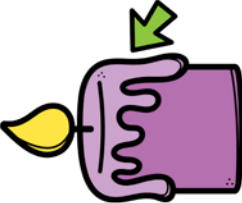





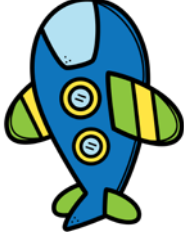

same middle sound as

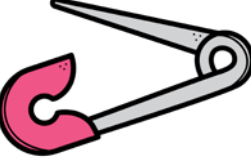

same middle sound as



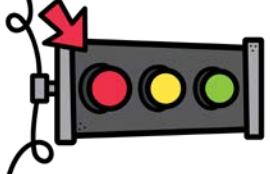

		
	same middle sound as	
		
		
		
		

		
	same middle sound as	
		
		
		
		

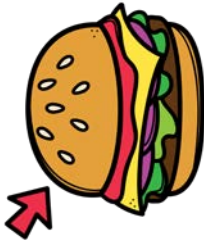
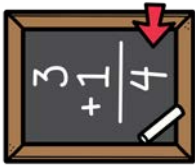
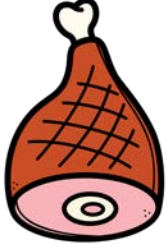
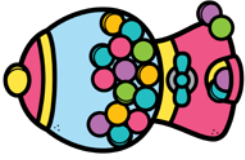

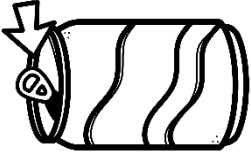
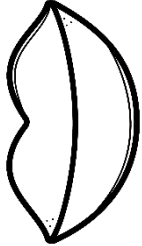

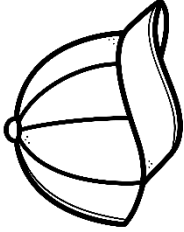
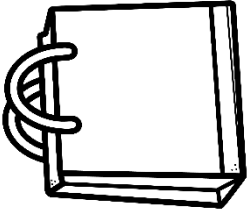
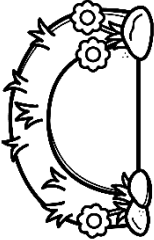
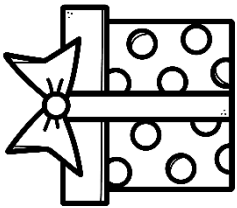
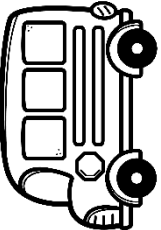
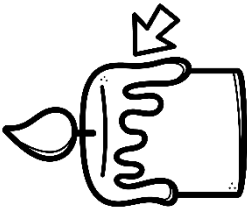
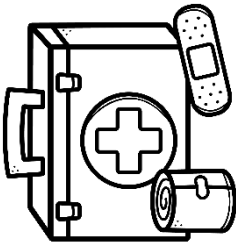
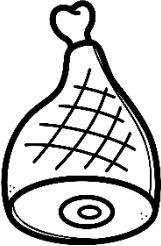
same middle sound as

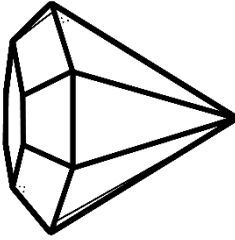
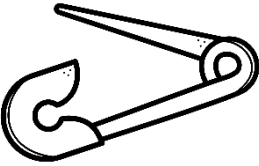
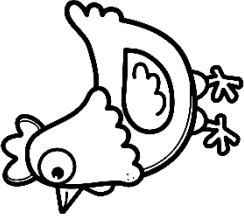
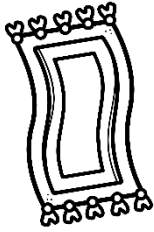
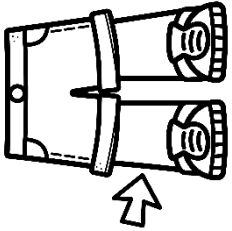
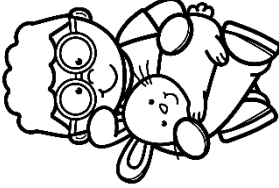
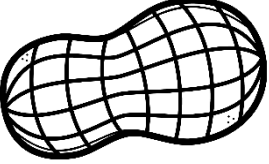
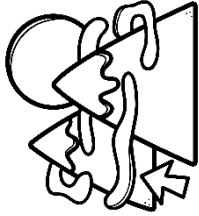
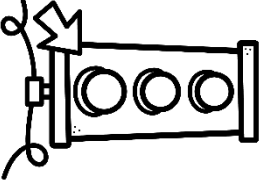
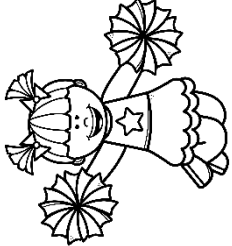
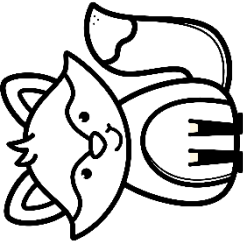
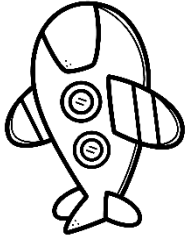

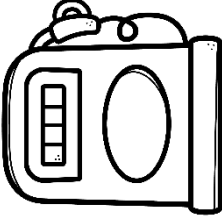
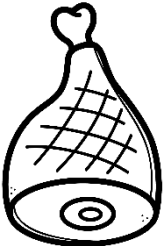
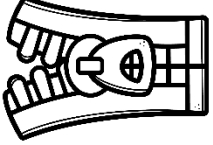
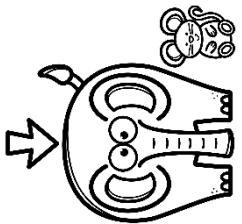
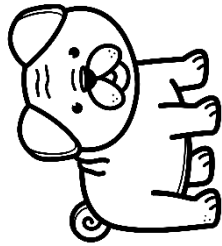
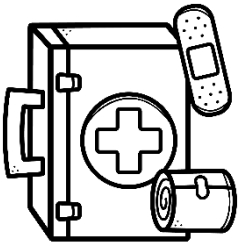
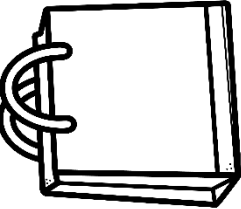
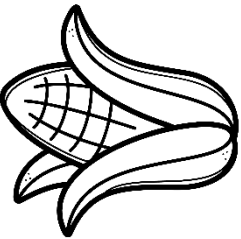
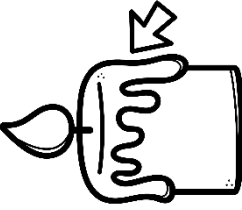
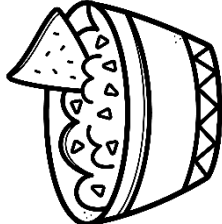
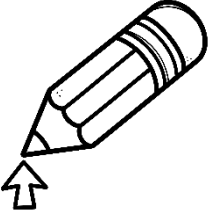
		
	<h1>short a</h1>	
		
		
		
		

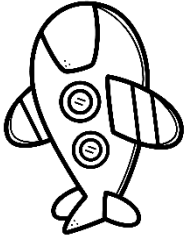
		
	<h1>short e</h1>	
		
		
		
		

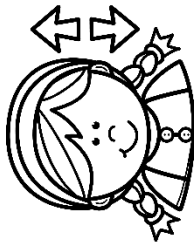
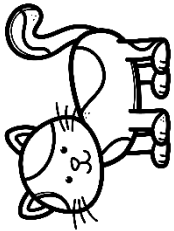
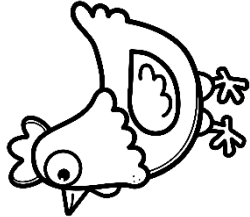
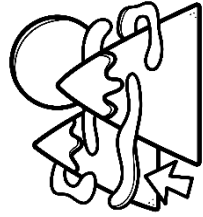
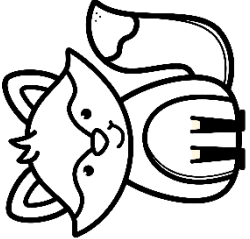
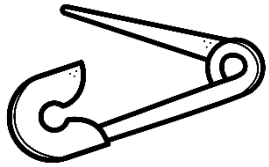
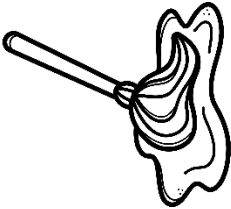
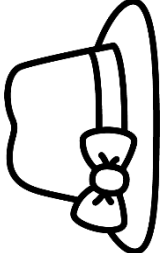
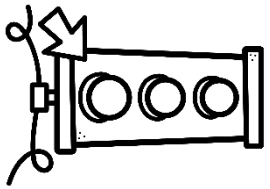

			
	shorti		
			
			
			

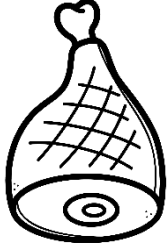
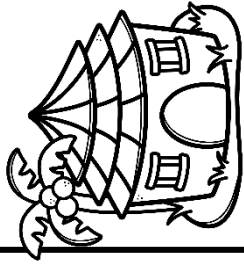
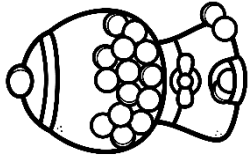
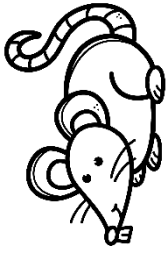

			
	short o		
			
			
			

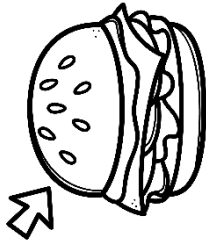
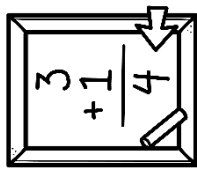
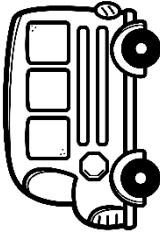
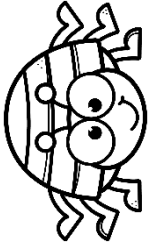
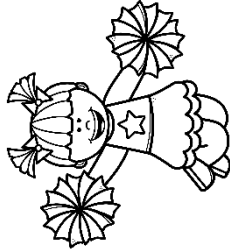
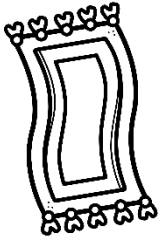
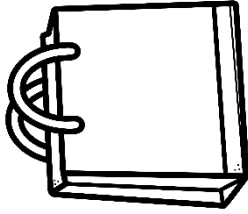

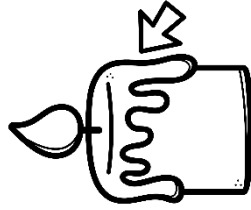

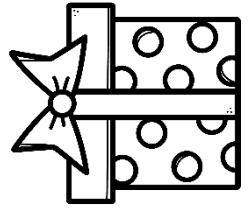
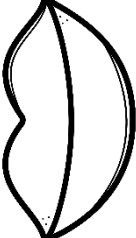
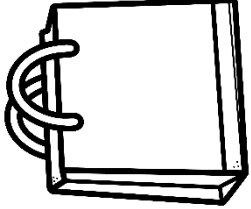
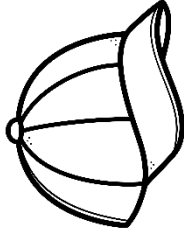
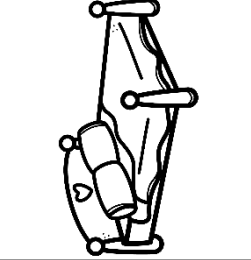
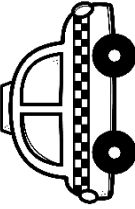
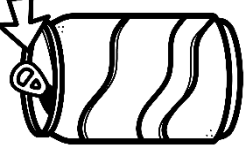
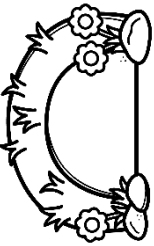
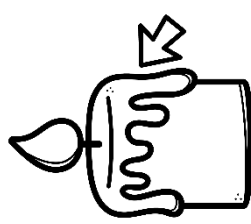
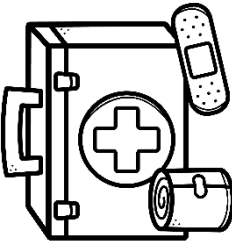
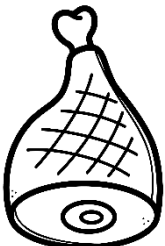

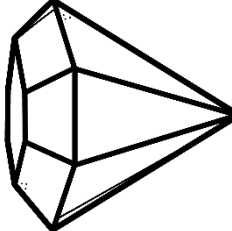
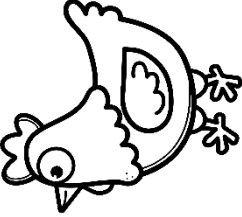
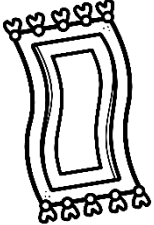
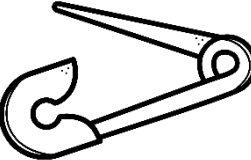
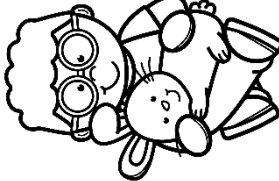
short u

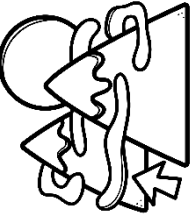
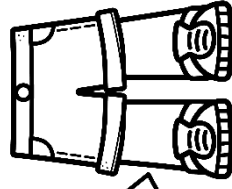
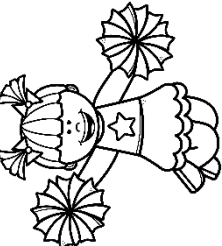
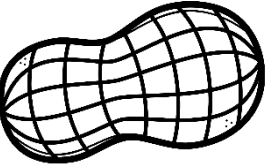
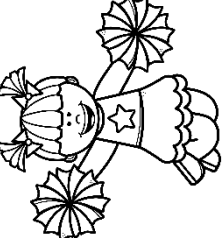
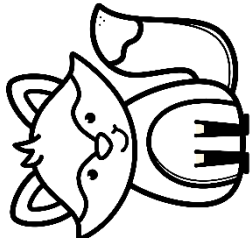
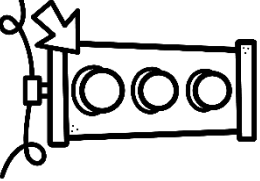
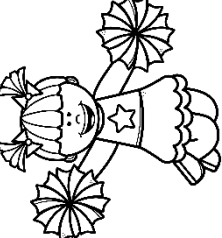
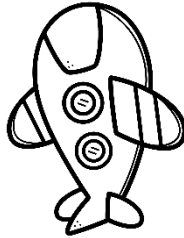

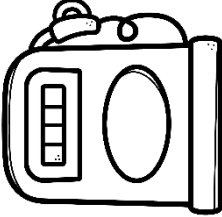
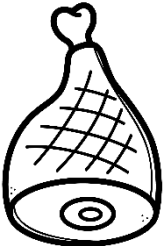
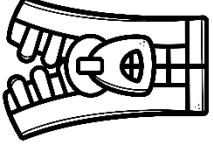
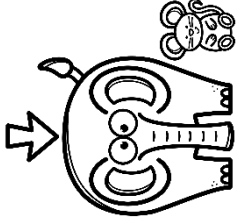
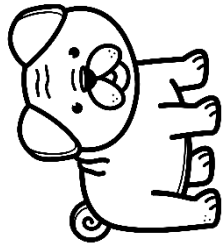
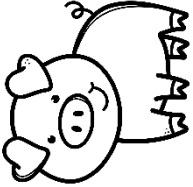
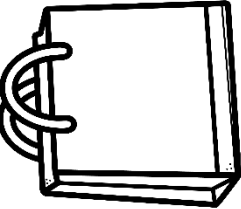
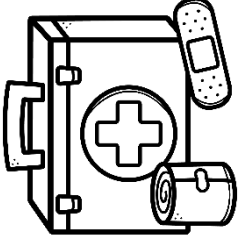
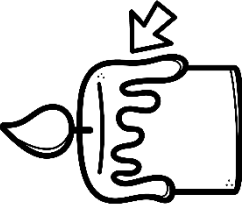
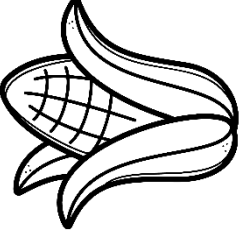
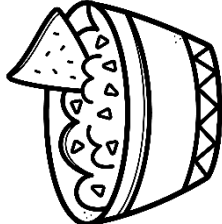
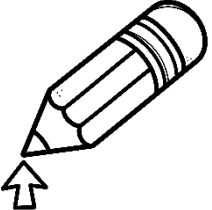
	same middle sound as	
		
		
		
		
		

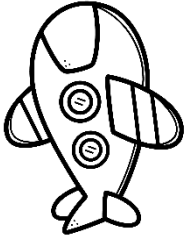
	same middle sound as	
		
		
		
		
		
		

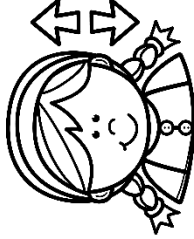
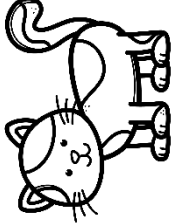
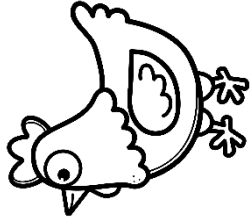
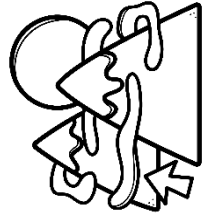
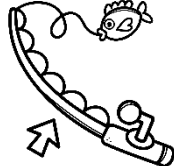
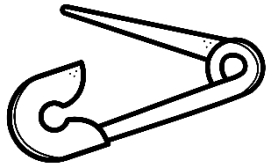
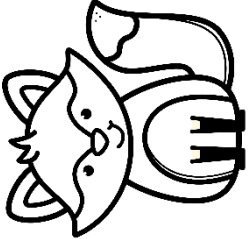
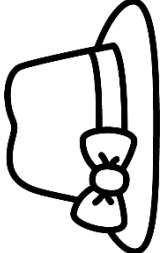
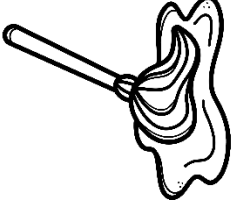
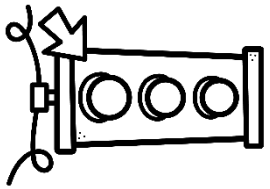
		
	same middle sound as	
		
		
		
		

		
	same middle sound as	
		
		
		
		

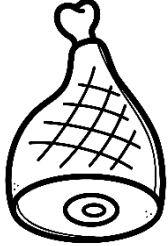
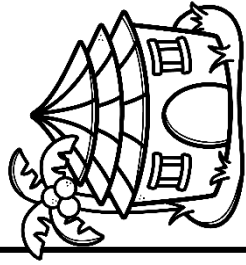
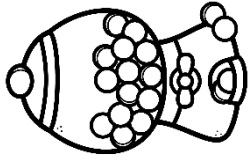
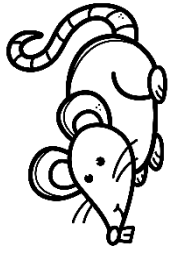

same middle sound as

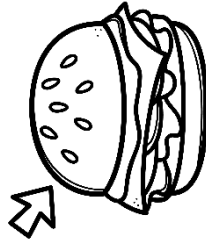
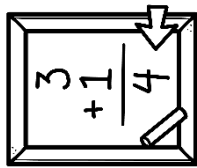
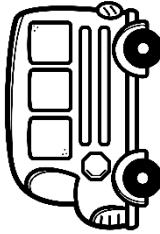
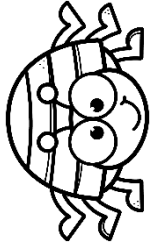
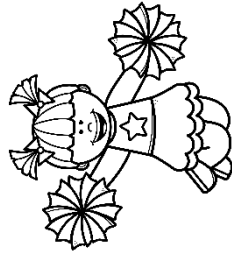
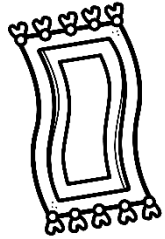
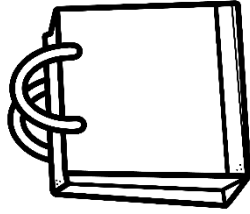

CLIP the MIDDLE SOUNDS

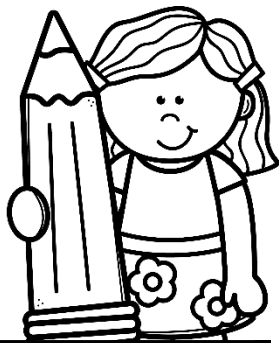

Name: _____ RECORDING SHEET

Directions: Clip the cards. Then, write the words you clipped.

short a	short e	short i	short o	short u

CLIP the MIDDLE SOUNDS

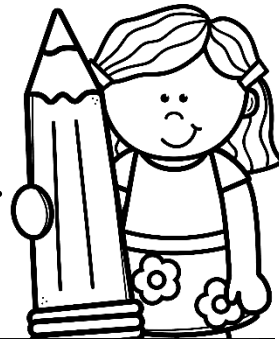

Name: _____

RECORDING SHEET

Directions: Clip the cards. Then, write the words you clipped.

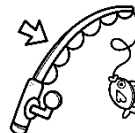
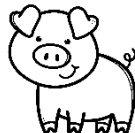

--	--	--	--	--

--	--	--	--	--

--	--	--	--	--

--	--	--	--	--

--	--	--	--	--

CLIP the MIDDLE SOUNDS

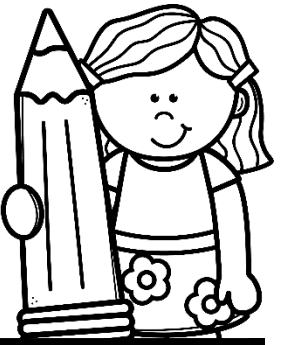

Name: _____

RECORDING SHEET

Directions: Clip the cards. Then, circle or color the pictures you clipped.

short a

short e

short i

short o

short u

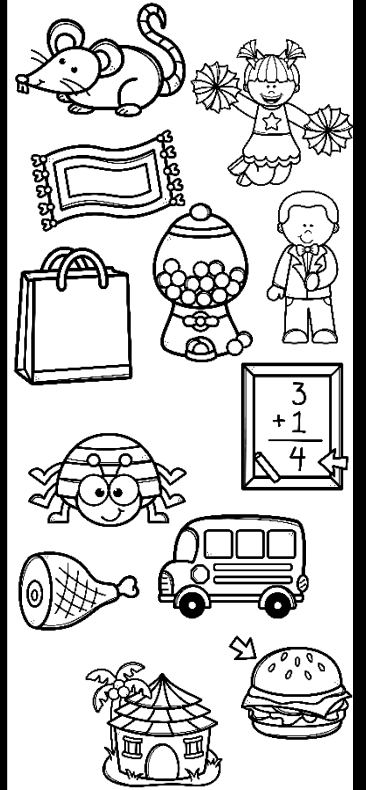
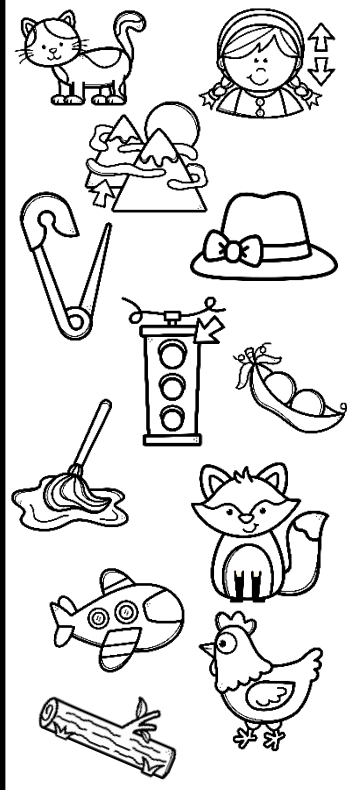
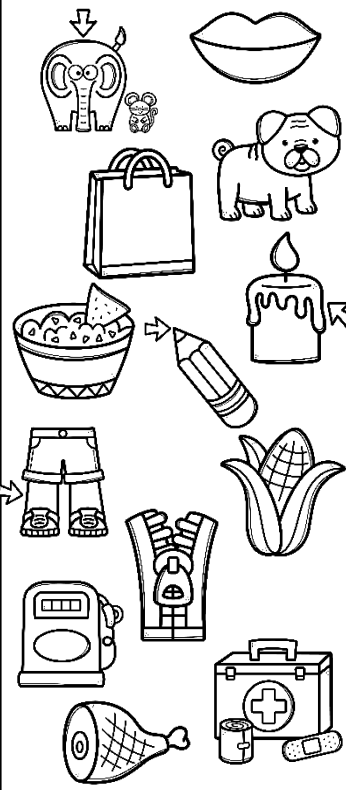
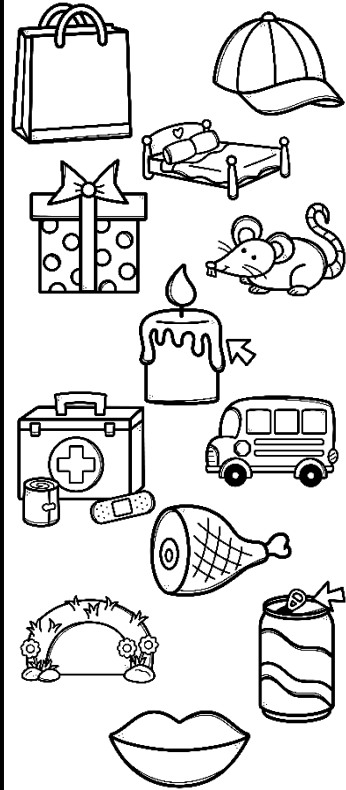



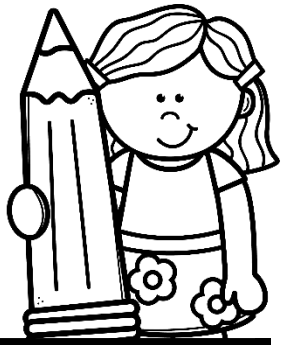









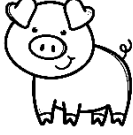
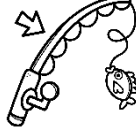
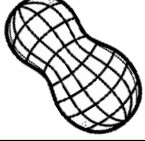













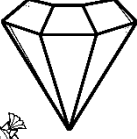





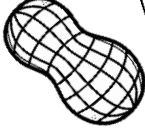

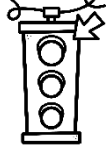





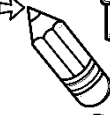
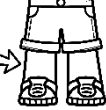

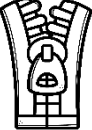







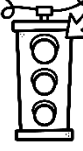





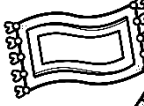

CLIP the MIDDLE SOUNDS

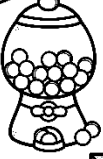

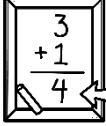
Name: _____

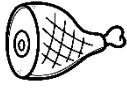
RECORDING SHEET

Directions: Clip the cards. Then, circle or color the pictures you clipped.

BUILD the SIGHT Words

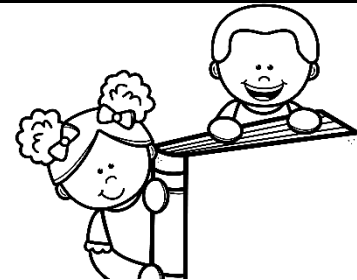

Name: _____

Trace It	Write It	Circle It	Build It
any		any how them going from some any going over when	
from		any how them from from some when over going over when over	
going		any how them how from some going going over when	
how		any how them when from some how going over when	
over		any how them over from some some going over when	
some		any how them some from some from going over when	
them		any how them any from some them going over when	
when		any how them when from some them going over when	

Trace It

any

Write It

Build It

Trace It

from

Write It

Build It

Trace It

going

Write It

Build It

Trace It

how

Write It

Build It

Trace It

over

Write It

Build It

Trace It

some

Write It

Build It

Trace It

them

Write It

Build It

Trace It

when

Write It

Build It

A

Put these words in ABC Order.

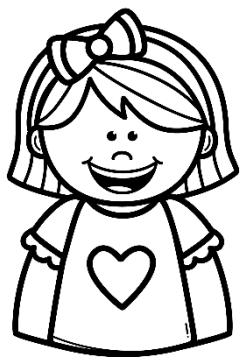

pencil
bus
marker
student

B

Is this list in ABC order?

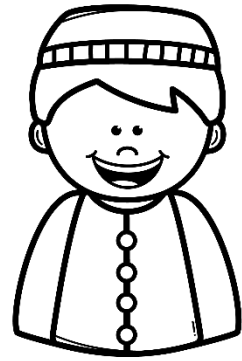

outside
play
sun
teacher

C

Pick 4 classmates and put their names in ABC order.



D

Where would "gym" go on the list below to keep the words in ABC order?



fun
music
school

E

Think of a word to go in the blank spot on the list.

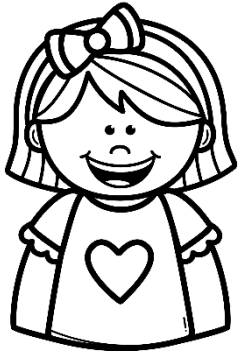

apple
banana

_____ mango

F

Put these words in ABC Order.

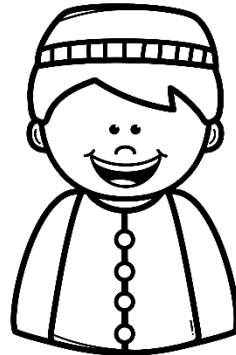

pen
glue
ruler
crayon

G

Is this list in ABC Order?



dress
catch
ant
ball

H

Pick 4 animals and put their names in ABC order.



I

Is this list in
ABC Order?

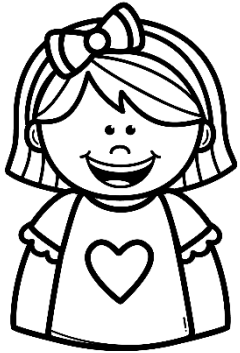

math
play
reading
science

J

Think of a
word to go in
the blank spot
on the list.

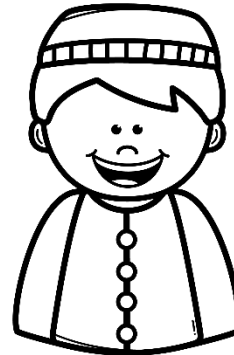

bat

mat
sat

K

Put these
words in
ABC Order.



cob
bed
hat
zip

L

Where would
"top" go on the
list below to
keep the words
in ABC order?



hop
mop
pop

ABC order TASK Cards

Name: _____

RECORDING SHEET

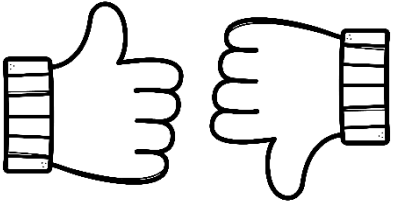
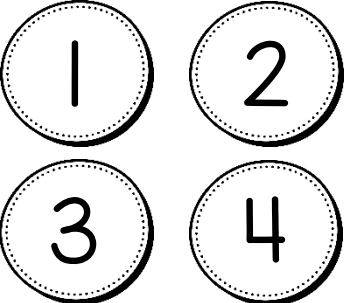
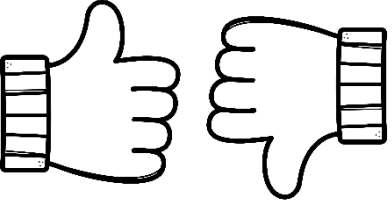
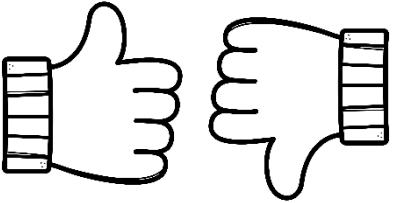
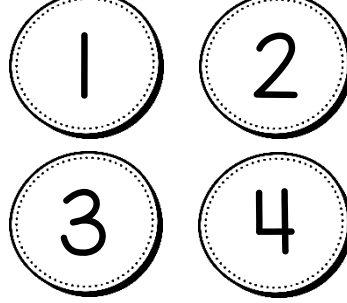
<p>A</p> <hr/> <hr/> <hr/> <hr/>	<p>B</p> 	<p>C</p> <hr/> <hr/> <hr/> <hr/>	<p>D</p> 
<p>E</p> <p>apple</p> <p>banana</p> <hr/> <p>mango</p>	<p>F</p> <hr/> <hr/> <hr/> <hr/>	<p>G</p> 	<p>H</p> <hr/> <hr/> <hr/> <hr/>
<p>I</p> 	<p>J</p> <p>bat</p> <hr/> <p>mat</p> <p>sat</p>	<p>K</p> <hr/> <hr/> <hr/> <hr/>	<p>L</p> 

August Literacy Activities

Decodable Reader

Kids can practice decoding CVC words and reading sight words in the decodable reader (3 levels included). There are 3 versions provided for each: one with illustrations and one with just text so students can add their own illustrations, and one in color.

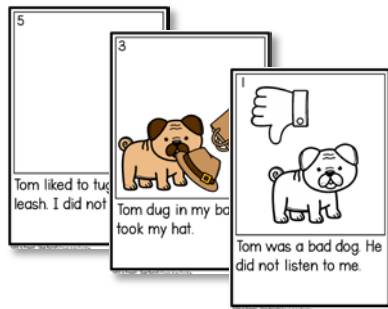

READING passage **CVC WORDS**

Name: _____ With Comprehension Questions

Directions: Read the passage three times. Then, answer the questions.

My Dog, Tom

Tom was a bad dog. He did not listen to me. When I told Tom to sit, he ran. When I told him to run, he sat. Tom dug in my bag. He took my hat. Tom liked to tug for food. He wanted to eat from Tom. Tom liked to tug on his leash. I did not like that. Tom dug up dirt in the garden. My neighbor got mad. Tom sat on my feet with dirty paws. I was so sad. Tom did not want me to be sad. He stopped being bad. Tom is not bad now. He is a good dog. I love Tom. He is _____

READING passage **CVC WORDS**

Name: _____ With Comprehension Questions

Directions: Read the passage three times. Then, answer the questions.

My Dog, Tom

Tom was a bad dog. He did not listen to me. When I told Tom to sit, he ran. When I told him to run, he sat. Tom dug in my bag. He took my hat. Tom liked to tug for food. He wanted to eat from Tom. Tom liked to tug on his leash. I did not like that. Tom dug up dirt in the garden. My neighbor got mad. Tom sat on my feet with dirty paws. I was so sad. Tom did not want me to be sad. He stopped being bad. Tom is not bad now. He is a good dog. I love Tom. He is the best pet I have ever met.

Questions

Who are the characters in the story?	Draw a picture of Tom being bad.
What is the problem in this story?	

Decodable Passages

These passages are a great way to assess reading fluency. After reading the story, students will complete a series of comprehension questions. Two levels of comprehension questions are provided.

CVC Word DECODABLE

Printing Instructions

Reader

1

Choose which reader you would like to print: the reader *without* pictures, the reader *with* pictures in black and white, or the reader *with* pictures in color.

2

Print the following pages front to back.

- For the reader *with* pictures (in B & W), print pages 94-99.
- For reader *with* pictures (in color), print pages 100-105.
- For the reader *without* pictures, print pages 106-111.

3

Stack the pages, fold in half, and secure with staples.

The End.

My Dog,
Tom

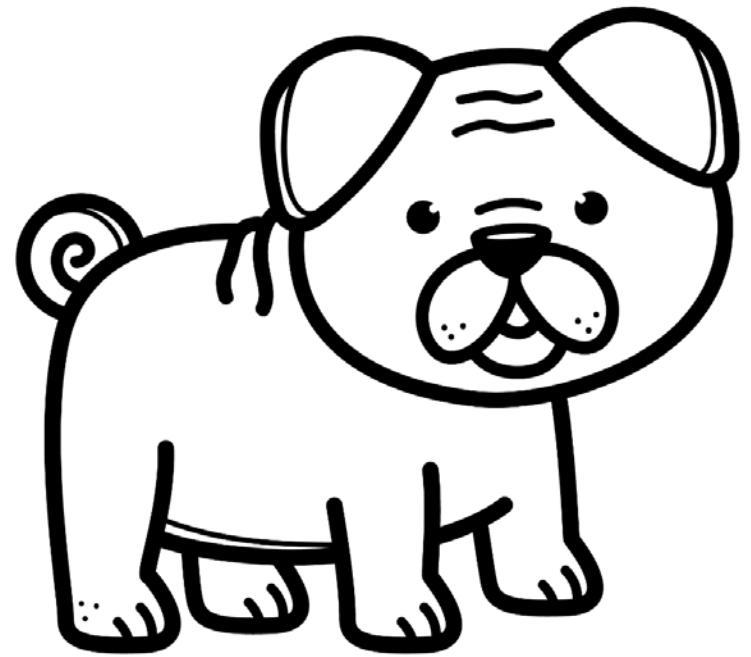

This Book Belongs to:

1

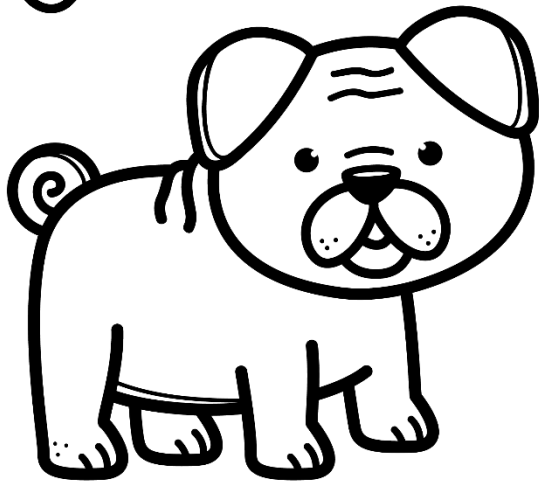
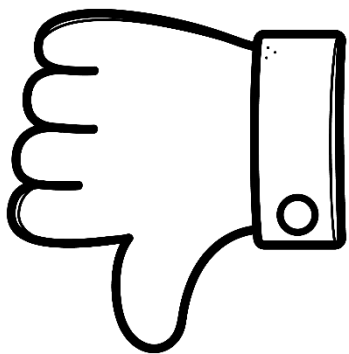

Tom was a bad dog. He did not listen to me.

10



I love Tom. He is the best pet I have ever met.

3

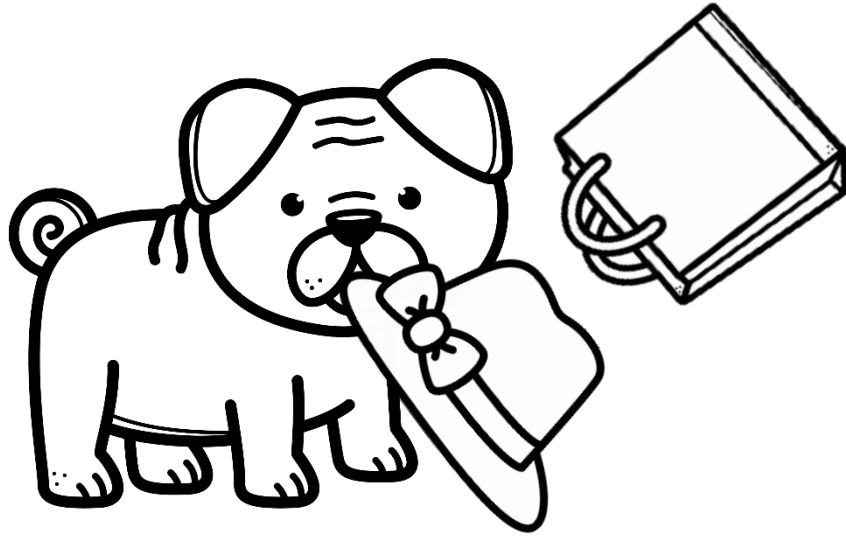

Tom dug in my bag. He took my hat.

8



Tom did not want me to be sad. He stopped being bad.

9

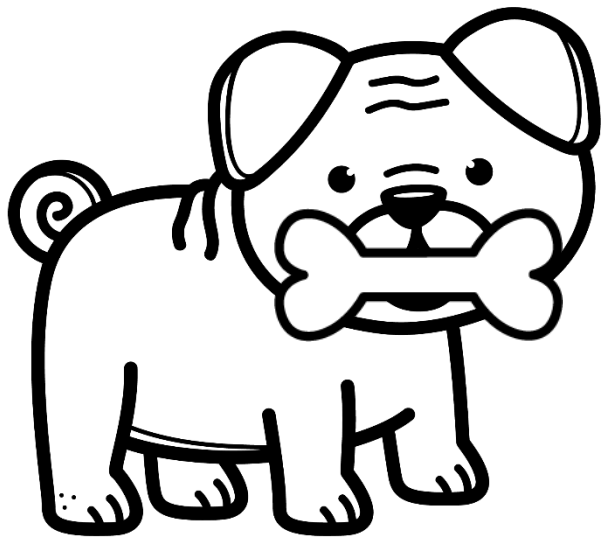

Tom is not bad now. He is a good dog.

2

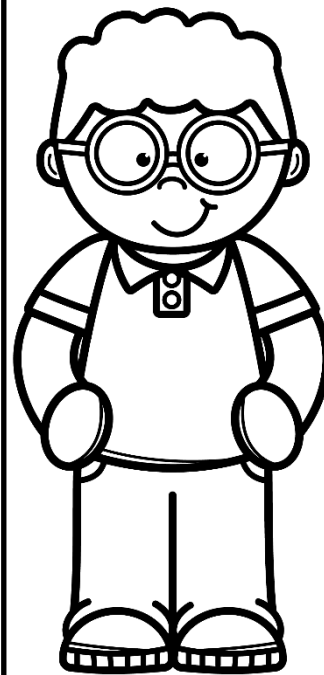

I said sit!

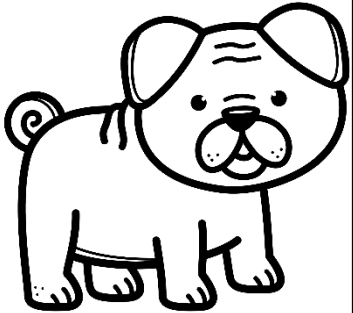

When I told him to sit, he ran. When I told him to run, he sat.

7

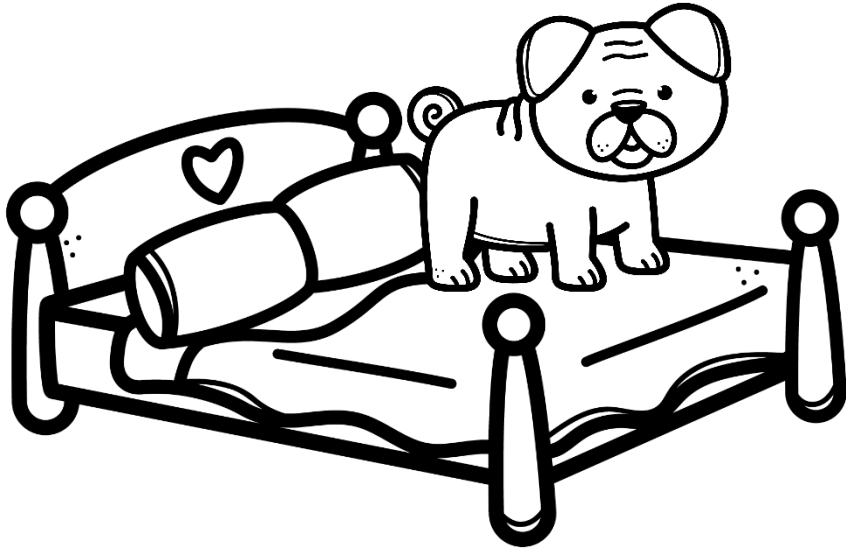

Tom sat on my bed
with dirty paws.
I was so sad.

4

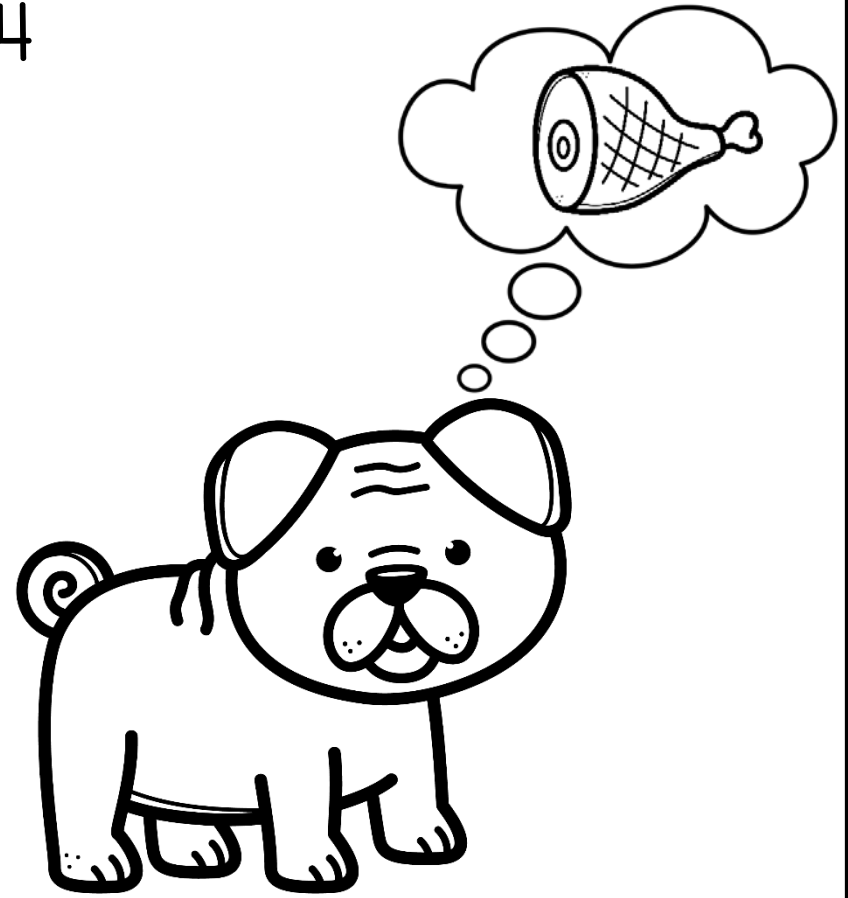

Tom liked to beg for
food. He wanted to
eat ham.

5

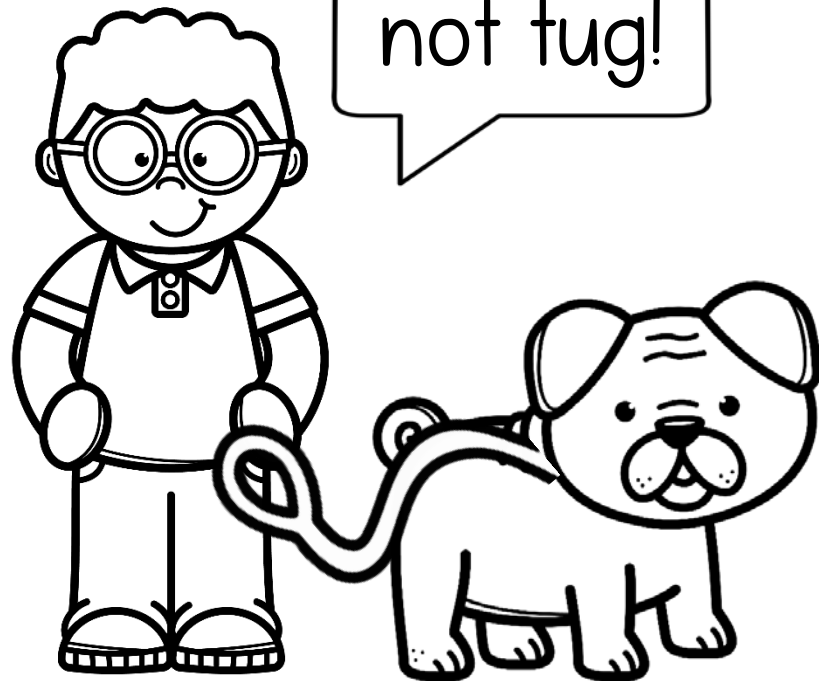

Tom, do not tug!

Tom liked to tug on his leash. I did not like that.

6

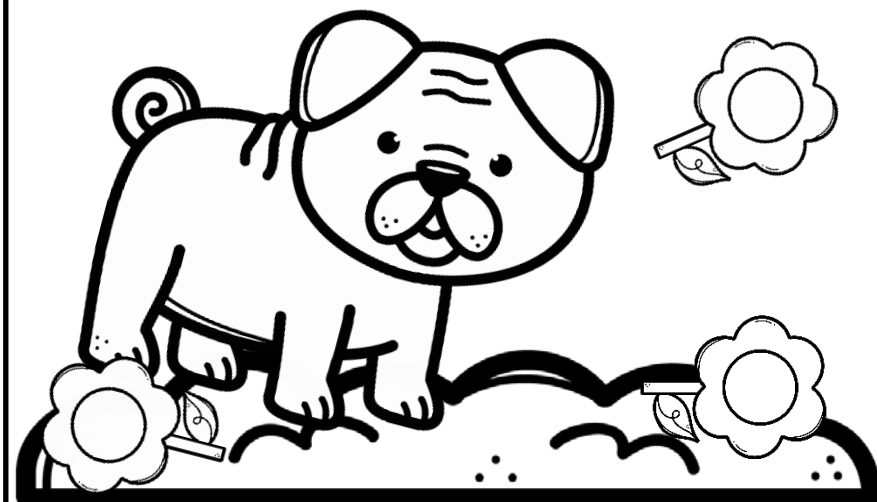

Tom dug up dirt in the garden. My mom got so mad.

The End.

My Dog,
Tom

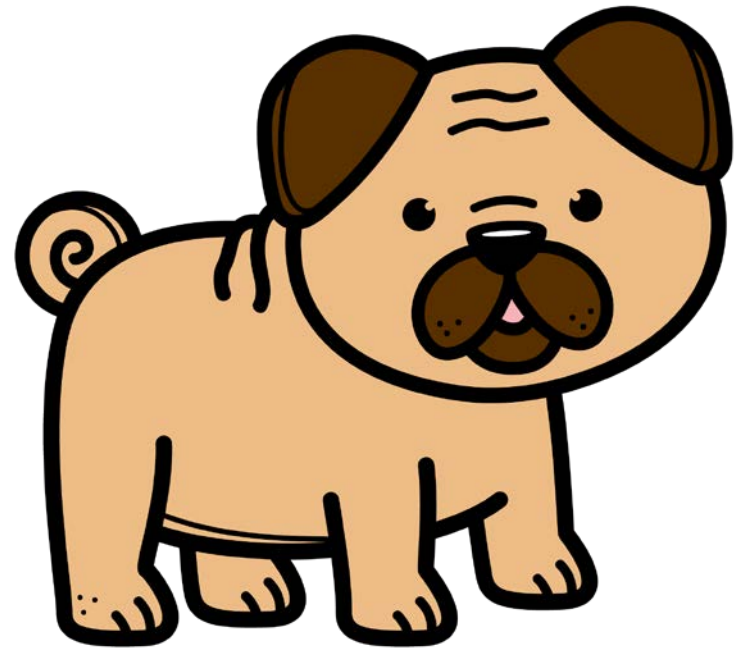

This Book Belongs to:

1

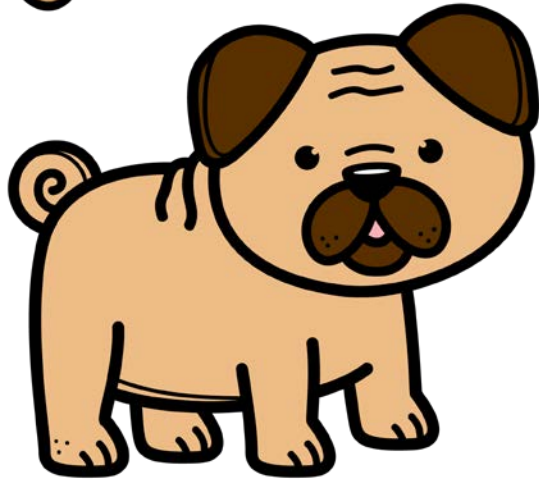
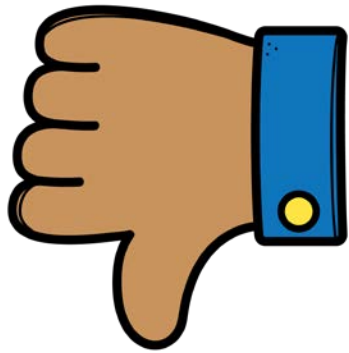

Tom was a bad dog. He did not listen to me.

10

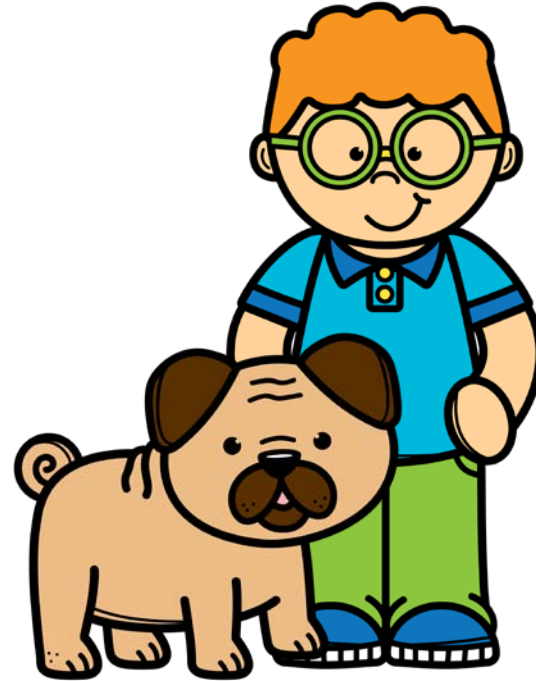

I love Tom. He is the best pet I have ever met.

3

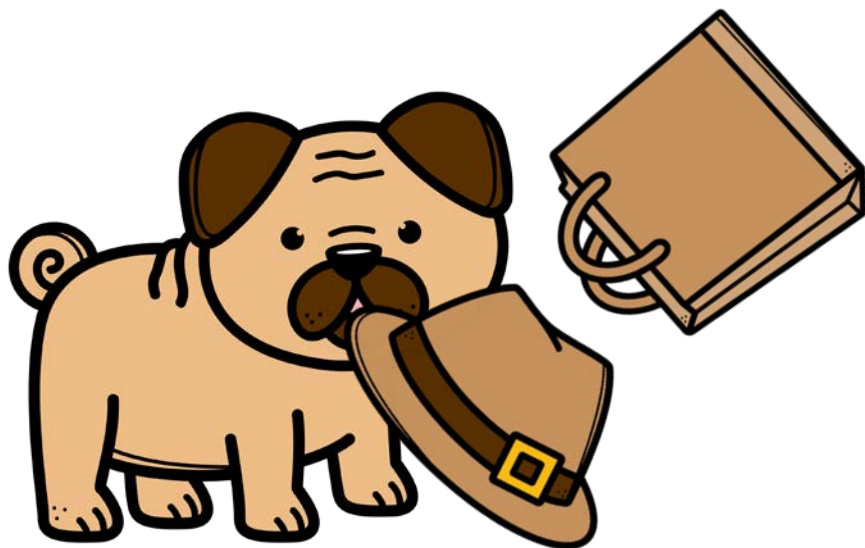

Tom dug in my bag. He took my hat.

8



Tom did not want me to be sad. He stopped being bad.

2

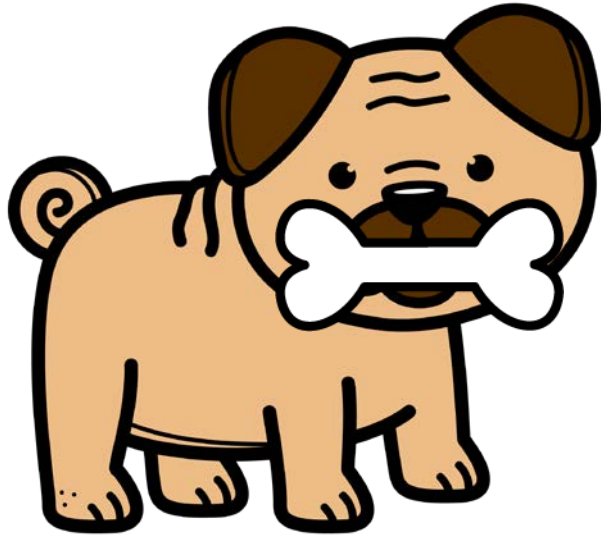

Tom is not bad now. He is a good dog.

9



I said sit!



When I told him to sit, he ran. When I told him to run, he sat.

7



Tom sat on my bed
with dirty paws.
I was so sad.

4

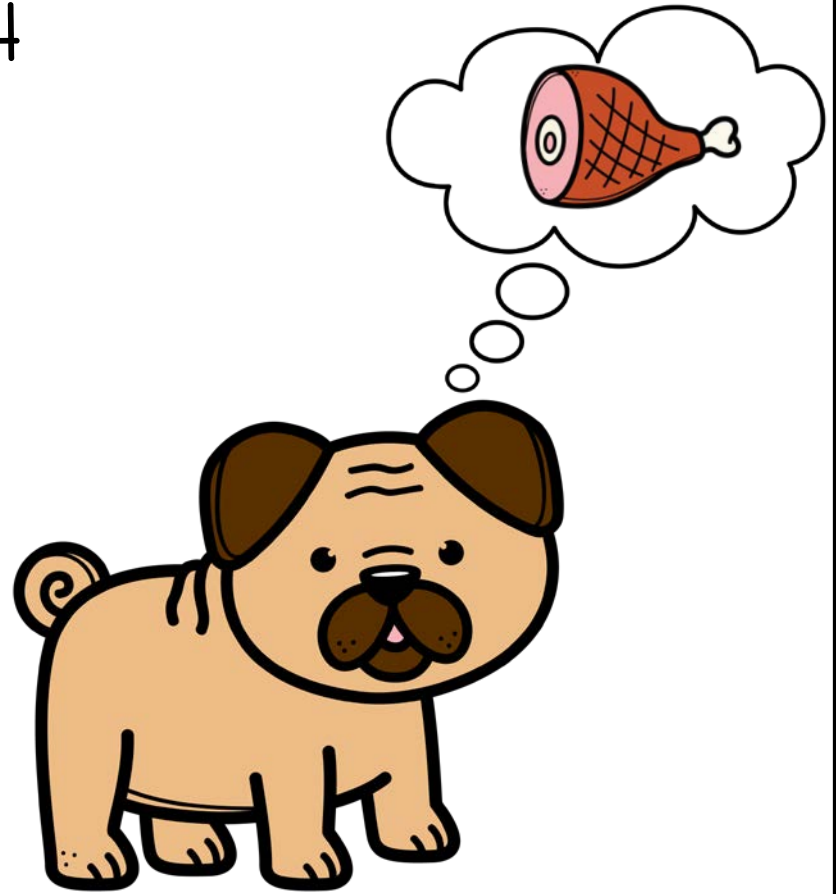

Tom liked to beg for
food. He wanted to
eat ham.

5

Tom, do not tug!

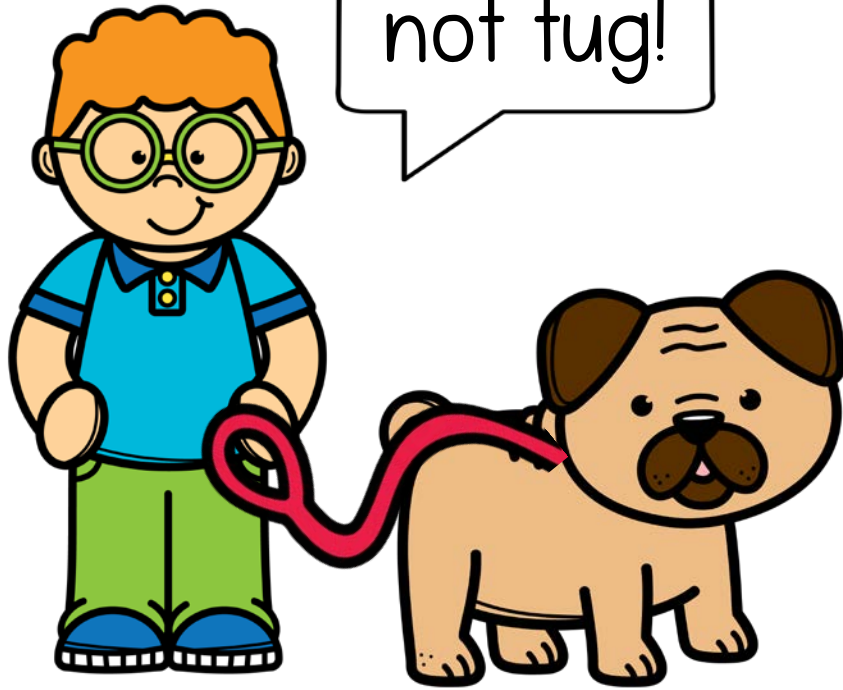

Tom liked to tug on his leash. I did not like that.

6



Tom dug up dirt in the garden. My mom got so mad.

My Dog, Tom

The End.

This Book Belongs to:

1

Tom was a bad dog. He did not listen to me.

10

I love Tom. He is the best pet I have ever met.

3

Tom dug in my bag. He took my hat.

8

Tom did not want me to be sad. He stopped being bad.

2

Tom is not bad now. He is a good dog.

9

When I told him to sit, he ran. When I told him to run, he sat.

7

Tom sat on my bed
with dirty paws.
I was so sad.

4

Tom liked to beg for
food. He wanted to
eat ham.

5

Tom liked to tug on his leash. I did not like that.

6

Tom dug up dirt in the garden. My mom got so mad.

READING passage

CVC WORDS

Name: _____ With Comprehension Questions

Directions: Read the passage three times. Then, answer the questions.

My Dog, Tom

Tom was a bad dog. He did not listen to me. When I told him to sit, he ran. When I told him to run, he sat. Tom dug in my bag. He took my hat. Tom liked to beg for food. He wanted to eat ham. Tom liked to tug on his leash. I did not like that. Tom dug up dirt in the garden. My mom got so mad. Tom sat on my bed with dirty paws. I was so sad. Tom did not want me to be sad. He stopped being bad. Tom is not bad now. He is a good dog. I love Tom. He is the best pet I have ever met.

Questions

1. Who are the characters in the story? _____
2. What is the problem in this story? _____
3. What is one bad thing Tom did? _____
4. Why did Tom start being good? _____

READING passage

CVC WORDS

Name: _____ With Comprehension Questions

Directions: Read the passage three times. Then, answer the questions.

My Dog, Tom

Tom was a bad dog. He did not listen to me. When I told him to sit, he ran. When I told him to run, he sat. Tom dug in my bag. He took my hat. Tom liked to beg for food. He wanted to eat ham. Tom liked to tug on his leash. I did not like that. Tom dug up dirt in the garden. My mom got so mad. Tom sat on my bed with dirty paws. I was so sad. Tom did not want me to be sad. He stopped being bad. Tom is not bad now. He is a good dog. I love Tom. He is the best pet I have ever met.

Questions

Who are the characters in the story?

What is the problem in this story?

Draw a picture of Tom being bad.

THANK YOU!

Thank you so much for downloading this resource! I appreciate your interest and hope that the resource is exactly what you are looking for. Remember to leave feedback for credits towards future purchases on TpT. I am always happy to answer any and all questions or concerns regarding this resource. Please email me at elyse@proudtobeprimary.com.



Terms of Use

Purchase or download of this resource entitles the purchaser/downloader to **single classroom use only**. Duplication for staff, schools, or districts is strictly prohibited. Copying, posting, or selling any part of this resource is a violation of the Digital Millennium Copyright Act (DMCA). The purchaser is entitled to upload the digital portion of the resource to a secure, password protected online portal (Seesaw, Google Classroom, Microsoft Teams) for use with students ONLY. All materials are copyrighted © Proud to be Primary - Elyse Rycroft

Let's Stay Connected!

Join my
Email List
for proud primary
Teachers

Join our
Community
for proud primary
Teachers



Fonts & Clipart



Learn More About TEACHING PHONICS

Find simple and fun ways to teach phonics with hands-on activities and worksheets.

CLICK to learn more!



Literacy Resource Bundles for K-2



Click the images to see the different literacy bundles and resources to help you teach kids to read and spell!