



FES112

HIGH SECURITY

ELECTRIC CUSTODIAL STRIKE

INSTALLATION MANUAL

1. INTRODUCTION

The FES112 High Security Electric Custodial Strike was purposely designed for heavy duty high security applications where superior holding strength is required, such as detention centers, correctional facilities and the like.

The Strike works in conjunction with a heavy duty double throw deadlock or any other mechanical lock with a deadbolt dimension of 33-36mm fully extended throw, 10-17mm width and 57-59mm height. With a holding force in excess of 1000kg, multiple monitoring functions and 12-30VDC multi-voltage operation, the FES112 is a viable solution for either new or retrofit high security projects. The device is manufactured in FSH's Sydney operation and received a recent face-lift with additional door monitoring functions as well as dip-switch selection for Revision (REV) 2 and Revision (REV) 3 field-selectability.

2. FEATURES

Installed into the door frame, the FES112 operates in conjunction with a mechanical high security heavy duty Custodial type (or similar) deadlock. The extended dead bolt of the door lock is captured by the twin locking jaws of the FES112 Strike and is held securely until the strike receives an access or release signal from the access control system.

Monitoring functions include Door Position Reed Switch, Strike-Jaw/Lock Status monitoring and Strike Cover Plate Removed monitoring (Anti Tamper).

On operation of the FES112, the strike jaws are released through an Access Control signal and the door is ready to be pushed or pulled open with the mechanical door lock bolt still fully extended. The redesigned FES112 can be wired in a way that the jaws remain in the open position until the door lock returns into the FES112 Strike, closing the jaws to re-lock the door.

The Strike-Jaws cannot be manually pushed back into locked position as long as the door remains open (**provided the Door Position Reed Switch is used**). Once the door is closed and the Door Position Reed Switch senses the door in closed position the Strike-Jaws will relock.

3. Technical Data

PART NO.	FES112
FUNCTION	Power to Open (Fail Secure)
HOLDING FORCE	More than 1000kg
VOLTAGE/CURRENT	Multi Voltage 12-30VDC 12VDC, 1.5A current draw 24VDC, 0.75A current draw
MONITORING	Strike Jaws Door Lock Bolt Status Sensor Door Position Reed Switch Strike Plate Removed (Anti-Tamper)
TEMPERATURE RANGE	-20C to +60C
LOCK DEAD BOLT DIMENSION	Fully extended = 33-36mm Width = 10-17mm Height = 57-59mm

4. Dimensions

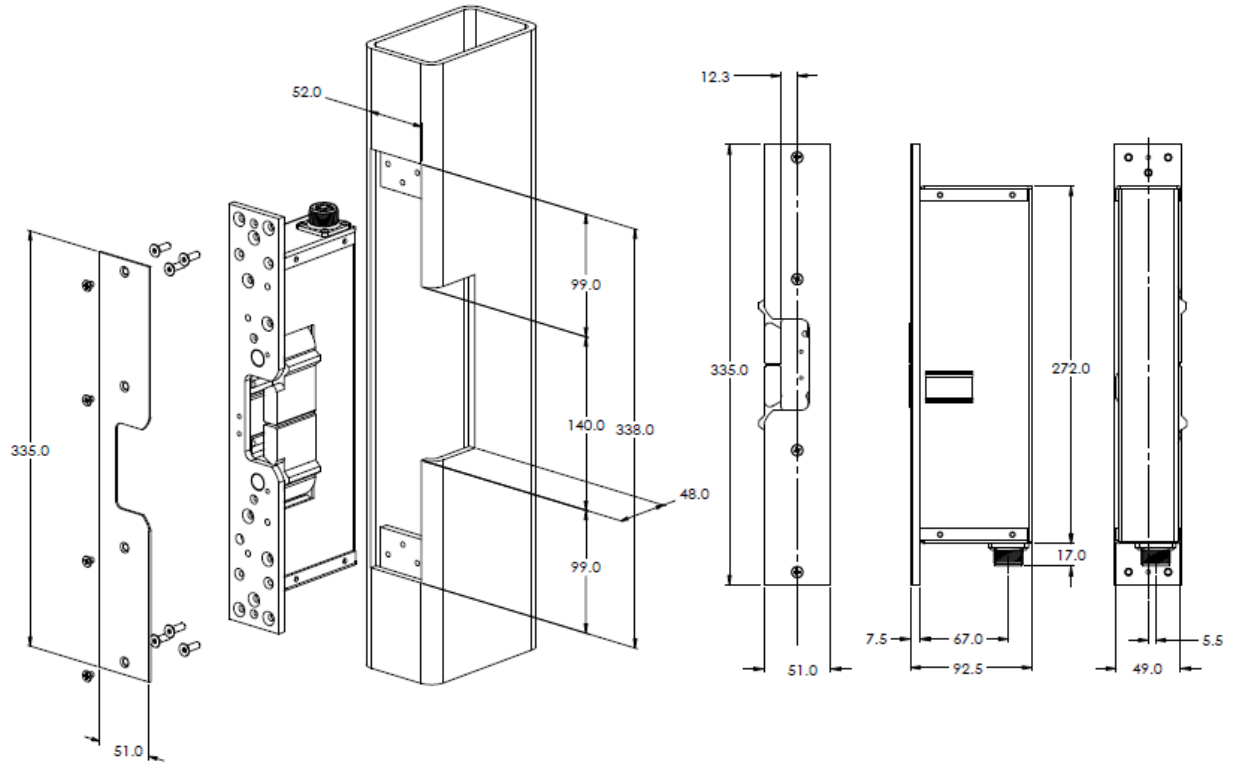

5. Switching from Revision REV 3 to REV 2

The FES112 comes in Revision REV 3 setting as factory default. If the Revision REV 2 setting is required, please remove the black rubber grommet and change the switch (1) from REV 3 over to REV 2.

The door status sensor/tongue sensor is switched off as factory default and can be activated with the dip-switch (2) shown in the picture.

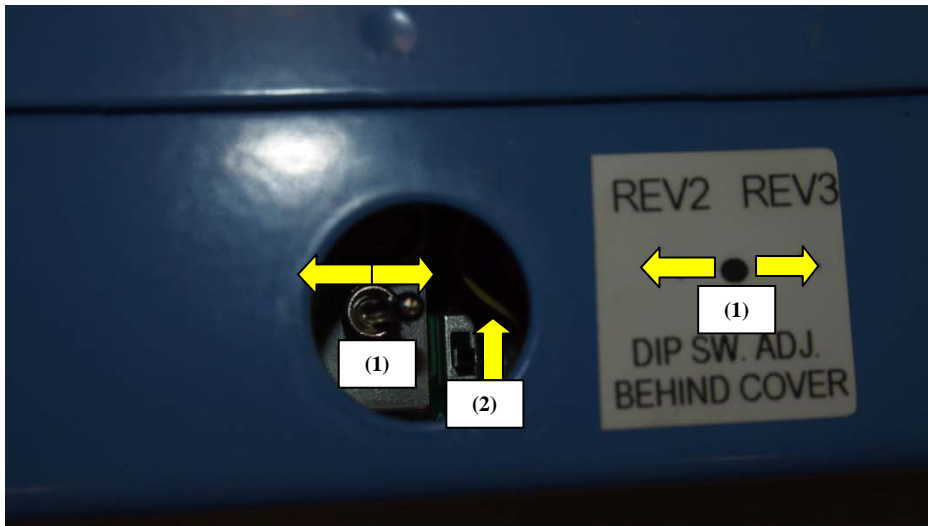

6. Wiring of the FES112 (Refer to Wiring Diagram)

The FES112 can be wired in two different ways.

1. Power is provided through position **A**(12-30v) and **B**(0v) to operate the strike (see wiring diagram below). No monitoring is involved.
2. The FES112 can be wired in such a way that the jaws cannot be closed unless the door locking bolt is in locked position. (anti tamper function). In this configuration power to connection **A** (12-30VDC) is always connected. The strike is operated by switching the negative through the Bolt /Reed monitoring. Normal strike operation is achieved by connecting connection **B** to negative.

Wiring for REV 2 using Bolt Switch and Door Position Reed Switch:

The negative is switched through position **E** which is the bolt sensor microswitch and the control reed switch, if fitted (see wiring diagram below). For the jaws to lock, the bolt microswitch has to be engaged and the door position reed switch, if fitted, has to detect the magnet in the door. If the door position reed switch is used, but the door position magnet is not strong enough (door gap > 8mm) to activate the control switch, the jaws will not lock.

The control reed switch function can be removed by disconnecting the door position reed switch ('Cntl') plug from the printed circuit board. For access to the printed circuit board please remove the blue back cover of the strike.

Wiring for REV 3 using Door Position Reed Switch:

The negative is switched through connection **F**, which is the door position reed switch. For the jaws to close the door position reed switch has to detect the magnet installed in the door. If the magnet is not strong enough (door gap >8mm) to activate the control switch the jaws will not lock.

7. Wiring Diagram Revision REV 3

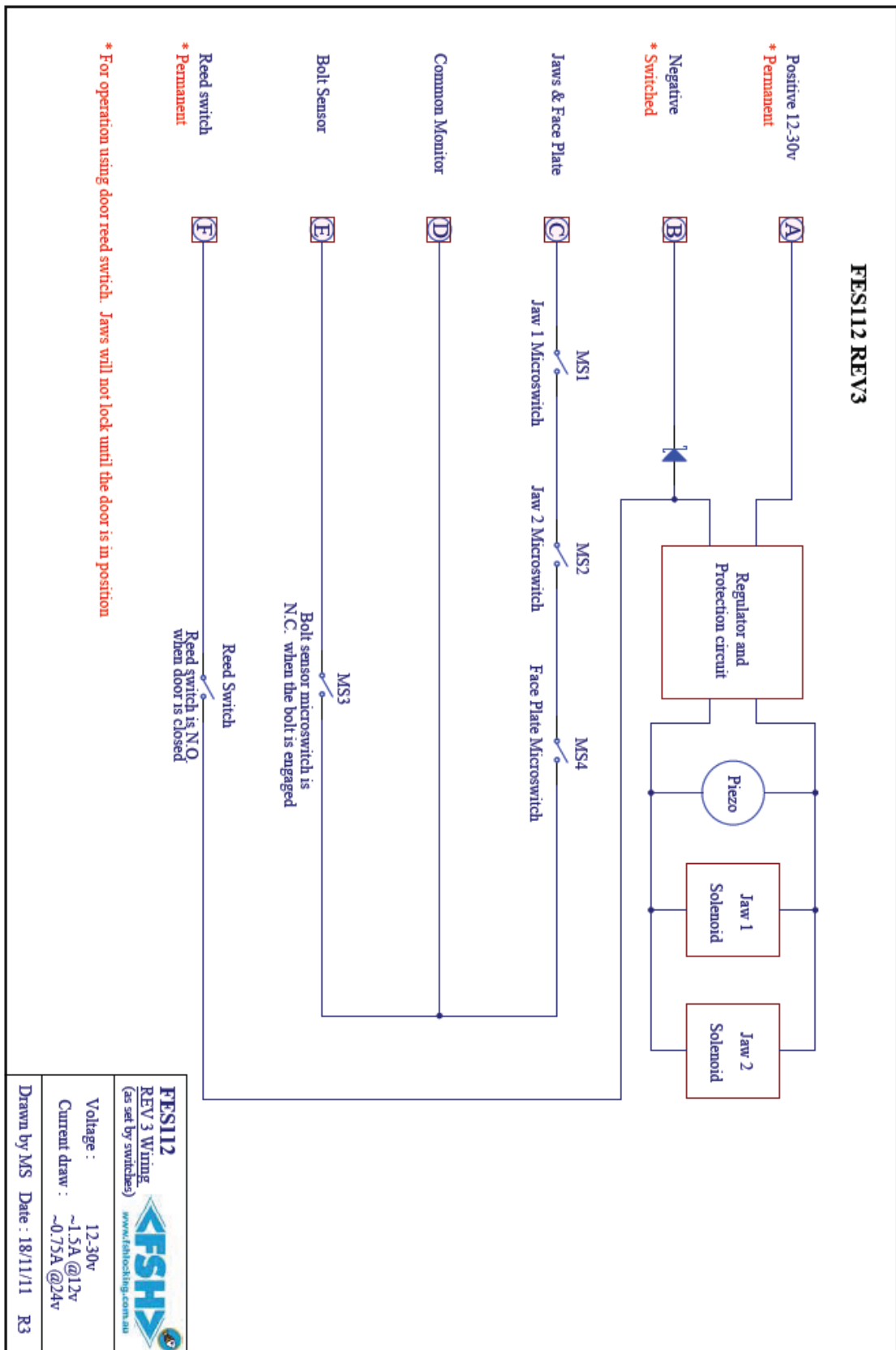

Wiring Diagram Revision REV 2

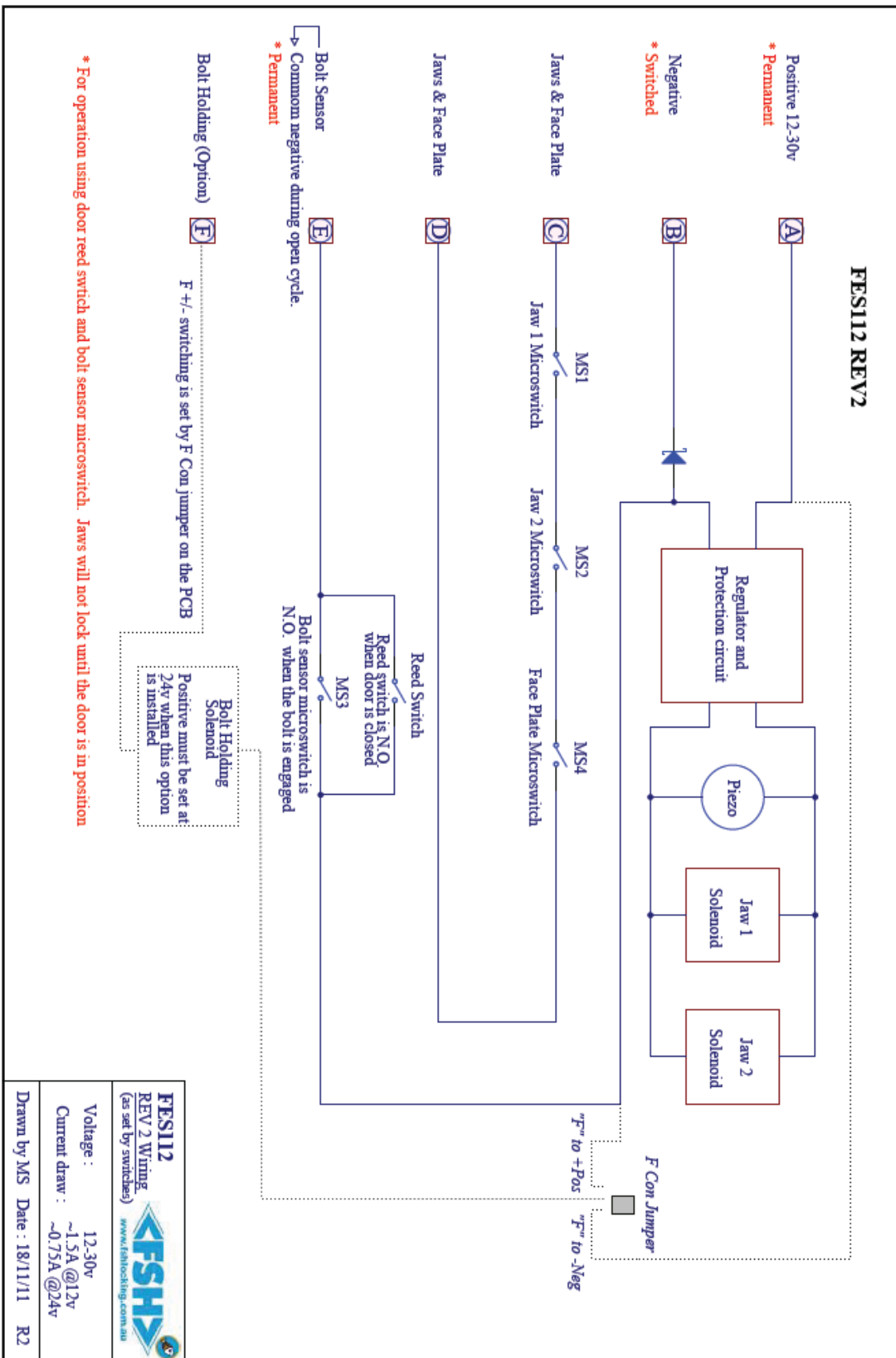

8. Connector and Door Position Magnet Installation

Connecting plugs as well as a door position Magnet are supplied with the device. The plugs are marked from A-F according to the wiring diagram.

The green sticker on top of the FSH logo on the face plate indicates the position of the door position Reed Switch of the strike. The door position Magnet has to be installed in the door in a way that it meets the position of the green sticker. Once installed, please remove green sticker. **The maximum door gap between door position Magnet and door position Reed Switch is 8mm.** The Reed Switch will not operate when the door gap is >8mm.

