

3FT CHESTER BED ASSEMBLY INSTRUCTIONS

Thank you for purchasing from The Oak Bed Store. As an independent family run company, customers such as yourself really make a big difference and we sincerely appreciate it.

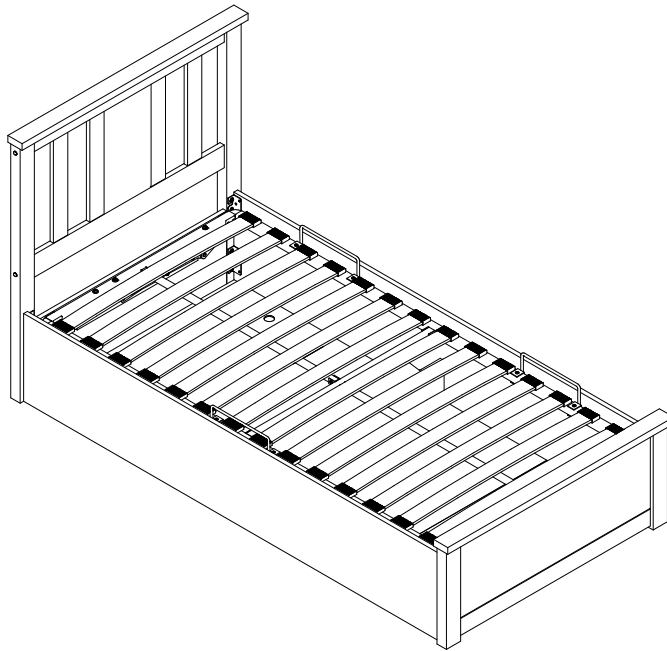

We hope you are delighted with your purchase, however if you have any further queries or concerns, please don't hesitate to contact us by;









- . Email at help@theoakbedstore.co.uk
- . Telephone on 02393 552 550
- . Live Chat via our website

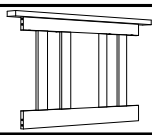
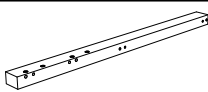
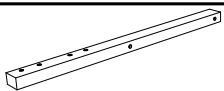

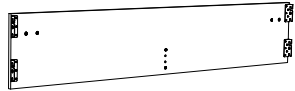
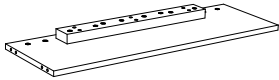

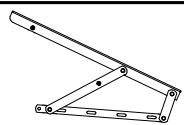
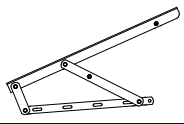

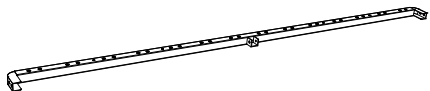
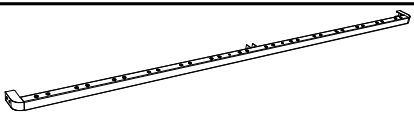
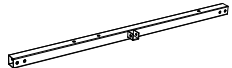
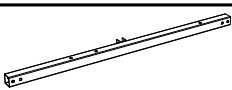
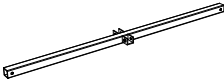







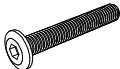

Please read the instructions carefully before assembling or use to ensure a safe and satisfactory operation of this product.

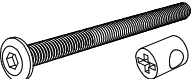
Please note:

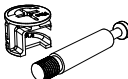
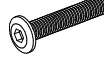
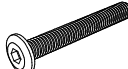
1. This product is heavy, it should be assembled as near as possible to the point of use.
2. Please do not drag the bed frame, always lift and reposition with 2 people to avoid personal injury as well as damage to the product.
3. Please do not discard any of the packaging until you have checked that you have all the parts and the pack of fittings.
4. DO NOT use any power tools as this may damage the frame and will invalidate any claim.
5. Periodically check all screws & fixings to ensure they are secure.
6. You will require a screwdriver and small mallet (not provided).
7. Please do not jump on this bed frame.
8. The fittings pack contains small parts, which should be kept away from children.

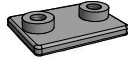
In the unlikely event that this product has missing or damaged parts, please call 02393 552 550 to obtain replacements.

PART LIST				
PART	DESCRIPTION		BOX	QTY
1	Headboard Frame		1/3	1
2	Left Wooden Post		1/3	1
3	Right Wooden Post		1/3	1
4	Footboard Frame		2/3	1
5	Side Rail - Left & Right		3/3	2
6	Back Storage Panel		2/3	1
7	Base Panel		1/3	4
8	Center Storage Panel		2/3	1
9	Left Hydraulic Base Support		2/3	1
10	Right Hydraulic Base Support		2/3	1
11	Hydraulic Pump		2/3	2
12	Back Side Bar		3/3	1
13	Front Side Bar		3/3	1
14	End Bar Left		3/3	1
15	End Bar Right		3/3	1
16	Center Bar		3/3	1
17	Middle Bar		3/3	2
18	Wood Slat		3/3	14

HARDWARE LIST (Found in box 3)				
PART	DESCRIPTION		BOX	QTY
A	M8 x 25mm JCBC Bolt		3/3	16
B	M8 x 15mm JCBC Bolt		3/3	8
C	M8 x 20mm JBCB Bolt		3/3	8
D	Base Handle		3/3	3
E	M6 x 40mm JCBC Bolt		3/3	8
F	M8 x 45mm RH Bolt c/w Hex Nut, Spribg Washer & Flat Washer		3/3	6
G	Single End Plastic Cap		3/3	28
H	ML-CB (Metal Corner Support)		3/3	2
I	M6 x 90mm JCBC Bolt + Barrel Nut		3/3	4
J	M8 x 30mm Wood Dowel		3/3	12
K	Wood Button		3/3	4
L	Mini Fix		3/3	8
M	M6 x 30mm JCBC Bolt		3/3	4
N	M6 x 45mm JCBC Bolt		3/3	8
O	Flat Bracket		3/3	4
P	Washer Bracket		3/3	4
Q	M6 Allen Key		3/3	1
R	M8 Allen Key		3/3	1
S	M12.8 Spanner		3/3	1
T	M14 Spanner		3/3	1

** You will also need a screw driver and small mallet (not provided).

Step 1: Attach the headboard frame (1) and back storage panel (6) to the left wooden post (2) and right wooden post (3). Secure the headboard frame using hardware parts I, J and K, then secure the back storage panel with hardware parts J and L.

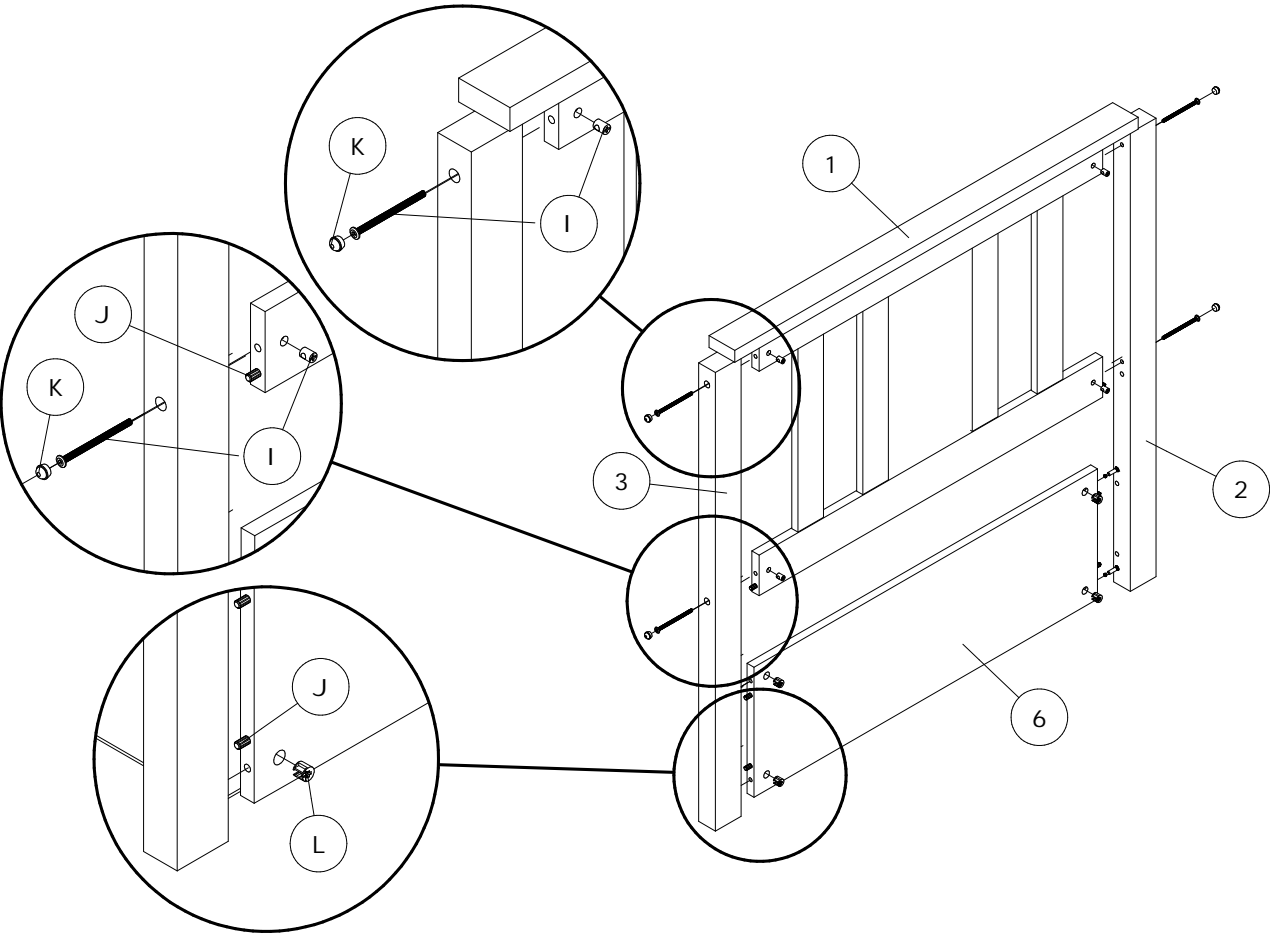

Step 2: Join together the left side rail and right side rail (5) with the centre storage panels (8) using hardware parts J and L.

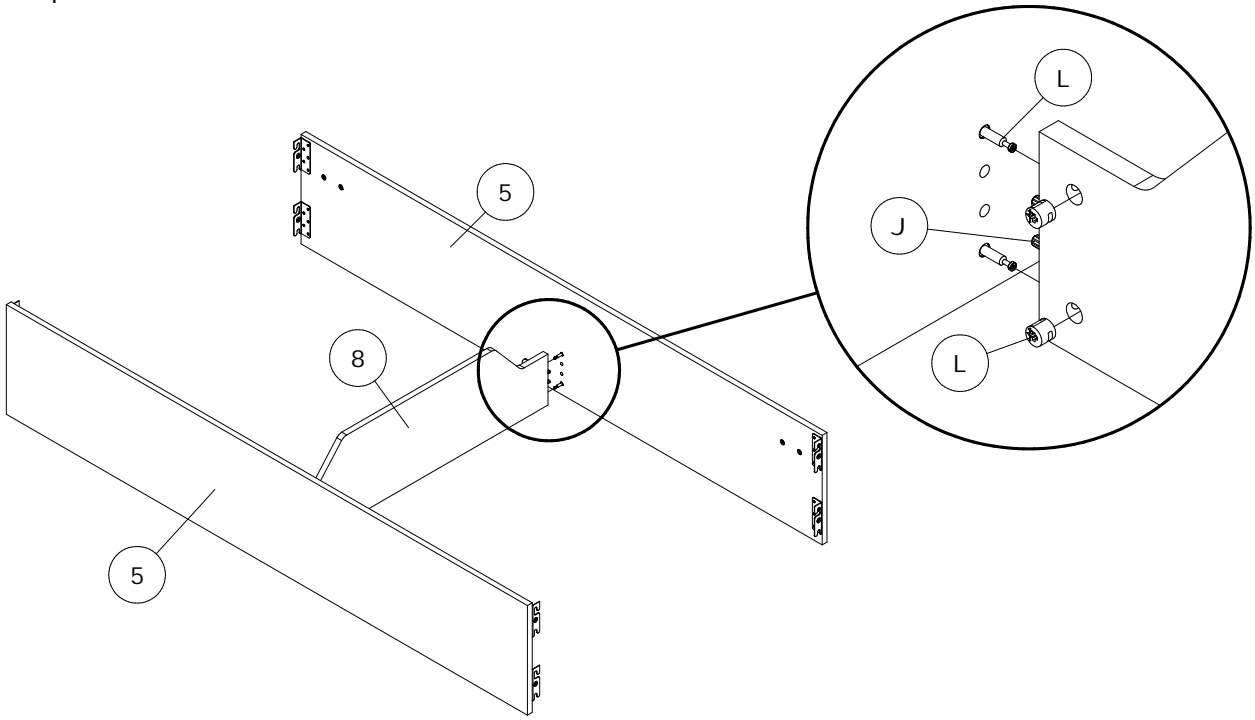

Step 3: Attach the headboard frame (1) and footboard (4) to the side rails using hardware part A.

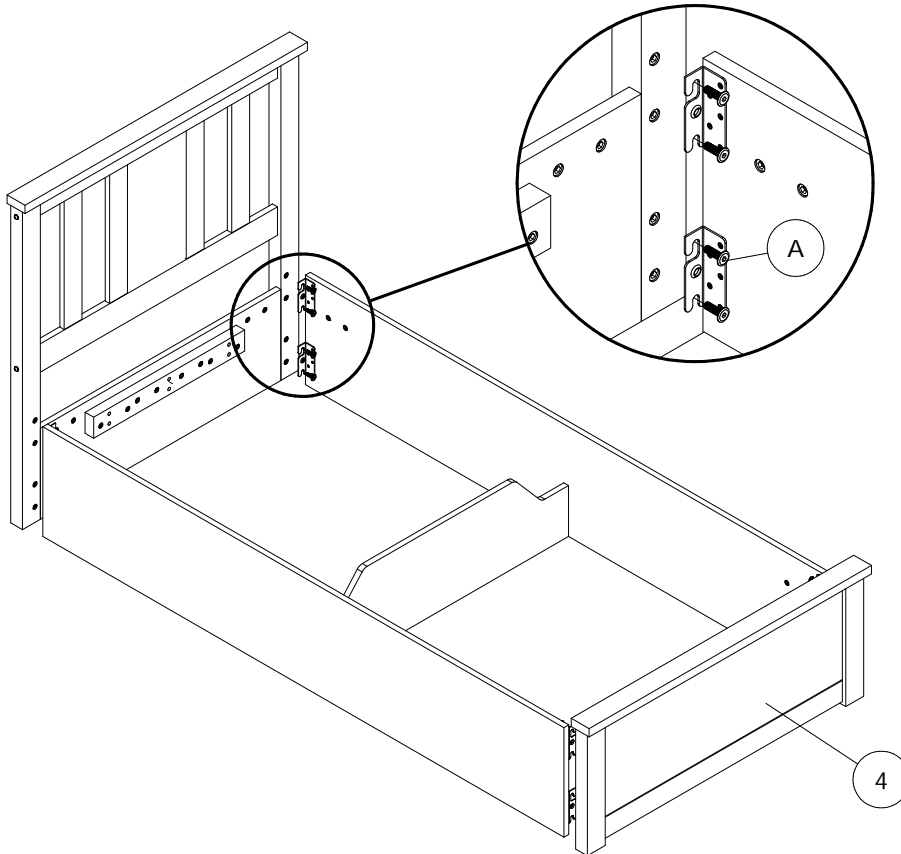

Step 4: Insert the base panel (7) to the position.

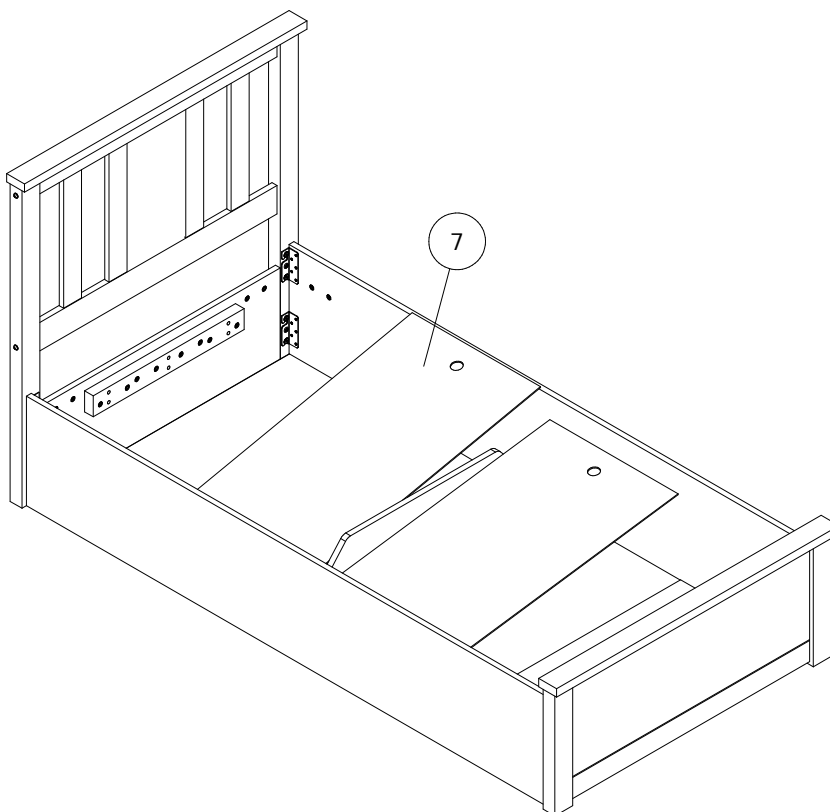

Step 5: Firstly, fix the hydraulic pump to each hydraulic base support as shown in diagram 5.1

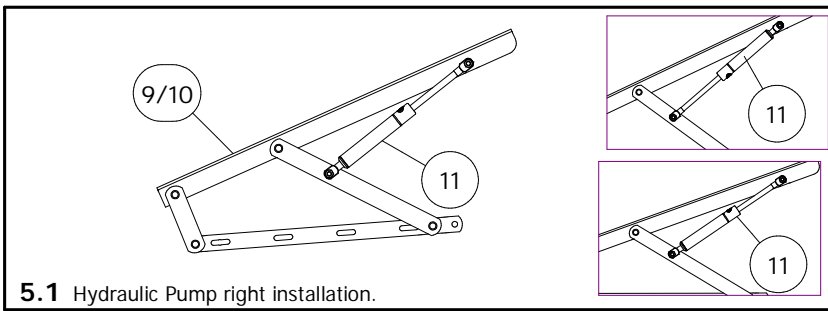

Next ensure your hydraulic opening side, locate your hydraulic base support through the JCBC holes L1, L2, L3 & L4 or R1, R2, R3 & R4 at the headboard and footboard as shown in diagram 5.2.

OPTION 1 (LEFT OPENING)

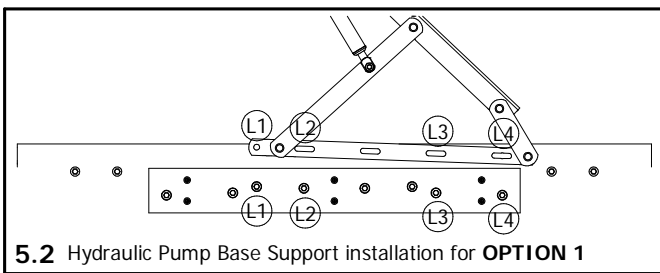

OPTION 2 (RIGHT OPENING)

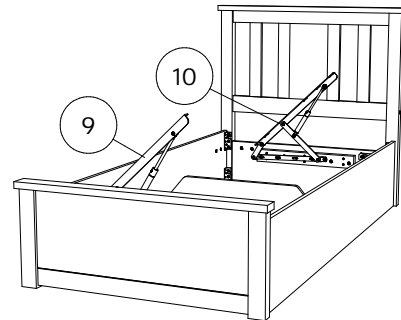
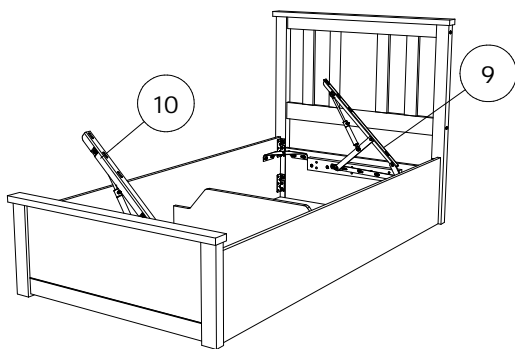
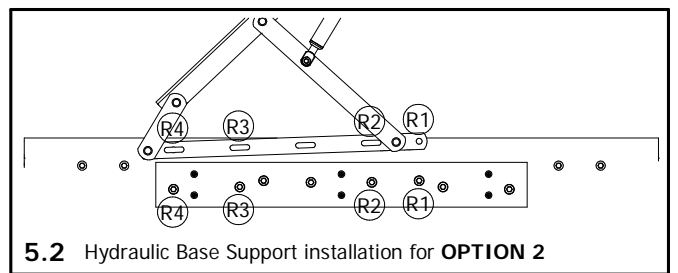

Make sure to fix bolts C at round end hole first (L1/R1) as shown in diagram 5.3 and do not tighten yet. Finally, fix all bolts and tighten all bolts as shown in diagram 5.4.

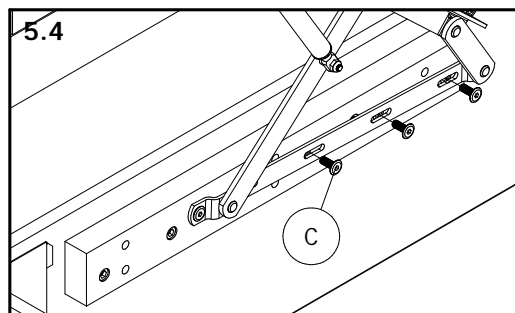
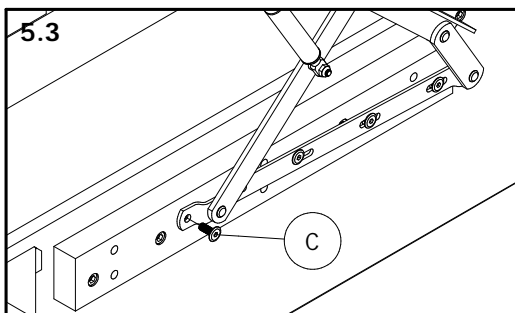

Step 6: Attach hardware part H using hardware parts B.

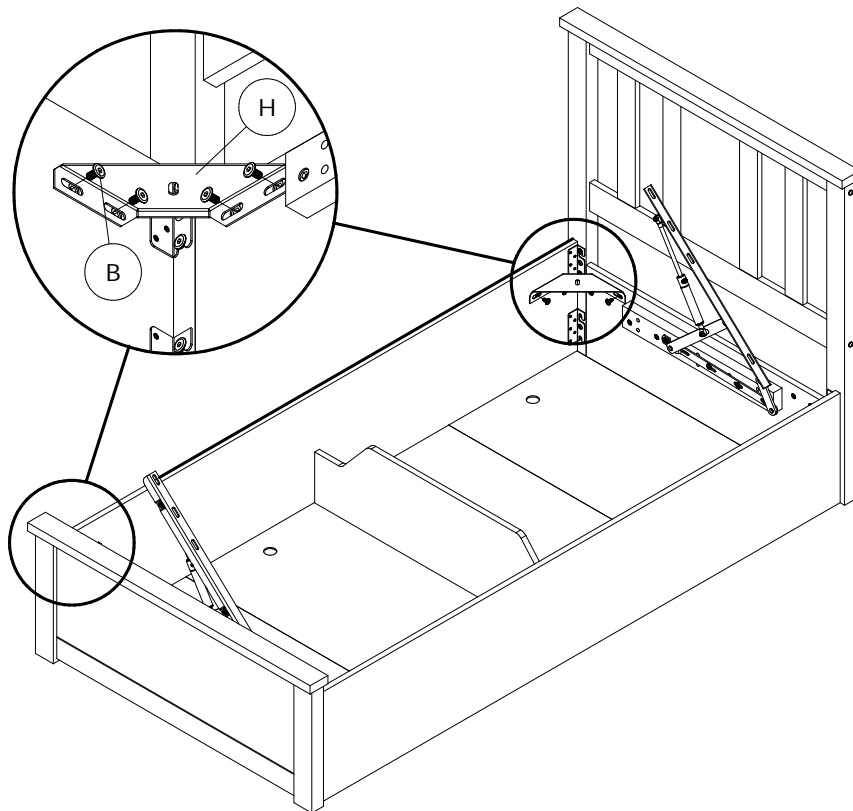

Step 7: Join together the front, back bed base (12)(13) and end bar left, right (14)(15) using hardware parts N, O and P. Attach parts (16) and (17) using hardware part E & M.

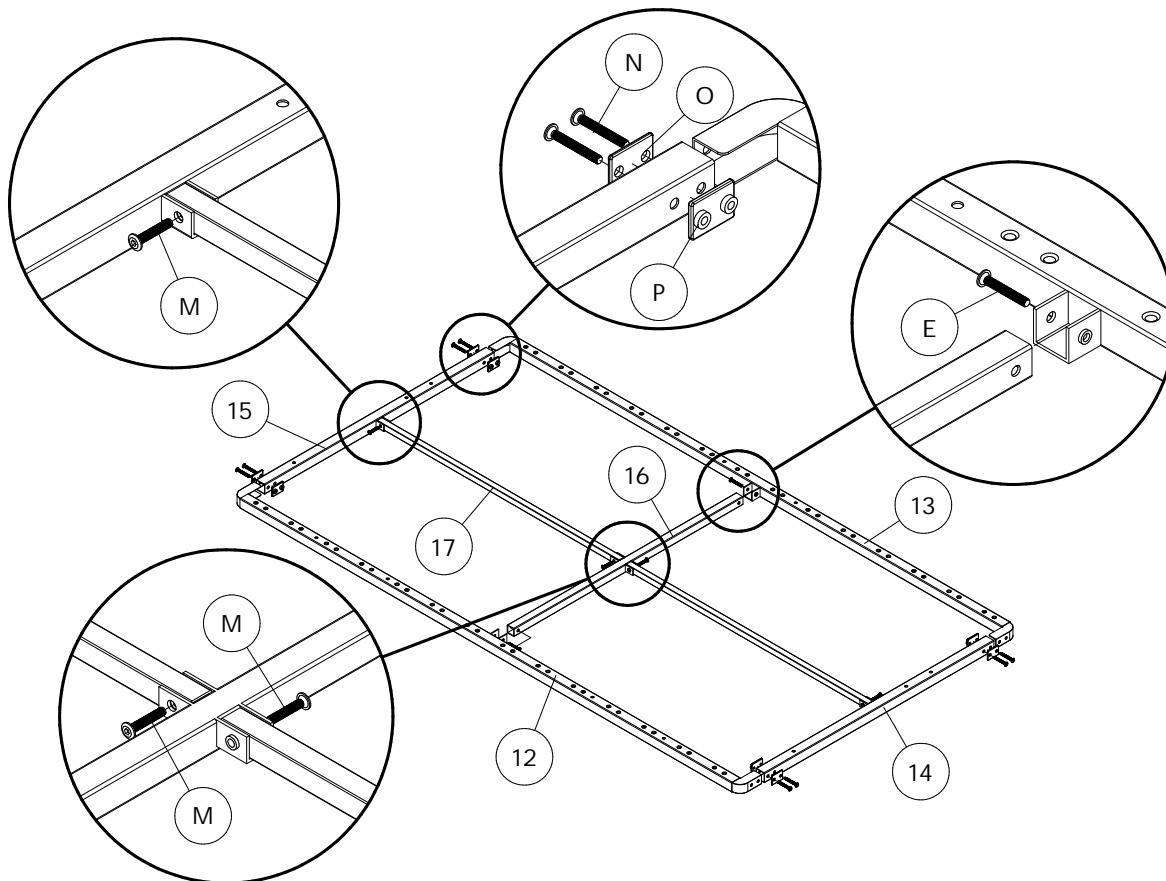

Step 8: Fit the slat cap G onto the spring slat (18) and insert into the pre-drilled holes. Please note you may need to press firmly into place. After that fix base handle to the bed base with bolts E as shown.

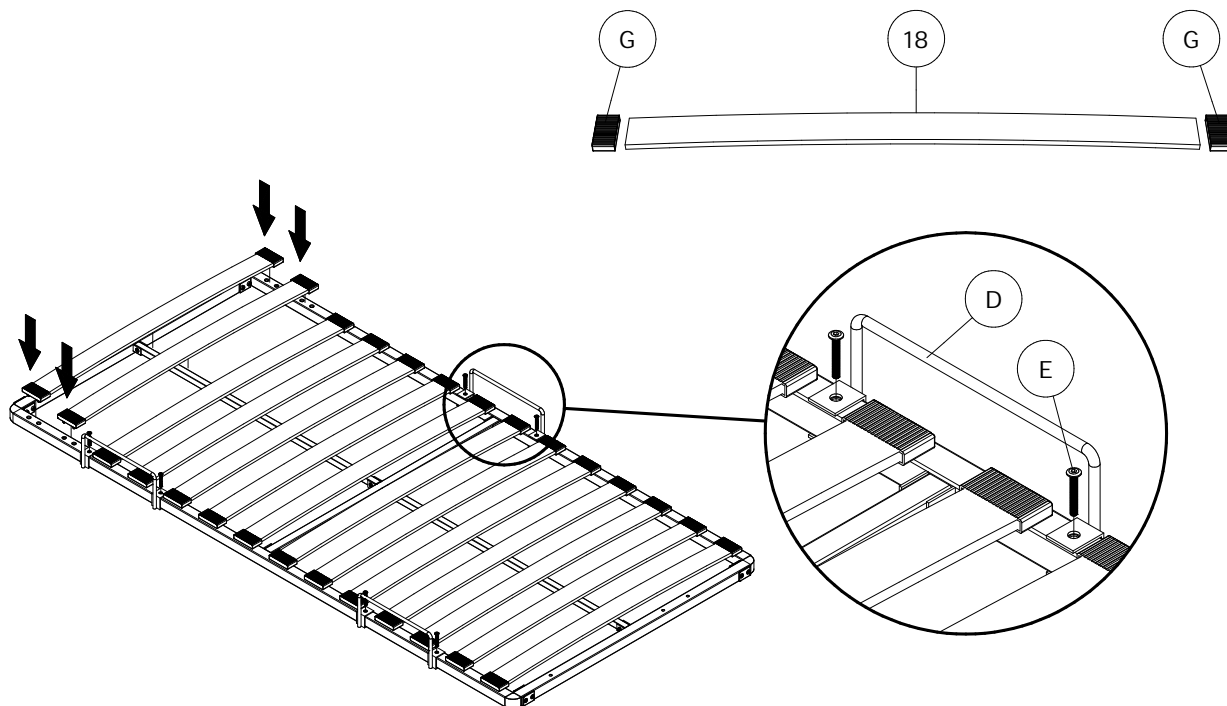

Step 9: Assemble the bed base on the left & right hydraulic frame and fix bolts starting from '1' to '3' as shown.

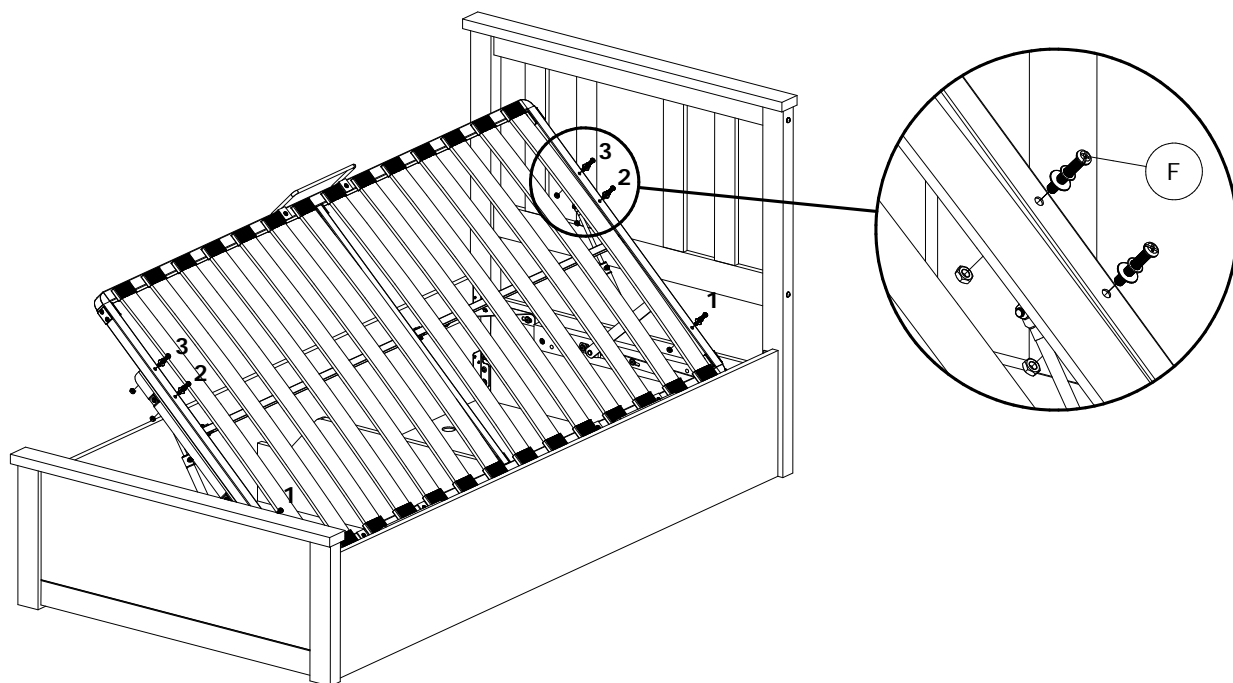

Step 10: Adjust the bed base, make sure that the distance with the side rail approximately 15mm to above. Tighten all bolts and screws.

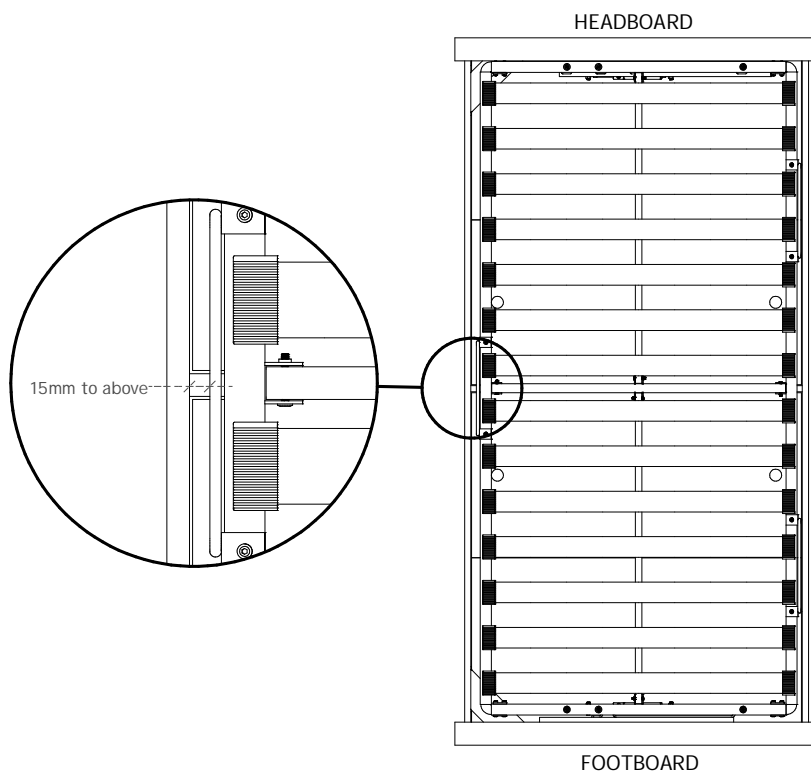

THE BED HAS BEEN FULLY ASSEMBLED

Option 1 (LEFT OPENING)

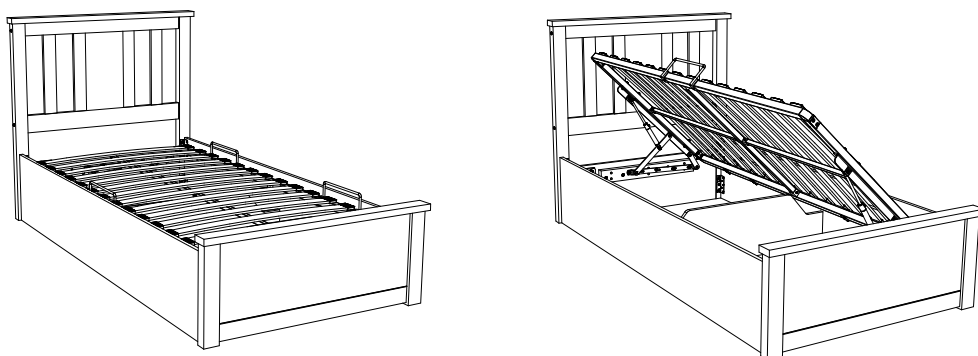

Option 2 (RIGHT OPENING)

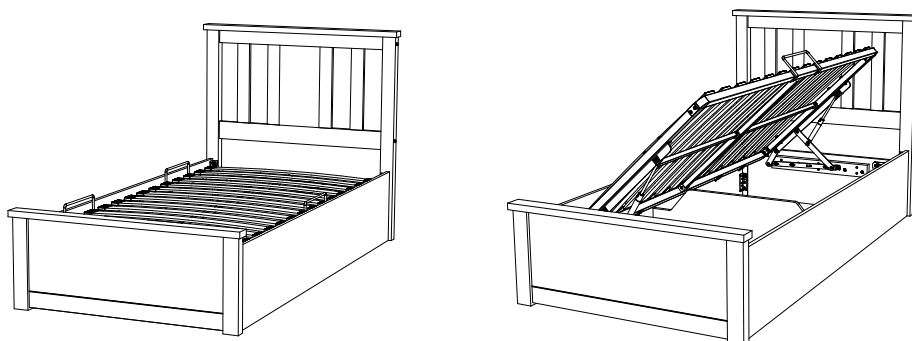

IMPORTANT NOTE

WHEN THE BED IS BUILT THE MATTRESS FRAME IS AT A 45 DEGREE ANGLE PLEASE PLACE THE MATTRESS ON THE BED.

PLEASE NOTE THAT THE WEIGHT OF THE MATTRESS IS REQUIRED TO HELP CLOSE THE BED.

TO LOWER THE SLEEPING PLATFORM STAND AT THE OPEN SIDE OF THE BED AND PUSH SHARPLY DOWNWARDS USING BOTH HANDS.

