

CHILGROVE 5FT BED ASSEMBLY INSTRUCTIONS

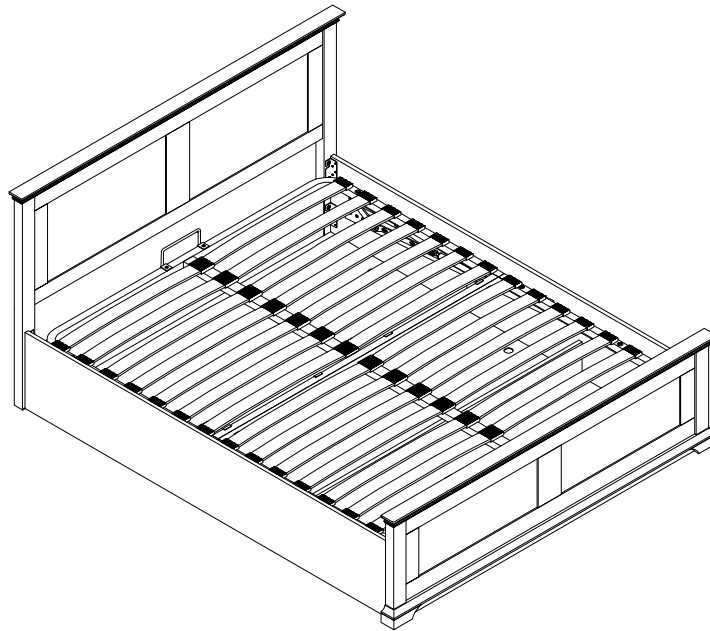

We hope you are delighted with your purchase, however if you have any further queries or concerns, please don't hesitate to contact us by;

- . Email at help@theoakbedstore.co.uk
- . Telephone on 02393 552 550
- . Live Chat via our website







Please read the instructions carefully before assembling or use to ensure a safe and satisfactory operation of this product.

Please note:

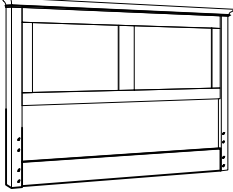
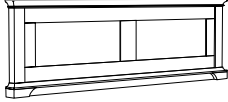
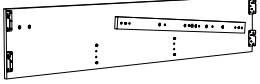
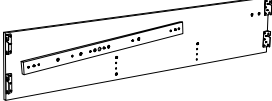



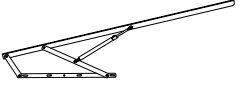
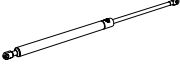
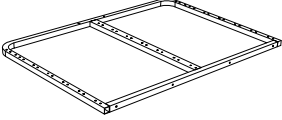
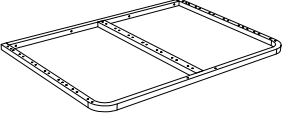





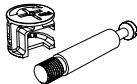

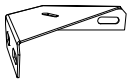
1. This product is heavy, it should be assembled as near as possible to the point of use.
2. Please do not drag the bed frame, always lift and reposition with 2 people to avoid personal injury as well as damage to the product.
3. Please do not discard any of the packaging until you have checked that you have all the parts and the pack of fittings.
4. DO NOT use any power tools as this may damage the frame and will invalidate any claim.
5. Periodically check all screws & fixings to ensure they are secure.
6. You will require a screwdriver (not provided).
7. Please do not jump on this bed frame.
8. The fittings pack contains small parts, which should be kept away from children.

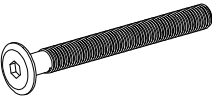
In the unlikely event that this product has missing or damaged parts, please call 02393 552 550 to obtain replacements.

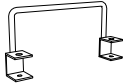
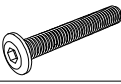
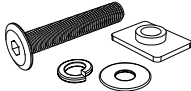
PART LIST

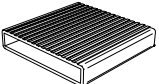
PART	DESCRIPTION	BOX	QTY
1	Headboard Frame 	1/5	1
2	Footboard 	2/5	1
3	Side Rail - Left 	4/5	1
4	Side Rail - Right 	4/5	1
5	Small Base Panel 	3/5	1
6	Large Base Panels 	3/5	3
7	Center Storage Panels 	3/5	2
8	Left Hydraulic Base Support 	4/5	1
9	Right Hydraulic Base Support 	4/5	1
10	Hydraulic Pumps 	4/5	2
11	Back Bed Base (1 x Hole Mounting) 	5/5	1
12	Front Bed Base (2 x Hole Mounting) 	5/5	1
13	Wooden Slats 	5/5	32

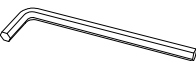
HARDWARE LIST (Found in box 4)

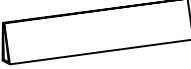
PART	DESCRIPTION		BOX	QTY
A	Cam Lock + Metal Screw Dowel		5/5	8
B	M8 x 30mm Wood Dowels		5/5	8
C	ML-CB (Metal Corner Support)		5/5	2
D	M8 x 16mm JCBB Bolt		5/5	34
E	M8 x 75mm JCBB Bolt		5/5	4
F	M8 Flat Washer		5/5	4
G	Base Nut		5/5	4
H	Base Handle		5/5	2
I	M6 x 40mm JCBC Bolt		5/5	4
J	M8 x 45mm JCBB Bolt c/w Nut Bracket, Spring & Flat Washer		5/5	6
K	Single End Plastic Cap		5/5	32
L	Double End Plastic Cap		5/5	16
M	M6 Allen Key		5/5	1
N	M8 Allen Key		5/5	1
O	M12.8 Spanner		5/5	1
P	Rubber Stopper		5/5	2

** You will also need a screw driver (not provided).

Step 1: Attach the Left and Right Side Rails (Parts 3 & 4) to the Centre Storage Panels (Parts 7) and tighten fully using Hardware (A & B).

- Ensure the Left and Right Side Rails are positioned correctly. Insert Metal Screw Dowel (A) and tighten fully using a Screwdriver. Insert Wooden Dowels (B) and Cam Lock (A) into the Centre Storage Panels (7). Attach both Centre Storage Panels to one of the side rails and tighten Cam Lock (A) fully using a screwdriver taking care not to overtighten. Please repeat this step for the other side.

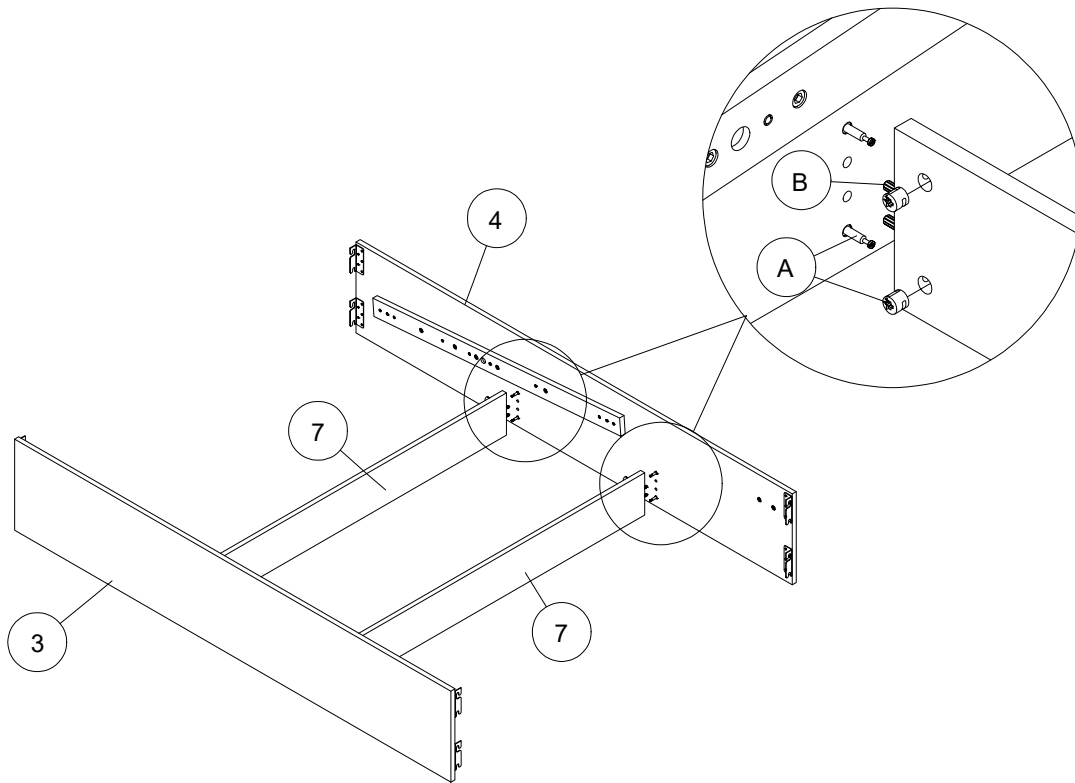

Step 2: Attach the Headboard Frame (Part 1) to the Side Rails and tighten using Hardware (D & N). Please repeat this step and attach the Footboard (Part 2).

- Line up the Headboard to the Side Rails and Insert M8 x 16mm Bolt (D) and fully tighten using M8 Allen Key (N). Please repeat this step to attach the Footboard.

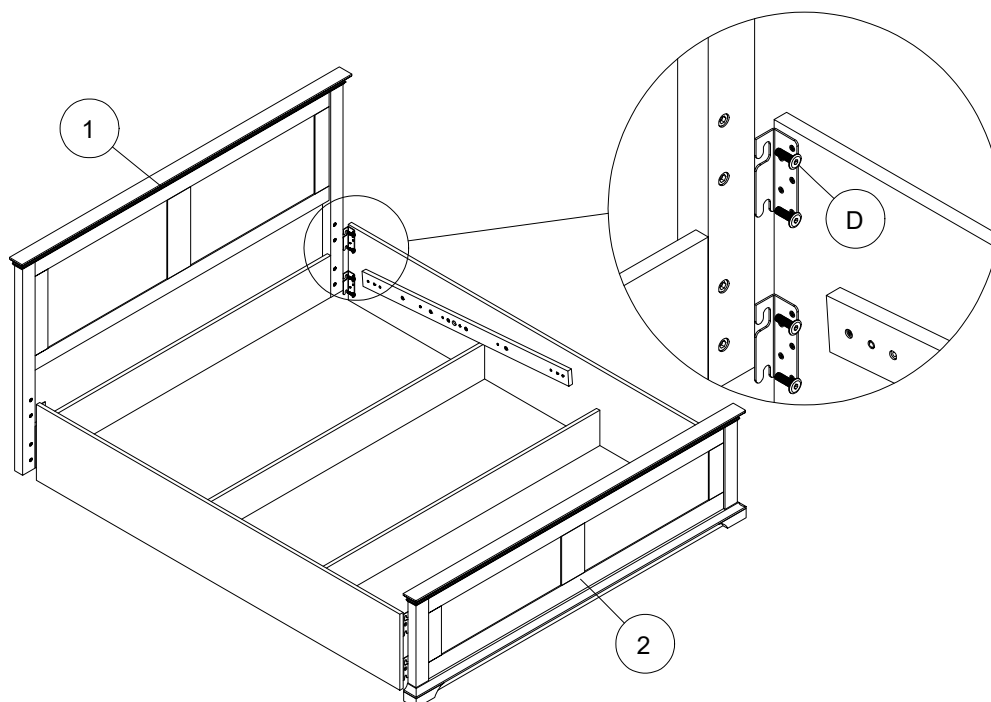

Step 3: Attach the Metal Corner Support (C) to the Footboard (2) and Side Rails using hardware (D & N).

- Place Metal Corner Support (C) to the Footboard (2) and Side Rails. Insert M8 x 16mm Bolt (D) and finger tighten. Ensure all corners are properly square (IE – At right angles) then fully tighten Bolt (D) using M8 Allen Key (N).

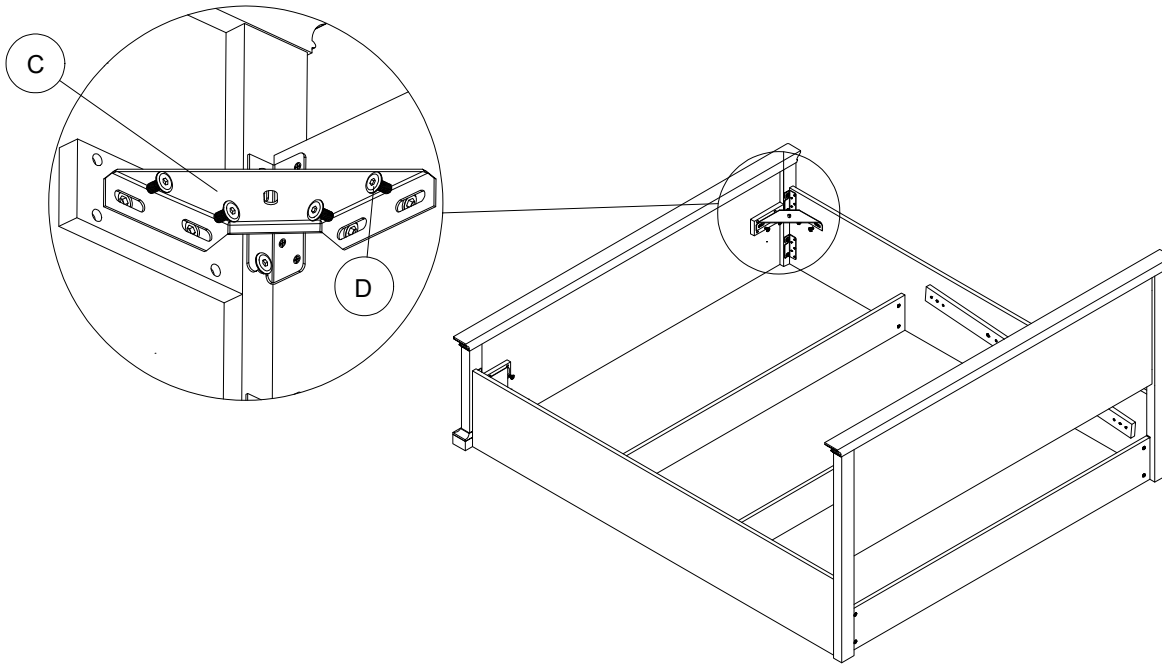

Step 4: Attach both Hydraulic Base Supports (8 & 9) to the Side Rails and tighten using hardware (D & N). Fix the Hydraulic Pump (10) to the Hydraulic Base Supports (8 & 9).

- Attach the Left Hydraulic Base Support (8) to the Left Side Rail. Tighten using M8 x16mm Bolt (D) and M8 Allen Key (N). Please ensure you insert the centre bolt first to ensure proper alignment and proceed to fit the remaining bolts.
- Remove the two pre-fitted nuts from the Hydraulic Base Support (8). Attach the Hydraulic Pump (10) to the Hydraulic Base Support (8) and re-apply the nuts and tighten fully with the Spanner (O). Refer to diagram 6.3 for the correct orientation of the Hydraulic Pump (10). Please repeat this step for the other side.

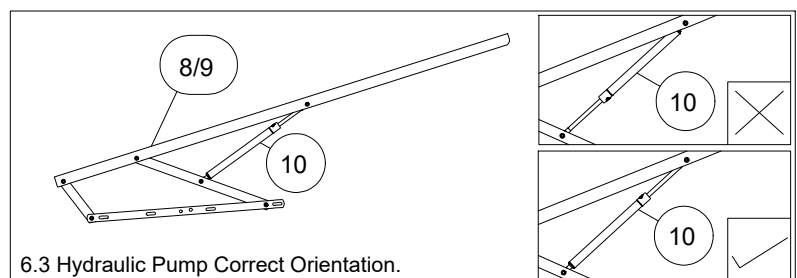
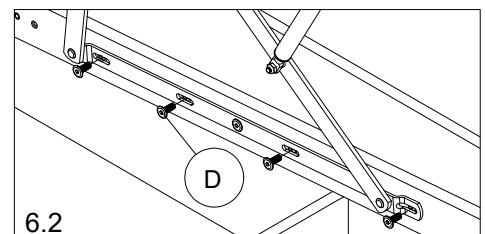
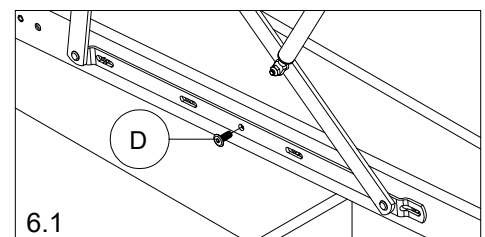
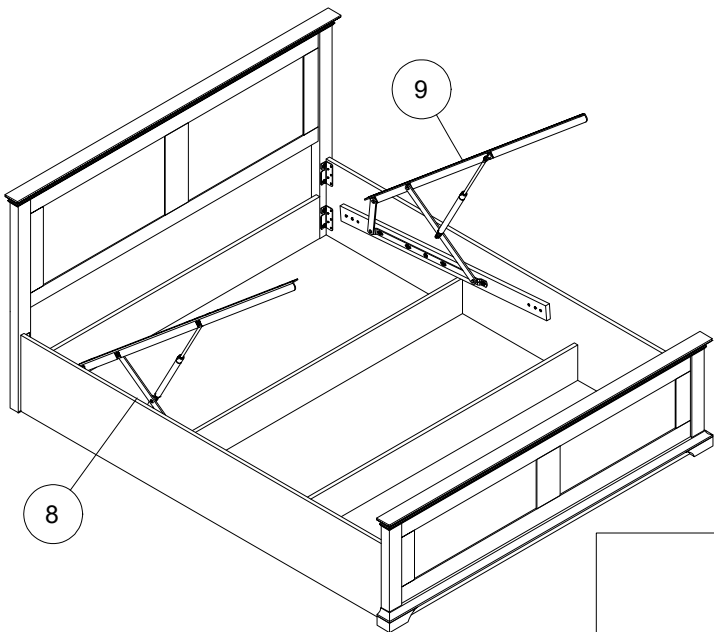

Step 5: Assemble Front Bed Base (12) to the Back Bed Base (11) and tighten fully using hardware (E,F,G,N). Attach the Base Handles (H) using hardware (I & M).

- Ensure the holes for the slats are facing up on the Back Bed Base (11) and Front Bed Base (12). Lay the two halves together and place the Base Nut (G) and M8 Flat Washer (F) on opposite sides of the central bars and tighten using M8 x 75mm Bolt (E) using M8 Allen Key (N). Repeat this step for the remaining holes.
- Connect the Base Handles (H) to the Metal Base Ends using M6 x 40mm Bolt (I) and tighten with M6 Allen Key (M).

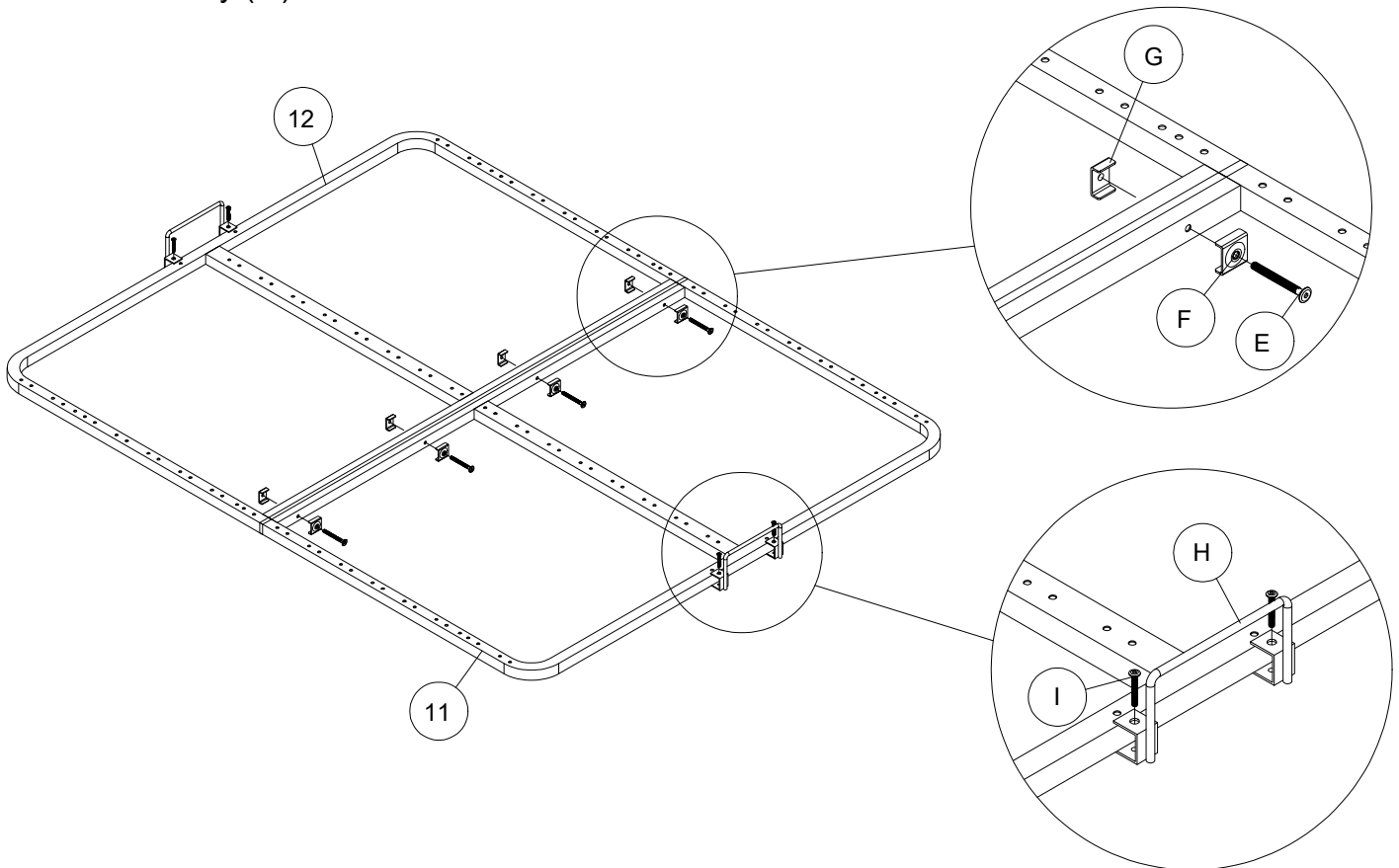

Step 6: Insert the Wooden Slats (13) into the Plastic Caps (K & L) and connect the slats to the Metal Base.

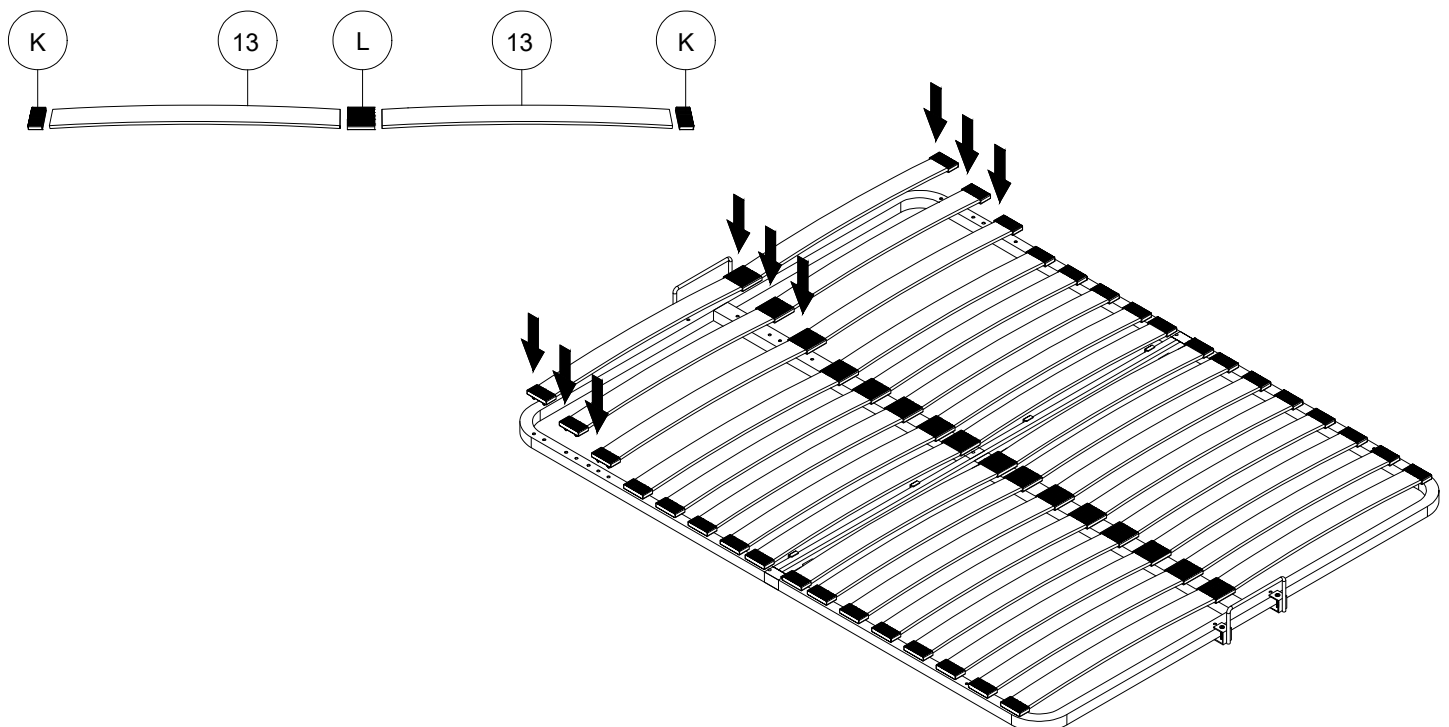

Step 7: Insert the Small Base Panel (5) and Large Base Panels (6).

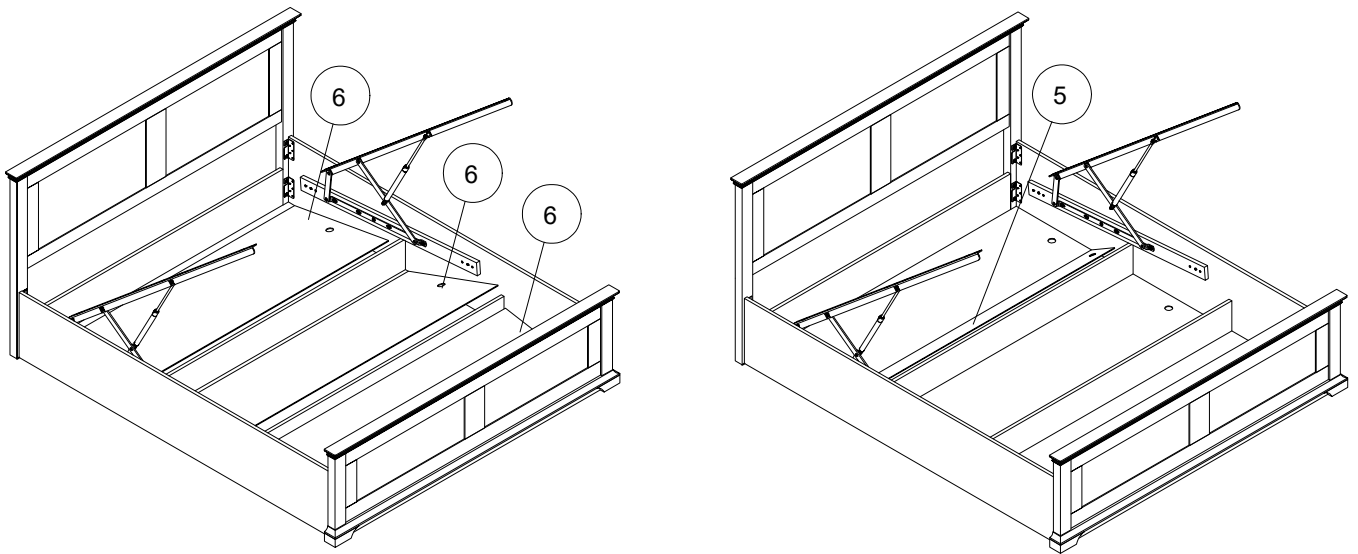

Step 8: Attach the assembled Metal Bed Base to the Hydraulic Base Supports (8 & 9) using hardware (J & N), but don't fully tighten the bolts. Start from headboard, then the middle and finally the footboard.

- Fix the assembled Metal Bed Base to the Hydraulic Base Supports (8 & 9) starting at the Headboard End using hardware (J) by placing the Spring Washer onto the M8 Bolt followed by the Flat Washer and pass the Bolt through the Metal Bed Base and secure with the Nut Bracket on the underside of the Hydraulic Base Support using M8 Allen Key (N).
- Please proceed to secure the Metal Bed Base in the middle and Footboard End on both sides.
- It's important that you don't fully tighten at this stage as we will need to adjust the Metal Bed Base in the next step.

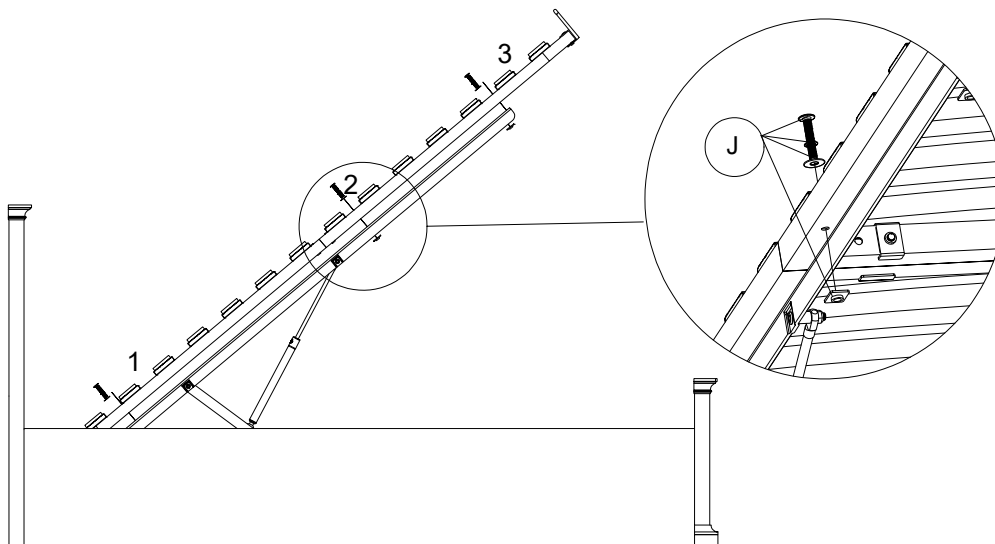

Step 9: Carefully lower the Metal Base using the Base Handle at the Footboard End. A moderate amount of force will be required, if necessary place your mattress on top of the Metal Base to assist with this.

- Adjust the position of the Metal Bed Base ensuring that the distance between the Footboard and Base Handle is approximately 15mm. Once adjusted, please fully tighten all Bolt (J) on the Metal Bed Base using M8 Allen Key (N)

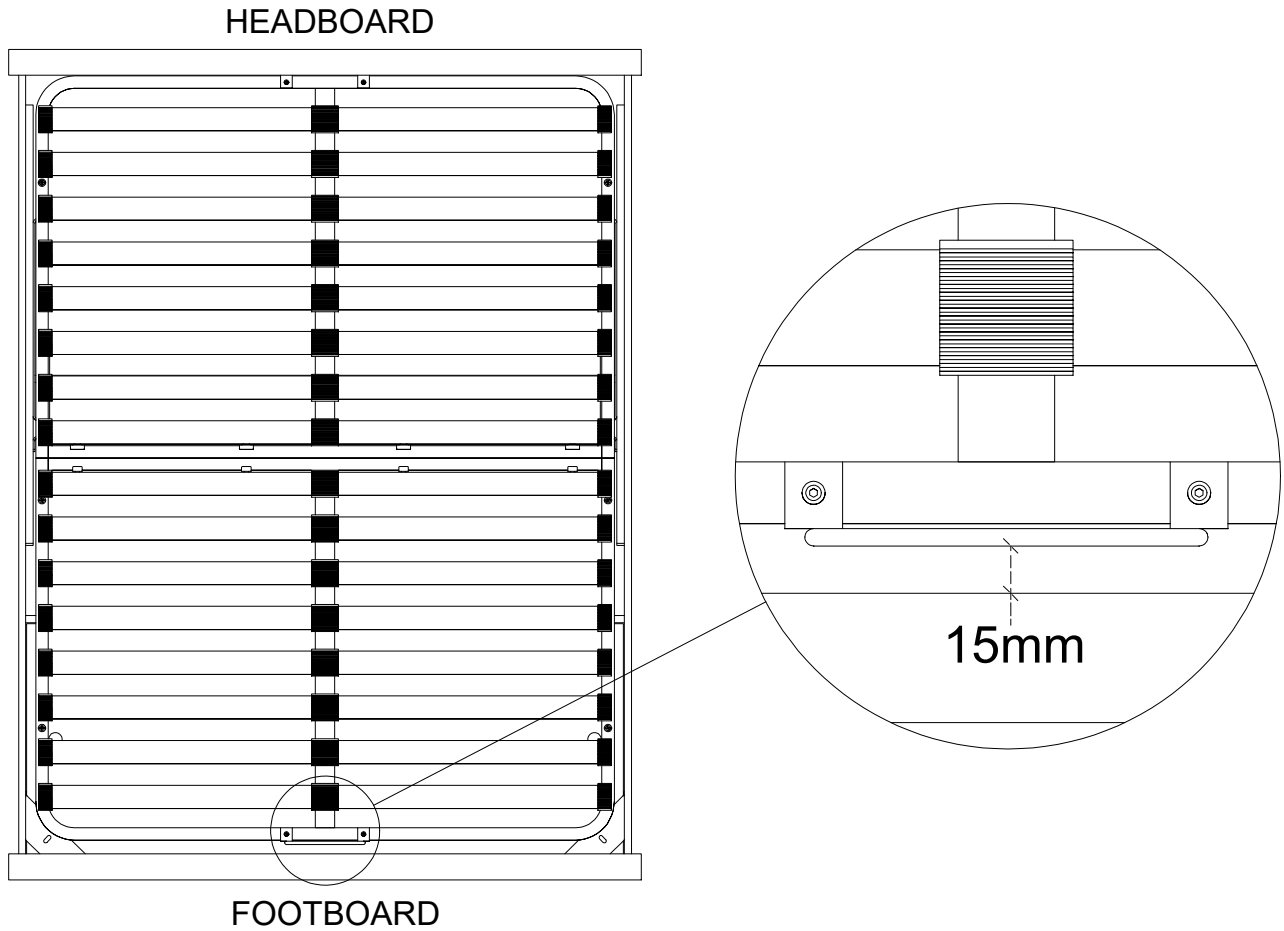

CAUTION :

PLEASE USE HYDRAULIC PUMP SAFETY LOCK WHEN ACCESSING THE STORAGE AREA.

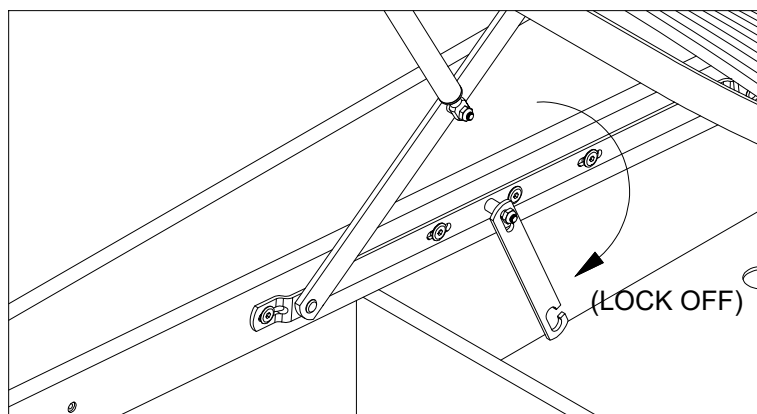
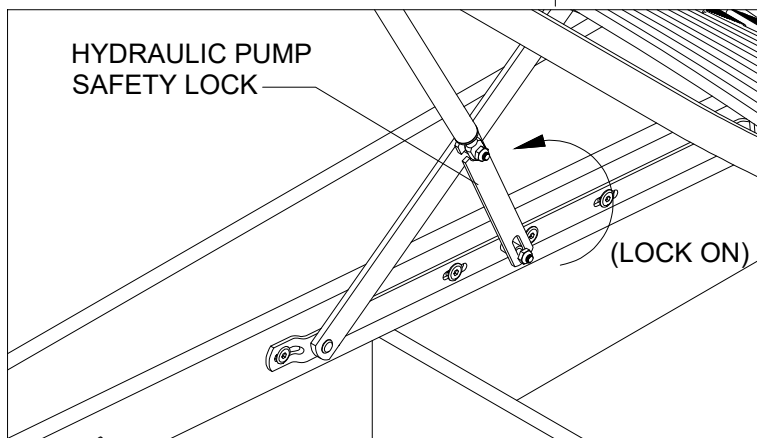
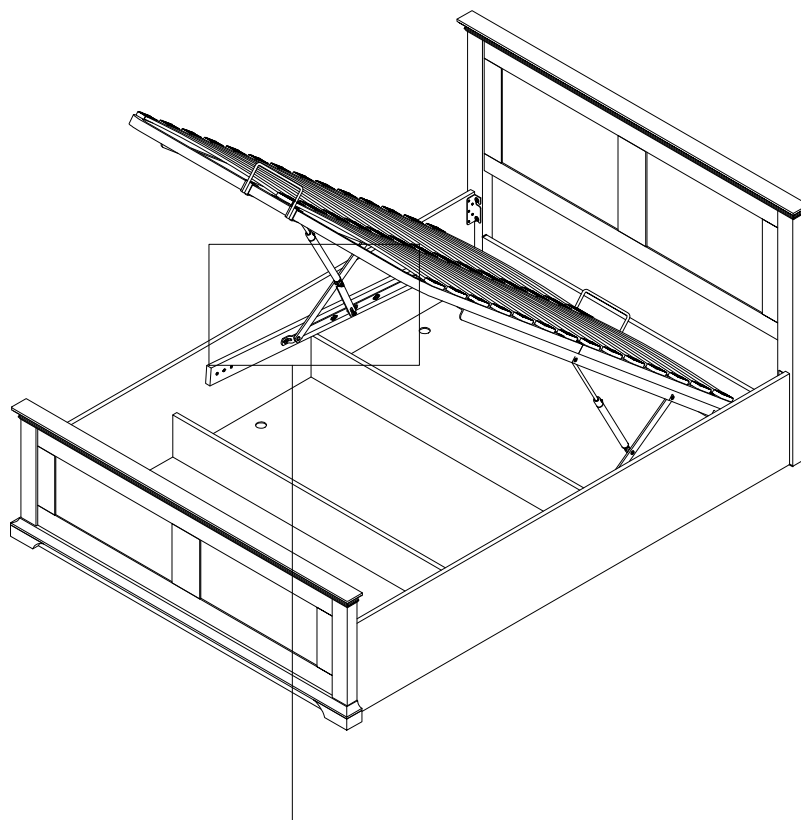

PLEASE REMEMBER TO DISENGAGE THE SAFETY LOCK WHEN CLOSING THE OTTOMAN

CAUTION :

PLEASE USE RUBBER STOPPER FOR SAFETY PURPOSE.

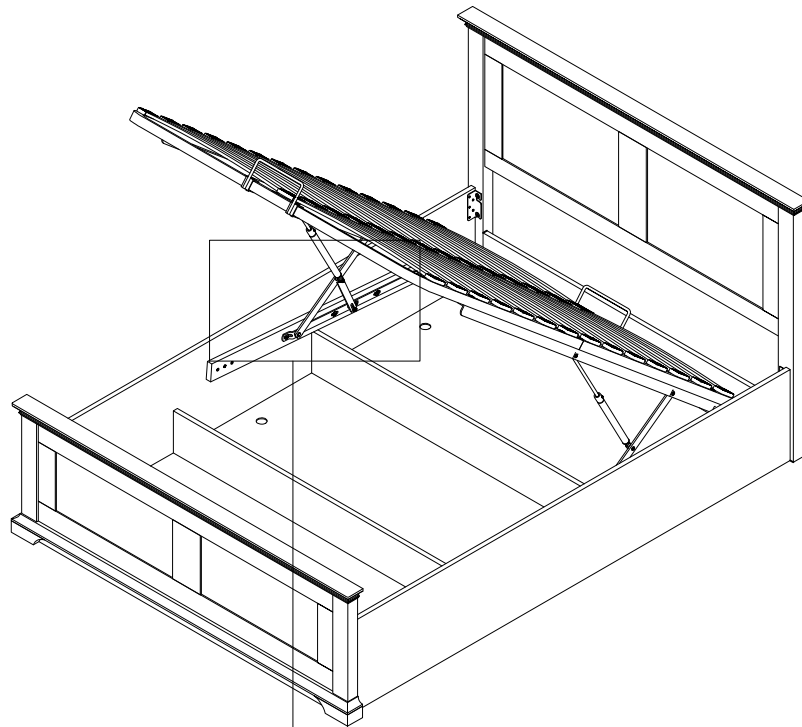



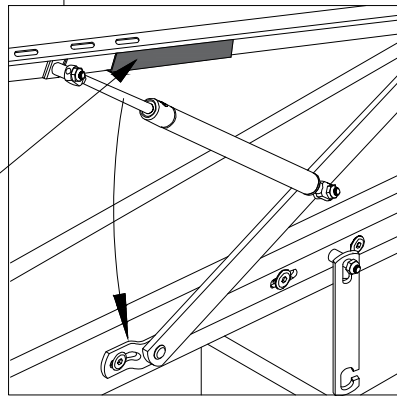

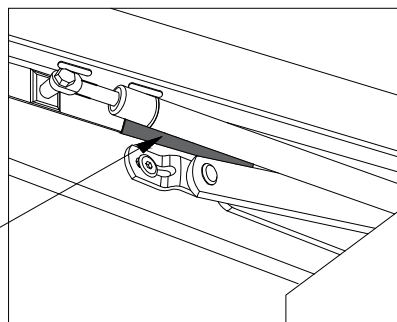

Ⓟ RUBBER STOPPER

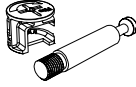

Ⓟ RUBBER STOPPER

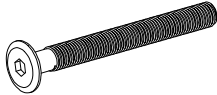

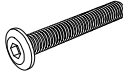
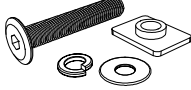
ADDITIONAL HARDWARE LIST

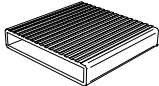
PART	DESCRIPTION	BOX	QTY
A	Cam Lock + Metal Screw Dowel 	5/5	2
B	M8 x 30mm Wood Dowels 	5/5	2
C	M8 x 16mm JCBB Bolt 	5/5	1
D	M8 x 75mm JCBB Bolt 	5/5	1
E	M8 Flat Washer 	5/5	1
F	Base Nut 	5/5	1
G	M6 x 40mm JCBC Bolt 	5/5	1
H	M8 x 45mm JCBB Bolt c/w Nut Bracket, Spring & Flat Washer 	5/5	1
I	Single End Plastic Cap 	5/5	2
J	Double End Plastic Cap 	5/5	1