

INSTALLATION INSTRUCTIONS

1. Remove rear plastic cover by loosening the 5 screws holding the cover to the frame of the vehicle.
2. Remove stock muffler starting with the springs holding the muffler inlet to the header.
3. Mount the muffler to the muffler carriage bracket (1) using the supplied hardware and clamps (2). With the muffler loosely in place, bolt the inlet and outlet pipes on each end of the muffler using supplied bolts and lock washers. (See Image 1)
4. Proceed to install the muffler assembly on the car using OEM hardware. (See Image 2)
5. Once the muffler is on the car mount the inlet pipe (3) to the muffler and then using supplied springs, attach to the header. This step will require you to adjust the position of the muffler side to side to get the inlet pipe top line up properly to the header.
6. Tighten all hardware.
7. OPTIONAL: Disassemble OEM Exhaust tip from the muffler. Attach it to the adapter on the Trinity tail pipe. (See image 3)
- 8: Reinstall rear cover using OEM hardware.

WHAT'S IN THE BOX!

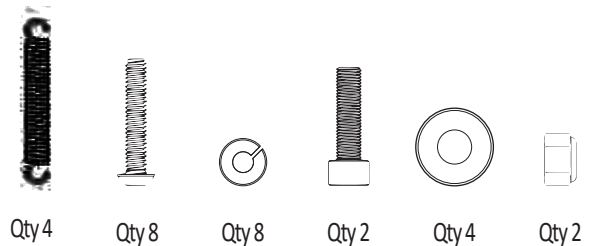
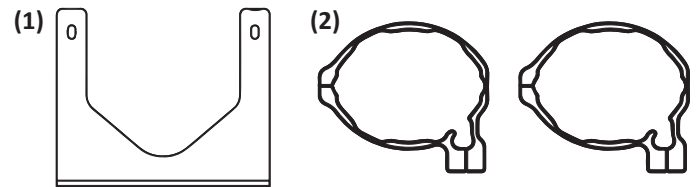
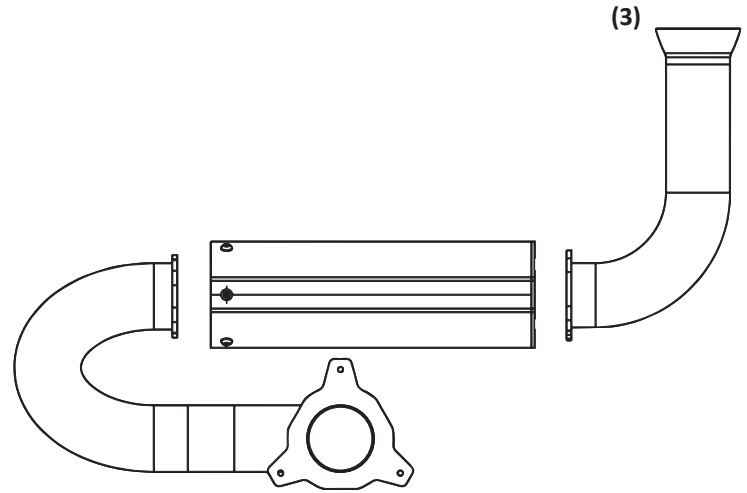



IMAGE #1A



IMAGE #1B



IMAGE #3



IMAGE #4

WARNING

* Trinity Racing exhaust systems will require adjustment to OEM fuel settings such as installation of an EFI programmer. Trinity Racing will not be held responsible for damages that occur during operation of your vehicle under improper fuel settings. Ultimately, it is the responsibility of the owner/rider to adjust fuel settings to specific riding conditions.

* Inspection of the muffler packing is recommended following every 30 hours of runtime. Failure to maintain muffler packing will result in power loss, increased sound output, and damage to the muffler body or muffler components.

* Trinity Racing exhausts systems are designed for high performance applications and are legal for closed course competition only. This product is not applicable nor intended for use on emissions controlled street, highway, or off-road vehicles.