

**Product data sheet:
Electric height adjustable desk frame 501-15**

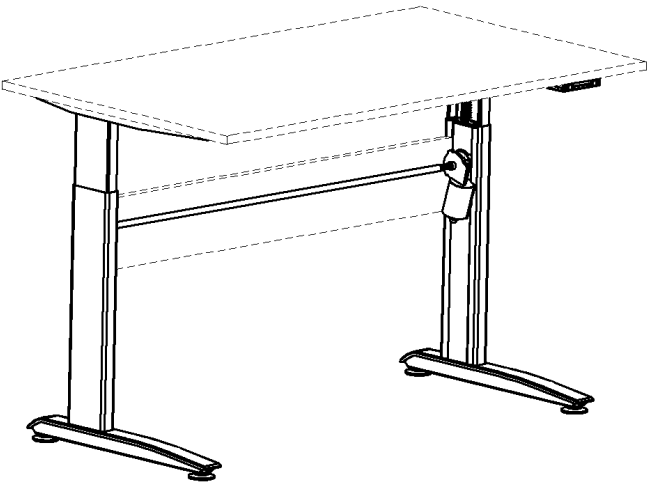
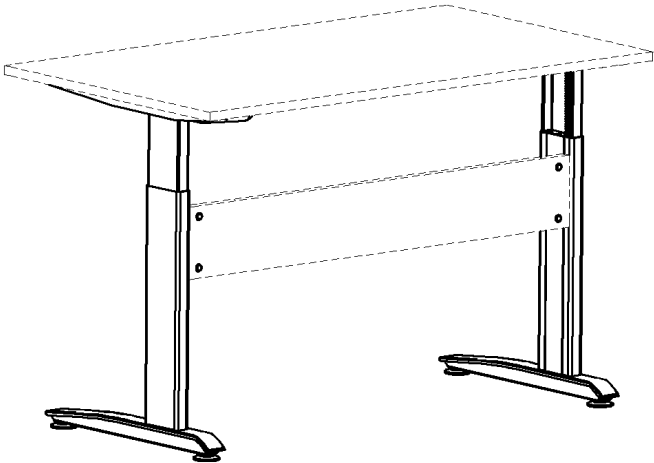
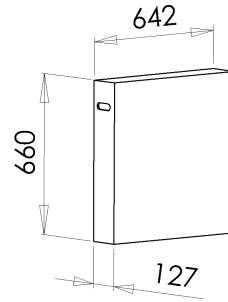
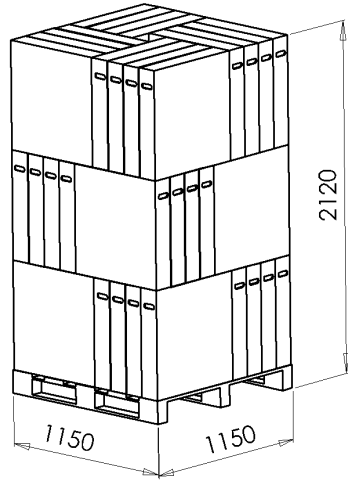

Table of contents

Technical specifications	page 3
Main measures	page 4
Specification, wooden parts	page 5
Assembly and use	page 7
Safety and tests	page 8
Specification, components	page 9

Technical specifications

Packing



Pallet containing 48 pcs. set of frames.

Weight 20 kg

Weight total 1000 kg

Content of packing

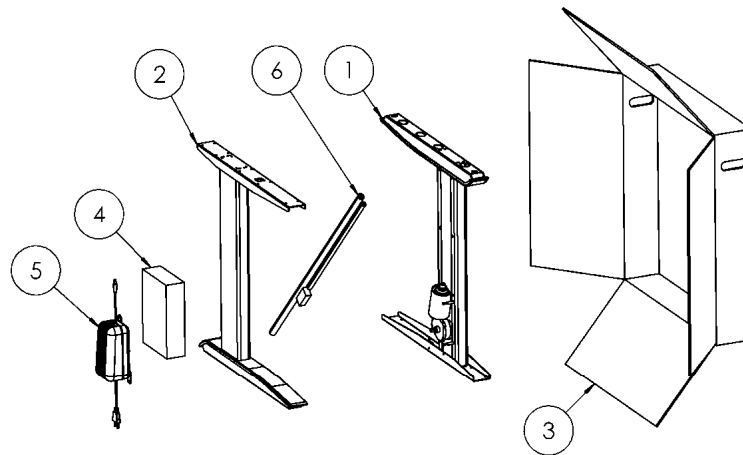

ITEM NO.	QTY.	PART NO.	DESCRIPTION
1	1	106750	Right leg assembly
2	1	106760	Left leg assembly
3	1	310150	Cardboard box
4	1	107260	501-15 overall Mounting bag
5	1	107350	Power supply assembly
6	1	109900	Adjustable tube, packed

Main measures

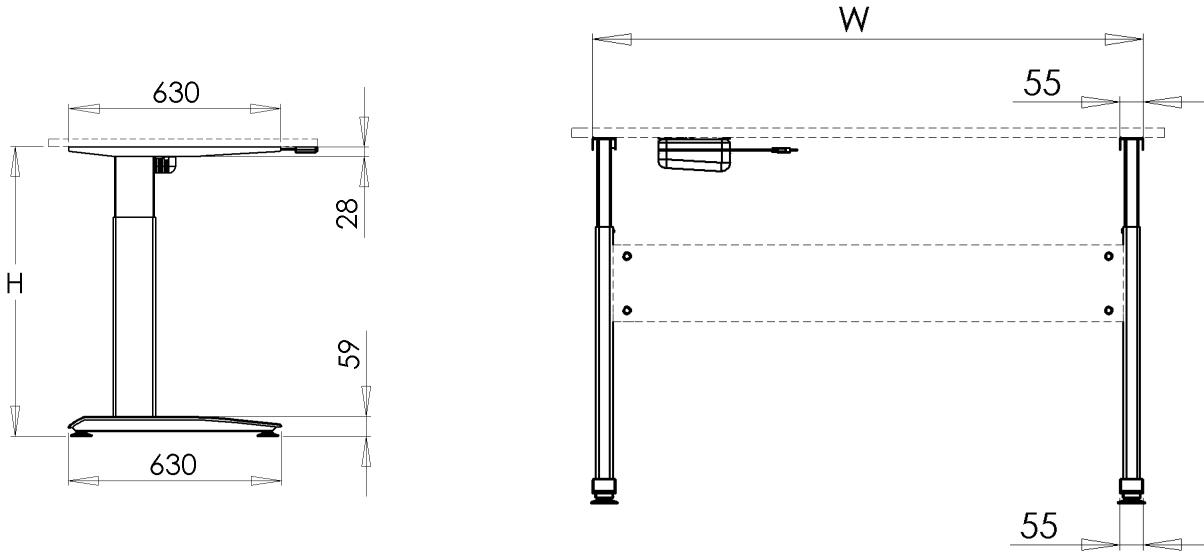

H (height), frame only	66 - 118cm
W (width)	Flexible up to 180cm
Lifting capacity, frame	70 kg
Speed	25 mm/sec

If further documentation needed, please find dwg documentation on the website.

Specification, tabletop

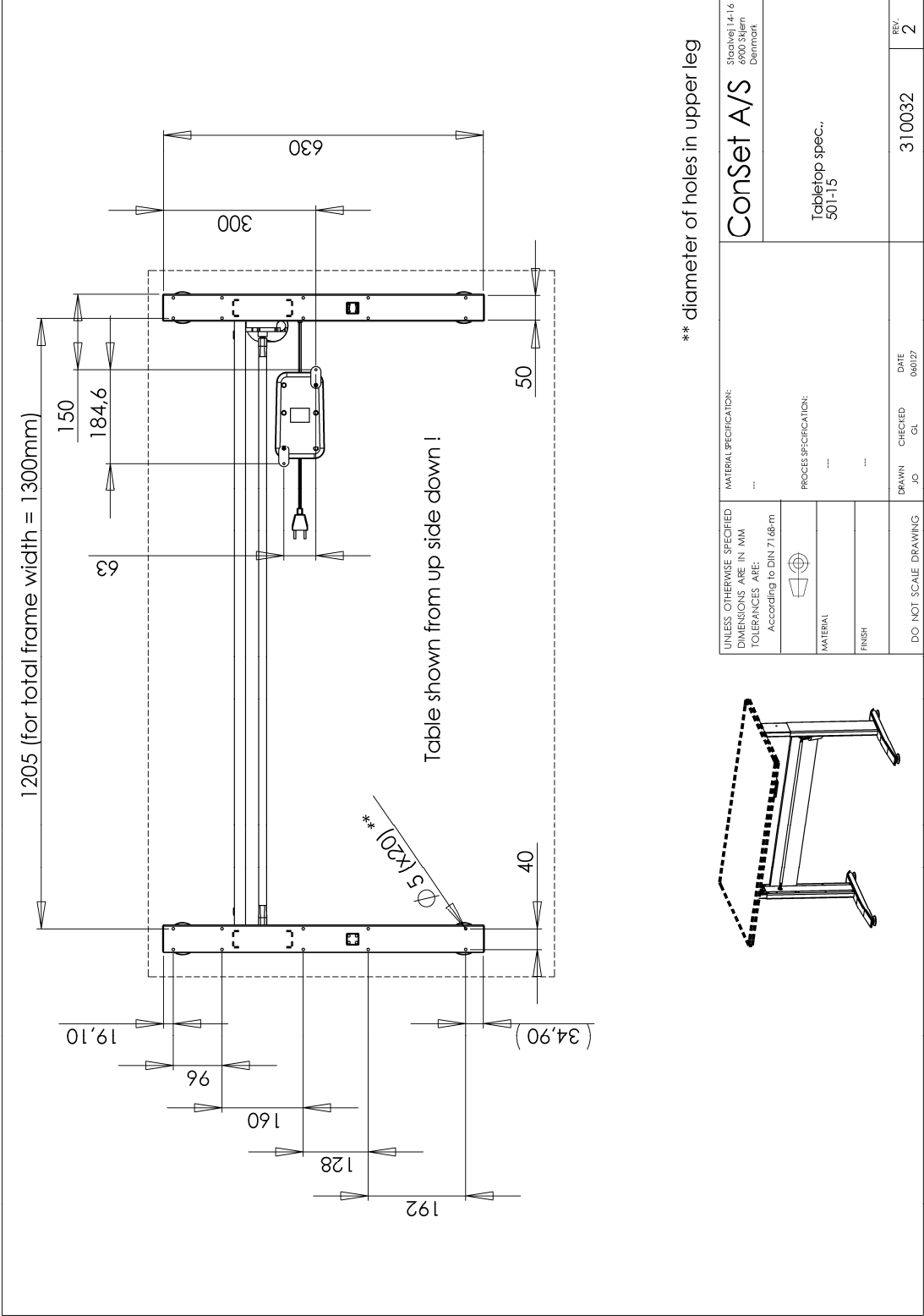

Specification, lower travers

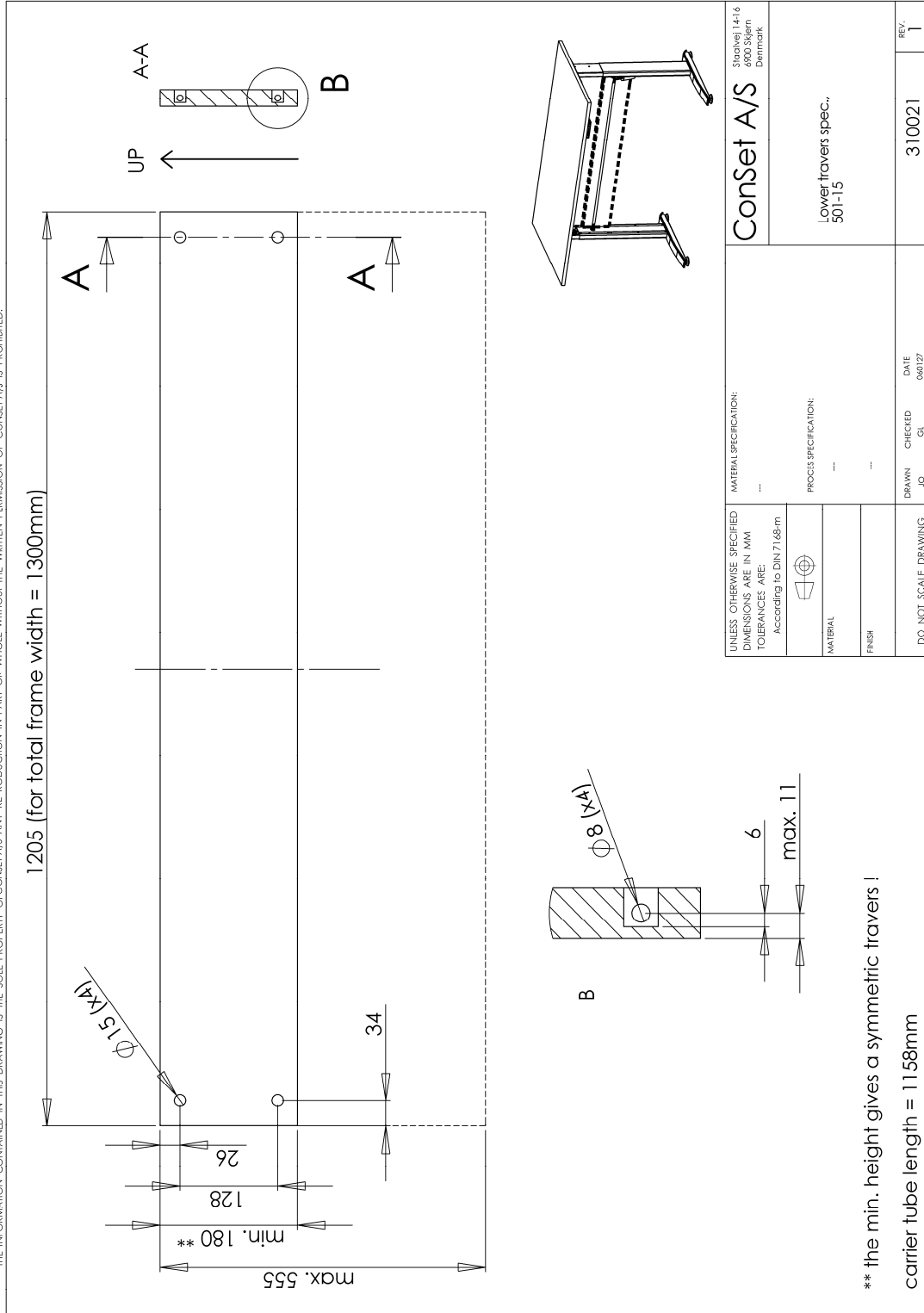

Assembly and use

Along with all products a “Direction for assembly and use” is delivered. In this you will find a detailed description of the way of assembly.

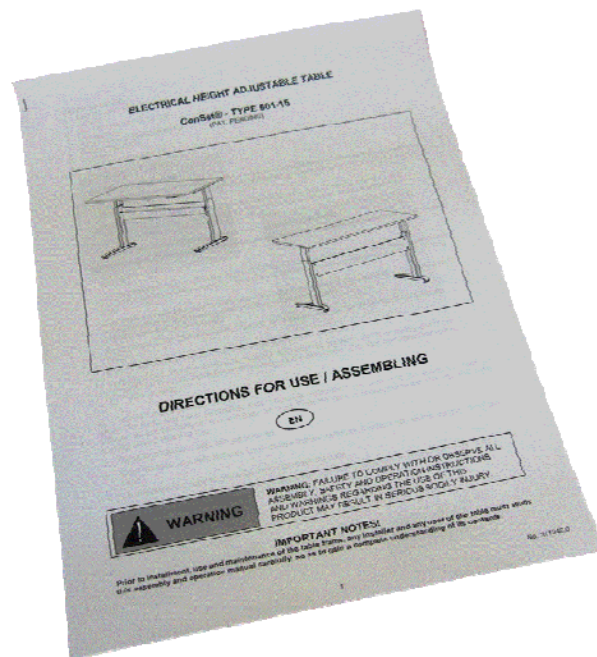

After the frame has been mounted the chosen tabletop is mounted and the operation unit will be possible to fix at the bottom side of the tabletop. This operation unit has two rocker switches.

With rocker switch A and B it is possible to move the tabletop up and down and can be stopped at all levels. For safety reasons it is necessary to push both buttons at the same time for moving the table up and down.

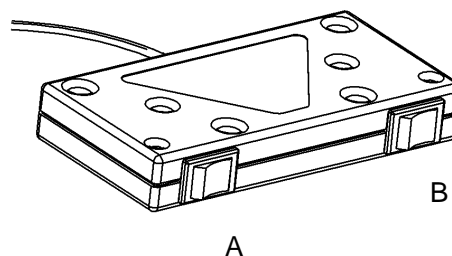

Safety and tests

All products have been tested up against the following norms:

ISO/DIS 8019

DS/ISO 7172

The norms mention above is possible to find at the website in the section "Norms and approvals".

DECLARATION OF CONFORMITY

We hereby declare, under our sole responsibility that the following products:

- ConSet sit and stand tables product type 501-15

which are covered by this statement, are in conformity with the following standards and other normative documents::

- Counsel Directive 98/37/EF
- Counsel Directive 89/336/EØF with later changes
- Counsel Directive 73/23/EØF with later changes

With reference to the Machinery Directive (98/37/EF) please be aware:

- the sit and stand table is considered a machine and
- the sit and stand table may not be used until it has been assembled and installed according to the instructions."

Component specifications

Metal sheet parts:	St 37-2
Gear parts:	St 70-2
Gear motor:	CSE 24V 300047
Power supply:	60 W AC Power Transformer Consumption: 60 Watts; Standby: 0,01 Watts
Plastic components:	PEHD, POM
Surface treatment	Visible metal parts powder coated in black/"alu" colour Non visible metal parts are surface treated (e.g. plated)