



P.O. Box 2956 · Syracuse · New York · 13220
 Phone: (315) 433-1150 Fax: (315) 433-1521
 Toll Free US & Canada: (800) 334-0837
 Email: sales@infitec.com

RC SERIES REMOTE CONTROL SYSTEM TRANSMITTER & RECEIVER

FEATURES

- System Complies With FCC Part 15
- Uses Wireless RF, Not Power Wires To Transmit Signal
- Range: Up to 1000 Feet (450 Feet Typical)
- Omnidirectional Antenna for Superior Reception
- Built-in 5 Minute 'Start Circuit Enable' Timer
- 20 Ampere 1HP @ 125 VAC Relay Output Rating
- 12VDC Vend Counter Output

SPECIFICATIONS

RECEIVER RC1433-C

1. Input

- 1.1 Operating Voltage: 120 VAC
- 1.2 Tolerance: ±15% of Nominal
- 1.3 Frequency: 50 - 60 Hertz
- 1.4 RF Operating Frequency: 433MHz
- 1.5 Range: Up to 1000 Feet (Depending on conditions)
450 Feet Typical

2. Output

- 2.1 Type: Electromechanical Relay
- 2.2 Form: SPST, N.O.
- 2.3 Rating: 20 Amperes, 1HP @ 125 VAC
- 2.4 Life: Electrical - Full Load - 100,000 Operations
Mechanical - 10,000,000 Operations

3. Mechanical

- 3.1 Mounting: End Mounting Ears, #8 Screw Clearance
(2 Places)
- 3.2 Termination: Wire Leads - 25" Minimum With 1/4" Quick
Connect Terminals (Supplied)
(2) Black, (2) Blue, (1) White
(2) 1/4" Male Quick Connect (Integral to Relay)
- 3.3 Style: Surface Mount/Encapsulated
- 3.4 Antenna: ANT1433-A - External Omnidirectional
(Mount to Top of Enclosure)

NOTE: ALL COMPONENTS SHOULD BE MOUNTED AS FAR AWAY FROM COMPRESSOR AS POSSIBLE

4. Protection

- 4.1 Transient: Movistor Protected to 10 Joules
- 4.2 Dielectric Breakdown: 1500 Volts RMS Minimum

5. Environmental

- 5.1 Operating Temperature: -20°C to +75°C
- 5.2 Storage Temperature: -30°C to +85°C
- 5.3 Humidity: 95% Relative, Non-Condensing

MODE OF OPERATION

REMOTE CONTROL RECEIVER/TIMING SYSTEM

Upon application of power with no received signal, the receiver/control is de-energized and the control is reset.

Upon receiving a properly coded signal, the latch-in timer begins and the load timer start circuit is enabled, and will remain enabled until the latch-in timer completes its 5 minute delay.

Upon closure of the of the start button (momentary or maintained) while the start circuit is enabled, the vend counter (if connected) increments one time, the load timer begins and the load output energizes.

Upon completion of the time delay, the load output de-energizes.



SPECIFICATIONS

TRANSMITTER RC1433-B

1. Input

- 1.1 Operating Voltage: 12 VDC N-Cell Battery (Included)

2. Output

- 2.1 Type: Wireless RF Signal
- 2.2 Frequency: 433MHz
- 2.3 Range: Up to 1000 Feet (Depending on conditions)
450 Feet Typical

3. Mechanical

- 3.1 Mounting: Supplied With 22" Anti-Theft Cable Attached
(See Diagram)

MODE OF OPERATION

REMOTE CONTROL TRANSMITTER

When the pushbutton is pressed for a minimum of **5 seconds**, the unit transmits the enable signal and illuminates the LED on the unit.

RC1433-B FCC ID: Q6R-HHTX-ASW-433

RC1433-C Complies with FCC CFR47 15.109 and 15.107

ORDERING INFORMATION

RC1433-B - Transmitter

RC1433-C - Receiver with Omnidirectional Antenna

DIMENSIONS

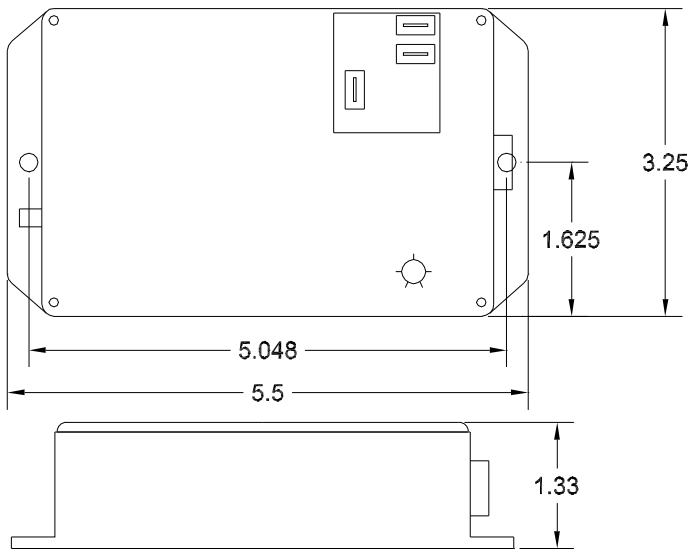

RECEIVER / TIMING SYSTEM

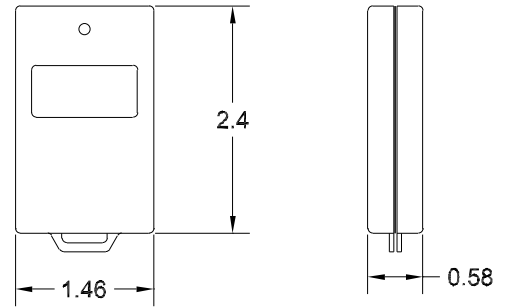

TRANSMITTER

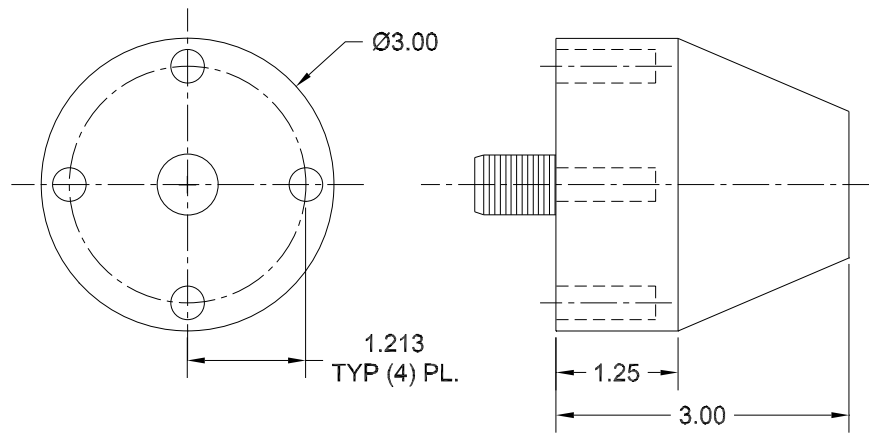

OMNIDIRECTIONAL ANTENNA

CONNECTION DIAGRAMS

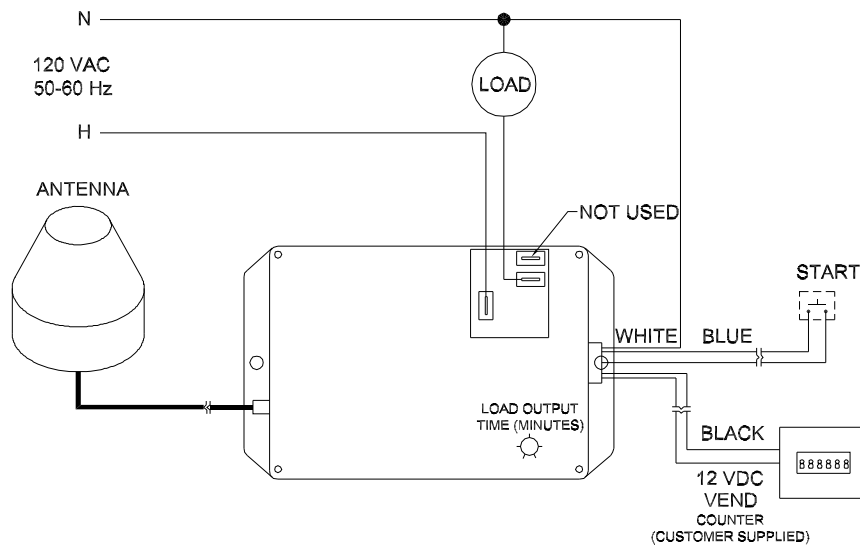

RECEIVER / TIMING SYSTEM

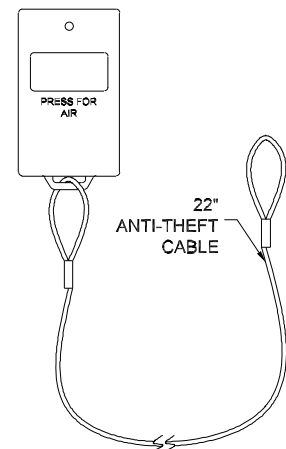

TRANSMITTER

OMNIDIRECTIONAL ANTENNA MOUNTING

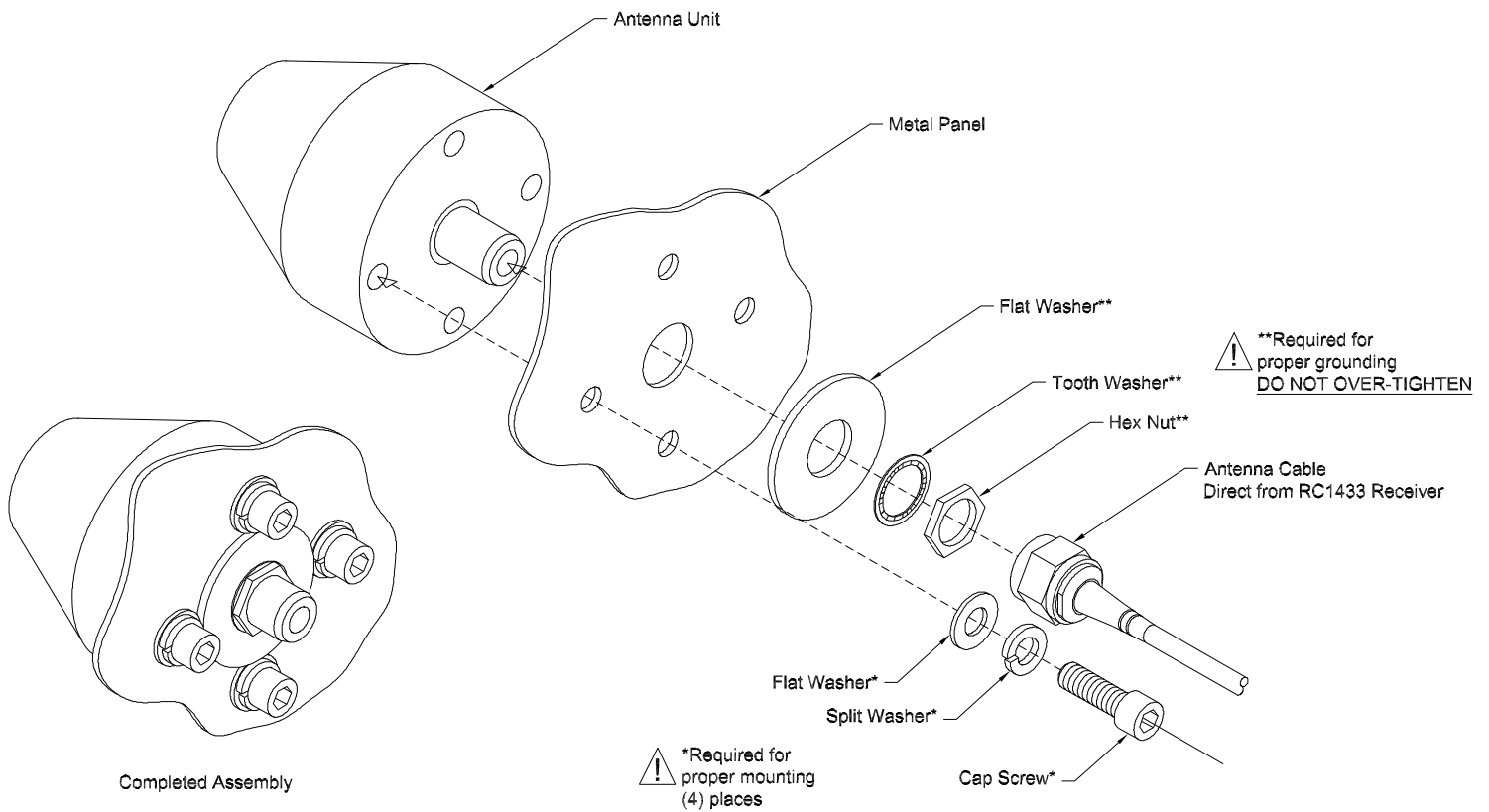

PANEL MOUNT TEMPLATE

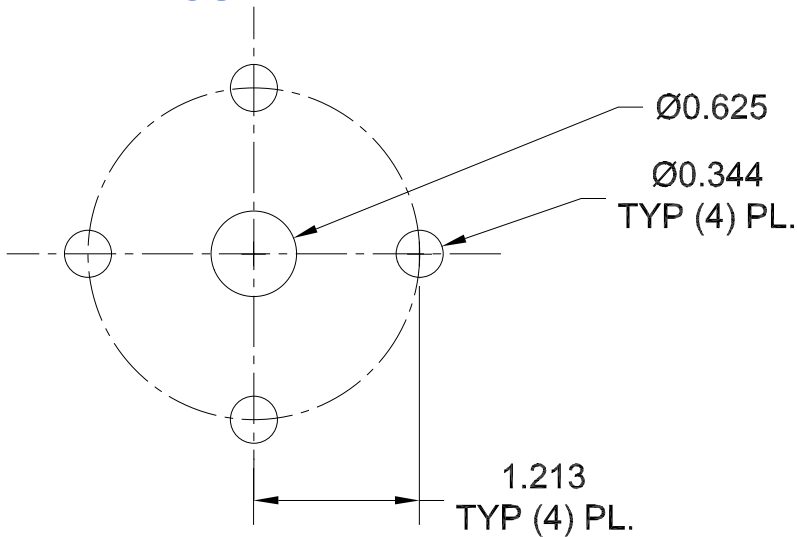

MH - (4) Mounting Holes = 11/32"
CH - (1) Center Hole = 5/8"

PANEL MOUNT EXTERNAL DETAIL

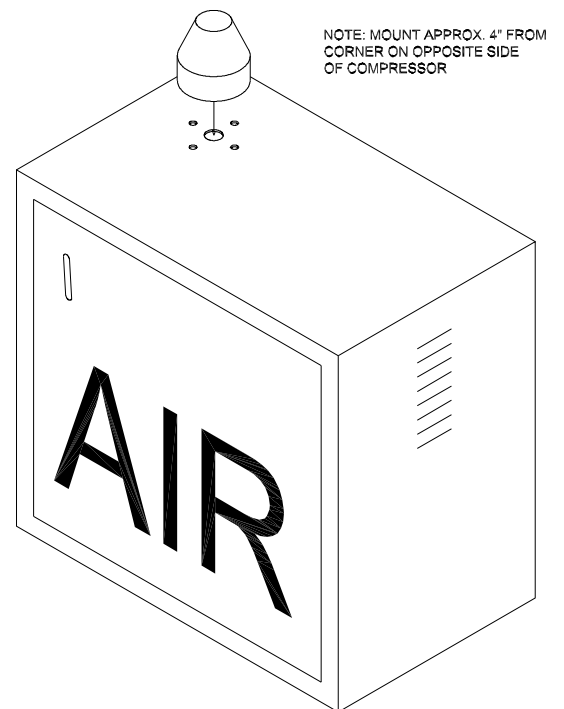

MOUNTING INSTRUCTIONS

1. Mount antenna to the top surface on the exterior of the machine.
2. Secure antenna with (4) cap screws with washers inside cabinet.
3. Install larger flat washer around antenna connection and secure with tooth washer and hex nut.

Snug fit. DO NOT OVERTIGHTEN.

4. Antenna base should be flush with outside of cabinet.