

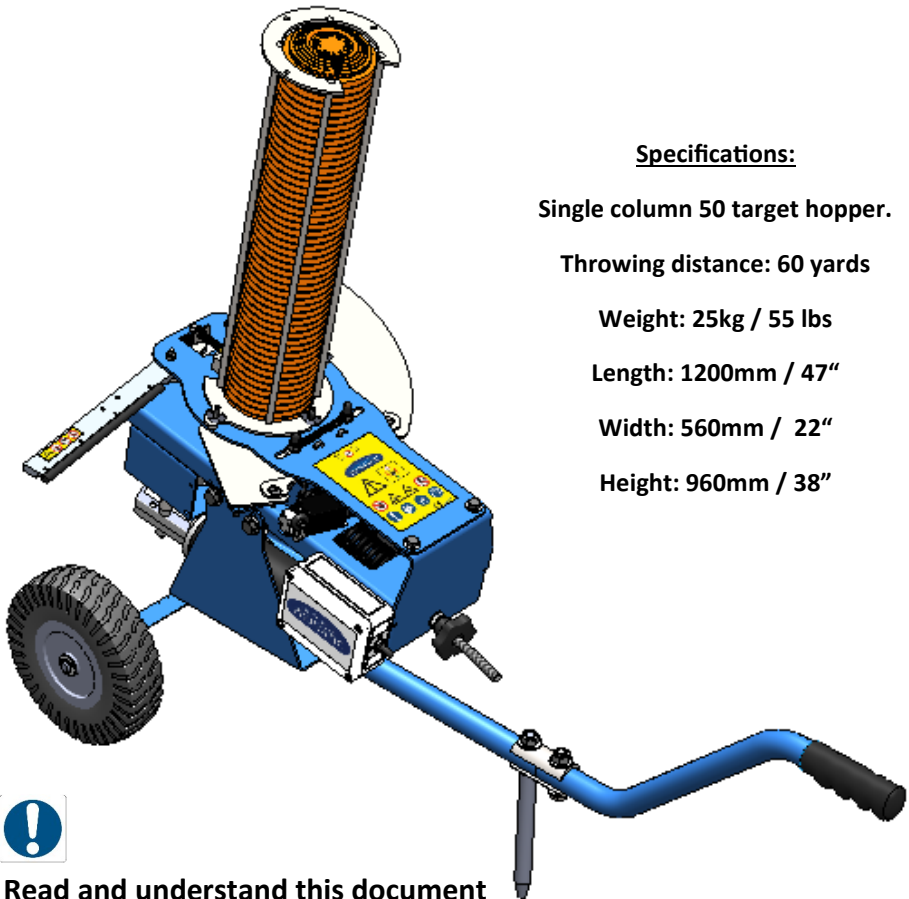

Operating Instructions

Pigeon - Clay target launcher



Specifications:

Single column 50 target hopper.

Throwing distance: 60 yards

Weight: 25kg / 55 lbs

Length: 1200mm / 47"

Width: 560mm / 22"

Height: 960mm / 38"



Read and understand this document
before attempting to operate the
machine.

WARNING

Clay target launchers can be dangerous and must be treated with great care at all times to avoid accidents.

Never place any bodily part into the path of any mechanical piece whilst the machine is in motion or likely to be so.

You must treat a clay target launcher with the same caution that you would treat a loaded gun.

Assume at all times that a clay target launcher is armed and loaded and treat it accordingly

ALWAYS disarm the machine before any loading, adjustment or maintenance.
ALWAYS load clays from rear and **ONLY** if the machine is disarmed and safe.
NEVER approach the machine from the front or sides. **ALWAYS** from the rear.
NEVER allow children or untrained persons to approach or touch the machine.
NEVER move an armed/loaded machine. **ALWAYS** disarm and disconnect battery.
REMOVE the main throwing spring before Transport in a vehicle.
BE AWARE of the fall zone of both broken and unbroken clays and that a change in wind direction will affect this.

Conventions used within this manual:

Trap: Your Clay target launcher—commonly known as a clay trap and may be referred to in this manual as “The trap” or “The machine”



Warning: This section contains instructions which, if ignored or carried out incorrectly, may result in risk of personal injury.



Caution: This section contains instructions which, if ignored or carried out incorrectly, may result in malfunction or damage to the equipment or consumables.



Note: This section contains additional information which the user may find useful, but is not essential to the operation of the product.

Preface:

Every effort has been made to ensure that the information contained within this manual is complete, accurate and up-to-date. Promatic International assumes no responsibility for errors beyond its control.

Warnings & Cautions:



12v DC Power Source:

This product is designed to be powered from a 12v DC leisure battery.

We recommend 22Ah (approx.) leisure batteries. Promatic part no. E30V/SLC22

IT MUST NOT BE DIRECTLY CONNECTED TO MAINS AC POWER



EYE PROTECTION MUST BE WORN WHEN WORKING ON OR AROUND A CLAY TARGET LAUNCHER AS SMALL SHARP PIECES OF CLAY MAY BE EJECTED DURING NORMAL USE.



Ensure the machine is stable on firm level ground before use.



Never approach the machine from the front or sides, Do not assume the trap is safe even without electrical power as it may still be armed.



Battery type: The ideal battery for this trap would be a sealed lead/acid (SLA) or Gel type battery of around 20 - 22 Ah Capacity.

Assembly of your new trap.

Your new trap is supplied only needing the trolley to be assembled, the trap fitted onto it and then the cocking spring to be fitted. Assembly is straightforward with all the necessary parts in the box. These are loose in the box, care should be taken not to discard small packages with the packing materials.

Follow the instructions and refer to the diagram below for guidance as to how complete the assembly. We suggest you carry out assembly in the following order.

The tools you will need are:

13mm (1/2"), 14mm (9/16") & 19mm (3/4") Spanners (Wrenches), medium size adjustable spanner & medium size pliers.

CAUTION, Do Not Install Spring On Machine Until All Other Assembly Is Complete!

1. Assemble Trolley Axle and Handle Assembly. (12mm bolt & nut)
2. Attach Axle to Machine Base (8mm bolts & nuts)
3. Attach Handle Assembly to Machine Base (8mm bolts & nuts)
4. Compare Illustration in Manual to Your Assembly and Double Check that all Fasteners are Tight.

Once you are satisfied with the assembly, continue to the next section.

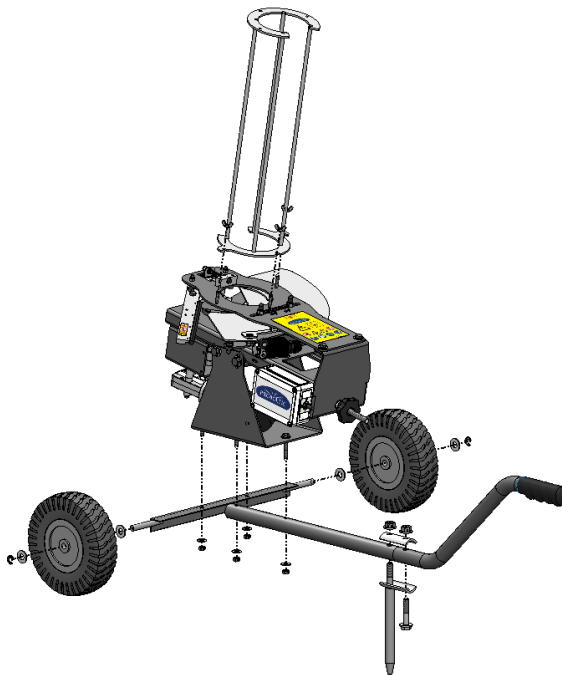

Fitting the Cocking spring.

Before starting , it is necessary to have the throwing arm pointing forwards. To do this ensure you are behind the machine, the toggle switch is in the **○** (OFF) position and it is otherwise safe to proceed. Connect the battery (see below) and jog the motor around by momentarily lifting the toggle switch until the arm is straight ahead.

Now disconnect the battery.

Hook the cocking spring's hooked end around the spring bush then pass the threaded shaft through the hole in the rear of the mainframe, checking that the spring hook remains on the bush.

Pass the nylon 'top hat' collar over the spring from the outside and locate it through the rear plate. Wind the hand wheel along the thread and loosely tighten. It is recommended to begin use of the trap with a low spring tension to bed in the spring.

At this stage, do not re-connect the power supply. First ensure you know how to disarm the machine and make it safe.

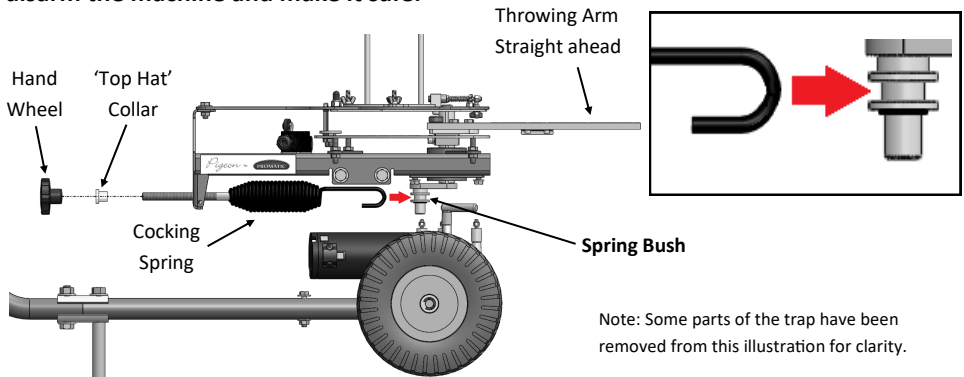

Note: Some parts of the trap have been removed from this illustration for clarity.

Positioning the machine

1. Clay Target Launchers must be situated on firm level ground in a position that will allow unrestricted access to rear of machine.
2. There must be no obstructions to the path of the throwing arm.
3. Ensure that the power supply can be easily disconnected and cables cannot become entangled in any part of the mechanism.
4. Give thought to the path of the target ensuring an uninterrupted flight and that there is a safe fall zone for targets and target debris.

Disarming the machine

Use this procedure to make the machine safe before maintenance or after use.

1. Push the toggle switch upwards to the **⏏** (DISARM) position and hold only long enough for the trap to fire then release before the trap can rearm.
2. Disconnect the battery.

Connecting the battery:

Ensure you are behind the machine, the toggle switch is in the  (OFF) position and it is otherwise safe to proceed. Connect the red cable connector to the positive (+) terminal and the black cable connector to the negative (-) Terminal. Ensure the battery charger has been disconnected.

Loading and Firing the Machine

1. Perform the disarming procedure regardless of the state of the machine (see above).

2. After disarming, the throwing arm should be at the 9 o'clock position when viewed from behind the machine. This means the drive pin (1) will be behind the drive arm (2). The drive arm (2) will be pointing approximately towards the front.
3. Push the throwing arm counter clockwise until the irises close or the drive pin touches the drive arm. (You will be pushing against the spring so some effort will be needed).

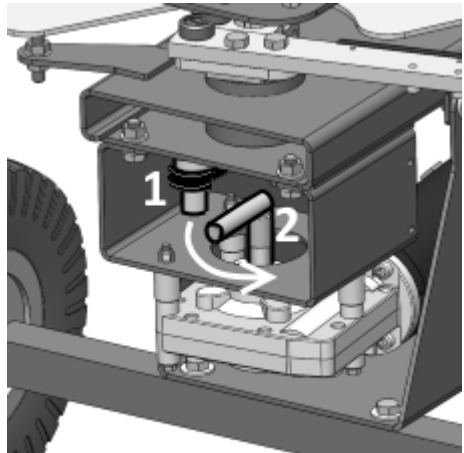

4. **Important!** Place a clay onto the casting plate beneath the hopper and close to the back rail. This is to avoid 'Dry Firing' which can lead to broken clays in the hopper due to excessive recoil.

THE IRISES LIE BENEATH THE TOP PLATE. BOTH IRISES MUST BE CLOSED BEFORE LOADING THE HOPPER WITH CLAYS.

5. Load the hopper with clays.
6. Push the toggle switch at the rear of the machine down to the  (ON) position. The machine will move automatically and arm itself ready to launch a clay.

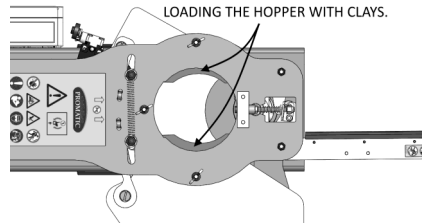

7. Depress the foot switch to throw a clay.
8. The machine will automatically rearm itself after each clay thrown, until disarmed and turned off. Simply turning off the machine does not make it safe—always disarm after use, before reloading or moving it.

Machine Adjustments.

This clay trap is designed to be simple in operation and should work 'out of the box'. There are however a few adjustments available to the user to enhance the shooting experience.

Elevation:

There are 2 bolts on each side of the machine. Loosen all 4 bolts and move the trap to the desired elevation. Retighten the bolts firmly. When the bolts are loose the trap can move unexpectedly. Support the weight of the machine from the top of the clay hopper when adjusting the elevation angle.

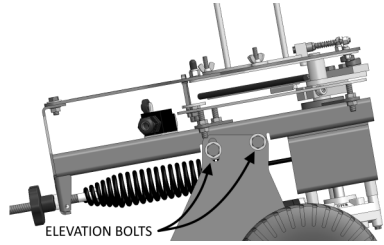

Plunger Mechanism

Clay diameters vary so this adjustment can be made to allow for this. This is set from the factory so should not need adjustment except in exceptional circumstances.

During the arming process, the plunger presses onto the rim of the second clay in the hopper to hold it as the bottom clay is released from the iris plates. With the trap at rest and the clays pushed towards the two rear hopper rods, the plunger gap should be around 1 to 2mm (1/16") and can be adjusted if required using two 10mm spanners/wrenches. Holding the nut (located against the back of the brass plunger) adjust the rear locking nut clockwise to increase the gap or anti-clockwise to decrease it.

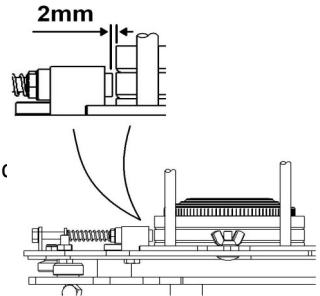
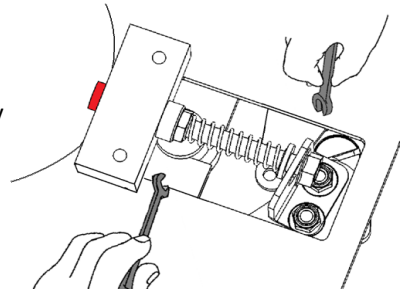

Adjustment: Spring Tension

Decrease tension—Turn the hand wheel counter-clockwise to loosen spring to desired position. This will reduce the range of the trap.

Increase tension—Turn the hand wheel clockwise to increase the spring tension. This will increase the range of the trap.

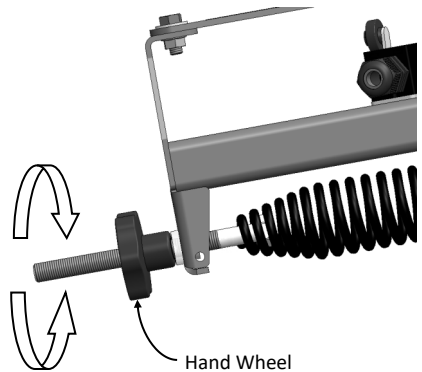

Adjustment: Throwing arm timing

The arm timing and the roller switch are fixed and no adjustment is necessary.

Troubleshooting:



It is not recommended to fire the machine without a clay loaded. The excessive recoil can break the clays in the hopper, particularly at high spring tension.

Machine will not throw clays. The following are possible scenarios and their fixes.

The clay flicks up in the air:

The arm is probably bent down or the casting plate bent up, squeezing the clay between them. The arm or plate should be replaced or straightened.

The clay goes no distance: (even though the main spring is wound up tight.)

The arm is probably bent upwards causing clay to go under it at its tip. This will also cause clays to break. The solution is to straighten the arm.

The clays are inconsistent in direction:

The clay is being jammed under the arm towards the end. This is usually caused either by the arm being bent down, the tip bent up or more likely clays varying in thickness. The solution if the arm is bent is to straighten it. If it is the clay thickness that is the problem then adjust the casting plate height to accommodate the thickest clay you can find.

The machine breaks clays:

Check that the clays in the magazine are intact, not chipped or cracked. If in doubt, remove suspect clays and use clays known to be intact.

Place two clays at the bottom of the magazine. Check that the tip of the brass plunger (the rubber tip) is about 1-2mm away from the top clay. If the gap is any larger, you may experience problems with the machine feeding two or more clays at a time. If there is no gap and the clay cannot fall past the plunger, then this will cause problems as well.

To adjust the plunger, two spanners are required. Put one spanner onto the nut which is locked against the brass plunger. Put the other spanner on the nylock nut which sits at the other end of the plunger, behind the aluminium bracket. By turning the nylock nut whilst holding the other nut, the plunger can be made to move in and out of the plunger hole. This is how the distance is set between the tip of the plunger and the side of the clay.

Set the correct gap as necessary. Once this is set, fill the magazine with clays. The machine can now be cycled to check that a single clay drops onto the throwing plate intact.

Check throwing cycle next:

Check the throwing arm for straightness, and the friction strip for damage. If the arm is bent and cannot be straightened then it should be replaced. A new friction strip can be fitted to an old arm if necessary.

Check the casting plate (especially the front edge) for damage. Check for flatness, and that there are no other obstructions to the clays path. Repair or replace if necessary.

Check the height of the throwing arm over the casting plate across its entire sweep to ensure that the clay fits under the friction strip with about 1 mm clearance. Less than this or more than 3mm clearance could cause the arm to break the clay.

Slacken the main spring to its minimum. Operate the trap a few times in this mode, This minimises the stress on clay during firing. If the clays still break then it is likely that the clays are sub standard and a new batch should be obtained.

Electrical Troubleshooting :

Machine does not cock (i.e. come to the loaded position.)

Check the battery is charged and all wiring connections are tight. Ensure the toggle switch is in the down arm/load position. Check for broken wires and damaged connections. Check the Throwing arm is clear of the roller switch. If not, then press the toggle switch up to the dis-arm position until the arm is clear. If the motor does not turn then check the fuses in the electrical box.

Machine runs in 'DISARM' position, but not in 'ON' position.

If the arm is clear of the roller switch then the toggle switch is faulty. Move wheel on the end of the roller switch from side to side and check to see if it returns to the central position, also check the two wires inside the switch are both connected.

Machine cocks, but will not fire on command cable button or foot switch.

Either the connections, cable or command push button are faulty. Disconnect the command cable and using a short wire or paperclip etc, short across the 2 lower pin holes of the socket (do not touch the upper hole). If the trap does not fire then it may be necessary to change the wiring loom or repair it. If the trap does fire then reconnect the command cable, remove the cover on the push button box or foot switch and short across the two connectors. If the trap fires then the push button is faulty. If the trap does not fire then there is a broken wire or bad connection in the command cable.

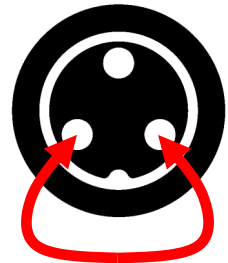

The trap fires by itself.

Disconnect the foot switch cable and switch the trap back on. If the trap cocks normally and does not fire then the foot switch cable is faulty. If the machine still fires by itself then the Roller switch is faulty and must be replaced.

Notes:



For Service and Supplies contact your local Trap Supplier.

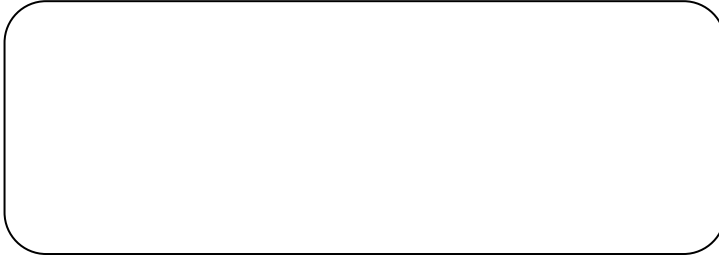

Follow Promatic on social media:



www.facebook.com/PromaticTraps



www.twitter.com/promaticltd

Subscribe to the Promatic newsletter. Browse to:

www.promatic.co.uk/keep-in-touch

Be sure to ask your supplier for Promatic Clays.

www.promatic.co.uk/all-products/clays



Promatic International Ltd.

**Hooton Road
Hooton
South Wirral
CH66 7PA
United Kingdom**

Tel: +44 (0) 151 327 2220 (General)

Fax: +44 (0) 151 3277075

E-mail info@promatic.co.uk

Website: www.promatic.co.uk

**Promatic Inc.
801, Mid America Drive,
Plattsburg.
MO 64477
USA**

Toll Free: 888.767.2529

Fax: 816.539.0257

E-mail: sales@promatic.biz

Website: www.promatic.biz