



Falcon - Clay target launcher Rear Pusher Timing Method

WARNING

Clay target launchers can be dangerous and must be treated with great care at all times to avoid accidents.

Never place any bodily part into the path of any mechanical piece whilst the machine is in motion or likely to be so.

You must treat a clay target launcher with the same caution that you would treat a loaded gun.

Assume at all times that a clay target launcher is armed and loaded and treat it accordingly

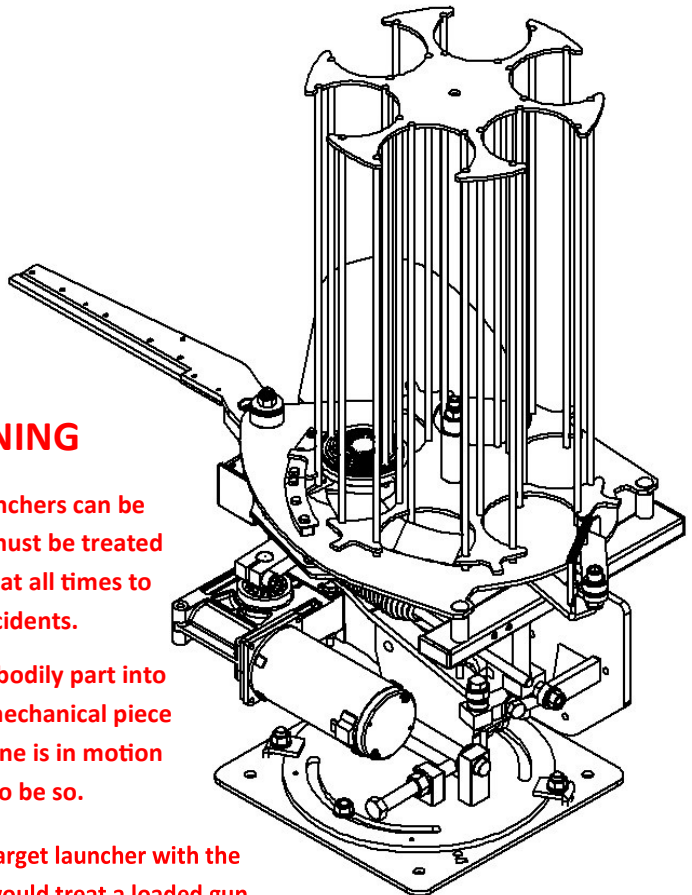

This document must be read in full before attempting to operate the machine

Preface:

Every effort has been made to ensure that the information contained within this manual is complete, accurate and up-to-date. Promatic International assumes no responsibility for errors beyond its control.

Conventions used within this manual:

Trap: Your Falcon - Clay target launcher - commonly known as a clay trap and may be referred to in this manual as "The trap" or "The machine".

These instructions MUST be read in conjunction with the users manual.



Never approach the machine from the front or sides, Do not assume the trap is safe, even without electrical power it may still be armed and can fire without power being applied.

GENERAL WARNINGS - BEFORE OPERATING ANY TRAP

ALWAYS disarm the machine before any loading, adjustment or maintenance.

ALWAYS load clays from rear and **ONLY** if the machine is disarmed and safe.

NEVER approach the machine from the front or sides. **ALWAYS** from the rear.

NEVER allow children or untrained persons to approach or touch the machine.

NEVER move an armed/loaded machine. **ALWAYS** disarm and disconnect battery.

REMOVE the main throwing spring before transport in a vehicle.

BE AWARE of the fall zone of both broken and unbroken clays and that a change in wind direction will affect this.



EYE PROTECTION MUST BE WORN WHEN WORKING ON OR AROUND A CLAY TARGET LAUNCHER AS SMALL SHARP PIECES OF CLAY MAY BE EJECTED DURING NORMAL USE.



Falcon 6 & 8 stack Carousel Timing Method.

The reason the carousel timing is important is that the clay must be moved over the top plate drop hole in order for it to drop onto the casting plate. This must be done during the firing / reloading cycle, but before the throwing arm returns to its pre-firing position.

1. Make the trap safe by nudging the trap until it fires. Continue to nudge until the gearbox clamp block and the crank are in line with each other and the gearbox crank pointing toward the rear of the machine.

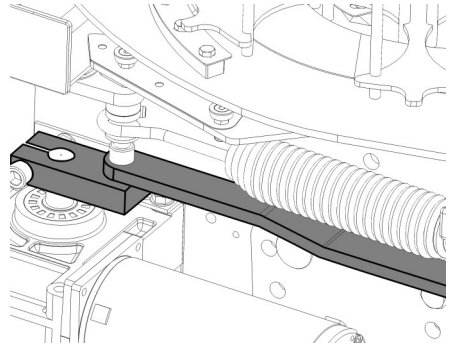

2. Disconnect the power to the trap.

3. Slacken the rear pusher clamp block bolt.

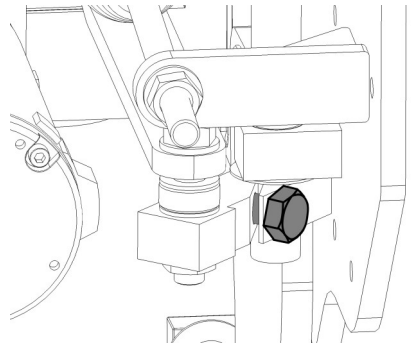

4. Rotate the rear pusher anti-clockwise (when viewed from above) until the nylon roller is just clear (2-3mm gap) inside the notch at the rear of the top plate.

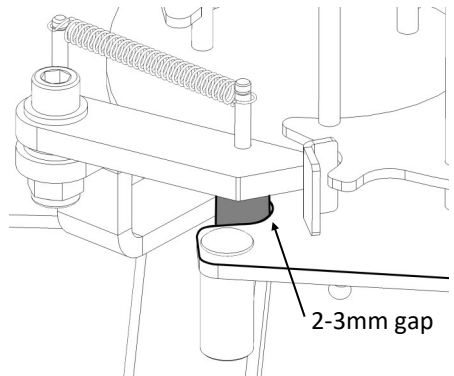

5. Tighten the rear pusher clamp block bolt

6. Test the machine.



Promatic International Ltd.

**Hooton Road
Hooton
South Wirral
CH66 7PA
United Kingdom**

Tel: +44 (0) 151 327 2220 (General)
+44 (0) 1407 860800 (Sales)
Fax: +44 (0) 151 3277075

E-mail info@promatic.co.uk

Website: www.promatic.co.uk

**Promatic Inc.
801, Mid America Drive,
Plattsburg,
MO 64477
USA**

Toll Free: 888.767.2529
Fax: 816.539.0257

E-mail: sales@promatic.biz

Website: www.promatic.biz