

# ELECTRIC ANCHOR WINCH BUNDLES

WORLD CLASS STAINLESS STEEL CHANDLERY AND BOATING ACCESSORIES

## Viper PRO SERIES II 1000 ELECTRIC ANCHOR WINCH BUNDLE

Introducing The World's First Submersible Stainless Steel Anchor Winch!

The Viper Pro Series II has set new standards in anchoring systems. Its marine grade stainless steel electric submersible motor has made it one of best selling anchor winch in Australia. With a fall rate of 45 meters per minute and a retrieval rate of over 40mtrs per minute the Viper will ensure you get onto your GPS mark, first time, every time! With unsurpassed Viper reliability, it has twice the torque of a conventional drum winch, 3 stainless steel support bearings on the 1 piece solid shaft and a 90 degree welded housing bracket which closes up the gap between your drum preventing your rope from jamming between the two. With also a life time warranty against water intrusion, and a bullet proof 5-year Viper performance warranty, you can't go past a Viper. Now supplied with everything you need to install it, including a 5mm stainless steel sandwich bracket, all required stainless steel bolts/screws and 2 face plates depending on dash room. All you have to add is your own cabling or our custom made Bell Marine tinned copper wiring loom, you will never have to break your back pulling up your anchor and chain again!

## When Performance Matters!

As fast as free-fall but without the STRESS!

**5 YEAR WARRANTY  
LIFETIME WATER  
INTRUSION WARRANTY**

**WORLD'S FIRST  
SUBMERSIBLE  
DRUM WINCH**

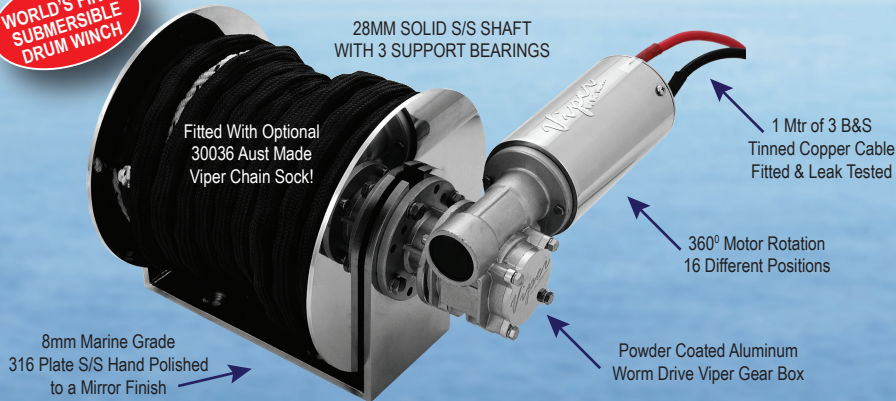

P/N	30021-8	VIPER PRO SERIES II 1000 WINCH BUNDLE 75MTRS 3 STRAND ROPE	RRP \$1545.
P/N	30021-6	VIPER PRO SERIES II 1000 WINCH BUNDLE 100MTRS D/BRAID ROPE	RRP \$1545.
P/N	30021-5	VIPER PRO SERIES II 1000 WINCH BUNDLE 200MTRS UHMWPE ROPE	RRP \$1995.

### INCLUDED IN THE PRO SERIES II 1000 BUNDLE:

- 30021 - VIPER PRO SERIES II 1000 SUBMERSIBLE ANCHOR WINCH SUPPLIED WITH 1 MTR 3 B&S POWER LEADS & JOINING CONNECTORS PRESSURE TESTED & SEALED
- 30010 - 75MTRS OF 8MM TRIPLE STRAND PREMIUM ROPE
- 8 MTRS OF 6MM GALVANISED SHORT LINK ANCHOR CHAIN
- 30001 - VIPER PRO SERIES ANCHOR SWIVEL - SMALL
- 30009 - VIPER DELUXE ANCHOR ROLLER - SMALL
- 30020 - 200AMP REVERSING SOLENOID
- 90021 - LED ILLUMINATED MARINE ROCKER SWITCH
- 90046 - VIPER LASER ETCHED LED ILLUMINATED SWITCH COVER
- 30046 - 100 AMP FLUSH MOUNT CIRCUIT BREAKER WITH RUBBER SEAL
- 30051 - SINGLE LED SWITCH STAINLESS STEEL FACE PLATE
- 30052 - COMBO LED SWITCH & CIRCUIT BREAKER S/S FACE PLATE
- 5MM STAINLESS STEEL SANDWICH PLATE
- ALL FIXING HARDWARE
- INSTALLATION NOTES & WIRING DIAGRAM

MAX FALL RATE:	45MTRS PER MINUTE
MAX RETRIEVAL RATE:	41MTRS PER MINUTE
SUIT VESSEL LENGTH:	5.7 MTRS +
MAX LOAD:	195KGS
WEIGHT:	15KGS

### PACKAGING:

WINCH BOX:	49 X 49 X 34 CM	20KG
ROPE KIT:	25 X 25 X 25 CM	9KG

### OPTION'S:

30021-A ALLOY FITMENT KIT FOR ALUMINIUM BOAT INSTALLATIONS	RRP \$ 35.
30036 - 10MTRS OF CHAIN SOCK TO SUIT 6MM SHORT LINK CHAIN	RRP \$ 39.
30023 - SMALL ROUND HAWSE PIPE FOR TRICKY INSTALLATIONS	RRP \$139.
30057 - 5MM HI SPEC 3000 UHMWPE ROPE KIT - 200MTRS 2050KG B/S	RRP \$539.
30006 - SINGLE ROLLER VIPER BOW ROLLER SELF-LAUNCHING	RRP \$259.
30016 - DELUXE 3 ROLLER VIPER BOW ROLLER- SELF LAUNCHING	RRP \$399.
30034 - CUSTOM MADE MARINE WIRING LOOM BOATS UPTO 6MTRS	RRP \$259.
30035 - CUSTOM MADE MARINE WIRING LOOM BOATS UPTO 8MTRS	RRP \$299.

### TECHNICAL SPECIFICATIONS

