

Köpenick

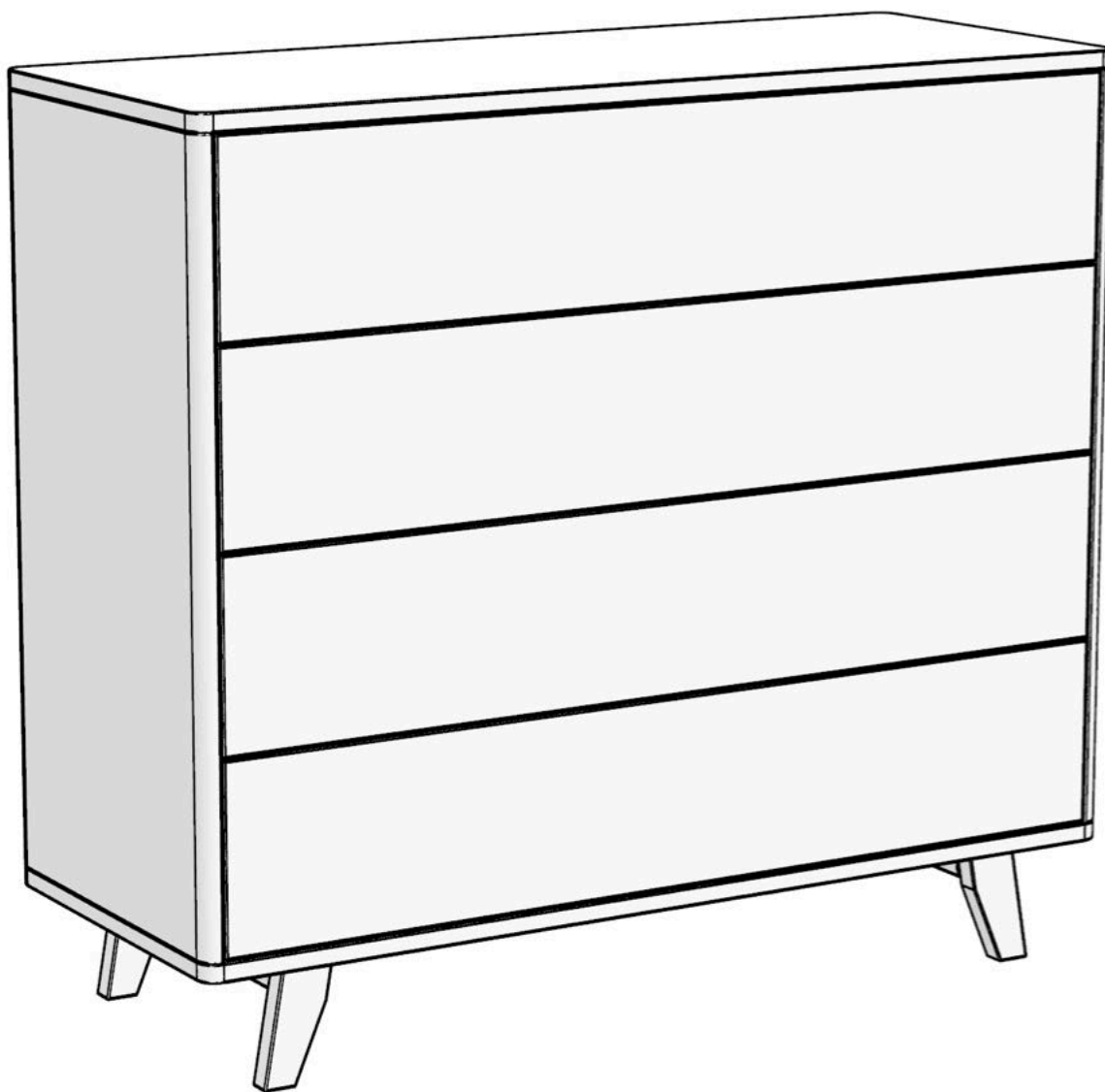

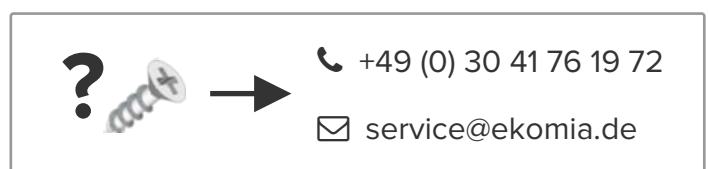

1

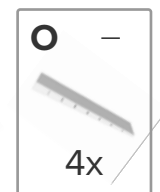
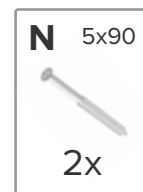
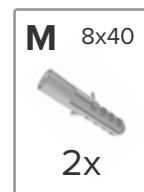
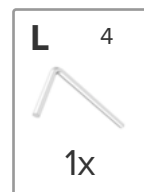
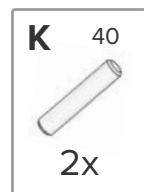
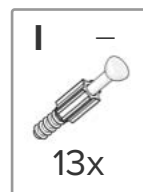
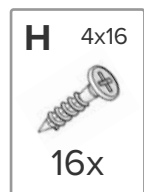
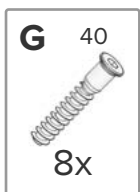
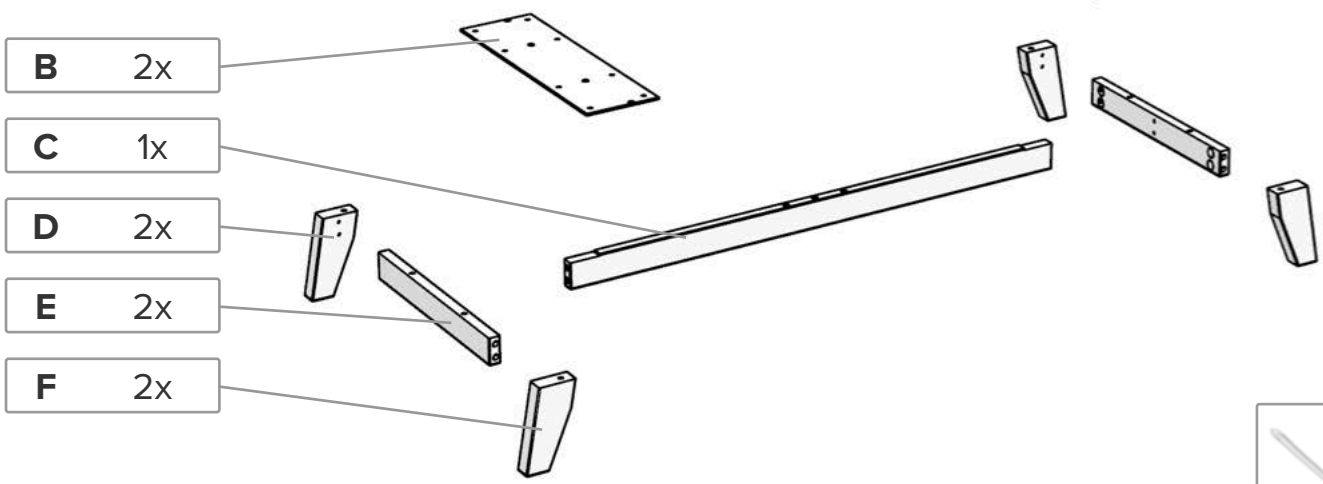
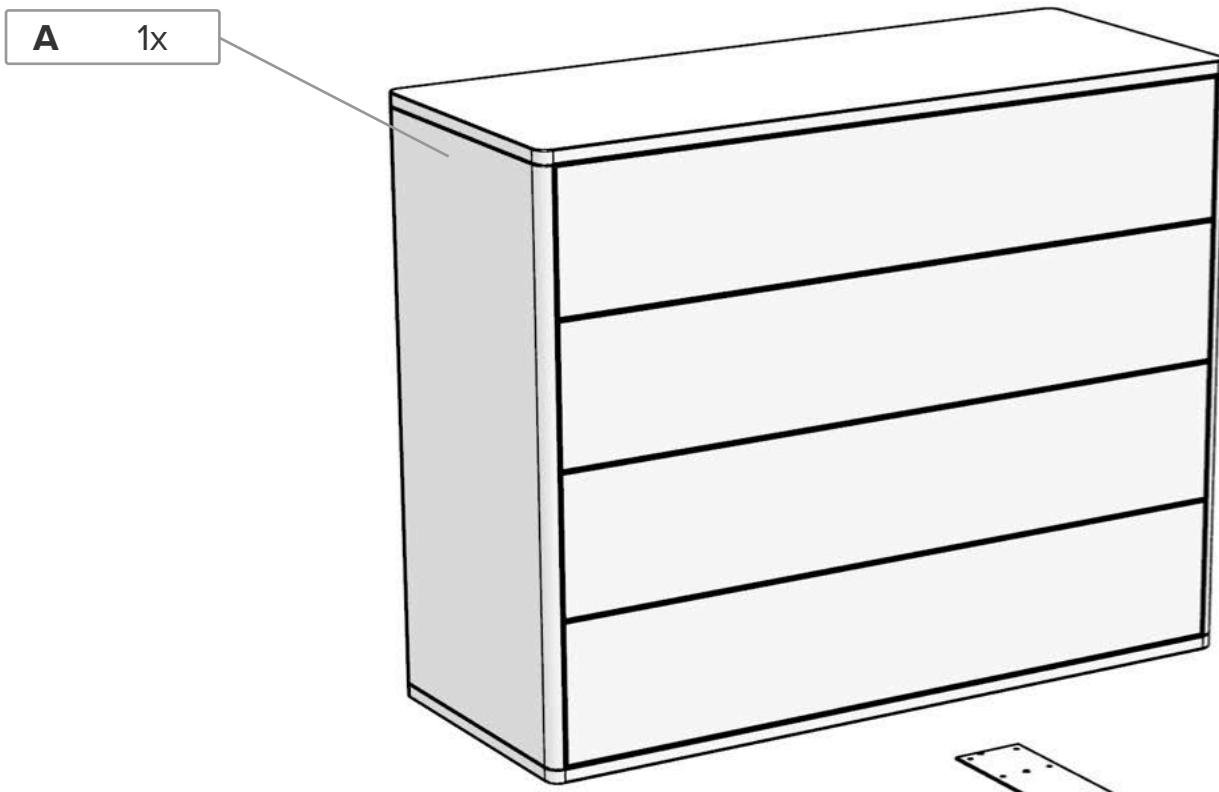
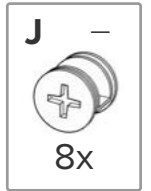
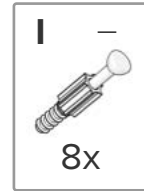
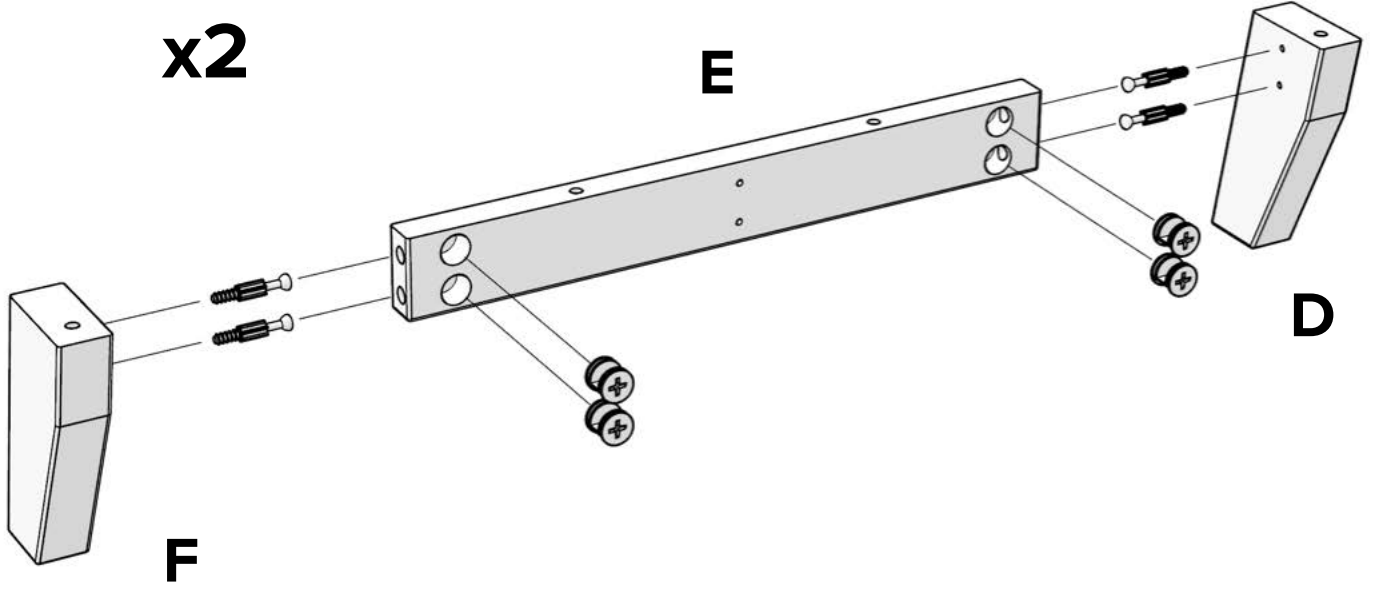

2

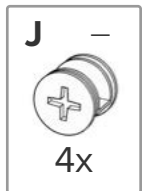
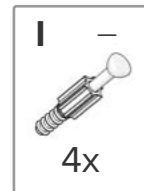
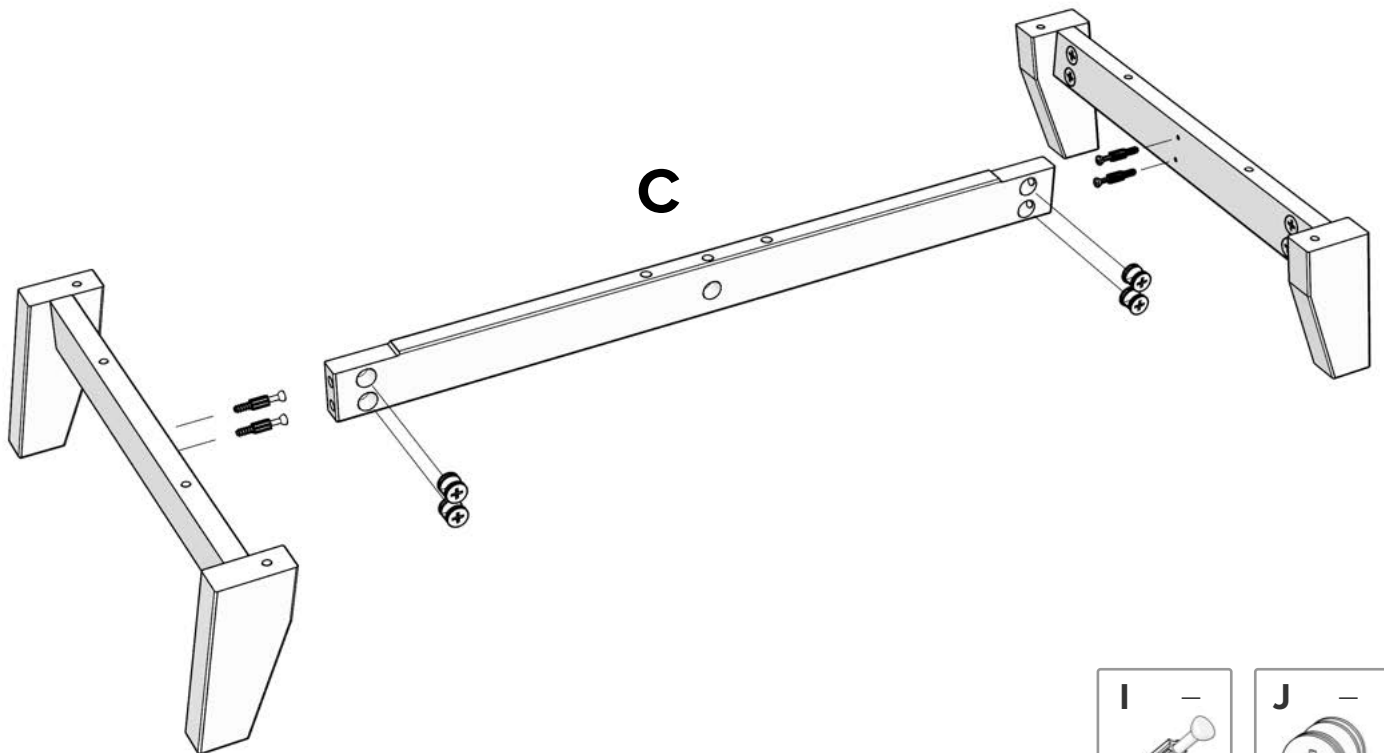

3

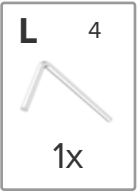
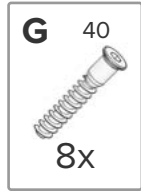
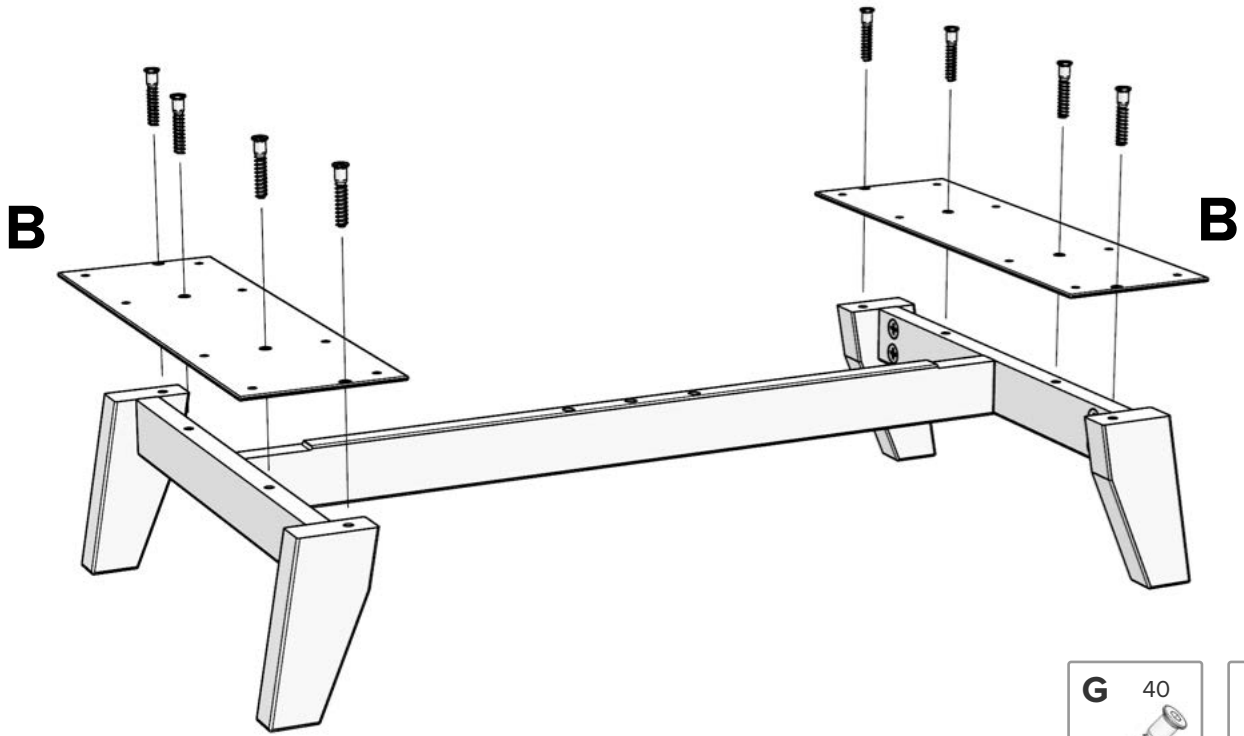

4

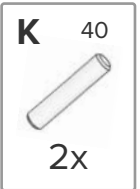
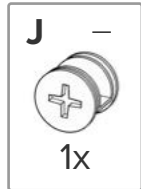
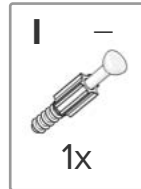
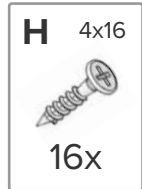
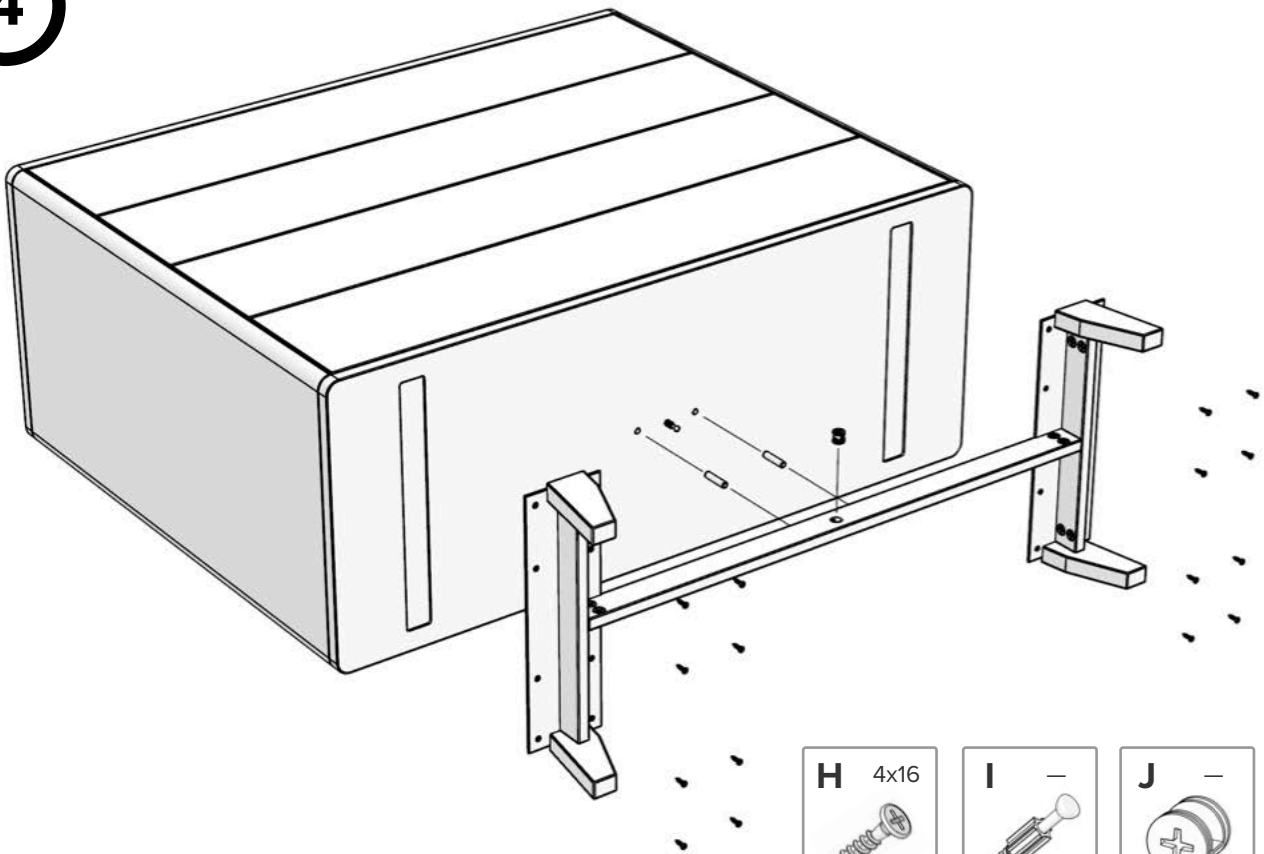

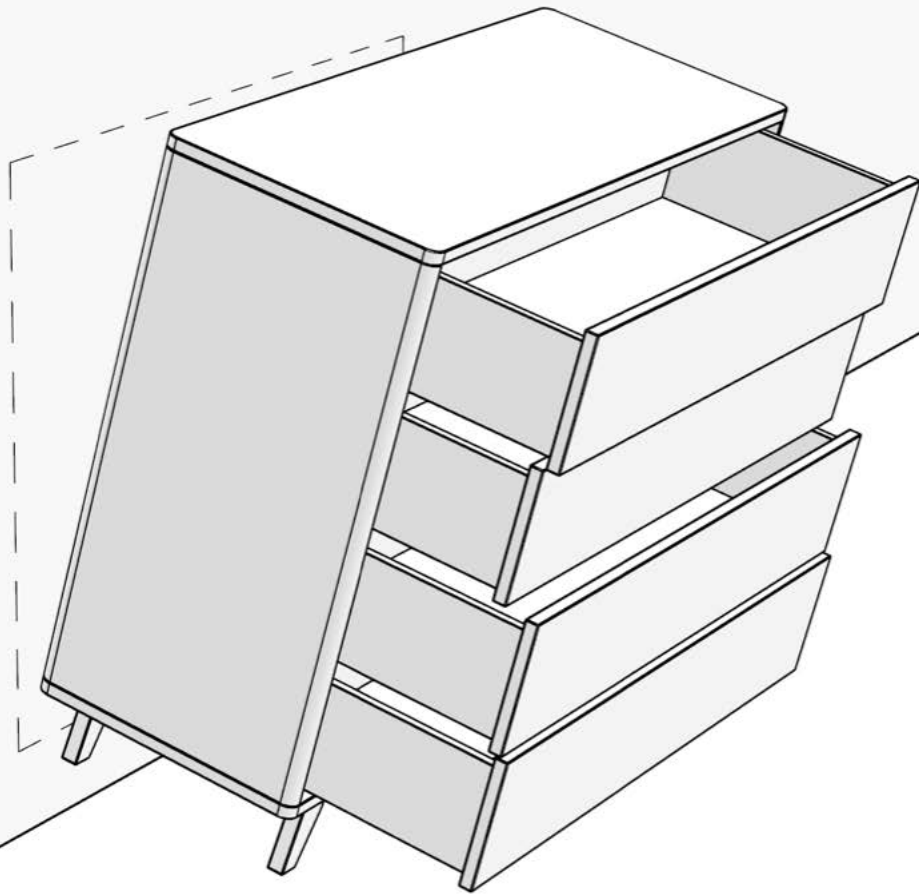

(DE) Achtung! Kippgefahr!

Die Kommode kann umkippen, wenn ein Ungleichgewicht entsteht. Es ist zwingend notwendig, die Kommode an der Wand zu befestigen. Befestige die Kommode mit den mitgelieferten Dübeln und Schrauben an der Wand.

(EN) Attention! Danger of tipping over!

The dresser can tip over if there is an imbalance. It is essential to fix the dresser to the wall. Fix the dresser to the wall with the dowels and screws provided.

(FR) Attention! Danger de basculement!

La commode peut se renverser en cas de déséquilibre. Il est essentiel de fixer la commode au mur. Fixez la commode au mur avec les chevilles et les vis fournies.

(NL) Attentie! Gevaar voor kantelen!

De ladekast kan omvallen als er een onbalans is. Het is essentieel om de commode aan de muur te bevestigen. Bevestig de ladekast aan de muur met de bijgeleverde pluggen en schroeven.

(IT) Attenzione! Pericolo di ribaltamento!

La cassetiera può ribaltarsi se c'è uno squilibrio. È essenziale fissare la cassetiera al muro. Fissare la cassetiera al muro con i tasselli e le viti in dotazione.

(ES) ¡Atención! ¡Peligro de volcar!

La cómoda puede volcarse si hay un desequilibrio. Es imprescindible fijar la cómoda a la pared. Fije la cómoda a la pared con los tacos y tornillos suministrados.

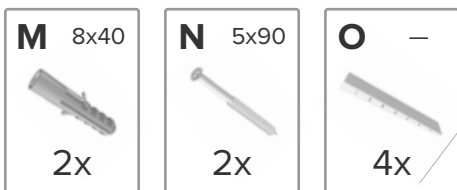

+49 (0) 30 41 76 19 72

service@ekomia.de

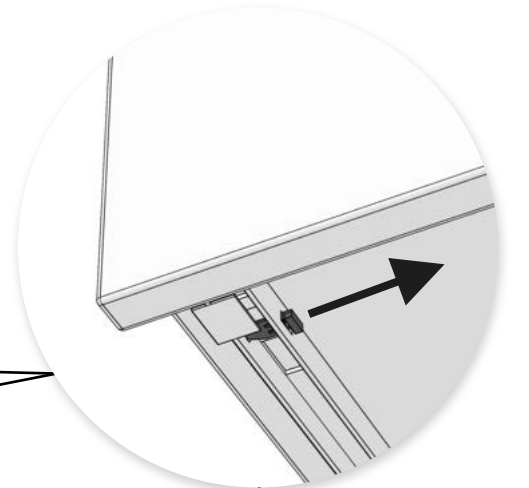
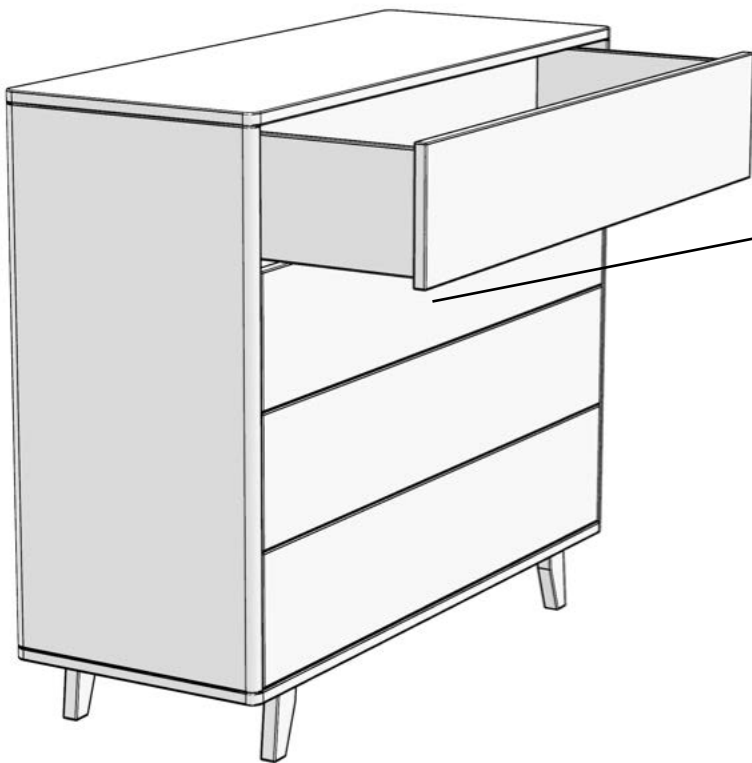
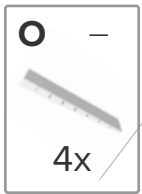
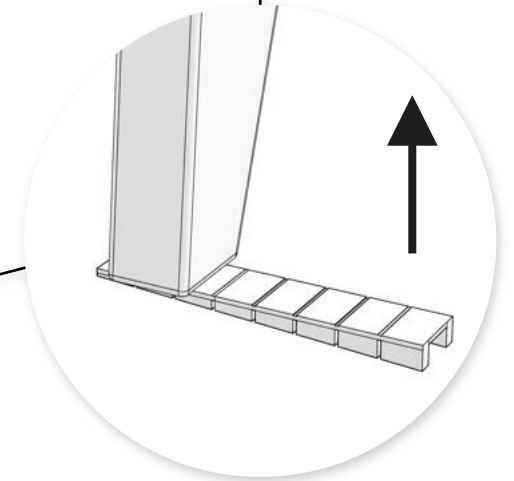
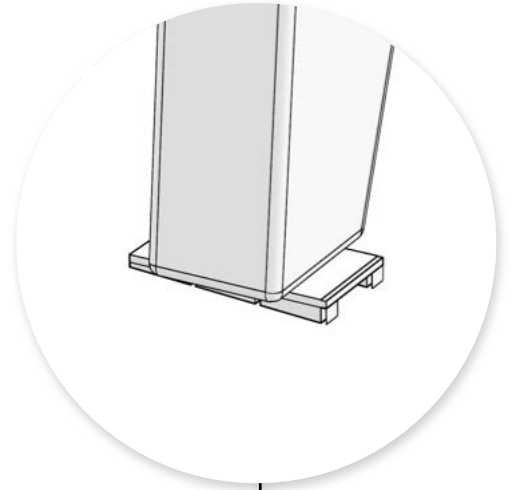
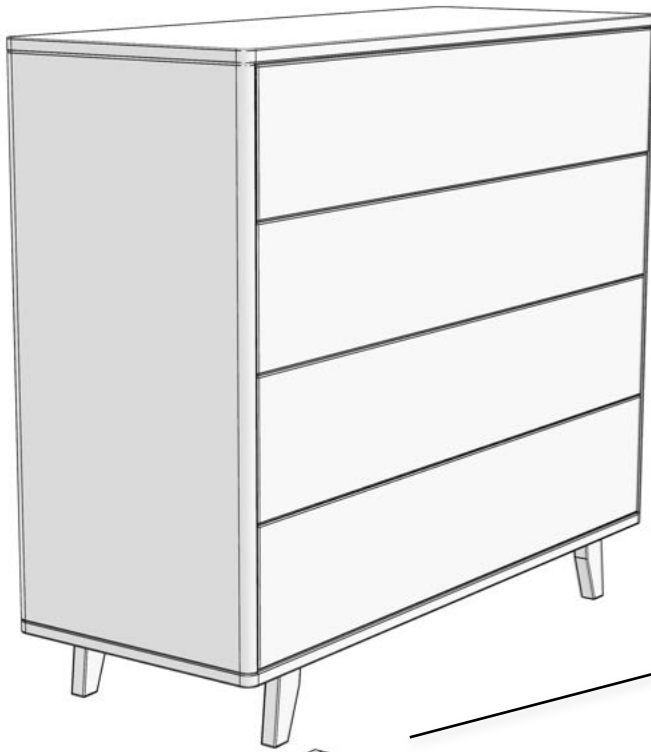

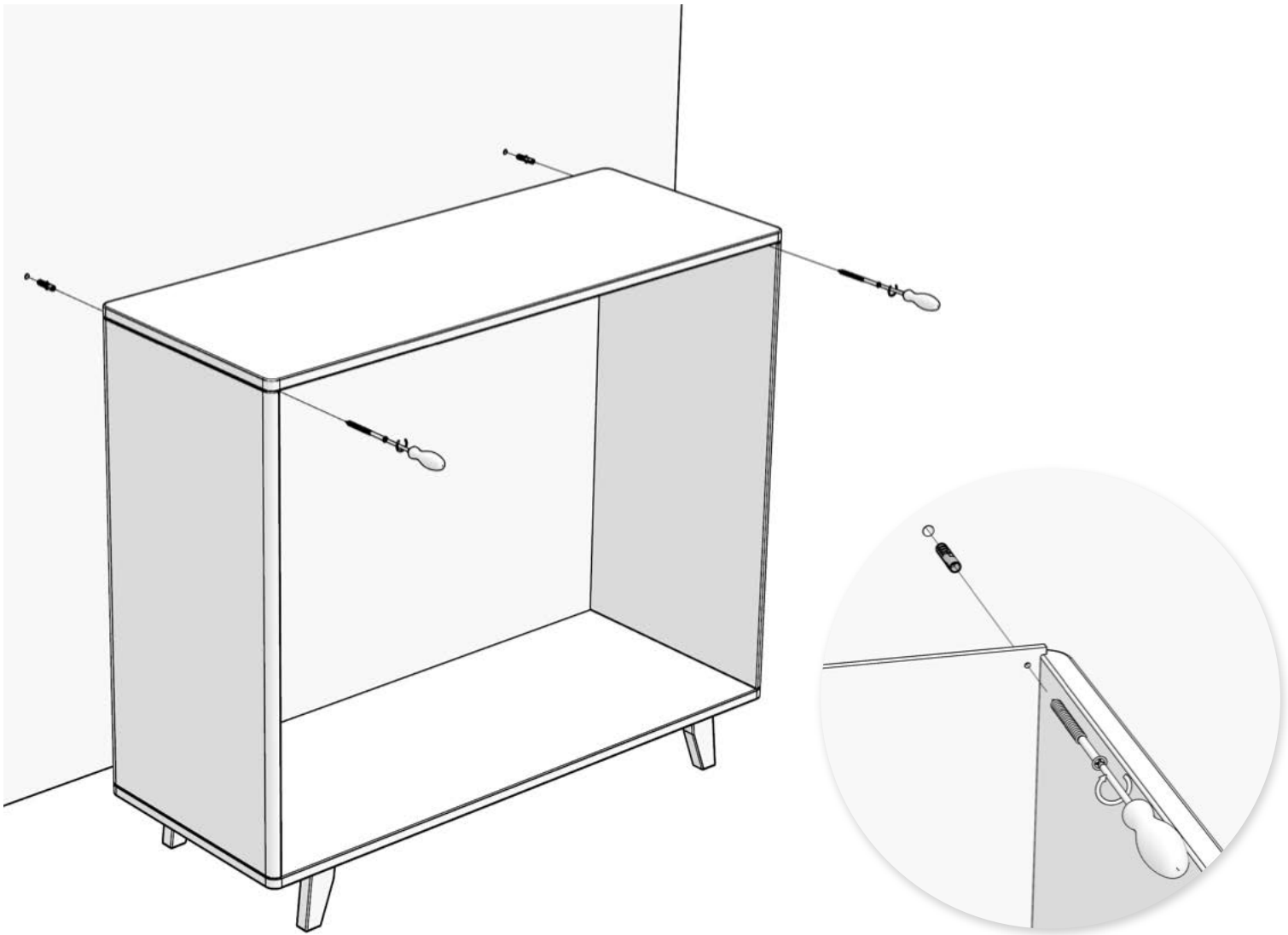
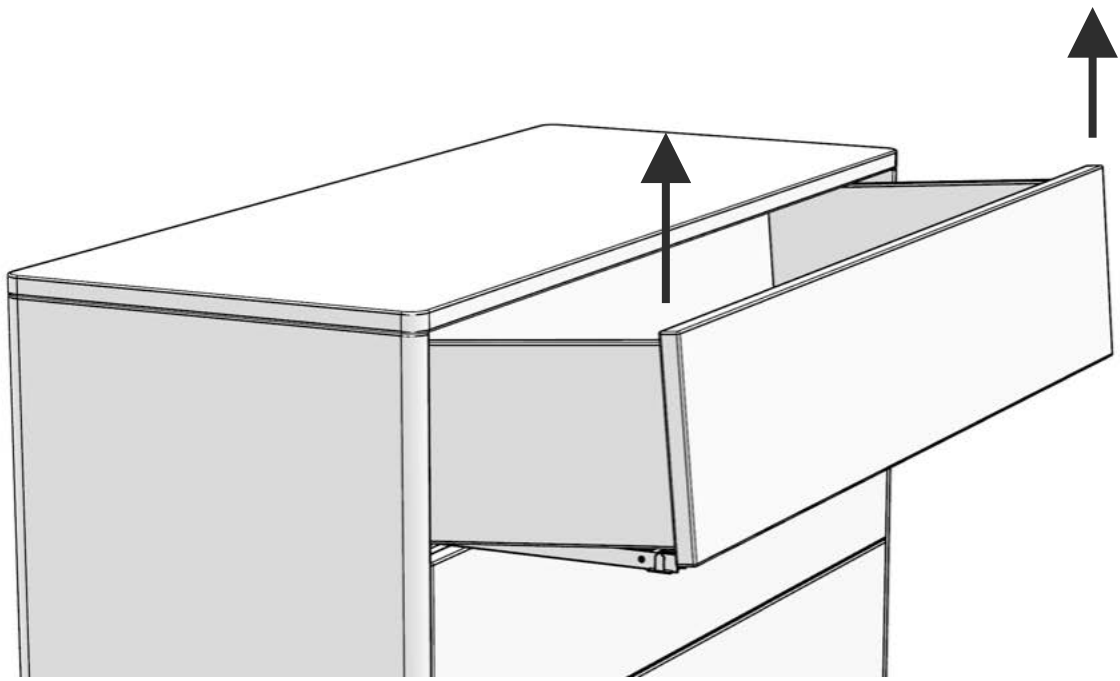

M 8x40

2x

N 5x90

2x

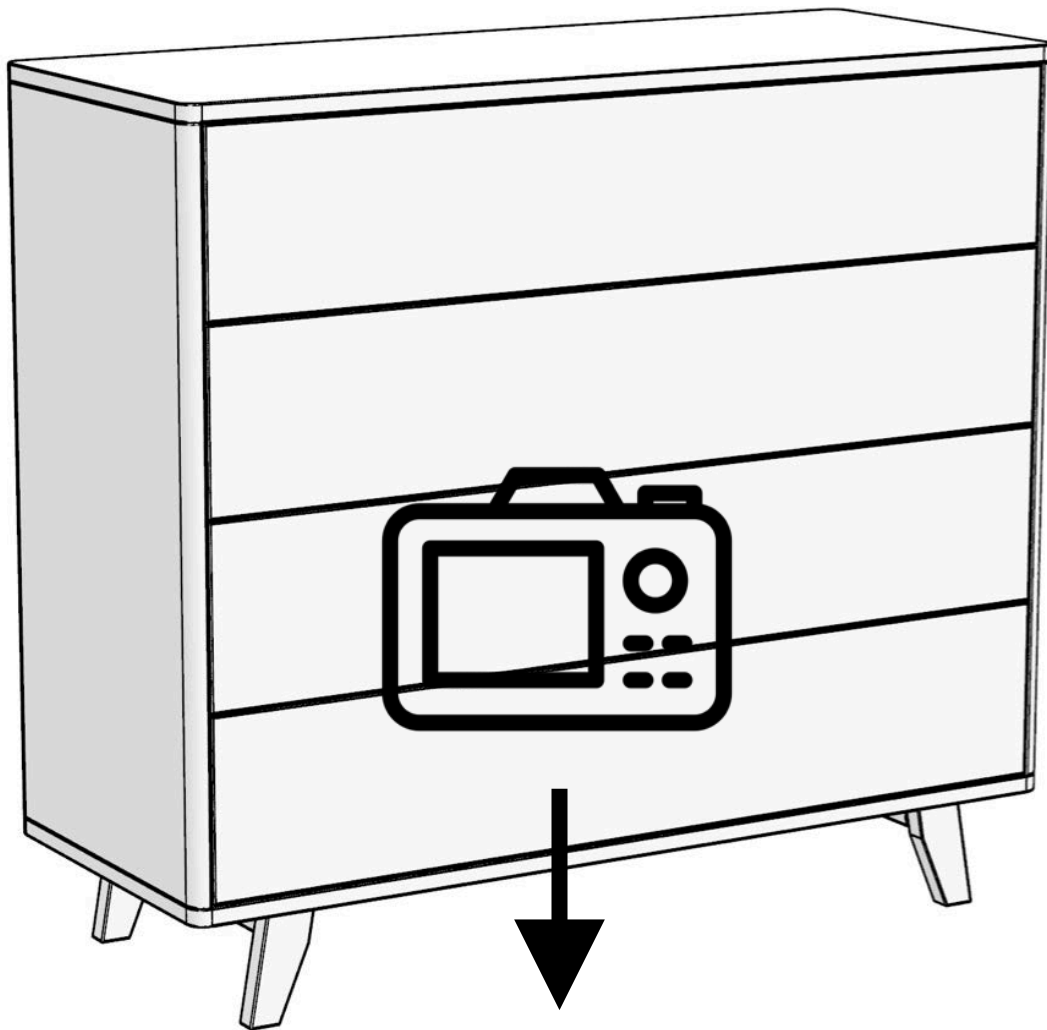
Chic!



fotos@ekomia.de



+49 (0) 30 41 76 19 72

ekomia.de

✉ service@ekomia.de

