

Enorm

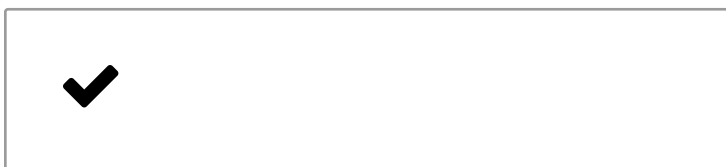

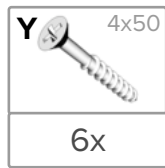
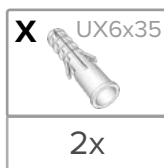
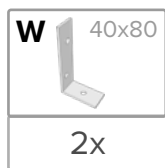
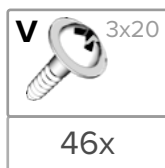
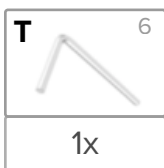
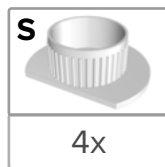
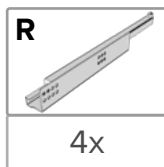
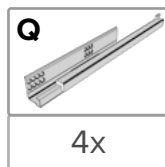
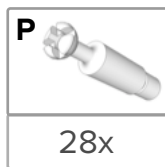
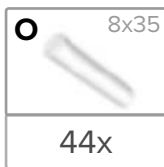
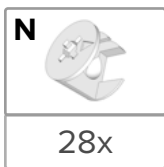
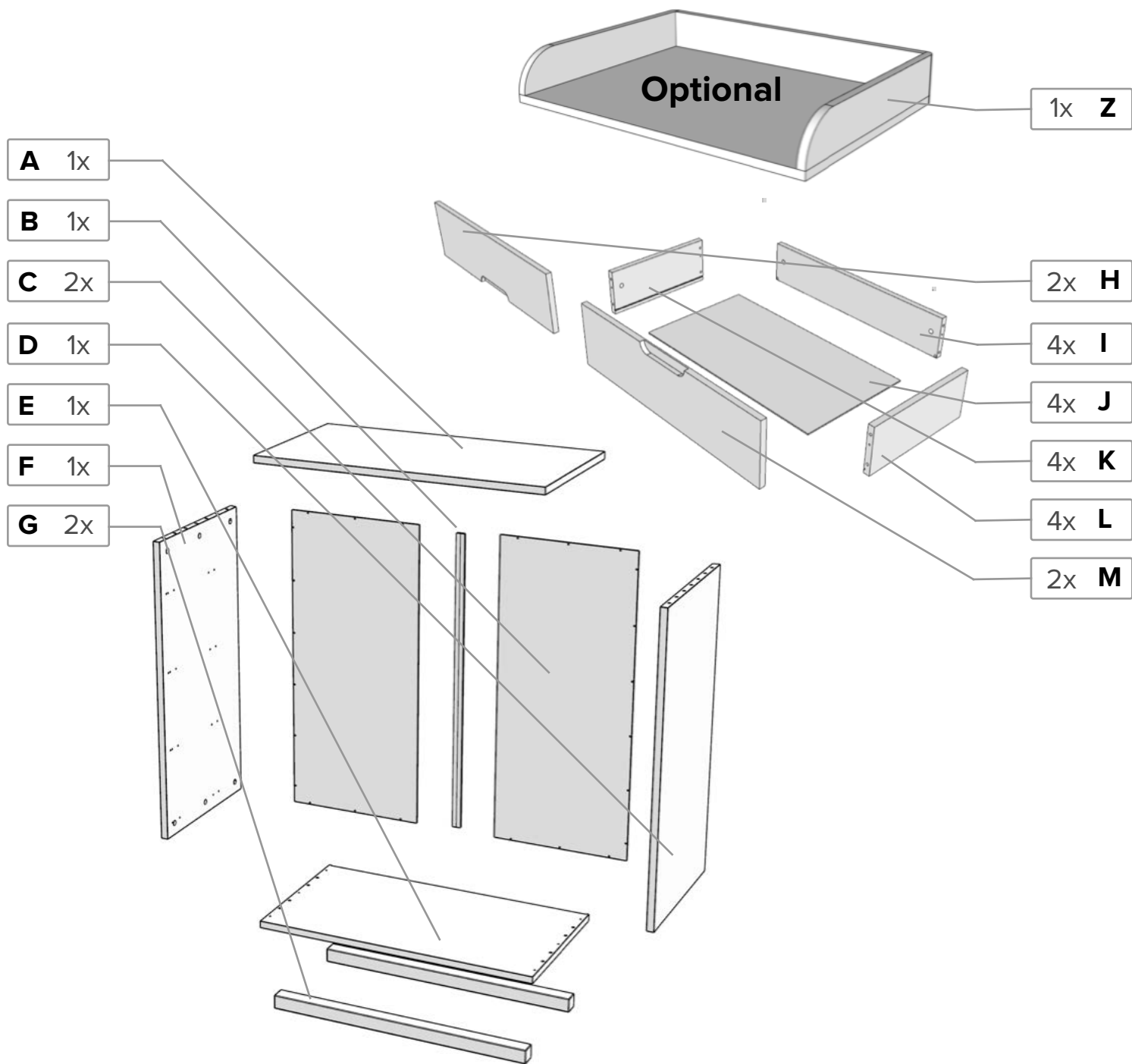

DE**WICHTIG – FÜR SPÄTERES NACHSCHLAGEN
AUFBEWAHREN – SORGFÄLTIG LESEN**

- a) WARNUNG: Lasse dein Kind nie unbeaufsichtigt.
- b) Ziehe alle Montagemittel immer ausreichend fest und überprüfe die Festigkeit regelmäßig;
- c) Denke an das Risiko von offenem Feuer und anderen starken Wärmequellen in der unmittelbaren Umgebung der Wickeleinrichtung, wie elektrische Heizstrahler, gasbeheizte Öfen usw.;
- d) Die Wickelablage ist für Kinder bis 15 kg Körpergewicht (ohne Kleidung) geeignet.
- e) Alle zusätzlichen Teile oder Ersatzteile dürfen nur von ekomia GmbH bezogen werden;
- f) Die Wickeleinrichtung darf nicht benutzt werden, wenn irgendein Teil defekt ist, abgerissen ist oder fehlt.

Dieser Wickeltisch Enorm (ST0172W+ST0175W) wurde nach der Norm DIN EN 12221-1:2008+A1:2013 (Wickeleinrichtungen für den Hausgebrauch) von ekomia GmbH entwickelt und produziert.

**EN****IMPORTANT - KEEP FOR FUTURE REFERENCE - READ CAREFULLY**

- a) WARNING: Never leave your child unattended.
- b) Always tighten all fittings sufficiently and check regularly that they remain tight;
- c) Think about the risk of open fire and other sources of intense heat such as electric heaters, gas heaters etc. in the immediate vicinity of the changing equipment;
- d) The changing mat is suitable for children weighing up to 15 kg (without clothes).
- e) Additional or replacement parts may only be purchased from ekomia GmbH;
- f) The changing equipment may not be used if any part is broken, torn off or missing.

This Enorm changing table (ST0172W+ST0175W) was designed and manufactured by ekomia GmbH in accordance with DIN standard EN 12221-1:2008+A1:2013: (changing equipment for domestic use).

FR**IMPORTANT - CONSERVER POUR CONSULTATION ULTERIEURE - LIRE ATTENTIVEMENT**

- a) AVERTISSEMENT: Ne laissez jamais votre enfant sans surveillance.
- b) Assemblez toutes les pièces de montage toujours suffisamment et vérifiez régulièrement leur stabilité;
- c) Pensez au risque de feu de cheminée ou d'autres sources de chaleur intense dans le voisinage immédiat du dispositif pour changer les bébés, comme les radiateurs électriques, fours à gaz.
- d) La table pour changer les bébés pour seulement être utilisée avec le lit d'enfant Lumy d'ekomia. Le plateau d'enroulement ne peut être inséré à fleur avec les parties d'extrémité sur le lit Lumy dans les trous prévus à cet effet.
- e) Fixez toujours le dispositif pour changer les bébés avec des fermetures de sécurité. Assurez-vous que les joints s'intègrent toujours étroitement;
- f) Le plateau pour changer les bébés est adapté pour les enfants d'un poids corporel allant jusqu'à 15 kg (sans vêtements).
- g) Toutes les pièces supplémentaires ou les pièces de rechange peuvent seulement être achetées chez ekomia SARL;
- h) Le dispositif pour changer les bébés ne peut pas être utilisé si une pièce est cassée, déchirée ou manquante.

Ce dispositif Enorm pour changer les bébés (ST0172W+ST0175W) a été développé et fabriqué selon la norme DIN EN 12221-1:2008+A1:2013 (Directives pour l'usage domestique relatives aux produits pour changer les bébés) par la SARL ekomia.

NL**BELANGRIJK - BEWAAR VOOR DE TOEKOMST - LEES ZORGVULDIG**

- a) WAARSCHUWING: laat uw kind nooit zonder toezicht.
- b) Trek de bevestigingsmiddelen altijd voldoende sterk aan en controleer de vastheid ervan regelmatig;
- c) Denk aan het risico van open vuur en andere sterke warmtebronnen in de nabijheid van het luiergedeelte, zoals elektrische kachels, gasovens etc.;
- d) Het luiergedeelte is geschikt voor kinderen met een lichaamsgewicht (zonder kleren) tot 15 kg.
- e) Alle extra stukken of reserveonderdelen mogen alleen aangeschaft worden bij ekomia GmbH;
- f) Het luiergedeelte mag niet gebruikt worden als er een onderdeel gebroken of gescheurd is of ontbreekt.

Dit luiergedeelte "Enorm" (ST0172W+ST0175W) is volgens de norm DIN EN 12221-1:2008+A1:2013 (luiervoorzieningen voor huishoudelijk gebruik) ontwikkeld en geproduceerd door ekomia GmbH.

1

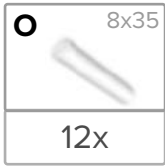
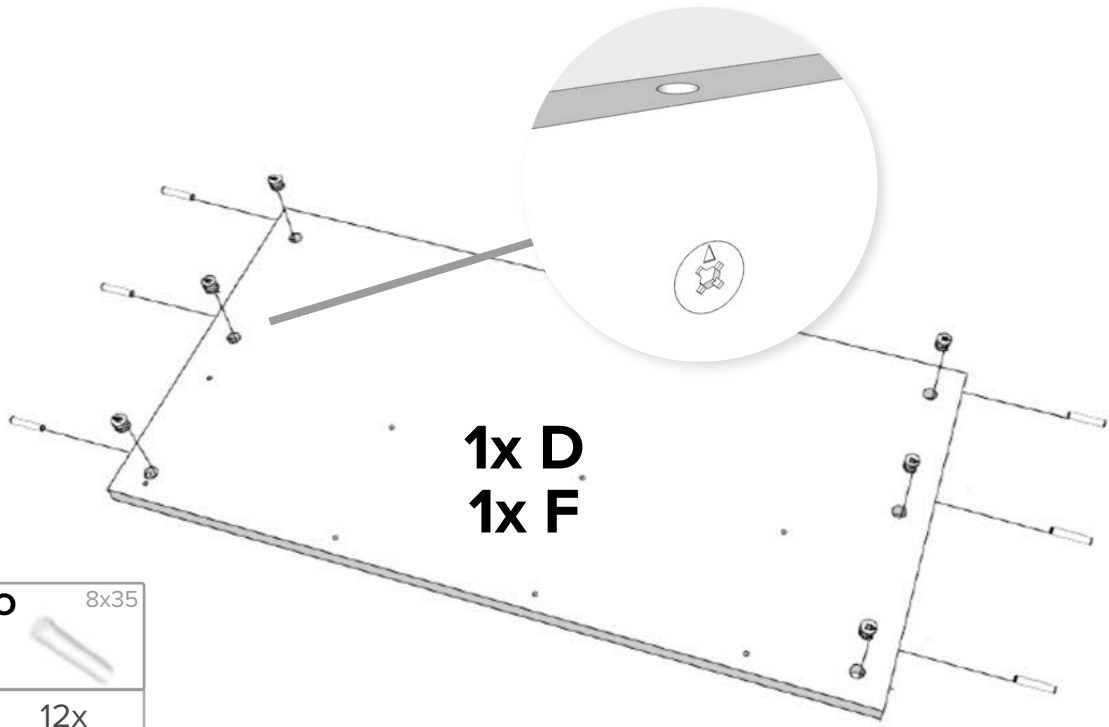

2

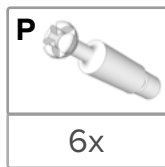
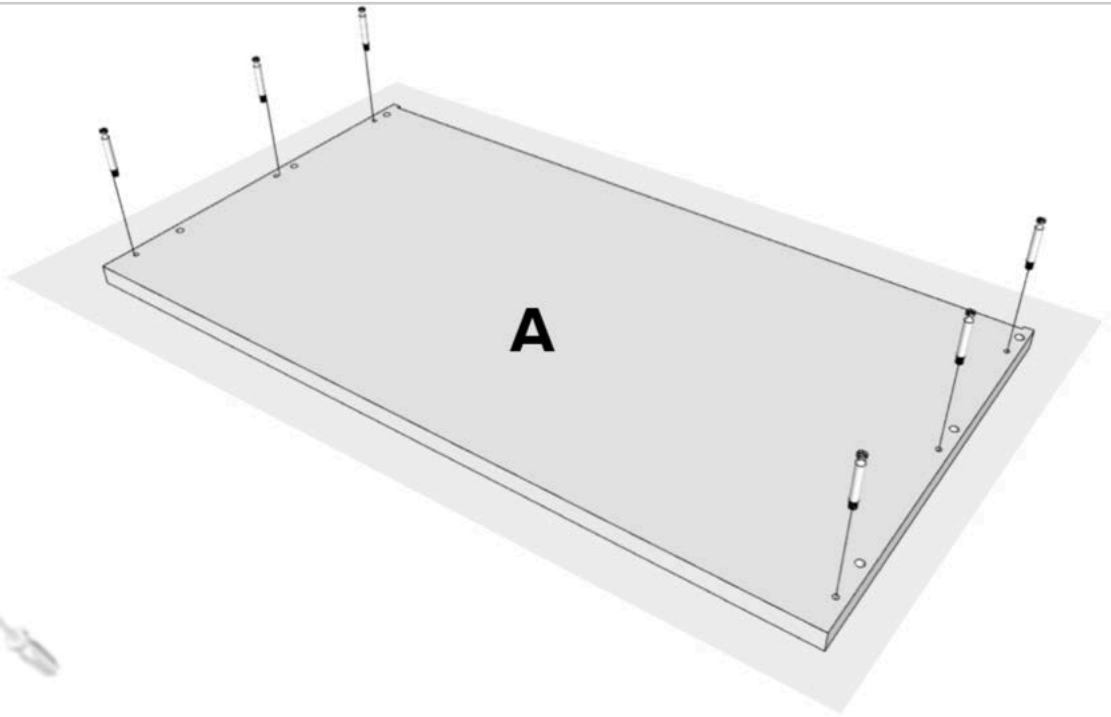

3

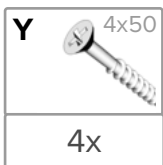
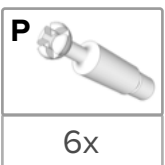
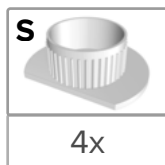
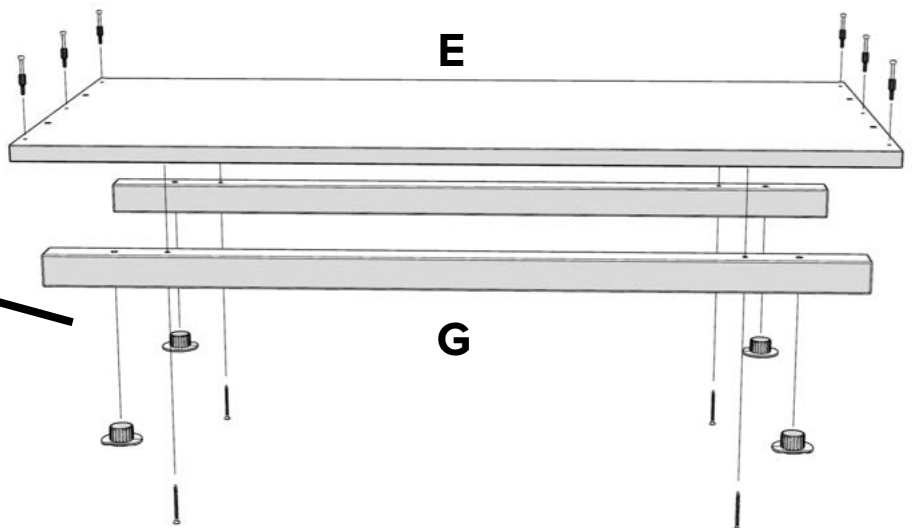
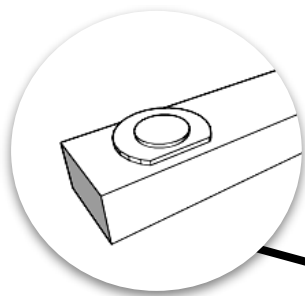

4

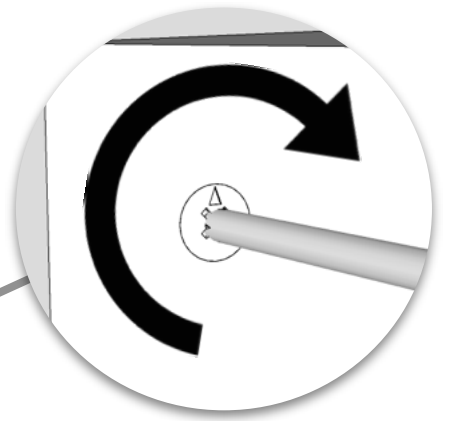
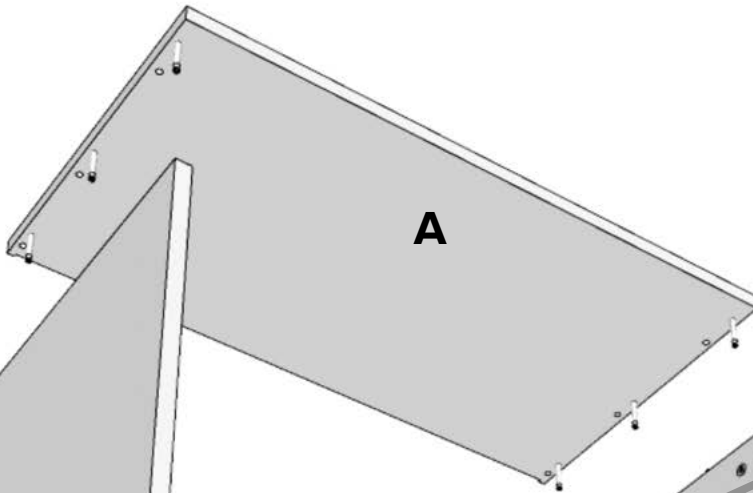
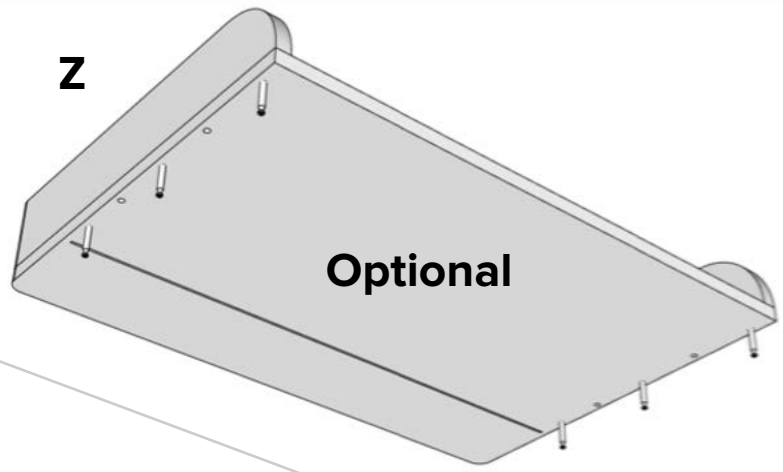

F

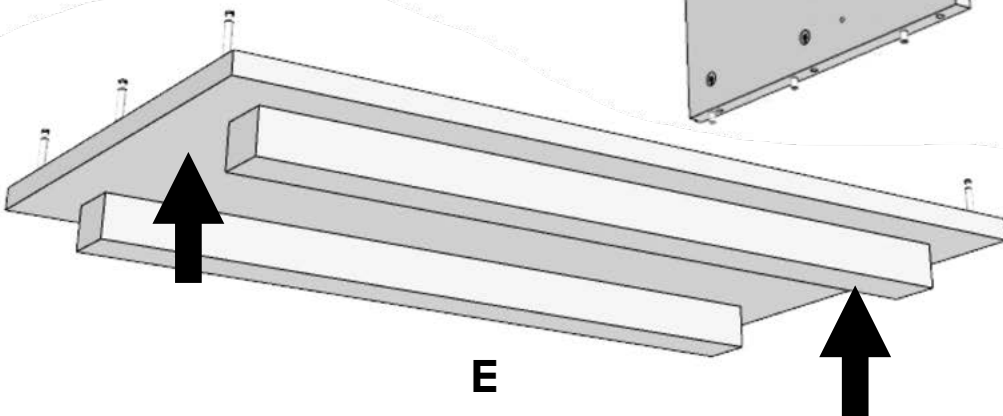
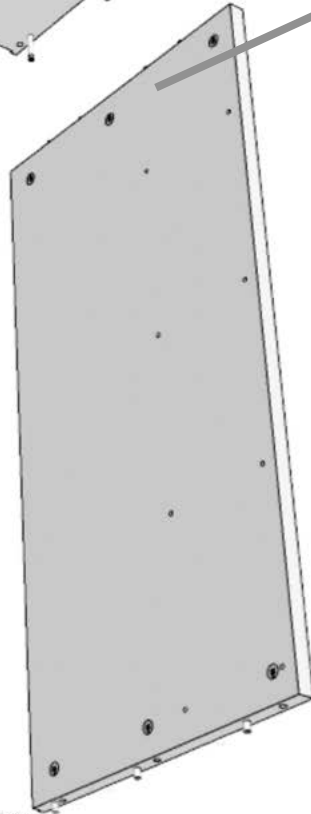
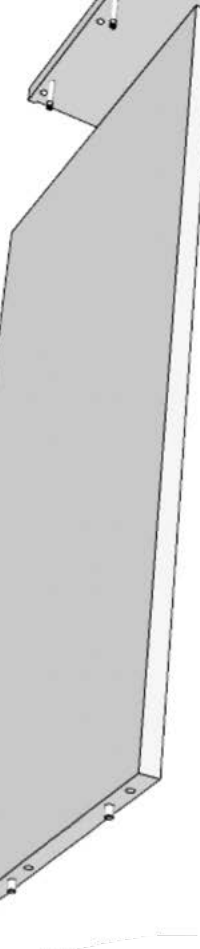

5

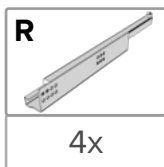
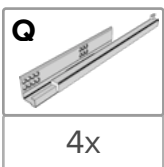
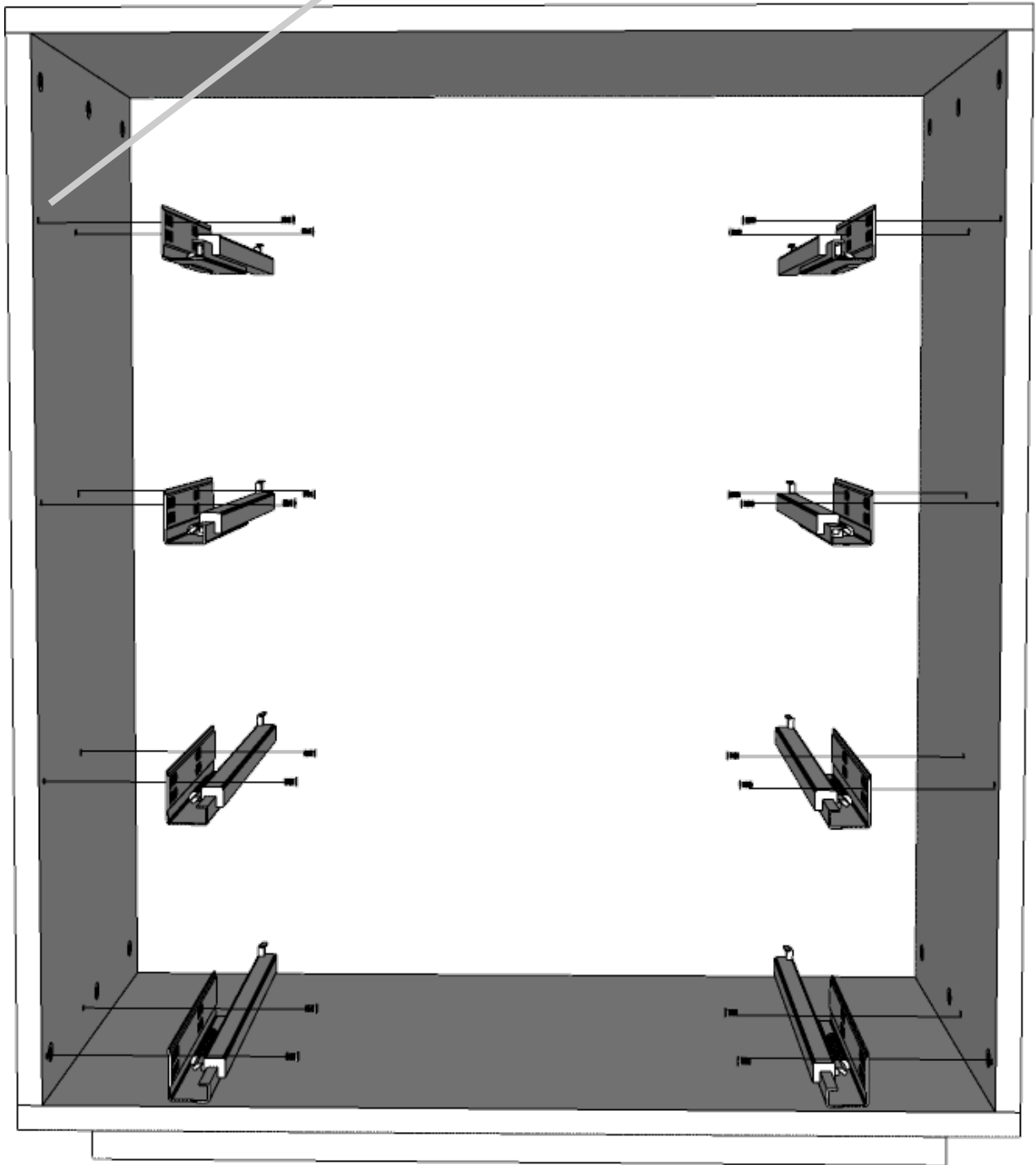
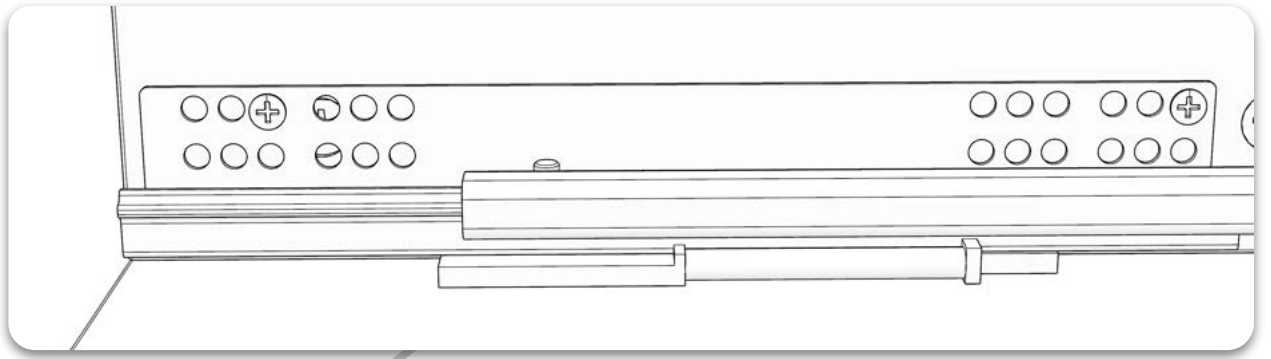

6

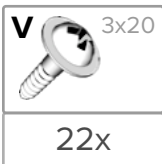
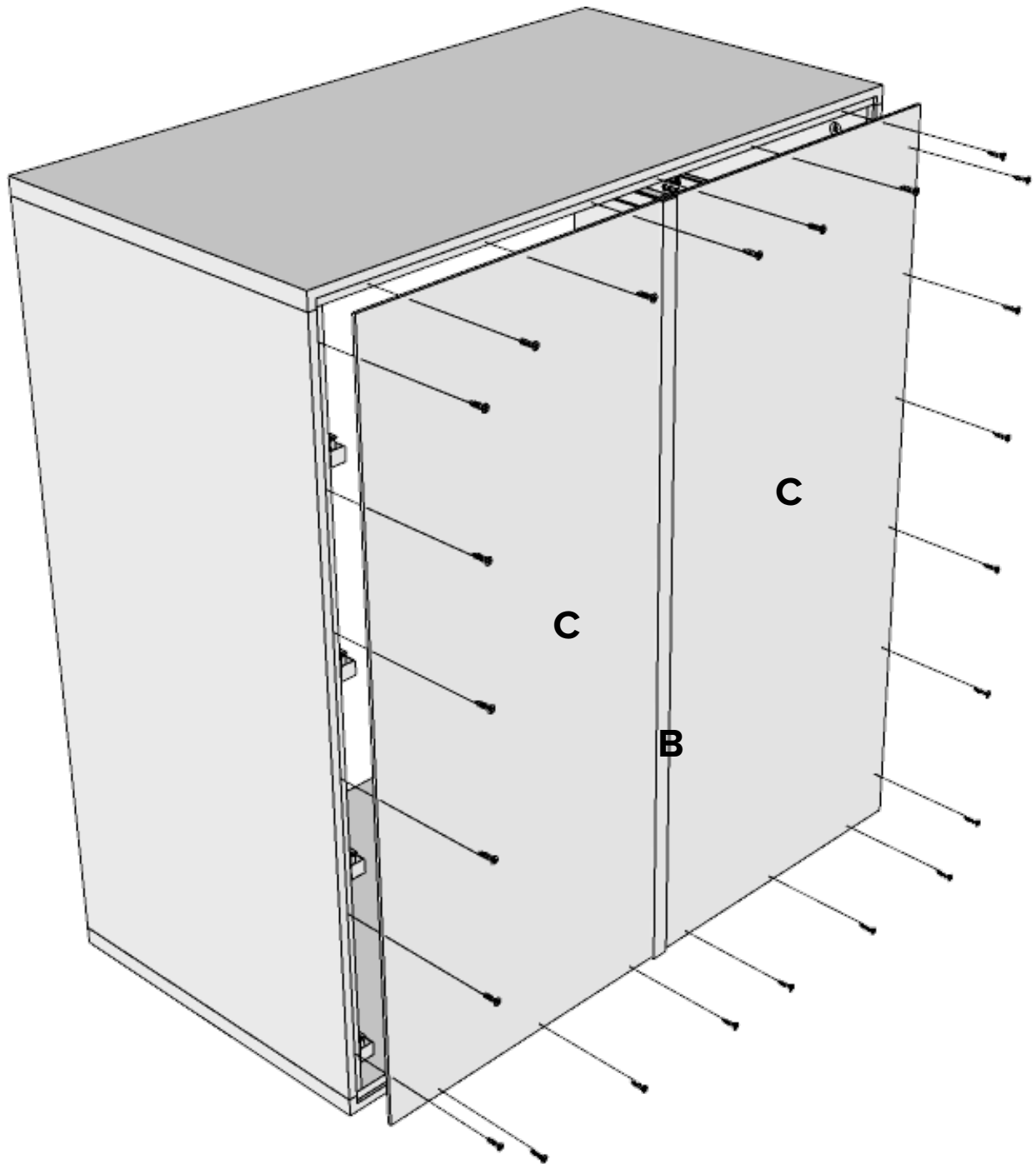

7

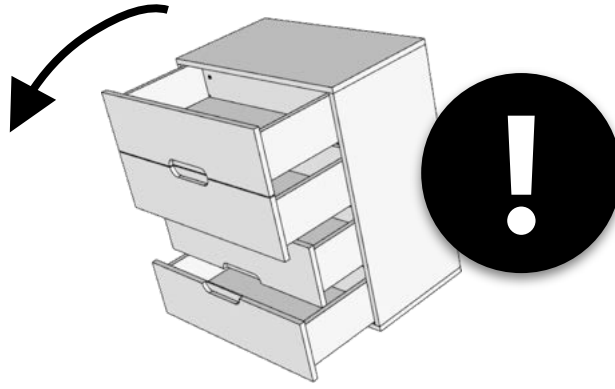

a

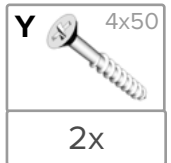
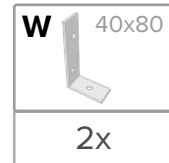
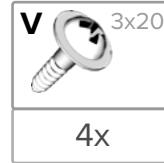

b

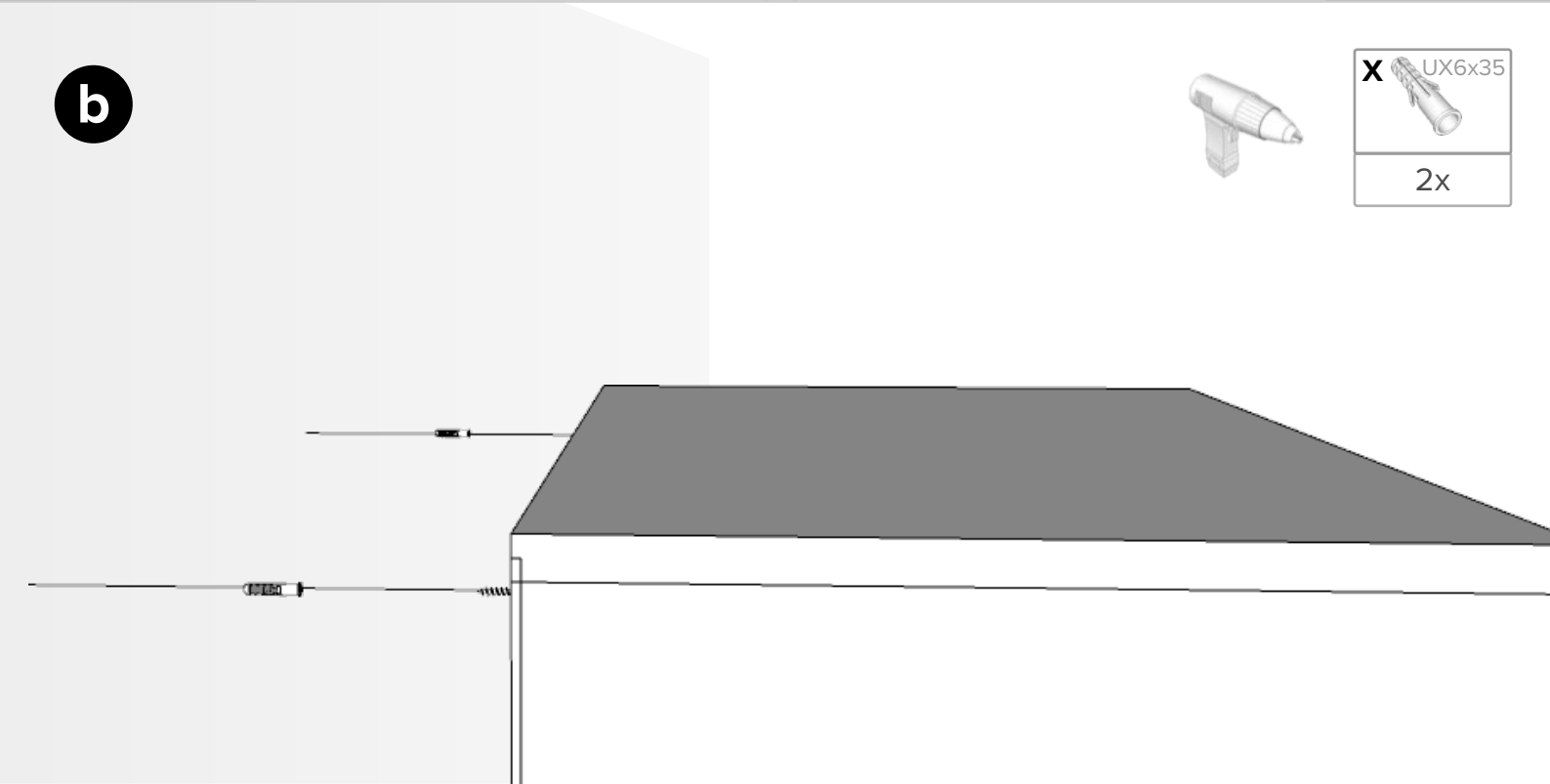

8

Optional

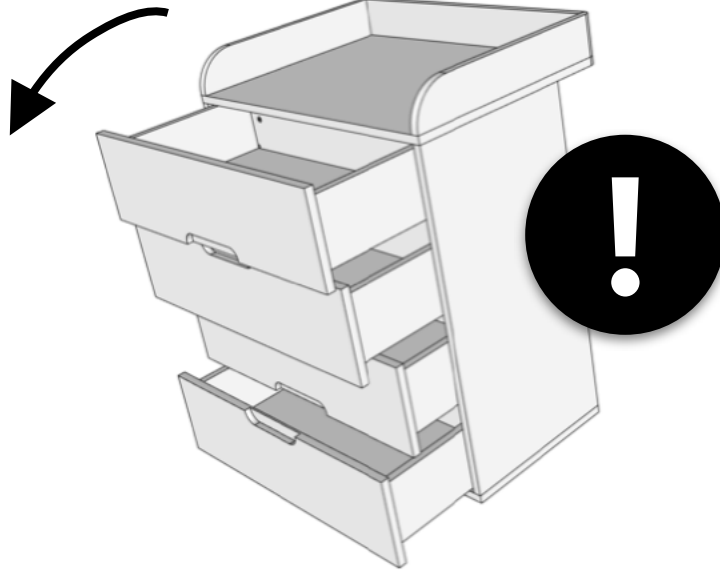

a

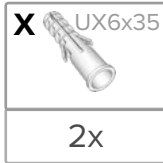
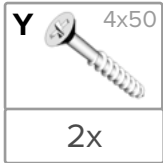
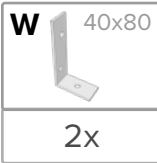
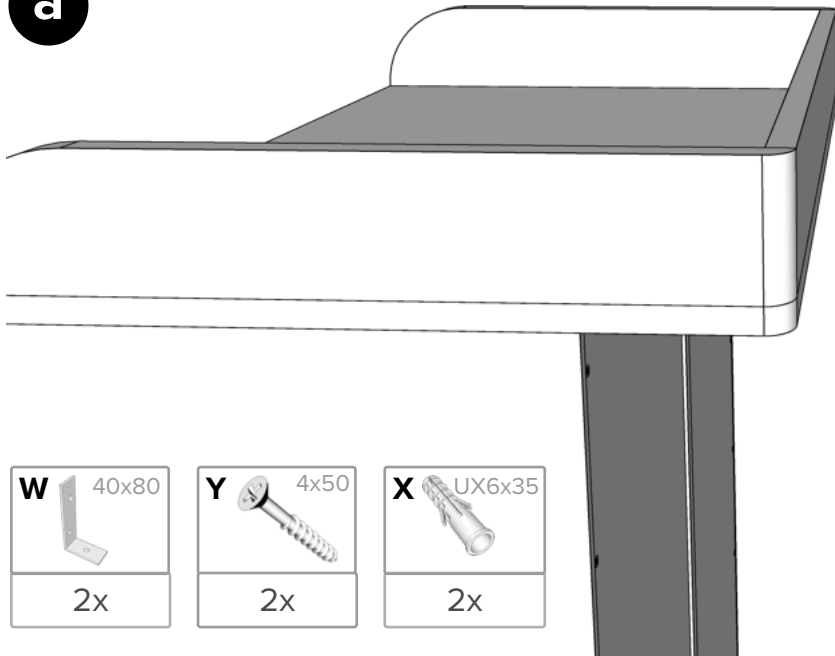

b

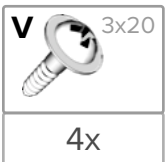

9

4x K
4x L

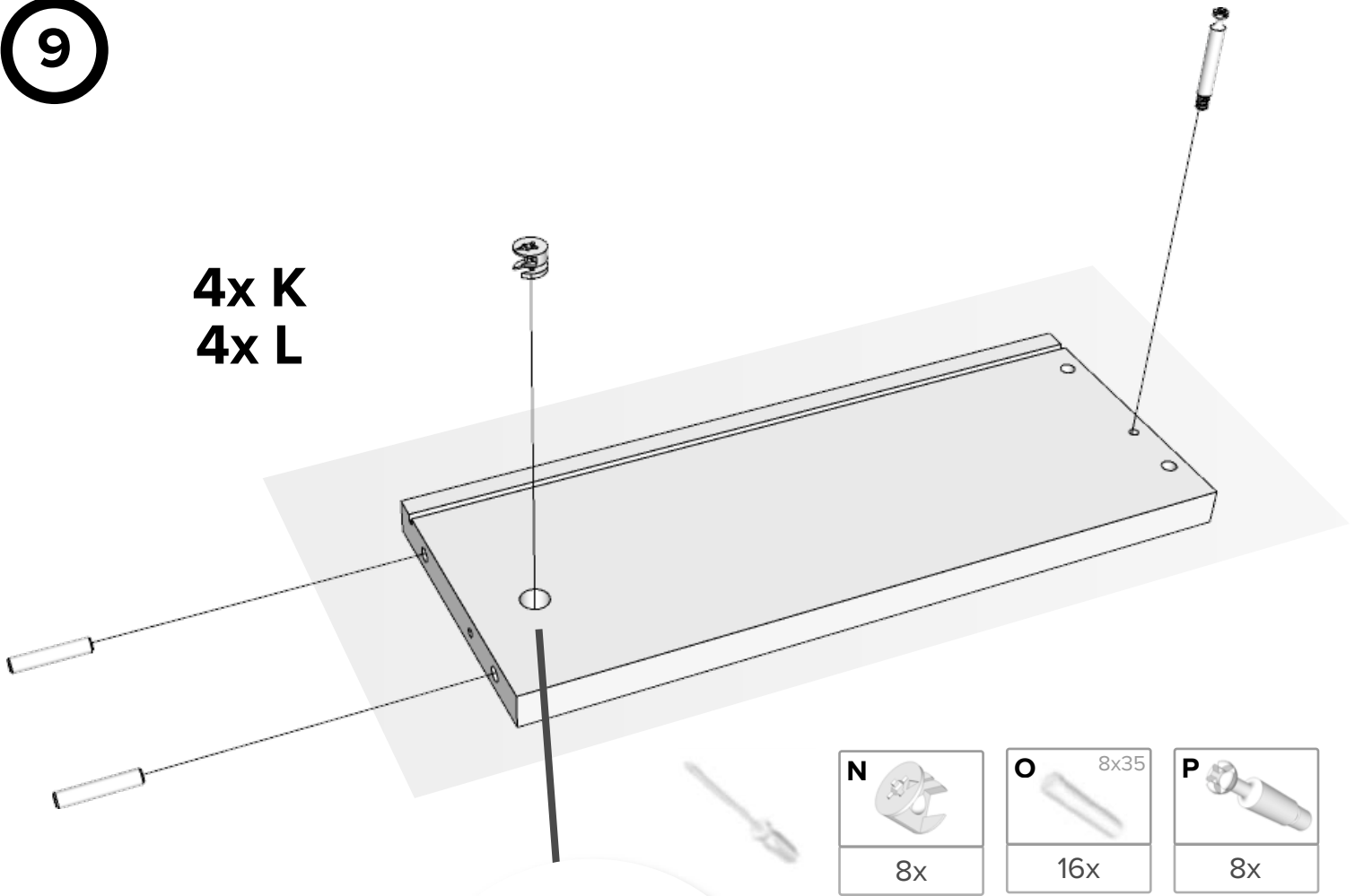

N		O	8x35	P	
	8x		16x		8x

10

4x

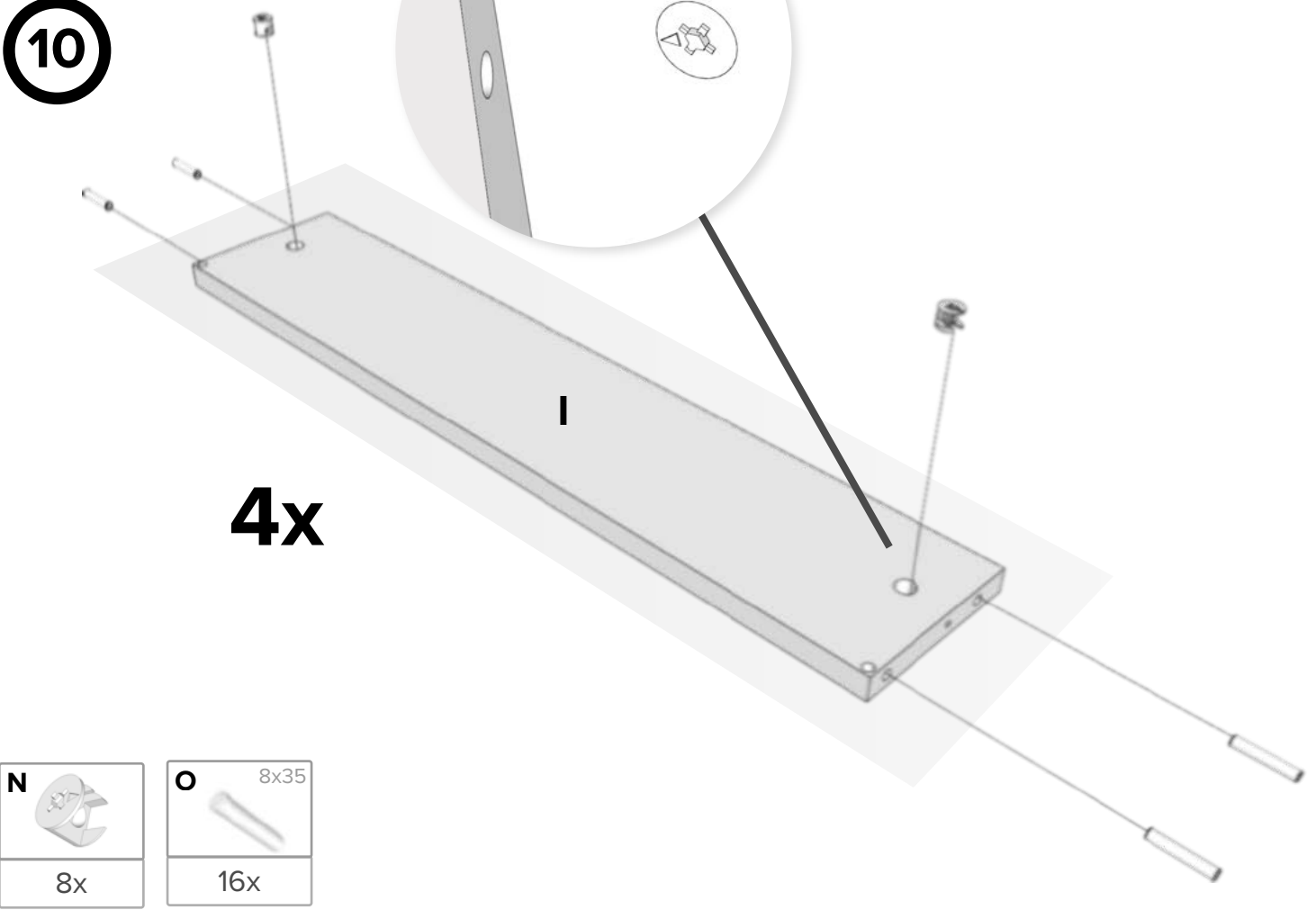

N		O	8x35
	8x		16x

11

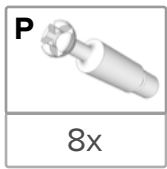
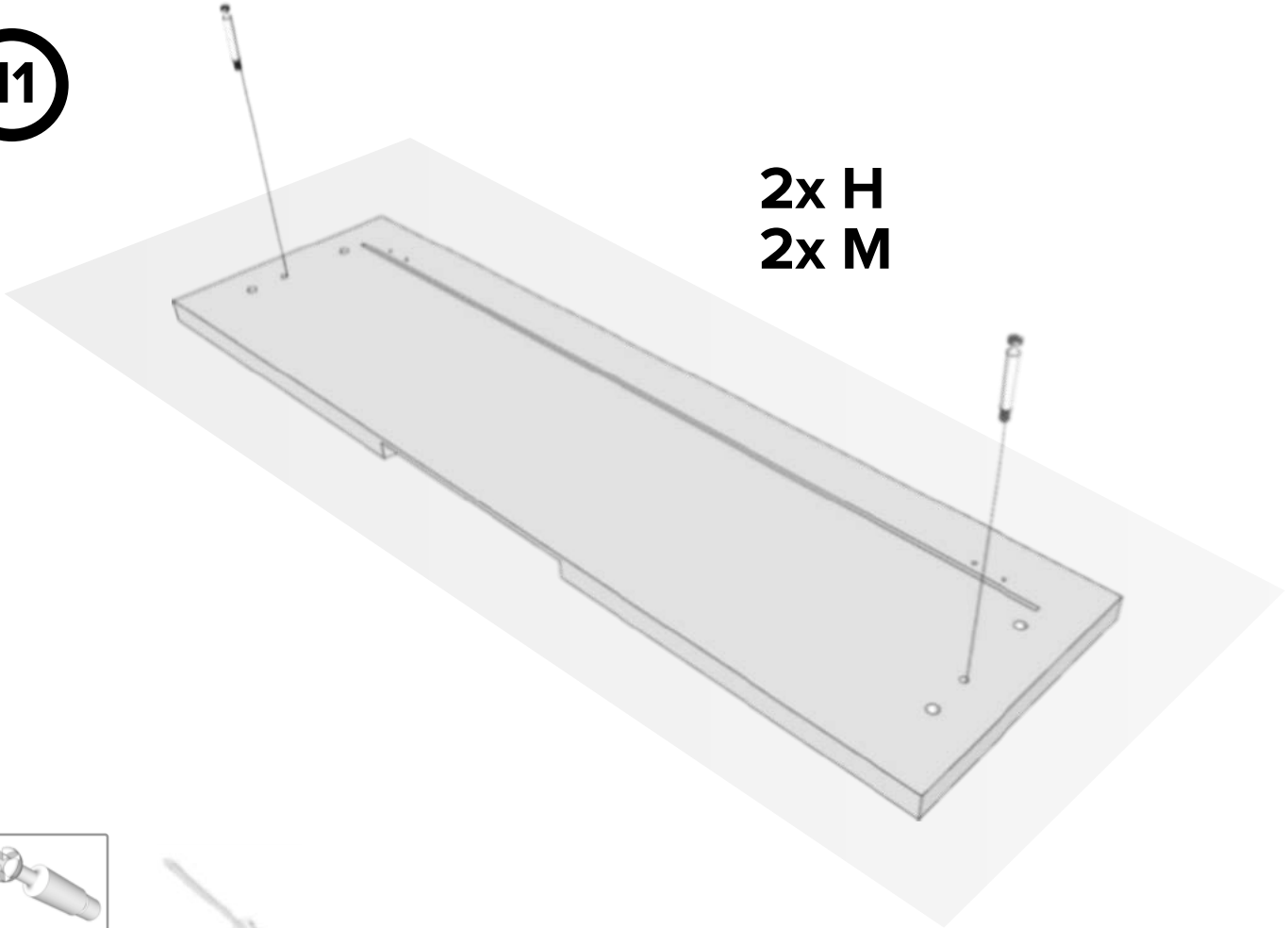

12

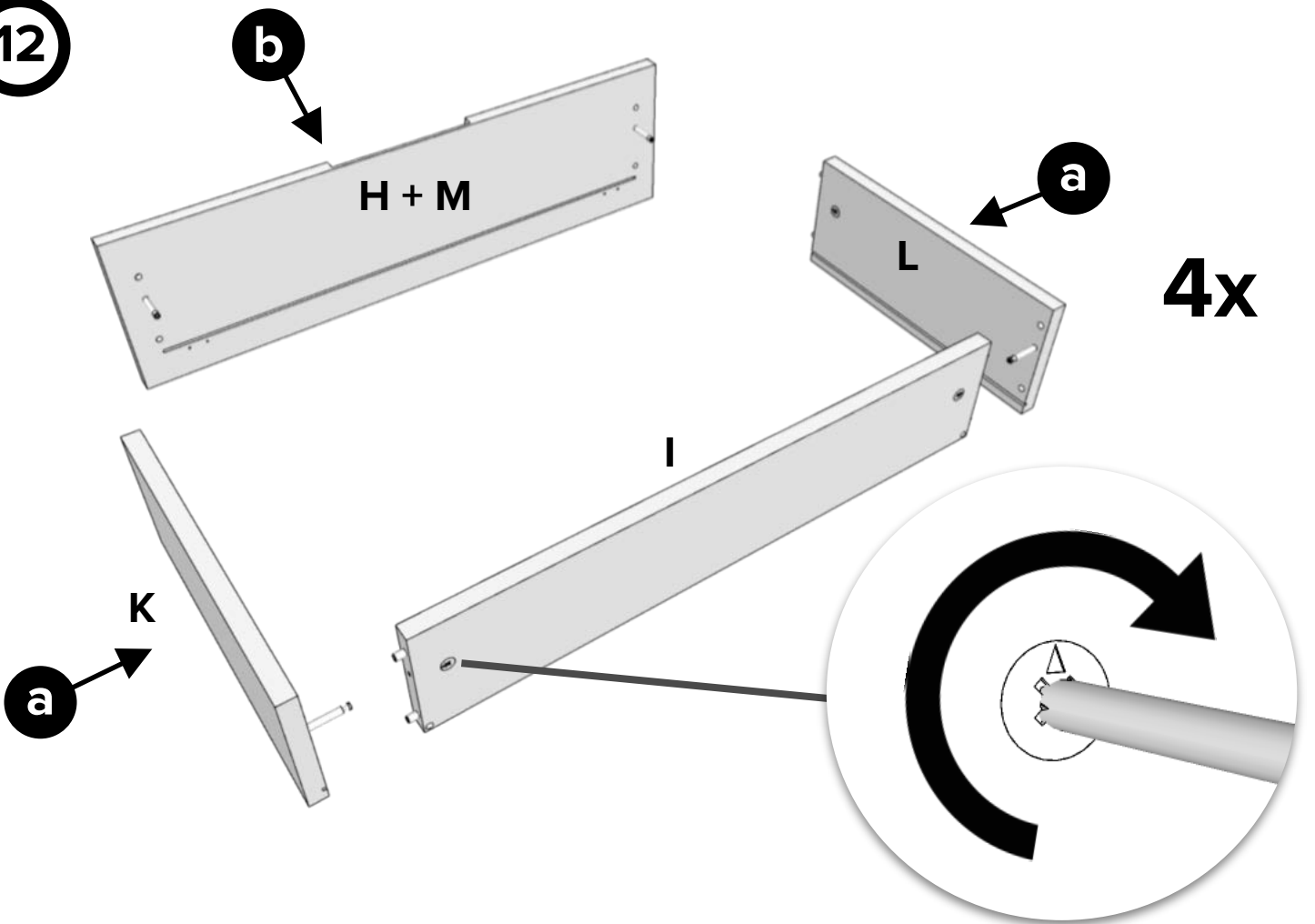

13

4x

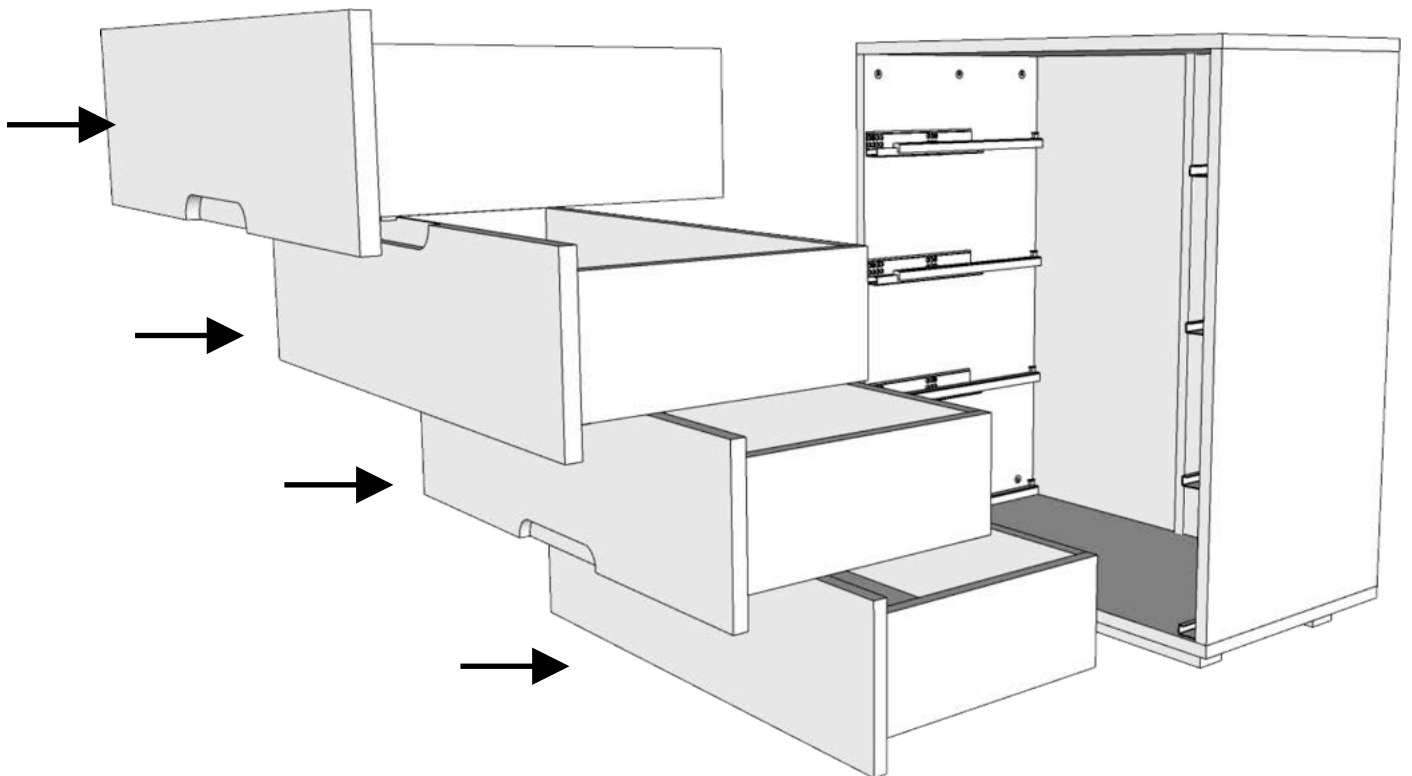
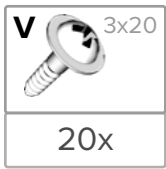
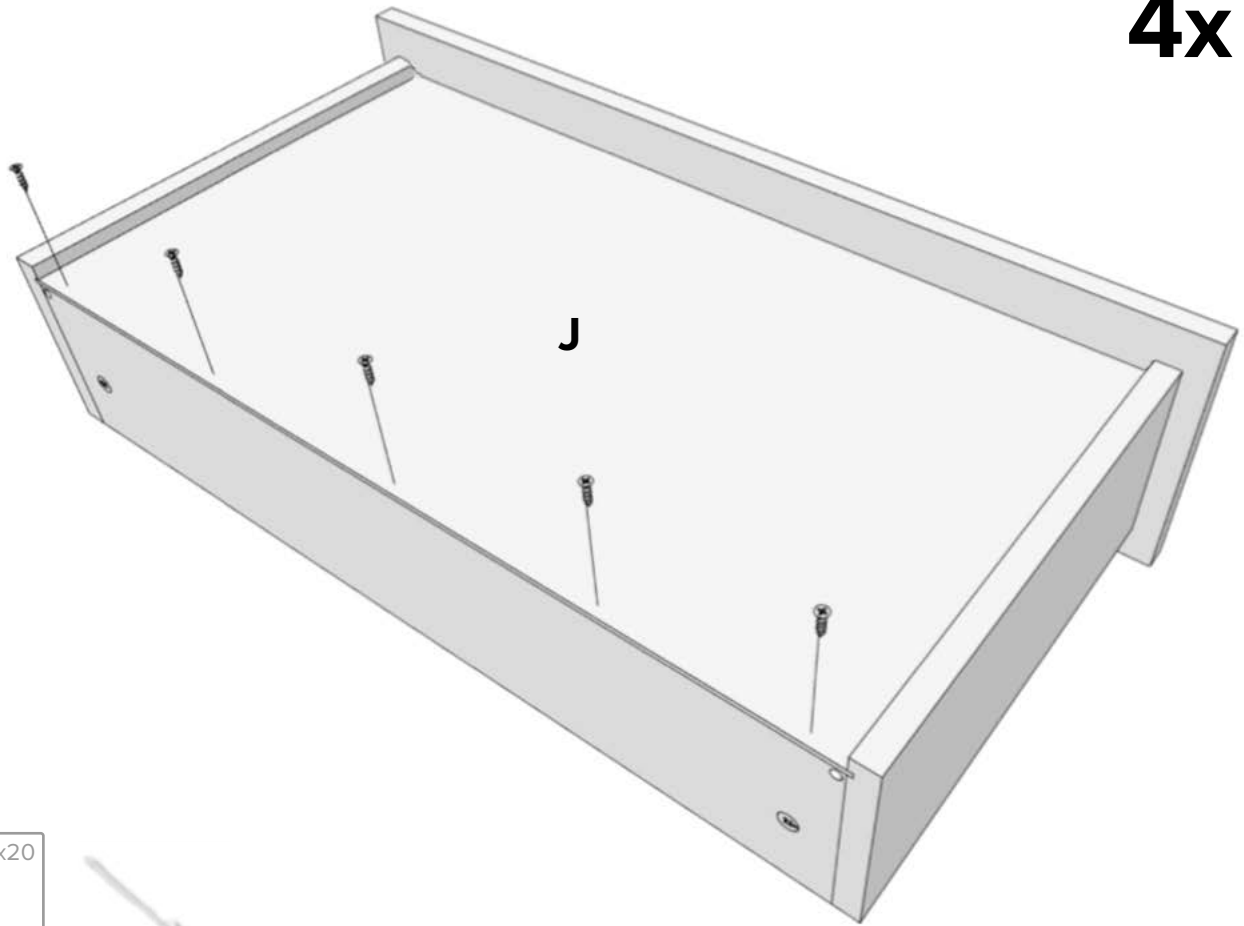

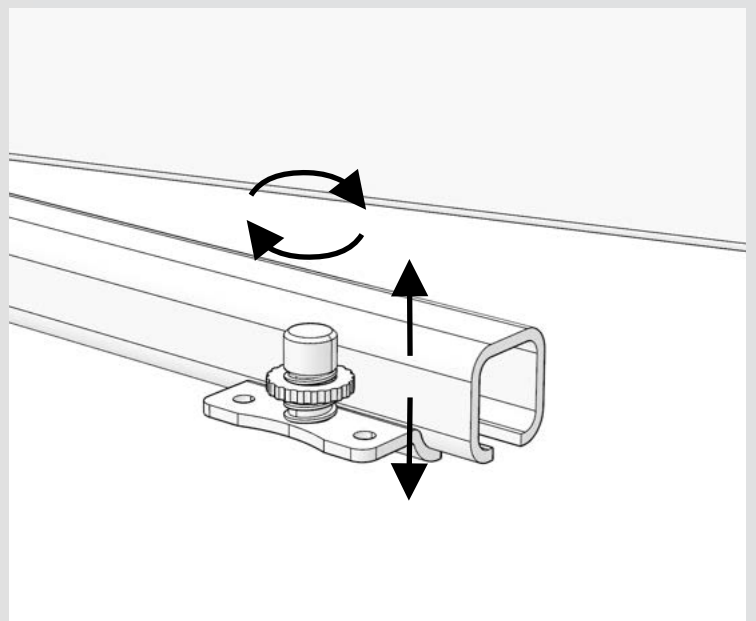
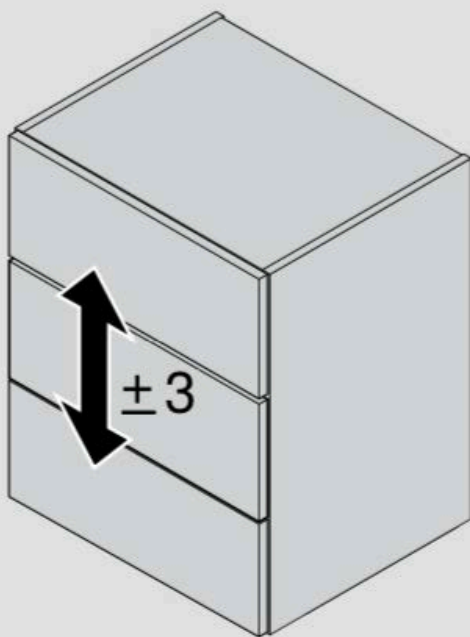
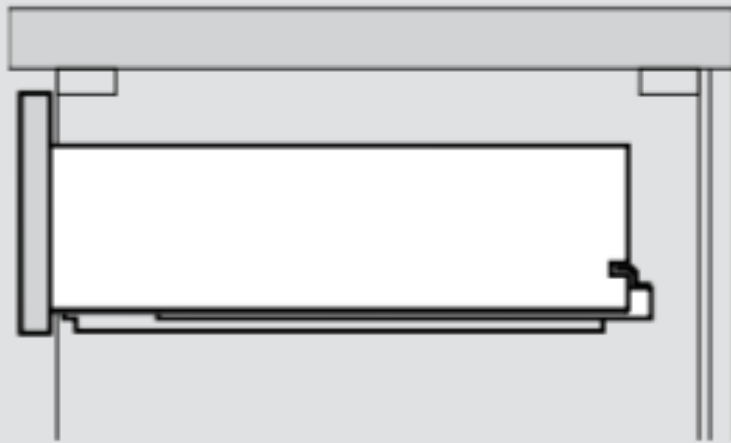
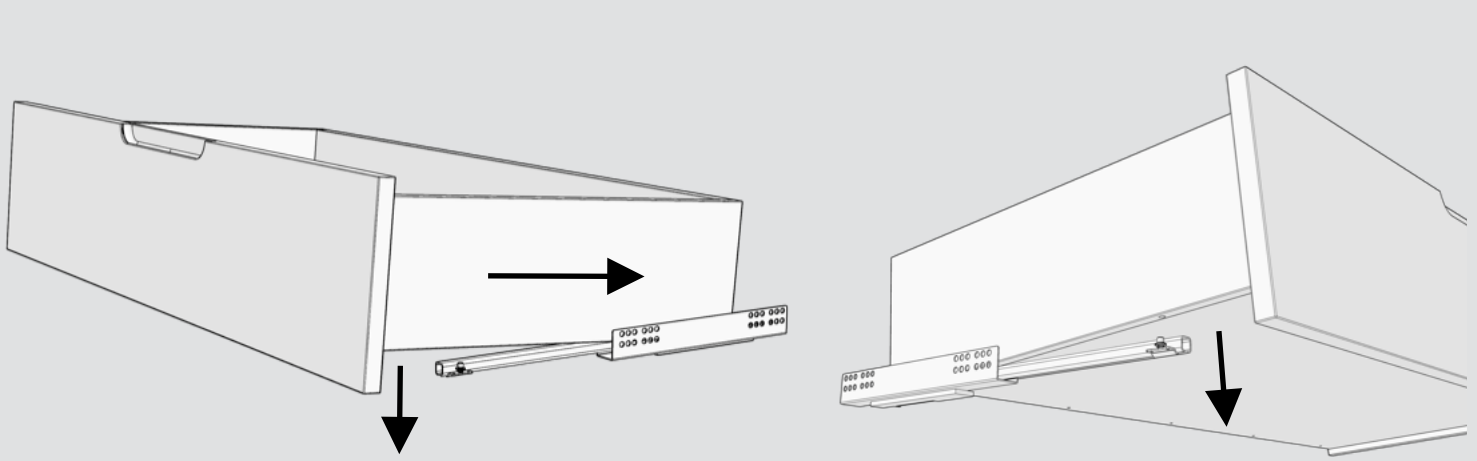

BRAVO!

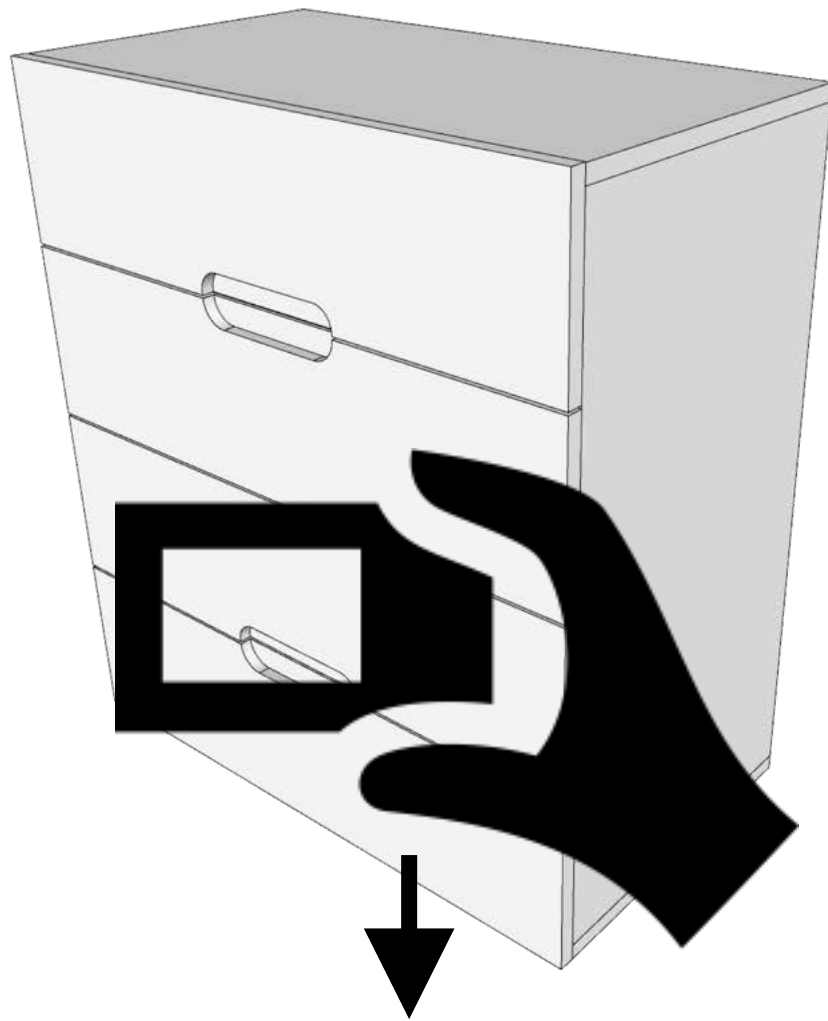

fotos@ekomia.de



☎ +49 (0) 30 41 76 19 72

ekomia.de

✉ service@ekomia.de

