

 ekomia

Vilm

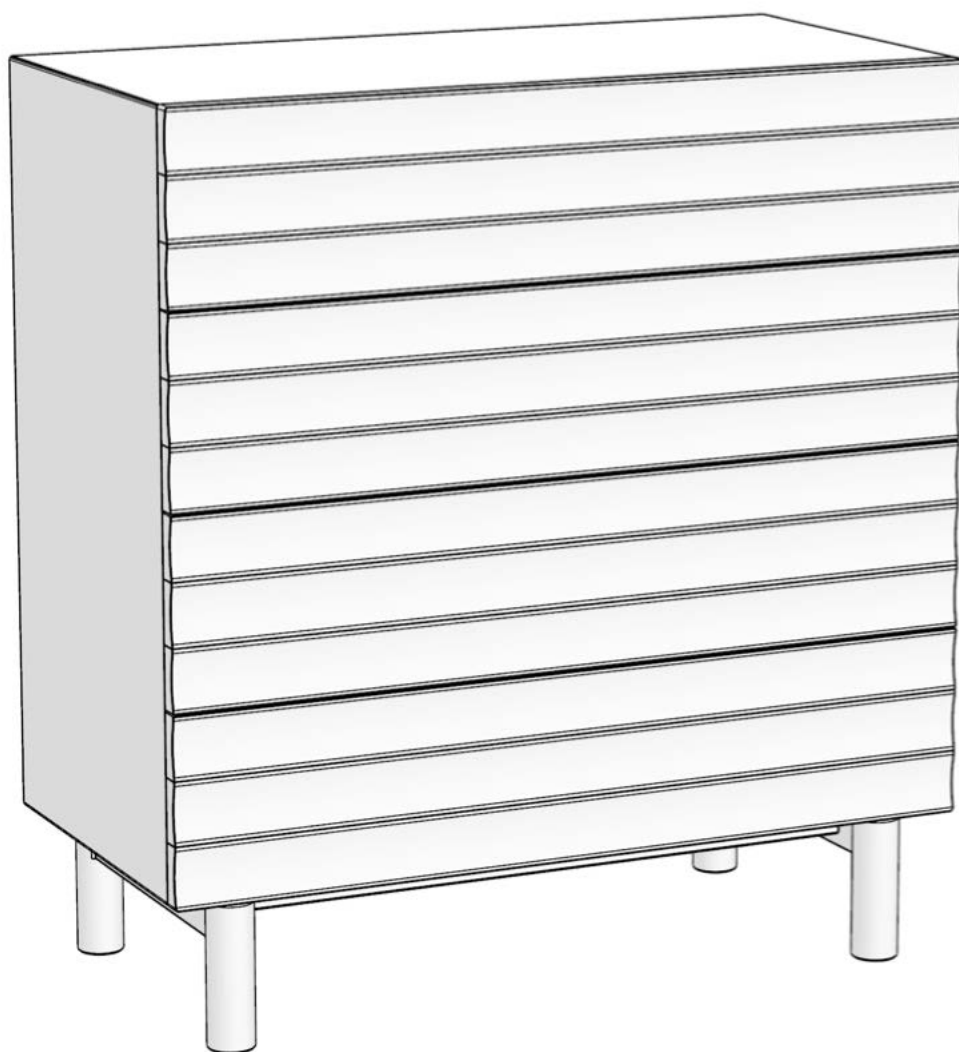

A 1x

B 2x

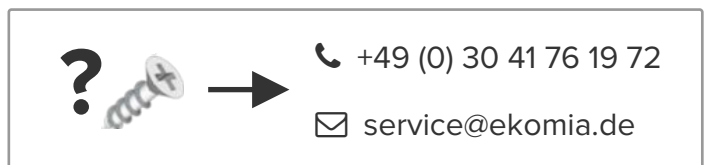
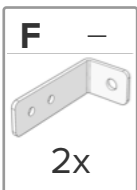
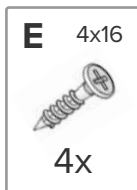
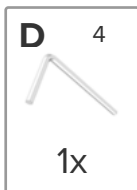
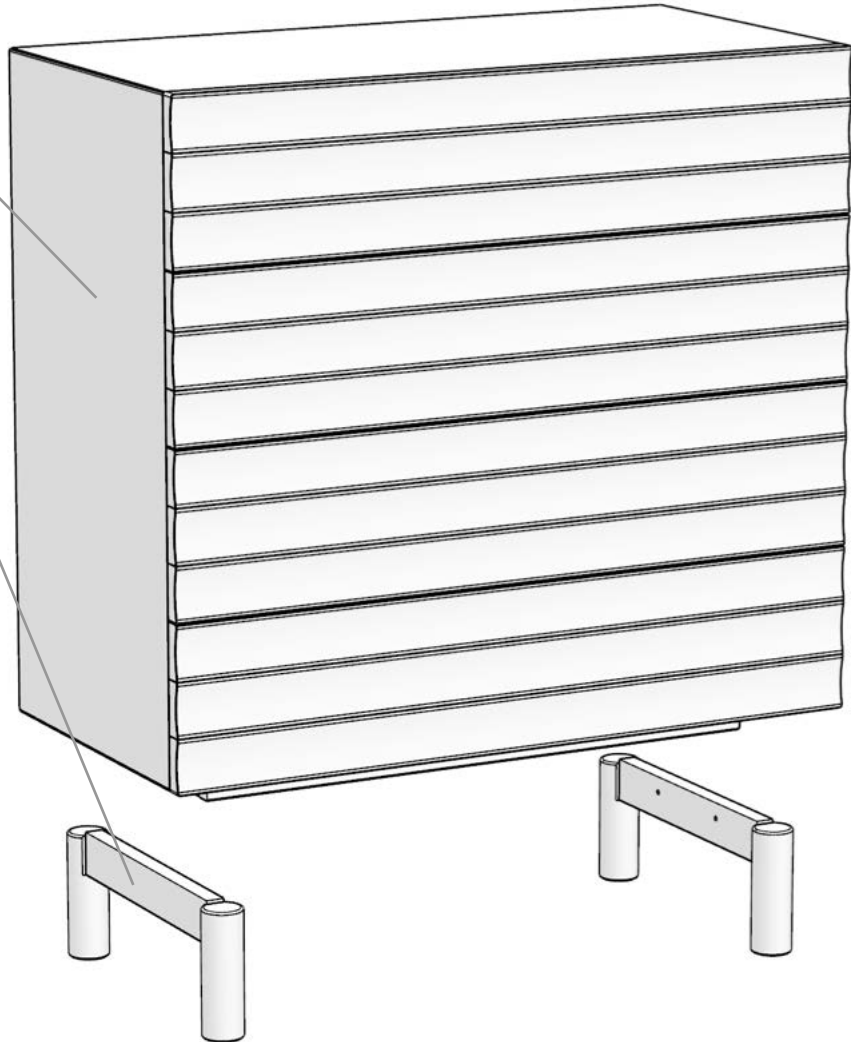

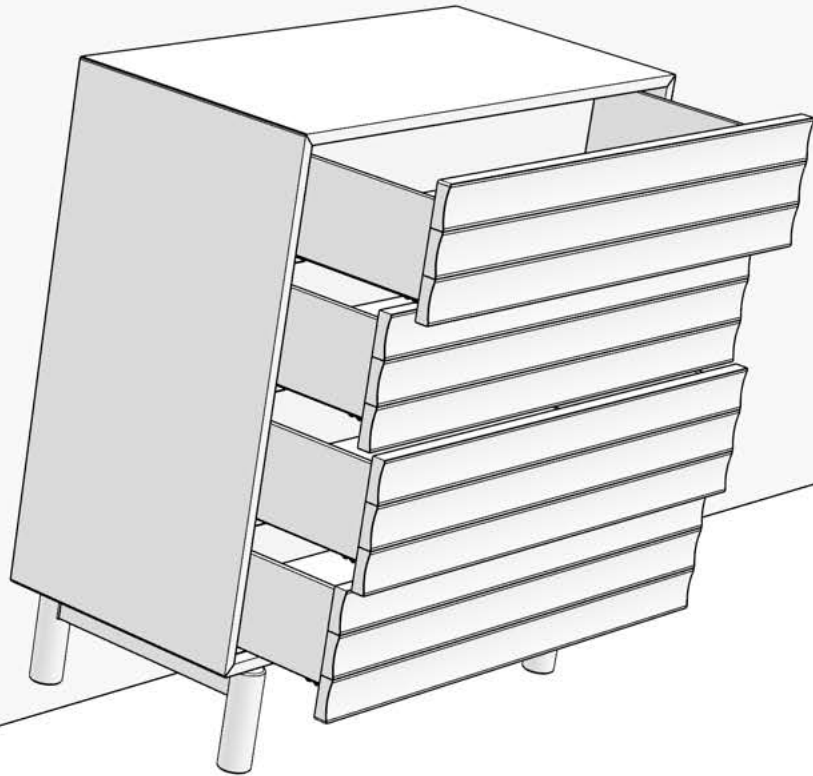

(DE) Achtung! Kippgefahr!

Die Kommode kann umkippen, wenn ein Ungleichgewicht entsteht. Es ist zwingend notwendig, die Kommode an der Wand zu befestigen. Befestigen Sie die Kommode mit den beiliegenden Winkeln und Schrauben sowie mit den für Ihre Wand geeigneten Dübeln und Schrauben an der Wand.

(EN) Attention! Danger of tipping over!

The dresser can tip over if there is an imbalance. It is essential to fix the dresser to the wall. Fix the dresser to the wall with the bracket and screws provided and with appropriate dowels and wall screws for your wall.

(FR) Attention! Danger de basculement!

La commode peut se renverser en cas de déséquilibre. Il est essentiel de fixer la commode au mur. Fixez la commode au mur à l'aide du support et des vis fournis, ainsi qu'avec des chevilles et des vis murales adaptées à votre mur.

(NL) Attentie! Gevaar voor kantelen!

De ladekast kan omvallen als er een onbalans is. Het is essentieel om de commode aan de muur te bevestigen. Bevestig de commode aan de muur met de bijgeleverde beugel en schroeven en met de voor uw muur geschikte pluggen en muurschroeven.

(IT) Attenzione! Pericolo di ribaltamento!

La cassetiera può ribaltarsi se c'è uno squilibrio. È essenziale fissare la cassetiera al muro. Fissare il comò alla parete con la staffa e le viti in dotazione e con i tasselli e le viti da muro adatti alla parete.

(ES) ¡Atención! ¡Peligro de volcar!

La cómoda puede volcarse si hay un desequilibrio. Es imprescindible fijar la cómoda a la pared. Fije la cómoda a la pared con el soporte y los tornillos suministrados y con los tacos y tornillos de pared adecuados para su pared.

1

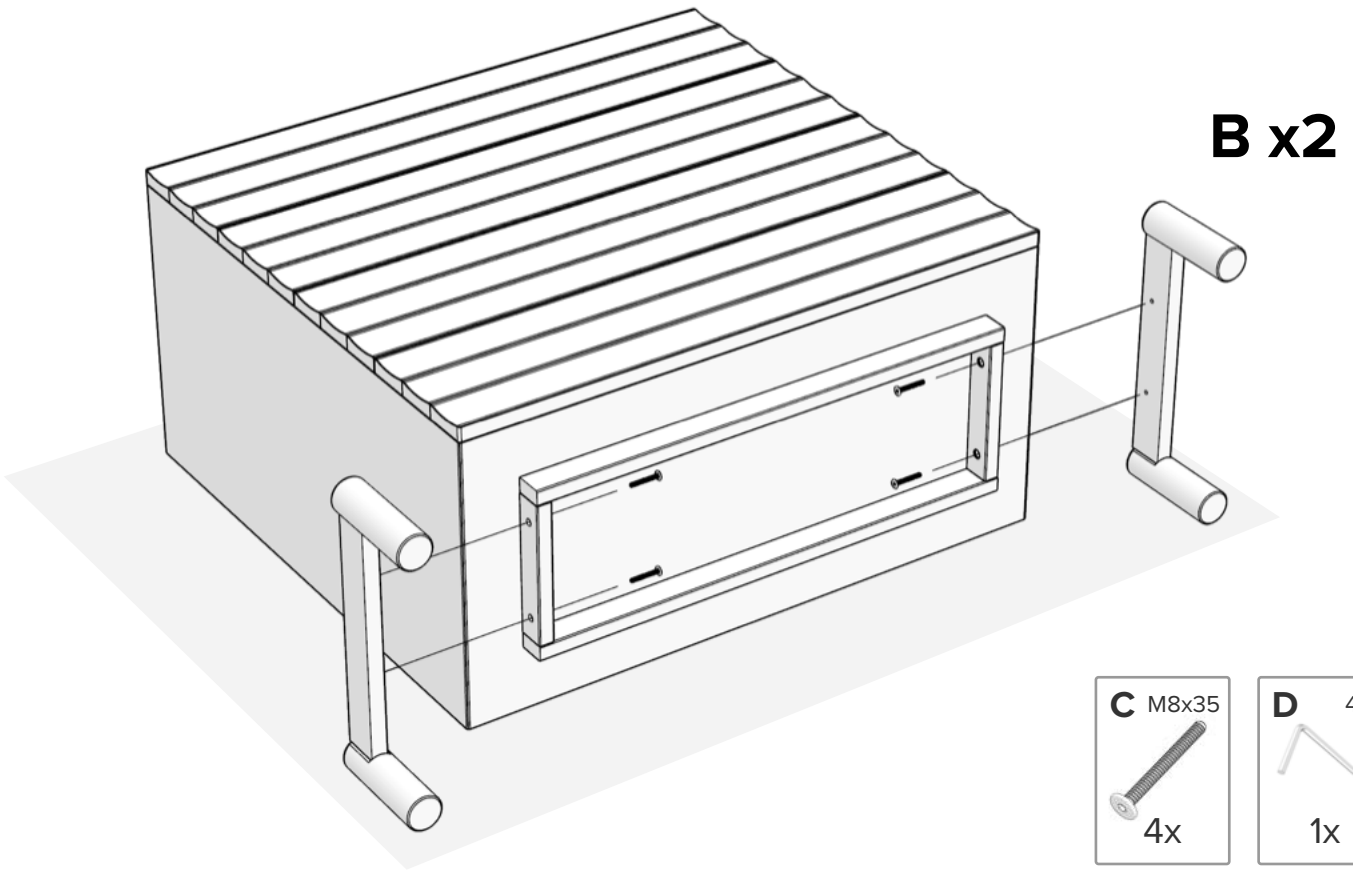

2

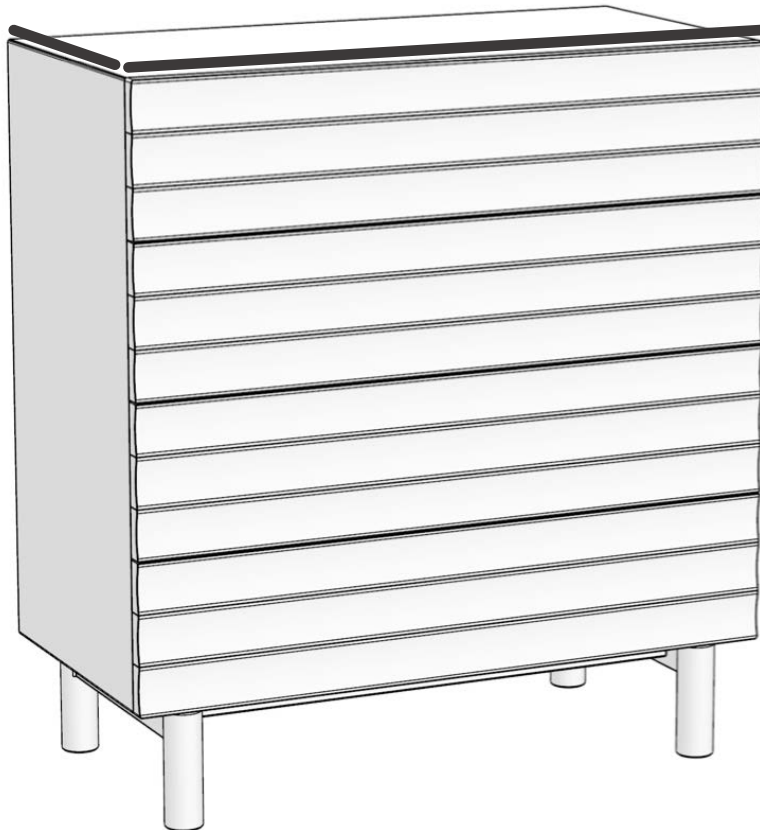

3

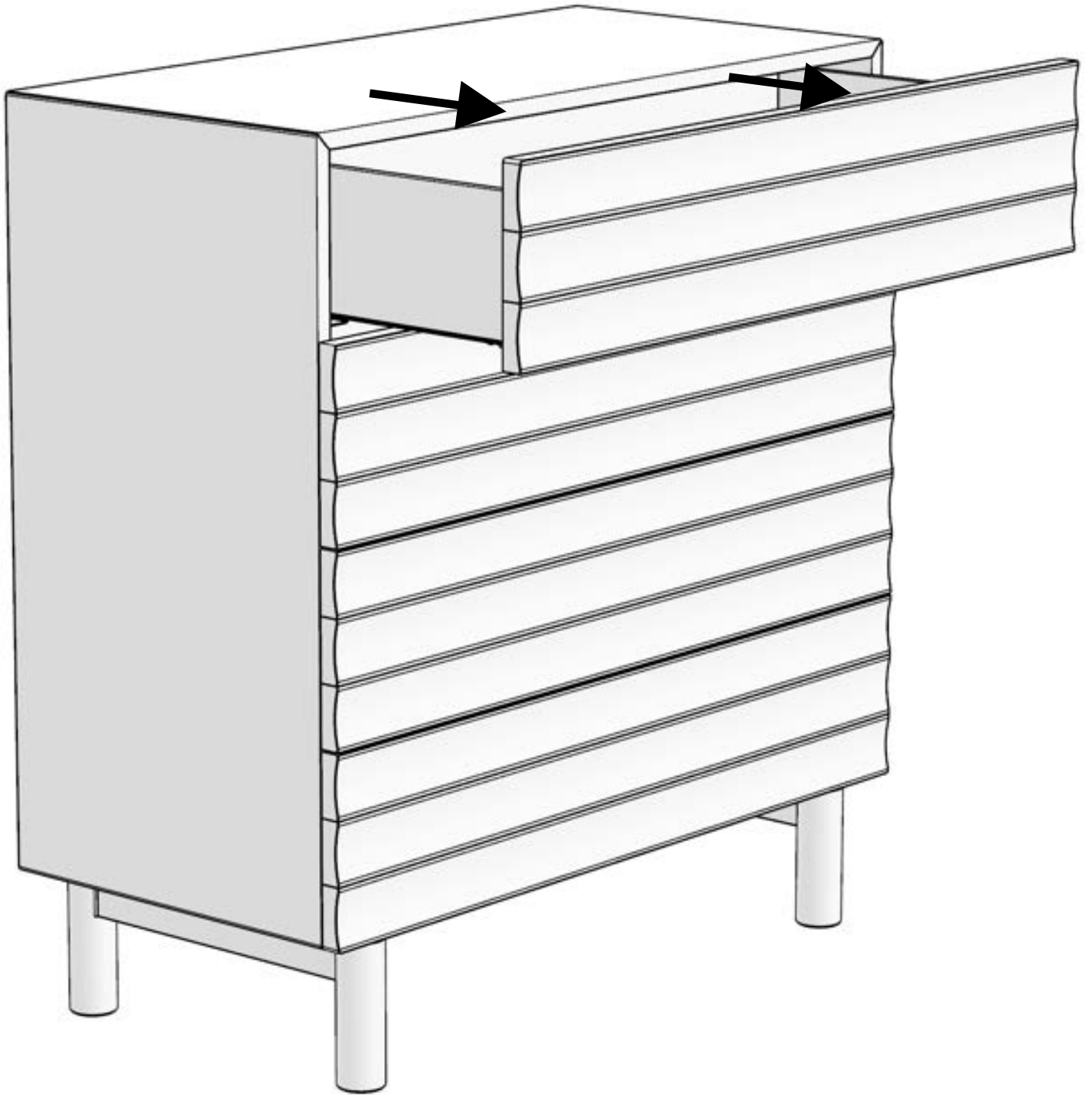

4

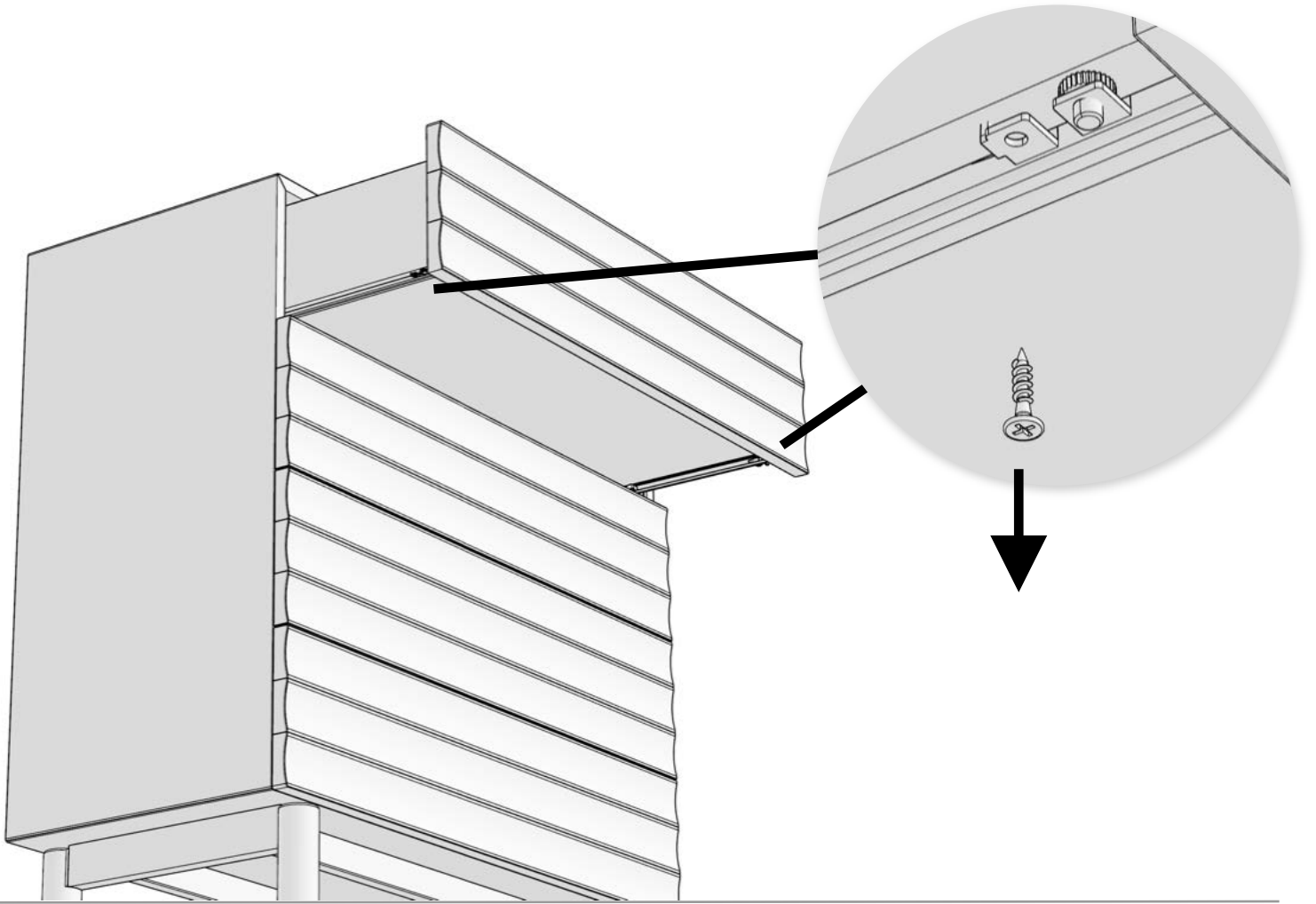

5

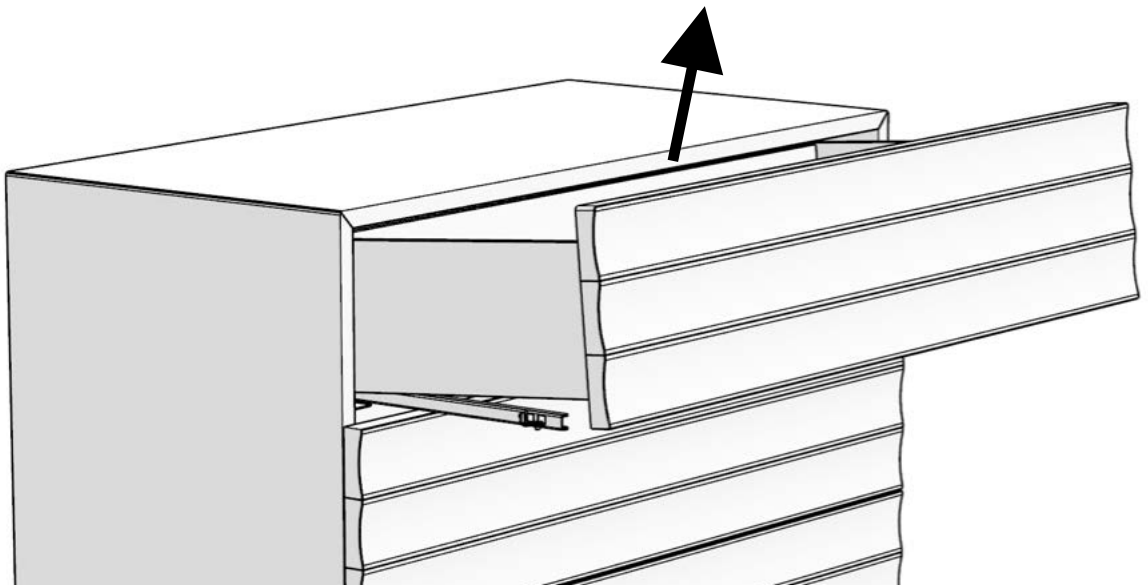

6

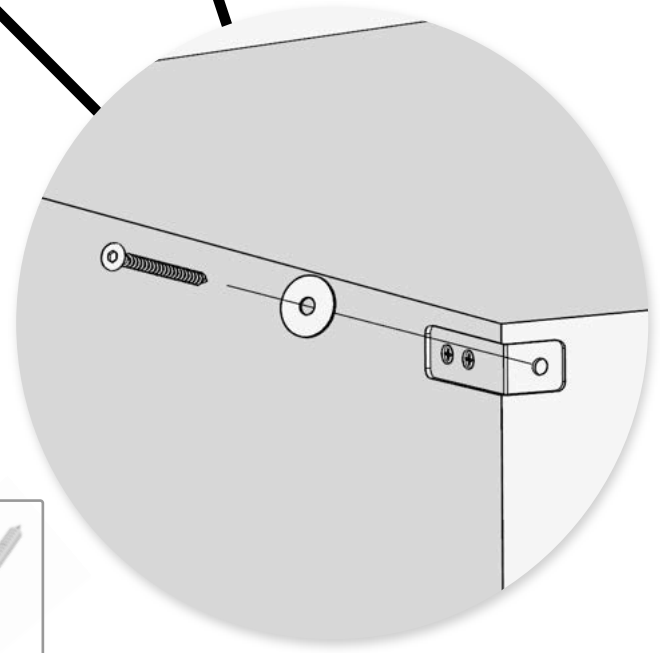
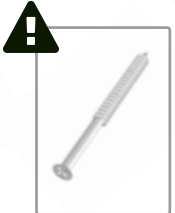
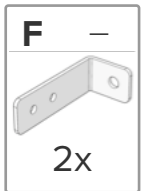
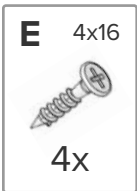
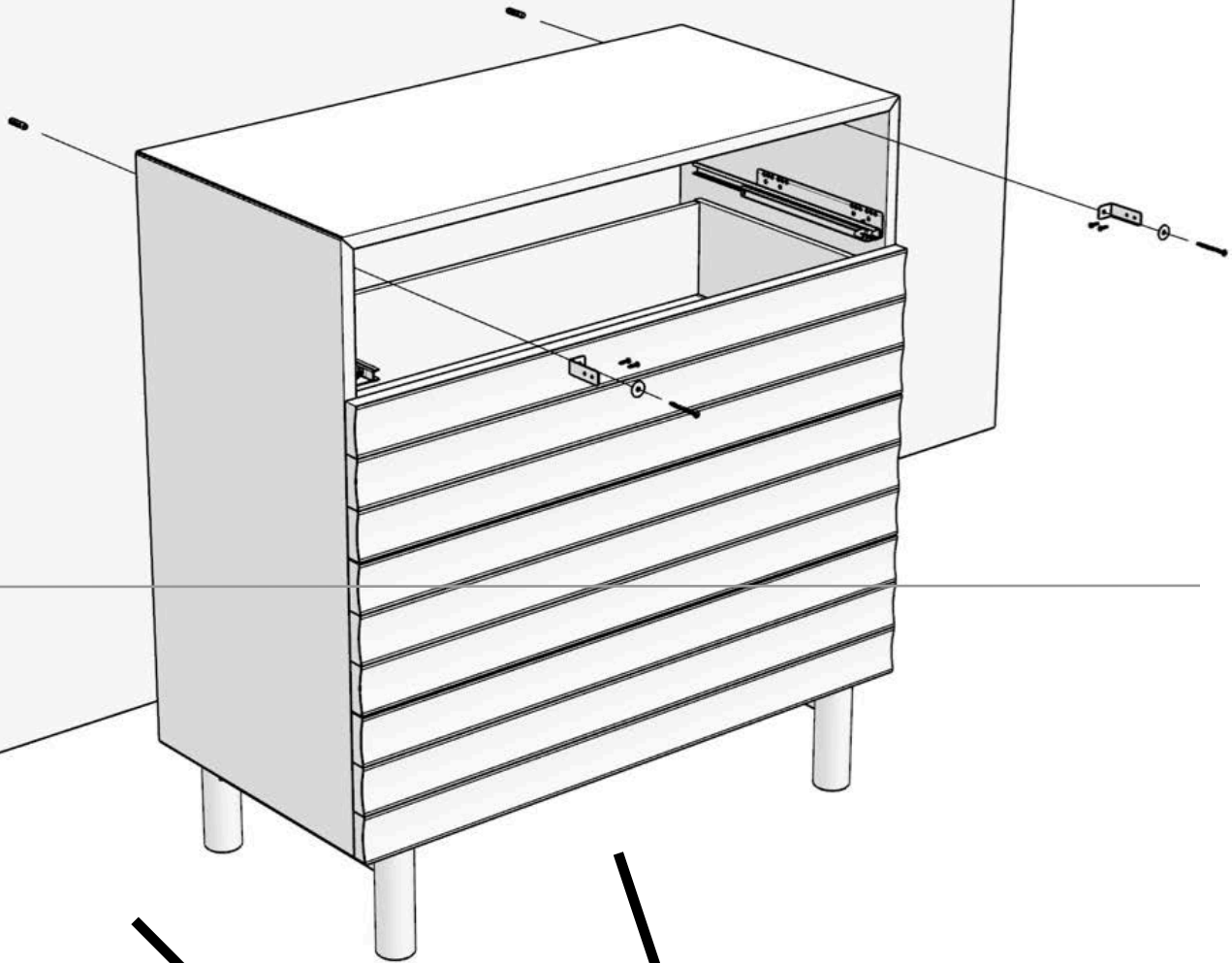

BRAVO!

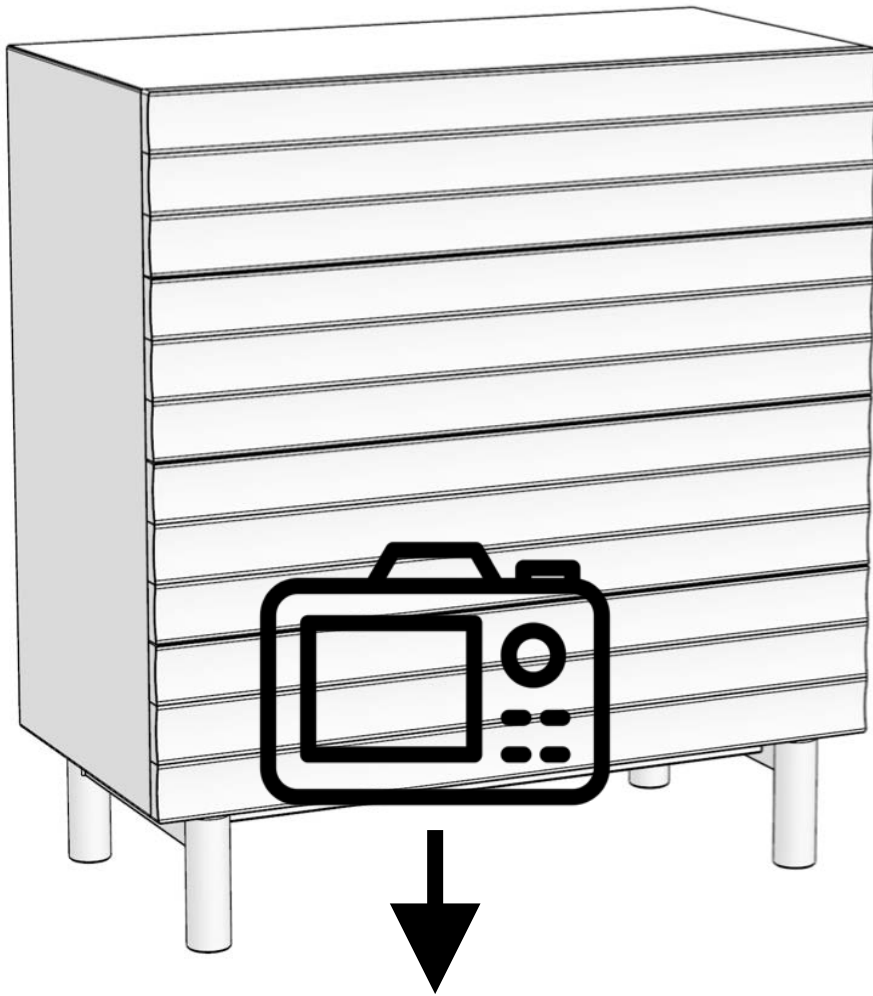

fotos@ekomia.de



☎ +49 (0) 30 41 76 19 72

ekomia.de

✉ service@ekomia.de

