

JAMB ANCHOR

PRODUCT SPECIFICATION

DIMENSIONS:

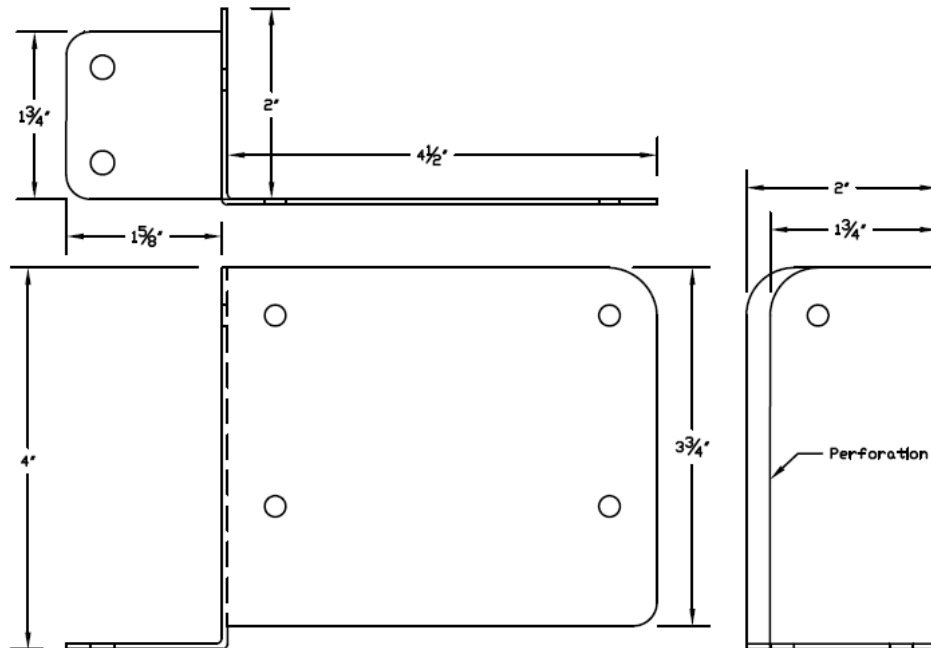

MATERIALS: STEEL W/E-COAT FINISH

THICKNESS: 16GA, 0.056" NOMINAL

THE JAMB ANCHOR IS DESIGNED TO REPAIR THE LOWER PORTION OF AN ALUMINUM DOOR JAMB TUBE. THE DIMENSIONS OF THE ANCHOR COINCIDE WITH 1-3/4"X4-1/2" OR 2"X4-1/2" JAMB TUBE FOUND ON MANY COMMERCIAL ALUMINUM DOOR SYSTEMS.

NOTE: THE EXISTING JAMB DIMENSION SHOULD BE CHECKED AGAINST THIS SPECIFICATION PRIOR TO USING THE JAMB ANCHOR PRODUCT.



Door Innovation, 10503 Citation Dr, Brighton, MI 48116
810-227-7111
www.doorinnovation.com