

Gevi

**2-in-1 Smart
Espresso Coffee Machine**
Brewer | Frother

Gevi



GECME418E-U

**Function Instruction
Quick Use Manual**

Read this booklet thoroughly before using this coffee machine and save it for future reference

Table of Contents

1. Important Safeguards	01
2. Features	05
3. More Details	07
4. Before First Use	09
5. Espresso Making Guide	13
6. Make Milk Foam Guide	29
7. Hot water Guide	40
8. Automatic Sleep Mode Function Guide	41
9. Water Shortage Mode Function Guide	42
10. Care & Cleaning	43
11. Descaling: Group Head & Steam Wand	46
12. Troubleshooting Guide - Espresso Machine	51
13. Troubleshooting Guide - Steam Wand	57
14. Warranty	60
15. Coffees To Try	62

1. Important Safeguards

When using electrical machines, basic safety precautions should always be followed to reduce the risk of fire, electric shock, and/or injury to persons including the following:

1. Read all instructions before using this appliance.
2. Do not touch hot surfaces. Use handles or knobs.
3. Do not leave the machine unattended when in use.
4. Never use the espresso machine without water in the water tank.
5. To protect against electric shock, do not place or immerse cord, plugs, or machine in water or other liquid.
6. Before using, check the output voltage of the wall outlet should correspond to the rated voltage marked on the machine's rating plate.
7. This machine is not intended for use by children or by persons with reduced physical, sensory, or mental capabilities, or lack of experience and knowledge. Close supervision is necessary when any machine is used near children. Children should be supervised to ensure that they do not play with the machine. Keep the machine and its cord out of reach of children.
8. Unplug from outlet when either the machine or display clock (if provided) is not in use, and before cleaning. Allow to cool before putting on or taking off parts, and before cleaning the machine.
9. Do not operate any machine with a damaged cord or plug or after the machine malfunctions, or has been damaged in any manner. Do not attempt to replace or splice a damaged cord. Return machine to an Authorized Service Center for examination, repair or adjustment.

1. Important Safeguards

10. The use of an accessory not recommended by the machine manufacturer for use with this machine may result in fire, electric shock or injury to persons.
11. Do not use outdoors or for commercial purposes.
12. Do not let cord hang over edge of table or counter, or touch hot surfaces.
13. Do not place on or near a hot gas or electric burner, or in a heated oven.
14. Be careful not to get burned by the steam.
15. Do not touch the hot surface of the steam wand and filter holder when boiling directly. Use handle or knobs.
16. Relieve pressure through steam wand before removing portafilter.
17. Always attach plug to machine first, then plug cord into the wall outlet (for machines with detachable cords). To disconnect, turn any control to the off position, then remove plug from wall outlet.
18. To eliminate a choking hazard for young children, remove and safely discard the protective cover fitted to the power plug of the espresso machine.
19. Do not use machine for other than intended use. Misuse can cause injuries.

⚠ WARNING

Always properly engage the Group Head to the locking mechanism. Failure to do so may disengage the Group Head during the brew cycle and cause injuries.

20. Never remove the portafilter during the brewing operation as the machine is under pressure.

1. Important Safeguards

21. Models intended to be used with sealed capsules: Only use capsules intended for this machine. If the capsule does not fit, do not force the capsule into the machine.
22. Models with coffee grinders: Check hopper for presence of foreign objects before using.
23. Household Use Only.

For machines with service panels:

⚠ WARNING

TO REDUCE THE RISK OF FIRE OR ELECTRIC SHOCK, DO NOT REMOVE THIS COVER. NO USER-SERVICEABLE PARTS INSIDE. REPAIR SHOULD BE DONE BY AUTHORIZED SERVICE PERSONNEL ONLY.

⚠ NOTE

SAVE THESE INSTRUCTIONS

For electronic instruction manual, please contact Gevi support team.

North American models with grounded plugs:



POLARIZED PLUG

This machine has a polarized plug, (one blade is wider than the other). As a safety feature to reduce the risk of electrical shock, this plug is intended to fit in a polarized outlet only one way. If the plug does not fit fully in the outlet, reverse the plug. If it still does not fit, contact a qualified electrician. Do not attempt to defeat this safety feature or modify the plug in any way. If the plug fits loosely into the AC outlet or if the AC outlet feels warm do not use that outlet.

1. Important Safeguards

POWER CORD INSTRUCTIONS:

A short power-supply cord (or detachable power-supply cord) may be provided to reduce risks resulting from becoming entangled in or tripping over a longer cord. Longer detachable power-supply cords or extension cords are available and may be used if care is exercised in their use. If a long detachable power-supply cord or extension cord is used:

- a. The marked electrical rating of the detachable power-supply cord or extension cord should be at least as great as the electrical rating of the machine;
- b. If the machine is of the grounded type, the extension cord should be a grounding type 3-wire cord;
- c. The longer cord should be arranged so that it will not drape over the counter top or table top where it can be pulled on by children or tripped over unintentionally.

Do not pull, twist or otherwise abuse the power cord.

PRODUCT NOTICES

1. Place the machine on a hard, flat, level surface to avoid interruption of airflow underneath the espresso maker.
2. Do not operate the machine with an empty water tank.
3. Keep the area above the machine clear during use, as hot steam will escape from the machine.

2. Features

Electrical parameters: 120V~ 60Hz 1350W

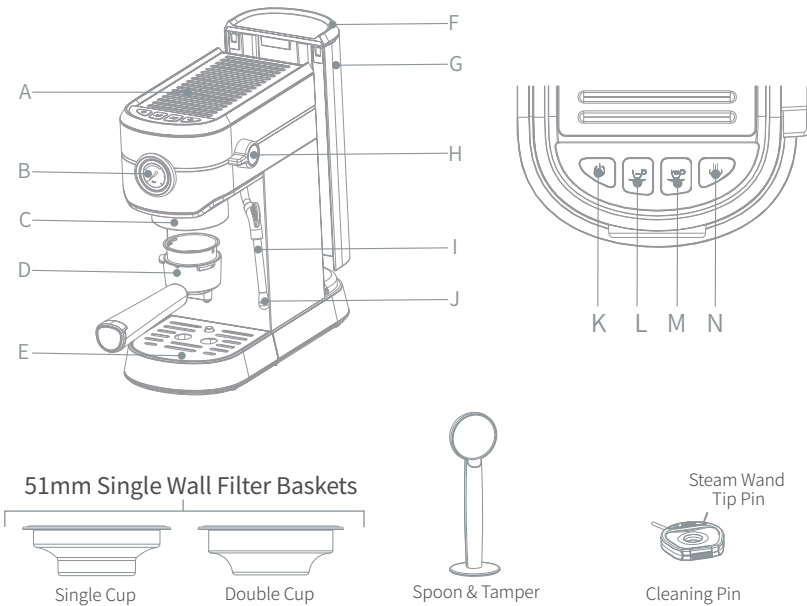

A. Cup warming plate

Preheat cups and glasses which helps retain the essential characteristics of true espresso; aroma and a rich, sweet taste.

B. Pressure Gauge

It helps to improve espresso extraction, to achieve great tasting coffee, every time.

C. Group Head

For easy positioning of the portafilter.

D. Portafilter

The size for a more even water flow & improved extraction taste.

E. Removable Drip Tray

Includes a Water Level Indicator which floats through the Grill indicating when the tray is full and requires emptying.

F. Tank Handle

Lifting upwards using the Handle located inside when remove the Water tank.

2. Features

G. Removable Water Tank

Push back the tank cover & fill with cold water, or remove the Water tank by opening the cover.

H. Steam/water Knob

Turn ☕/🔥 to select steam and hot water.

I. Steam Wand

Ball joint movement with silicone cover, allows movement of the Steam Wand to desired position without burning fingers.

J. Froth Nozzle

Heat insulation and convenient to rotation.

K. ON/OFF Button

The ON/OFF LIGHT will illuminate & pulse to indicate it is warming up. The ON/OFF LIGHT stays fully illuminated when ready.

L. Single/short cup Button

- Pours 1 shot of espresso then automatically stops.
- Customize espresso by setting range 25—60mL.

M. Double/long cup Button

- Pours 2 shot of espresso then automatically stops.
- Customize espresso by setting range 50-130mL.

N. Steam Button

Flashes when ready to steam. Fully illuminated when warming up to steam temperature.

3. More Details

Thermoblock Fast Heating System



- The thermoblock ensures **quick heat up**, and a precise water temperature for the best coffee extraction, and milk frothing.
- The thermoblock is fitted with a **PID controller** which continually monitors the water temperature to ensure water is always delivered to the coffee grinds at the precise temperature needed.
- An espresso is made with hot rather than boiling water. The thermoblock heats the water so that the **espresso extracts at 198°F** (just below boiling point) for optimum extraction of oils from the coffee grinds. Temperatures above this will burn the grinds resulting in a bitter taste.

20 BAR Pump

- The thermoblock works in conjunction with the pump to deliver the correct water temperature at the **correct pressure** for complete extraction of oils, coffee solids and aroma.

Pre-Infusion

- Small amounts of water are released onto the tamped coffee grinds prior to the steady flow of water, for a richer flavored espresso.

Auto Shot Volumetric Control



- Auto Shot is the easiest way to create a great espresso. Just Press the Single /short cup button or Double/ long cup button to pour right amount, then automatically stops.
- All Extraction Buttons can be customised to deliver the shot volumes preferred.

Espresso Pressure Gauge

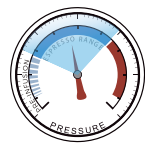

- Monitors espresso extraction pressure and allows you to make espresso to better suit your taste.

3. More Details

Crema System

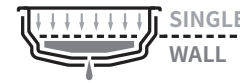

- Grinding fresh whole coffee beans by use Single Wall filter baskets.
- Single Wall filter baskets allow you to experiment with grind, dose and tamp to create a more balanced espresso.

Professional Style Steam Wand



- Stainless steel 360° swivel-action Steam wand for effortless milk frothing.

INSTANT HOT WATER

- Use for long black coffee, hot drinks such as tea, instant soups and to warm cups prior to making espresso.

Cafe51mm Group Head & Portafilter

- The 51mm Portafilter holds more coffee grinds, resulting in a true café tasting coffee. The wider size ensures the grinds are more evenly spread and easier to fill, for improved flavor extraction.
- The 51mm Filter Baskets allow a more consistent grind compaction, resulting in a better tasting coffee, and an easier to empty used espresso pucks.

4. Before First Use

4.1 Remove Packaging

Ensure all packaging has been removed.

⚠ IMPORTANT

Remove the silicone cap found at the base of the Water Tank.

4.2 Position Machine

Ensure the espresso machine is always positioned onto a dry, stable, flat horizontal counter top.

4.3 Wash & Dry Parts

Wash the parts listed below in warm water:

- Single Cup Filter Baskets.
- Double Cup Filter Baskets.
- Portafilter.
- Spoon & Tamper.
- Removable Water Tank.

⚠ IMPORTANT

Below this part is NOT-DISHWASHER SAFE:

- Portafilter.
- Drip Tray.
- Water Tank.

Rinse and dry each part thoroughly then place on the machine.

4.4 Preparing to Prime Machine

⚠ IMPORTANT

This priming step must be completed prior to first use.

• Fill Water Tank

Step 1 - Make sure to tear off the silicone cap from the bottom of the water tank.

Step 2 - Extract the tank by pulling it upwards.

Step 3 - Open the lid and fill the tank with fresh clean water, taking care not to exceed the MAX level.

Step 4 - Use a clean cloth to wipe off the water on the valves. Put the tank back in the machine, pressing lightly to open the valves located on the bottom of the tank.

Step 5 - Set up the water tank vertically and align the buckles to the hole on the back of the machine, and press it down to be parallel to the top of the machine.

⚠ NOTE

More simply, the tank can also be filled without extracting it by pouring the water directly from a jug.

4. Before First Use

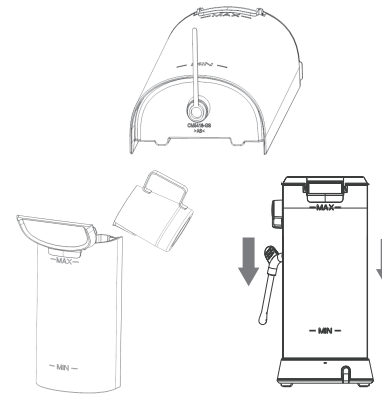

⚠ NOTE

Make sure that the Water Tank is clean & free of any debris, as any fine particles can block the water flow.

• Power

Ensure that:

Step 1 - The steam/water knob is in a horizontal position (off-position).

Step 2 - Insert the Power Plug into a 120V AC power outlet & switch the power on.

Step 3 - Press the ON/OFF button to turn on the machine.

- The ON/OFF button will illuminate & pulse to indicate the Thermoblock is heating up.

- When 4 button's Light are all fully illuminated, the machine is in the READY state for all features.

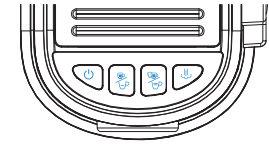

• Insert Portafilter

Step 1 - Place the Double-cup Filter Basket in the Portafilter.

Step 2 - Insert the Portafilter into the Group Head.

Step 3 - To ensure that the Portafilter is in the correct position, align the Portafilter with the 'INSERT' position located on the left of the Group Head.

Step 4 - Insert the Portafilter flat against the Group Head, then turn the Portafilter right all the way to the center position.

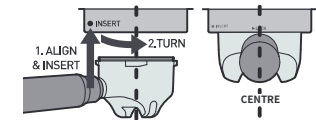

⚠ NOTE

Turning the Portafilter to the centre position might be tight for the first few uses.

4.5 Prime Espresso Machine

Step 1 - Position Steam Wand over the Drip Tray. Or place a container with a minimum capacity of 100 mL under the hot water/steam spout.

4. Before First Use

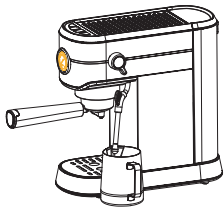

- Step 2 - Turn knob to “☕/💧”.
- Allow water to run through for 20 sec.
- Step 3 - Return knob to horizontal position (off-position).
- The machine will return to the READY state.

⚠ NOTE

For the first few seconds the Pump will make a louder than usual noise as it begins pumping the water through.

⚠ IMPORTANT

- If water is still not running through from Steam Wand. It can be caused by pressurized air in the boiler hindering the flow. And follow the Step 4-10.
- Otherwise, if water to run through for 20 sec from Steam Wand. skip to Step 11 to next operation.

Step 4 - Position Steam Wand over the Drip Tray, or place a container with a minimum capacity of 100mL under the hot water/steam spout.

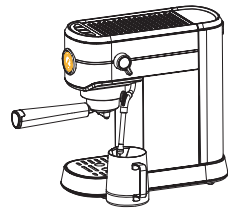

- Step 5 - Turn knob to “☕/💧”.
- Allow water to run through for 3 minutes.
- Step 6 - Return knob to horizontal position (off-position).
- Left the water deposit in machine for 1 day.

⚠ NOTE

the water in the water tank does not need to be poured out.

- Step 7 - After 1 day, Insert the Power Plug into a 120V AC power outlet & switch the power on. The machine switches on automatically.
- Step 8 - Press the ON/OFF button to turn on the machine.
- The ON/OFF button will illuminate & pulse to indicate the Thermoblock is heating up.
 - When 4 button's Light are all fully illuminated, the machine is in the READY state for all features.

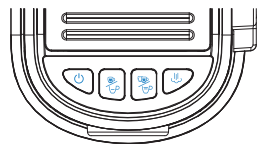

4. Before First Use

Step 9 - Repeat the above "Prime Espresso Machine" step 4-6 at least 3 times to fill the water tank with water.

- Step 10 - Return knob to horizontal position (off-position).
- The machine will return to the READY state.

If water is still not running through, contact Gevi Customer Care.

Step 11 - Put the cup on the Removable Cup Shelf.

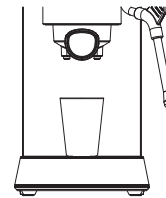

Step 12 - Press the Double/long cup button & water should start flowing from the Group Head.

⚠ NOTE

After making the froth milk, if you want to continue to brew coffee, You will find the high-temperature status by press the single cup button or double cup button, refer to "15. Make Espresso Immediately After Frothing Milk", page 33.

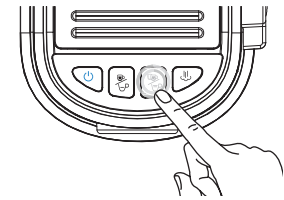

- Allow water to run through until it stops.
 - The machine will return to the READY state.
- Step 13 - Pour away the water in the cup.
- Step 14 - Wash Portafilter & Filter Basket in warm water & dry before making your first coffee.

⚠ NOTE

The machine is not equipped with any jug, please use your jug or coffee cup.



Step 15 - Repeat the above "Prime Espresso Machine" Step 1-3 & Step 11-14 by 2-3 times until it is clean. Now the Espresso Machine should be thoroughly primed.

If water is still not running through, contact Gevi Customer Care.

5. Espresso Making Guide

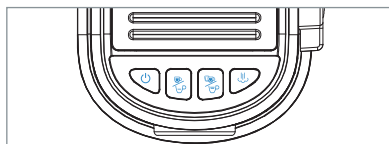
5.1 Brief Introduction



	Single/short cup button. Press Single/short cup button to start then it automatically stops.
	Double/long cup button. Press Double/long cup button to start then it automatically stops.

5.2 Tips for Making the Perfect Cup

1. Extraction Time

Espresso around 30ml/cup.

Extraction time is a good indicator of the quality of the pour. The optimum time per shot varies between types & freshness of coffee beans. However, in general, the pour time should be between 20-30 seconds for both One & Two Cup shots.

2. Type of Extraction

• Optimum Extraction

A quality pour has a steady flow with a consistency similar to that of warm honey. The resulting crema is dark golden. The sweetest flavours & oils

have been extracted creating a rich tasting espresso.

• Under Extraction

The pour is fast & light in colour, the resulting crema is thin with a creamy light brown colour which quickly dissipates. This occurs when too little of the essential oils, flavours & colours from the coffee grinds have been extracted. This creates a sour tasting espresso.

• Over Extraction

There may be no pour, or it may be slow & drip throughout the entire pour. The resulting crema is very dark. This occurs when too much of the essential oils, flavours & colours from the coffee grinds have been extracted. This creates a bitter tasting espresso.

3. Look for Colour Change

The optimum shot contains 3 elements:

Heart: At the base-starts out dark brown.

Body: Blends with the heart-becomes a rich caramel with reddish reflections.

Crema: The layer on top of the body-dark golden.



5. Espresso Making Guide

4.Grinds

You may need to vary the coffee grind size when using different beans.

⚠ IMPORTANT

Ensure beans or pre-ground grinds are fresh. Old pre-ground grinds and old beans, no matter the grind size, will not produce a good tasting espresso

5.Grind Dosage

For best results, grind dosage should remain consistent:

One Cup: 7g - about 1 Tbsp.

Two Cups: 14g - about 2 Tbsp.

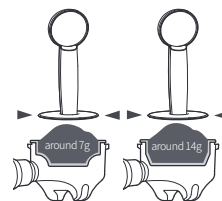

⚠ NOTE

Use the single cup filter basket when brewing a single cup and the double cup filter basket when brewing two cups or a stronger single cup or mug.

⚠ NOTE

When using pre-ground bagged grinds, try using a 2 step dose & tamp method: Dose in half the grinds then tamp & repeat.

⚠ NOTE

A spoon of flat coffee powder is approximately equal to 7g. Collect the coffee powder with the spoon and shake it gently to make the surface flat, the amount of coffee powder is around 7g. One spoon coffee powder (7g) can make one cup of top-grade coffee, while two spoons (14g) is two cups of top-grade coffee.

6.Tamp Force

For best results, evenly tamp (press) grinds to the level indicated.

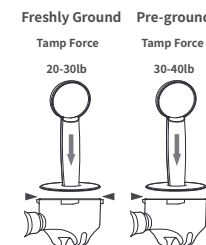

⚠ NOTE

Isolating changes to Grind Size & Tamp Force will assist in producing a consistent taste every time.

⚠ NOTE

Tamp the coffee powder gently below the the MAX line of portafilter. Don't tamped the coffee powder too firmly.

5. Espresso Making Guide

7. Filter Baskets

• Single Wall Filter Baskets

Use Single Wall filter baskets if grinding fresh whole coffee beans.

Single Wall filter baskets allow you to experiment with grind, dose and tamp to create a more balanced espresso.



8. Extraction Guide

There are extraction variations from bean to bean, and everyone's taste is different. Use the below as a guide to improve your espresso technique, so it's just right for you.

5. Espresso Making Guide

CORRECT EXTRACTION

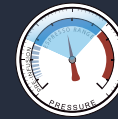

Within Espresso Range

OPTIMUM EXTRACTION

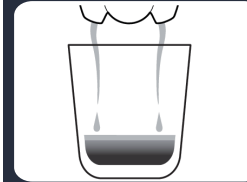

- Flow starts after 4-7 secs
- Flow slow like warm honey
- Crema is golden brown with a fine mousse texture
- Espresso is dark brown
- Extraction takes 25-35 secs

AFTER EXTRACTION



Remove used grinds:
Used grinds will form a coffee 'puck'.



Rinse filter basket
keep the filter basket clean to prevent blockages.



Without ground coffee in the filter basket, lock the Portafilter into the machine and run hot water through.

UNDER EXTRACTION

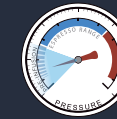

Under Espresso Range

UNDER EXTRACTION

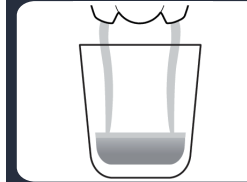

- Flows starts after 3-5 secs
- Flow fast like water
- Crema is thin and pale
- Espresso is pale brown
- Tastes bitter/sharp, weak and watery
- Extraction takes up to 20 secs

SOLUTIONS

Adjust & retest:
Grind size finer
Increase powder amount.

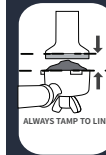

Tamp using too heavy of pressure. The top edge of metal cap on the tamper should be level with the top of the filter basket AFTER tamping.

OVER EXTRACTION

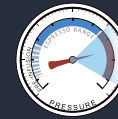

Over Espresso Range

OVER EXTRACTION



- Flow starts after 8 secs
- Flow drips or not at all
- Crema is dark and spotty
- Espresso is very dark brown
- Tastes bitter and burnt
- Extraction takes more than 40 secs

SOLUTIONS

Adjust & retest:
Grind size coarser
Decrease powder amount.

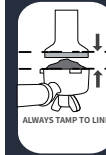

Tamp using too light of pressure. The top edge of metal cap on the tamper should be level with the top of the filter basket AFTER tamping.

5. Espresso Making Guide

	GRIND	GRIND DOSE	TAMP	SHOT TIME
OVER EXTRACTED (BITTER · ASTRINGENT)	TOO FINE	TOO MUCH USE RAZOR TO TRIM	TOO HEAVY	OVER 40 SEC
BALANCED	OPTIMUM	7g- about 1 Tbsp (One Cup) 14g- about 2 Tbsp (Two Cups)	30-40lbs (15-20kg)	15-35 SEC
UNDER EXTRACTED (UNDERDEVELOPED · SOUR)	TOO COARSE	TOO LITTLE (increase dose) INCREASE DOSE & USE RAZOR TO TRIM	TOO LIGHT	UNDER 15 SEC

△ NOTE

- Ensure coffee beans or pre-ground grinds are fresh.
- The grind size will affect the water flow rate through the coffee in the filter and the flavor of the espresso.
- Old coffee beans no matter the Grind Setting will have a fast extraction and will produce an under extracted tasting espresso.

9. Shot Volume Programming

The features Auto Shot Volumetric Control extracts just the right amount of espresso then automatically stops.

Possible setting range for different brew final dose:

ONE CUP Espresso = 25-60mL.

TWO CUP Espresso = 50-130mL.

At any point during espresso extraction, you can stop the pour by pressing the same button again.

• Preparing for Shot Programming

Step 1 - Check Water tank.

Ensure there is enough water in the tank.(NOT exceed the MAX line).

△ TIPS

For best espresso results, use filtered water & freshly roasted coffee beans.

5. Espresso Making Guide

△ NOTE

- Before insert the refill water tank,use the clean cloth to wipe off the water on the valve.
- When the water tank is pulled up,the water will flow out from the outlet at the bottom of the water tank, as it is a movable part. If you have pulled up several times and have not wipe the water immediately,it will accumulate more and more and ran to the bottom of the machine, maybe will leave the table full of water. It's not leaking.



Step 2 - Check Power Ensure that:

- The steam/water knob is in a horizontal position (off-position).
- Insert the Power Plug into a 120V AC power outlet & switch the power on.

Step 3 - Press the ON/OFF button to turn on the machine.

- The ON/OFF button will illuminate & pulse to indicate the Thermoblock is heating up.

- When 4 button's Light are all fully illuminated, the machine is in the READY state for all features.

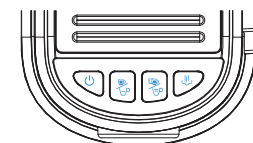

• One Cup - Shot Volume Program

Step 1 - Insert Single-cup filter Basket into the Portafilter & fill with coffee grinds then tamp. Place in the Group Head.

Step 2 - Dose with coffee grinds then tamp.

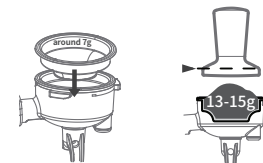

Step 3 - Insert Portafilter into the Group Head.

Step 4 - Press & hold the Single/short cup button and Double/long cup button for 3 seconds to enter into the user-defined mode.

- The Single/short cup button and Double/long cup button will flash to indicate it is in custom mode.

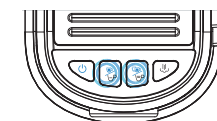
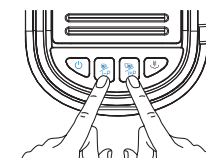

5. Espresso Making Guide

Step 5 - Press Single/short cup button one time, Espresso will start to pour.

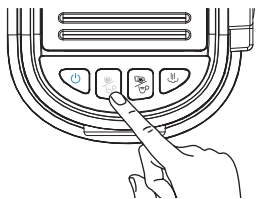

Step 6 - When you reach your desired 1 shot volume, press the Single/short cup button. The espresso pour will stop.

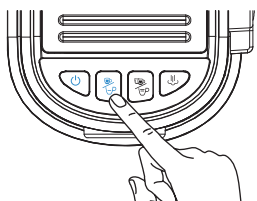

Step 7 - Press the Steam button within 15 seconds, ON/OFF button indicator will flash blue light for 3 times and the machine will have 3 beeps.

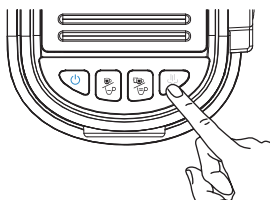

- The new ONE CUP espresso shot volume has been saved.
- The machine will return to the READY state.

NOTE

Press the ON/OFF button within 15 seconds. The machine will beep for one time and be back to ready mode without saving the new settings.

• Two Cup - Shot Volume Program

Step 1 - Insert Double-cup filter Basket into the Portafilter & fill with coffee grinds then tamp. Place in the Group Head.

Step 2 - Dose with coffee grinds then tamp.

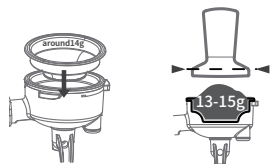

Step 3 - Insert Portafilter into the Group Head.

Step 4 - Press & hold the Single/short cup button and Double/long cup button for 3 seconds to enter into the user-defined mode.

- The Single/short cup button and Double/long cup button will flash to indicate it is in custom mode.

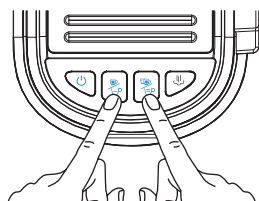

5. Espresso Making Guide

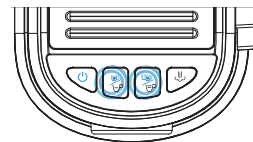

Step 5 - Press Double/short cup button one time, Espresso will start to pour.

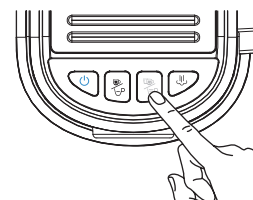

Step 6 - When you reach your desired 2 shot volume, press the Double/short cup button. The espresso pour will stop.

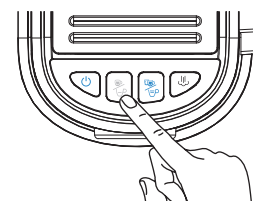

Step 7 - Press the Steam button within 15 seconds, ON/OFF button indicator will flash blue light for 3 times and the machine will have 3 beeps.

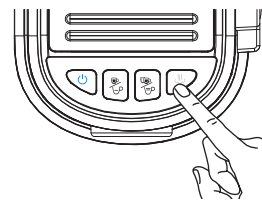

- The new TWO CUP espresso shot volume has been saved.
- The machine will return to the READY state.

NOTE

Press the ON/OFF button within 15 seconds. The machine will beep for one time and be back to ready mode without saving the new settings.

• Restore Default One Shot Shot Volumes

- Hold and press together the ON/OFF button and single cup button for 3 seconds and the machine will have 3 beeps. Then the default setting of brewing espresso will be restored and be back to ready mode.

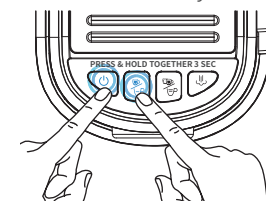

• Restore Default One & Two Shot Shot Volumes

- Step 1 - The machine is on and in the READY state.
- Step 2 - Hold and press together the ON/OFF button single cup button and double cup button for 3 seconds and the machine will have 3 beeps.
- The default setting of brewing espresso will be restored and be back to ready mode.

5. Espresso Making Guide

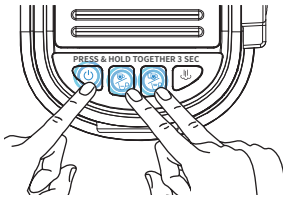

10. Manual Shot Volume

Manually control low pressure pre-infusion time and shot volume without reprogramming the preset shot volume.

Step 1 - Press and hold single cup button for three seconds, the single cup button will blink white light slowly. The extraction will enter low pressure pre-infusion.

- Extraction will continue at full pressure.

Step 2 - Press the single cup button again once the desired volume of espresso has been extracted.

11. Why No Coffee Pours

• If there is no water coming out of the water tank:

- Remove the silicone cap found at the base of the Water Tank.

- Fill up the water into the water tank and do not exceed the MAX line.

- Group Head may be blocked. To descale and more details, refer to "Cleaning Group Head" from "Care & Cleaning".

• If no water coming out of the group head without the mobile filter installed:

- If water is still not running through from Steam Wand. It can be caused by pressurized air in the boiler hindering the flow, refer to "Prime Espresso Machine" from "Before First Use of the coffee machine".

• If coffee grinds are tamped too hard:

- Tamp the grinds more lightly and press the grinds to the MAX line, you can refer to "6. Tamp Force" for more specific guides.

• If the powder is too much or over the MAX line:

Check whether the coffee powder is over the MAX line, if yes, then gently press the coffee powder to the MAX line.

For best results, ground dosage should remain consistent:

One Cup: 7g - about 1 Tbsp.

Two Cups: 14g - about 2 Tbsp.

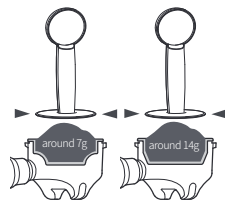

5. Espresso Making Guide

• If the single wall filter baskets is blocked:

- There is no coffee coming out of the portafilter, but remove the portafilter after making coffee and find that there is a lot of water or coffee left in filter baskets.

- It may take several incremental adjustments before you reach your optimum Grind Size. Dial in Grind Setting based on pouring time & taste, see Espresso Guide.

- When change to coarser powder to reach a better extraction, you can refer to "8. Extraction Guide" for more specific guides.

- To clean the filter baskets, you can refer to "Cleaning Filter Baskets" for more specific guides.

• If the machine cannot come out of water or the pressure gauge goes to the red area:

- Tamp the grinds more lightly and press the grinds to the MAX line, you can refer to "6. Tamp Force" for more specific guides.

- Do not use too fine powder, you can refer to "8. Extraction Guide" for more specific guides.

12. Why Coffee Pours Out In Drips

• If portafilter is not attached correctly, or has not been tightened sufficiently.

- Keep portafilter flat, aligned, inserted & properly turned into Group Head.

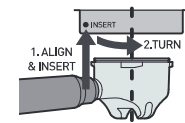

- Portafilter should be in the centre position.

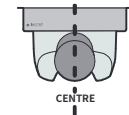

• If the coffee grinds are too much or over the MAX line:

Check whether the coffee powder is over the MAX line, if yes, then gently press the coffee powder to the MAX line.

For best results, ground dosage should remain consistent:

One Cup: 7g - about 1 Tbsp.

Two Cups: 14g - about 2 Tbsp.

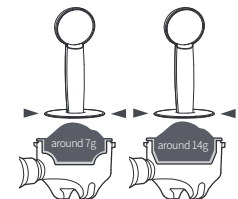

5. Espresso Making Guide

• If coffee grinds are too fine:

- Remove the Portafilter after making coffee and check whether there is a lot of water or coffee left in it.

It may take several incremental adjustments before you reach your optimum Grind Size. Dial in Grind Setting based on pouring time & taste, see Espresso Guide.

When change to coarser powder to reach a better extraction, you can refer to "8. Extraction Guide" for more specific guides.

• If coffee grinds are tamped too hard:

- Tamp the grinds more lightly and press the grinds to the MAX line, you can refer to "6.Tamp Force" for more specific guides.

• Group Head may be blocked.

Step 1 - Purge water through by press the Double/long cup button & water should start flowing from the Group Head.

- Allow water to run through until it stops.

- The machine will return to the READY state.

Step 2 - Wipe around the inside rim with a damp cloth & brush.

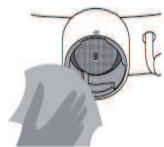

• The Single Wall Filter Baskets may be blocked.

Every Time

Wash after each use by rinsing them with warm water under the tap.

Regular Intervals

In warm soapy water using a mild detergent, rinse & dry.

• 2-3 Months

Step 1 - Soak the Filter Baskets overnight in the Milk Jug with warm water & add Espresso Machine Cleaning Descaler.

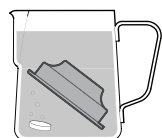

Step 2 - In the morning rinse the Milk Jug & Filter Basket (s) under running water ensuring all traces of the cleaning descaler have been removed.

Step 3 - Place a Filter Basket into Portafilter [without coffee grinds] and insert into Group Head.

Step 4 - Press Double/long cup button when the machine pass to ready condition

5. Espresso Making Guide

- Wait for a moment, Allow water to run through until it stops.

• Unblocking Filter Baskets

If the Single Wall Filter Basket becomes clogged with coffee grinds:

Step 1 - Place Filter Basket into Portafilter (without coffee) & insert into Group Head.

Step 2 - Press the Double/long cup button & water should start flowing from the Group Head.

- Allow water to run through until it stops.

- The machine will return to the READY state.

- Repeat if needed.

• If machine has dirty build up:

To descale and more details, refer to "Descaling: Group Head & Steam Wand".

the hole on the back of the machine, and press it down to be parallel to the top of the machine.

△ TIPS

- For best espresso results, use filtered water & freshly roasted coffee beans.

- As with NTC precision thermostats, the espresso extraction temperature is controlled at 197°F, while the milk frothing temperature is at 212°F.

△ NOTE

- Before insert the refill water tank, use the clean cloth to wipe off the water on the valve.

- If the temperature is too high to make espresso, the steam will splash from the portafilter and hot water will drip off. It will result in a small amount of coffee and a bad taste.

- When the water tank is pulled up, the water will flow out from the outlet at the bottom of the water tank, as it is a movable part. If you have pulled up several times and have not wipe the water immediately, it will accumulate more and more and ran to the bottom of the machine, maybe will leave the table full of water. It's not leaking.

5.3 Operation

1. Check Water

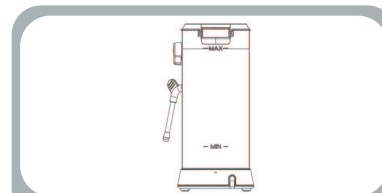

Fill water into the water tank NOT exceed the MAX line. Set up the water tank vertically and align the buckle to

5. Espresso Making Guide

2. Start Up

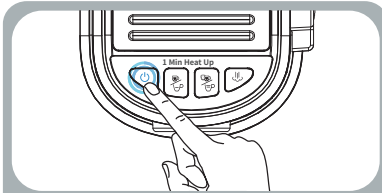

Insert the Power Plug. Press ON/OFF button to turn on, Power Light will illuminate & pulse = heating up.

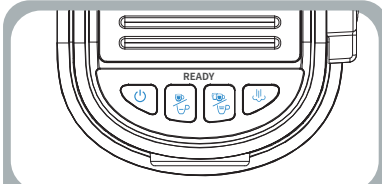

LIGHTS all fully illuminated = Espresso Machine ready to use.

3. Warm Cup by Hot Water

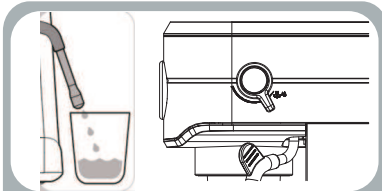

Place cup on counter top and position Steam Wand. Turn DIAL to "☕".

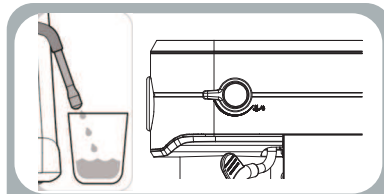

Half fill cup with hot water. Return DIAL to horizontal position (off-position).

△ NOTE

The machine is not equipped with any jug, please use your jug or coffee cup.

4. Select Filter Baskets

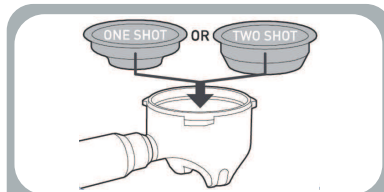

Select either:

- Single-cup filter Basket.
- Double-cup filter Basket.

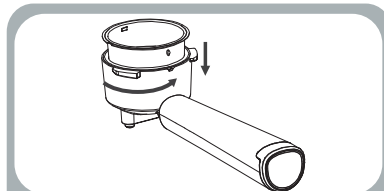

Place a filter basket inside the portafilter, make sure the tube on the Filter Baskets aligns with groove in the portafilter, then press down the filter basket firmly to portafilter.

5. Espresso Making Guide

5. Dose & Tamp

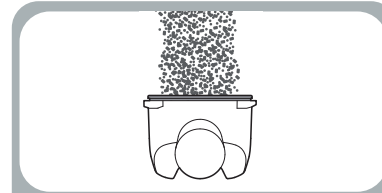

Dose the Filter Basket with grinds.

△ TIPS

- One spoon of fine grounds for single cup filter.
- Two spoons of fine grounds for double cups filter.

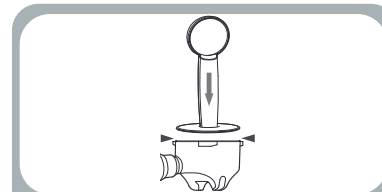

Evenly tamp (press) grinds to level indicated.

△ TIPS

To avoid leaking, coffee powder should be tamped BELOW the MAX line of portafilter.

△ NOTE

Do not press grounds with too much force. Use the tamper lightly to avoid clogging your machine. If grounds are too tightly packed, the water cannot flow through the portafilter and may cause blockage or leakage.

6. Wipe Excess Grinds

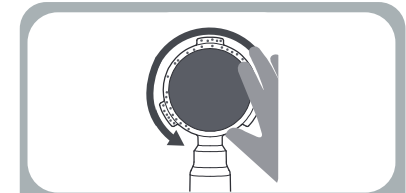

Wipe away any excess grinds to clear edges.

7. Insert Portafilter

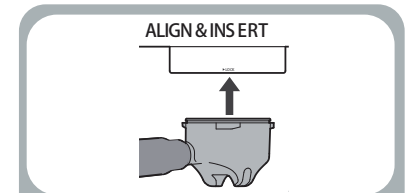

Faced up the portafilter, then installed in parallel to the machine from 'Insert' to 'Lock' in place. Portafilter should be in the center position. Otherwise the coffee will splash and leak from the gap of the connection position.

△ TIPS

Place a warm cup on the drip tray. If the cup is tall you can remove the drip tray cover and put the cup into the drip tray.

5. Espresso Making Guide

8. Insert Portafilter



Empty hot water from cup.

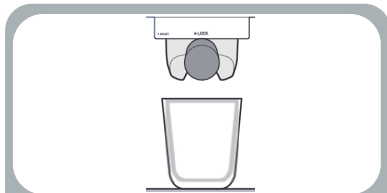

Position cup on Drip Tray, under Portafilter.

9. Espresso Extraction

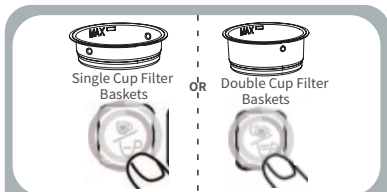

Press either Single/short cup button or Double/long cup button to start the espresso pour.

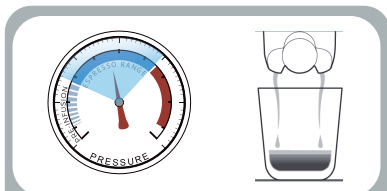

Extraction begins and will automatically stop. Now Crema is golden brown with a fine mousse texture.

△ TIPS

The portafilter should be removed after a while as the machine needs to relieve the pressure. Otherwise, the steam will splash out because of the strong pressure. Please remove in parallel. Because of high pressure, the water will fully penetrate into the coffee powder, it takes time for water to pass through and flow out of the coffee powder. So it is normal that the excess coffee will drip off.

△ NOTE

- When the machine starts to work, there will be some noise out from the machine as it is pumping the water with a high pressure.
- While during operation, if there is suddenly a loud noise and all four lights are blink blue light at the same time from the machine, which may be due to the water in the water tank is not enough for pumping. If so, please pay attention to the water volume and add water in time.

5. Espresso Making Guide

10. Remove Coffee Cake

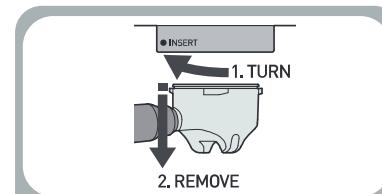

Wait 20 seconds to remove the portafilter from the Group Head after pouring to avoid any splashing or water discharge.

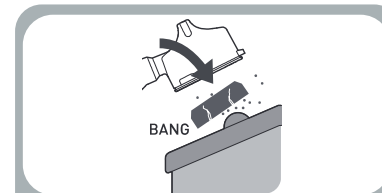

Remove spent (used) coffee cake from Portafilter.

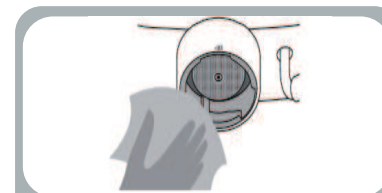

Wipe the powder outlet with a damp cloth.

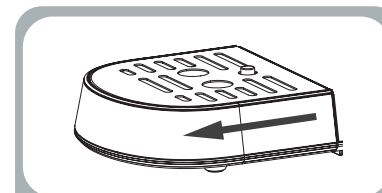

Check if the Drip Tray needs emptying.

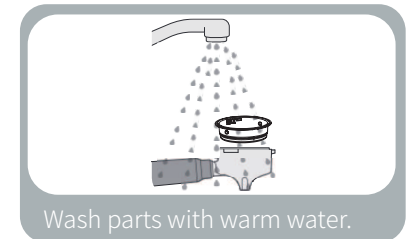

6. Make Milk Foam Guide

6.1 Brief Introduction

Milk frothing is the steaming of milk.

Key Elements of Textured Milk

The steam only heats the milk. The milk also needs to be aerated (add air) to create the micro-foam, and needs to be blended well together.

Milk that has been frothed correctly has been heated to between 140-149°F, and has a thick, rich micro-foam with a silky sheen. It's all about the temperature, positioning of the Steam Wand and when you move the Milk Jug.

6.2 Tips for Milk Frothing

General Tips for making good milk foaming:

1. Correct Temperature.

Press the Steam button when the machine is ready. When the steam button keeps white light fixed, the steam can be used.

△ TIPS

For better taste, we suggest releasing the water before frothing milk.

- Using correct temperature milk (41~45 °F).
- Using correct amount milk (100-150ml).
- Using correct size pitcher (around 350mL).
- Using the correct frothing way (show as below)

Detailed Tips for making good milk foaming:

1. Fill Milk Jug:

Add 100-150mL of cold milk around 4°C(40°F) into a chilled clean stainless steel Milk Jug. Fill to the bottom of the Milk Jug spout.

△ NOTE

The volume of milk will increase or 'stretch' during frothing, so don't overfill the Milk Jug.

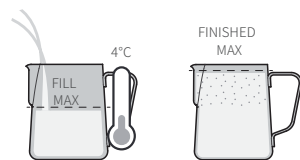

Use the 12 Oz (350ml) milk Jug.

2. Steam Warm Up:

Press the steam button when the machine is ready and it starts to blink white light slowly.

6. Make Milk Foam Guide

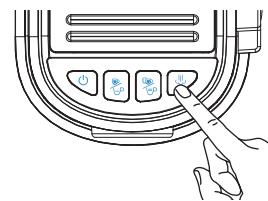

The steam button stops blinking and keeps white light fixed. It means the heating for steam is finished.

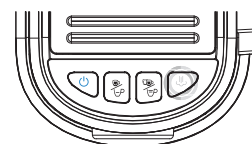

△ NOTE

For best milk frothing results every time, ensure steam has warmed up before frothing milk. Steam is ready when steam button light is fully ON. You will also hear the Pump start. Place a cup under the froth nozzle, then turn on the knob to " ۱۲/۱۵ ". Wait about a few seconds, there will be water coming out from the nozzle. Be careful of the hot steam. Then pour away the water of the cup.

3. Purge the steam wand of any water

With the steam wand positioned over the drip tray, activate the steam function by turning the steam/water knob to the " ۱۲/۱۵ "

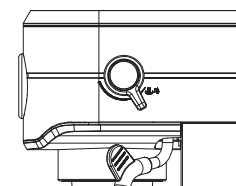

Once any water has been purged stop the steam by turning the Steam/water Knob to the horizontal position (off-position).

△ NOTE

Be careful not to get burned by the steam.

4. Position:

Place the Steam Wand Arm in the Milk ZZJug spout at the 12 o'clock position, with the Steam Wand Tip in the milk at the 3 o'clock position. Keep the Steam Wand Tip just under the surface of the milk. This will create a whirlpool action.

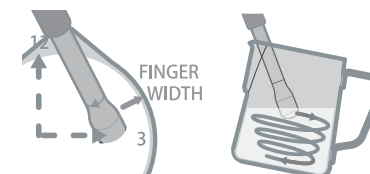

5. Sound:

How air is introduced to the milk determines the consistency of the foam. If large gulps of air are added to the milk, the foam will have large

6. Make Milk Foam Guide

bubbles. Introducing air to the milk in a controlled, gentle fashion indicated by a gentle hissing sound, will ensure the milk has fine aerated microfoam.

Barista Tip: Milk frothing Sounds

- Gurgling: Froth nozzle not deep enough, raise Milk Jug.
- Smooth Hissing: Just right for latte.
- Screeching: Froth nozzle too deep, lower Milk Jug.

6. Keeping Froth Nozzle Position:

As the steam heats & textures the milk, the milk will stretch causing the level of the milk in the Milk Jug to rise. As this happens follow the level of the milk by lowering the Milk Jug, keeping the Froth nozzle just below the surface.

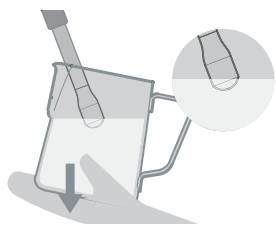

△ NOTE

Some adjustments to technique will be required when using non-dairy milk.

7. Amount of Foam:

Create the amount of microfoam you want. Cappuccinos traditionally have more microfoam than flat whites.

8. Immerse Froth nozzle :

After creating the desired amount of foam, immerse the Steam wand half depth way into the milk. This heats all the milk and pulls in milk instead of air. This ensures the milk & foam are blended together, making it denser & smoother.

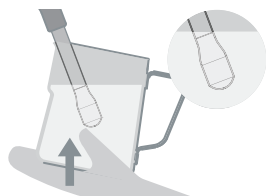

9. Correct Temperature:

An indication of reaching correct milk temperature is when the Milk Jug base can only be touched comfortably for approximately 3 seconds.

Barista Tip: Milk Temperature.

- Under: If not heated long enough, it will be warm with little texture.
- Optimum: between 140-149°F.
- Over: If heated for too long it will start to boil around 72°C and will have a burnt taste with all texture lost.

6. Make Milk Foam Guide

△ NOTE

Above recommendations might vary from one milk brand to another and depending on your taste preference.

10. After the Milk Frothing:

Milk temperature from 140-149°F is recommended for milk frothing, or you can increase or decrease the temperature to better suit your taste. Step 1 - Turn the steam/water knob to horizontal position (off-position).

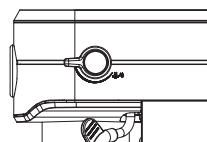

Step 2 - Press steam button to return stand by mode.

△ NOTE

If steam function is being used for more than 5 minutes, the ON/OFF button blinks red light quickly, and the steam button blinks white light quickly. Thus, reset steam/water knob to horizontal position (off-position) to stop it.

11. Tap & Swirl the Milk Jug :

Gently tapping the Milk Jug on the benchtop helps to release larger trapped air bubbles.

Swirling helps the milk & froth to combine for an even consistency & a silky appearance.

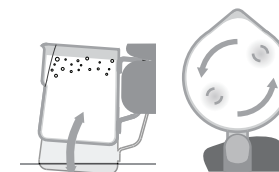

12. The Finishing Touches:

Pour from the Milk Jug into your cup in one steady motion.

△ NOTE

If there is no operation after 5 minutes, the machine will pass to sleep mode.

13. Purging the Steam Wand

After turning the steam/water knob to horizontal position (off-position), and removing the Milk Jug from the Steam Wand, place the Steam Wand over the Drip Tray and purge the Steam Wand to remove any milk that has been sucked up.

Press steam button to return stand by mode.

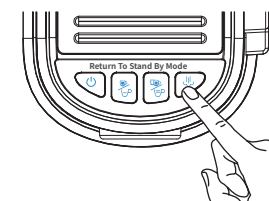

6. Make Milk Foam Guide

To purge turn the knob to the “☕/💧” position for a few seconds, then return the knob to the horizontal position (off-position).

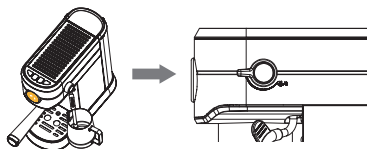

14. Wipe Steam wand :

Wipe the Steam wand Arm & froth nozzle with a clean damp cloth to remove any milk residue.



15. Make Espresso Immediately After Frothing Milk

- After making the froth milk, if you want to continue to brew coffee, you will find the high-temperature status by press the single cup button or double cup button.
- Then the machine will show you the single cup button and double cup button are blinking blue light quickly, and the ON/OFF button is blinking red light quickly.



- Start cooling the machine to make espresso.

Step 1 - Place a cup under the froth nozzle.

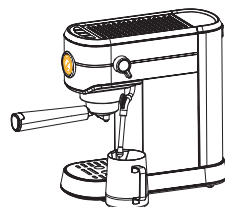

Step 2 - Turn the steam/water knob to the steam “☕/💧” position to release water out and make the machine to cool down.

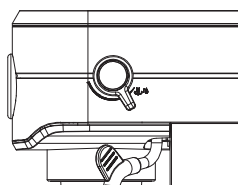

- Wait until 4 buttons switch on and blue light fixed. And the machine will return to the READY state.
- After that, turn the steam/water knob to horizontal position (off-position).
- Now, the machine is ready to brew coffee.

6. Make Milk Foam Guide

6.3 Operation

1. Check Water

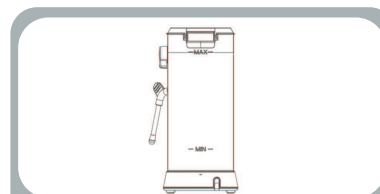

Fill water into the water tank NO Texceed the MAX line. Set up the water tank vertically and align the buckle to the hole on the back of the machine, and press it down to be parallel to the top of the machine.

⚠ TIPS

For best espresso results, use filtered water & freshly roasted coffee beans.

⚠ NOTE

- Before insert the refill water tank, use the clean cloth to wipe off the water on the valve.
- When the water tank is pulled up, the water will flow out from the outlet at the bottom of the water tank, as it is a movable part. If you have pulled up several times and have not wipe the water immediately, it will accumulate more and more and ran to the bottom of the machine, maybe will leave the table full of water. It's not leaking.

2. Start Up

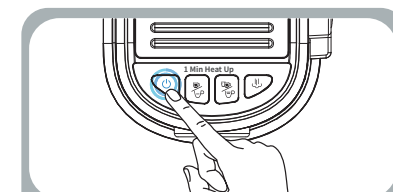

Insert the Power Plug. Press ON/ OFF button to turn on, Power Light will illuminate & pulse = heating up.

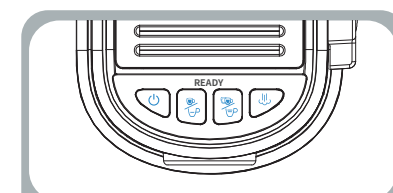

LIGHTS all fully illuminated = Espresso Machine ready to use.

3. Prep Milk Jug

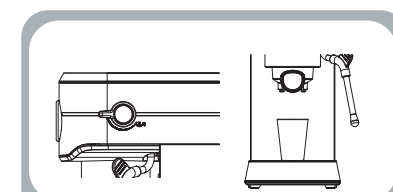

- Before making espresso, make sure the knob on the horizontal position (off-position).
- Make sure the froth nozzle is clean and not blocking.

6. Make Milk Foam Guide

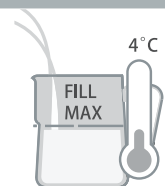

Fill 12 Oz(350ml) milk Jug. stainless steel Jug with cold milk just below the bottom of the spout. Recommended 100ml-150ml, 41-45°F milk.

4. Before frothing Milk

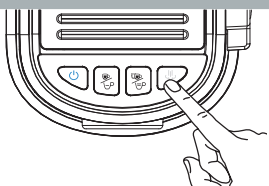

Press the steam button and start to blink white light slowly.

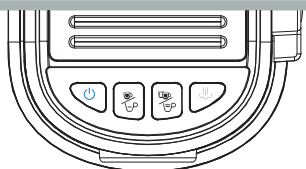

The steam button keeps white light fixed. It means the heating for steam is finished.

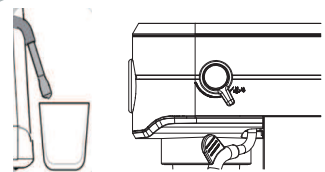

- Place cup on benchtop and position Steam Wand.
- Turn knob to " ↓ ↓ ↓ " .



Some water may come out of the Steam Wand.

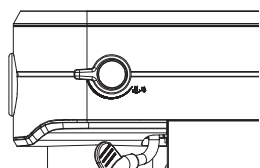

Pause steam by returning knob to horizontal position (off-position).

⚠ TIPS

For better taste, we suggest releasing the water before frothing milk.

⚠ NOTE

For best milk frothing results, ensure steam has first warmed up (STEAM LIGHT fully ON).

6. Make Milk Foam Guide

5. Position Steam Wand

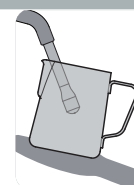

Insert Steam Wand Tip just below the surface of the milk.

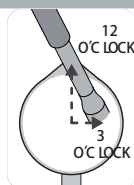

Steam Wand position:
The Froth nozzle is 1cm away from the jug wall.
- Arm at 12 o'clock.
- Tip at 3 o'clock.

6. Start frothing Milk

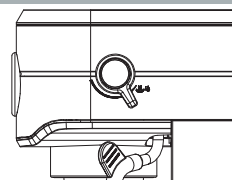

Turn knob back to " ↓ ↓ ↓ " to start frothing milk.



Frothing makes a smooth hissing noise.



Check milk is moving in a whirlpool action.

7. Milk frothing

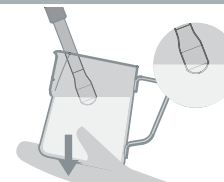

As milk level rises, lower Jug to keep Tip just below surface.

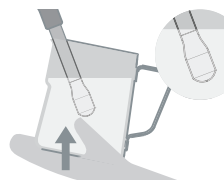

When desired microfoam achieved, immerse Steam Wand half way.

6. Make Milk Foam Guide

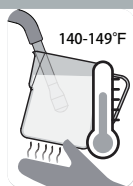

Milk ready when Milk Jug base is too hot to touch for 3 sec.

△ TIPS

After the milk jug base is too hot to touch for 3 sec. If you need more milk froth, you can continue to froth or stop according to your needs.

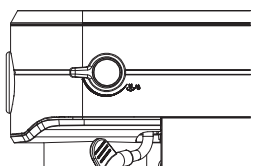

Return knob to horizontal position (off-position).

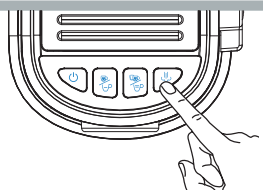

- Press the steam button and finish to blink white.
- Now Return to the READY state.



Remove Jug from Steam Wand.

△ NOTE

- If use steam function for more than 5 minutes, the ON/OFF button blink red light quickly, and the steam button blink white light quickly. Thus, reset steam/water knob to horizontal position (off-position) to stop it.

- During the milk frothing, if there is suddenly a noise and all four lights are blink blue light at the same time. It will come out with small steam. Please check whether the water is enough and add water in time. The milk will be empty from jug and make it again. When the water left the water tank is going to finish, it will produce a louder noise for pumping. After adding water, it will operate as usual.

8. Milk Finishing Touches

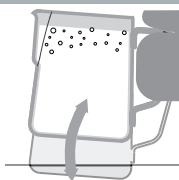

Tap Jug to release larger air bubbles.

6. Make Milk Foam Guide



Swirl Jug to blend milk and create a silky texture.

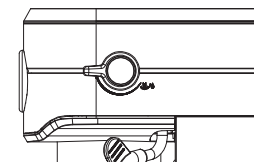

Return knob to the horizontal position (off-position).



Use damp cloth to pull out the stainless sleeve then clean the outside steam wand.



Pour milk in one steady motion.

9. Purge & Clean Steam Wand

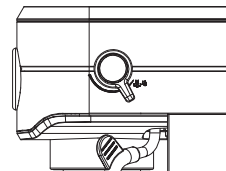

Turn knob to "☺☺" for 1-2 sec.

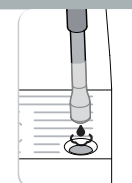

Release some steam for 4-5s to clean the froth nozzle from the milk residue & prevent future blockage.

△ TIPS

To keep optimum Steam Wand performance, always purge & clean the Steam Wand after frothing milk.

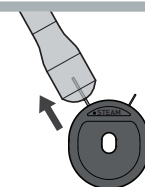

If steam wand becomes clogged, insert the steam wand tip pin to the froth nozzle hole and remove the obstruction. (The machine needs to be turned off, it is best to unplug the power plug and operate in the cold state), then run steam again for 10-15s.

6. Make Milk Foam Guide

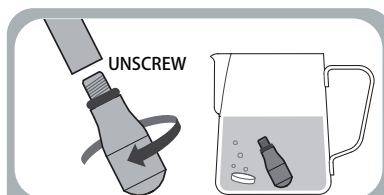

If steam wand remains blocked, unscrew the froth nozzle and soak in the milk jug with warm water & espresso machine descaler for deeply clean.

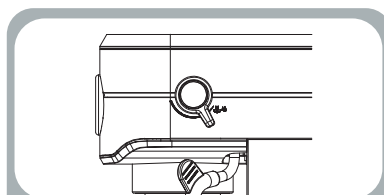

Turn the steam/water knob to the steam “☁️/💧” position to release water out and make the machine to cool down.

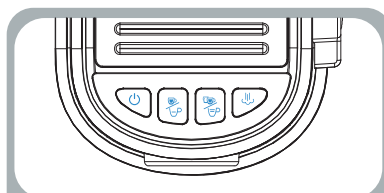

Return to the READY state.

10. Thermoblock Auto Purge

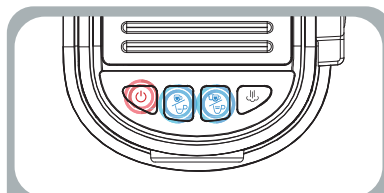

When cooling to espresso temp, single cup button and double cup button are blinking blue light quickly, and the ON/OFF button is blinking red light quickly. Keep Drip Tray in place.

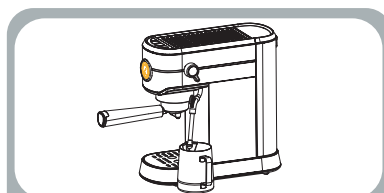

Place a cup under the froth nozzle.

7. Hot water Guide

7.1 Brief Introduction

Pours more than 5 min then automatically stops. Use for long black coffee, hot drinks such as tea, instant soups and to warm cups prior to making espresso.

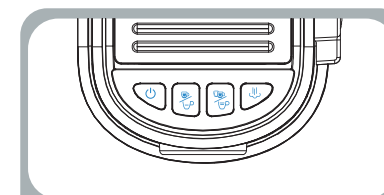

LIGHTS all fully illuminated = Espresso Machine ready to use.

7.2 Operation

1. Check Water

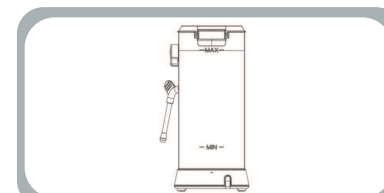

⚠️ TIPS

For best espresso results, use filtered water & freshly roasted coffee beans.

2. Start Up

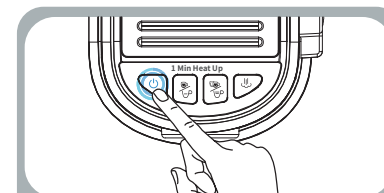

Press ON/OFF button to turn on, Power Light will illuminate & pulse = heating up.

3. Hot Water

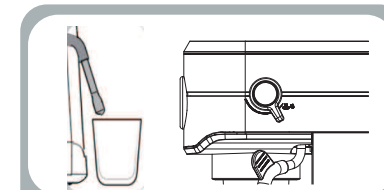

- Place cup on benchtop and position Steam Wand.
- Turn knob back to “☁️/💧” to start Hot Water.



Hot water will pour from the hot water outlet and can be used for making Americanos and pre-heating cups.

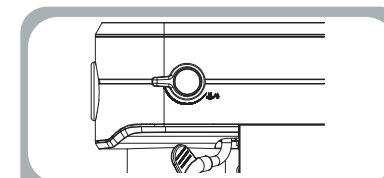

To stop the hot water, return knob to horizontal position (off-position).

8. Automatic Sleep Mode Function Guide

- If there is no any operation after 5 minutes, the machine will beep for a while and all button's light will be turned off and the machine will pass to sleep mode.

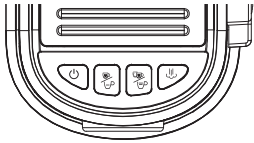

Step 1 - To reactivate the machine, press ON/OFF button, the ON/OFF button start to blink blue light slowly, other buttons do not light up.

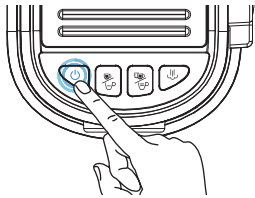

- When the machine has reached the correct operating temperature, the ON/OFF button light will stop flashing and all button lights on the control panel will illuminate, the machine come into ready condition.

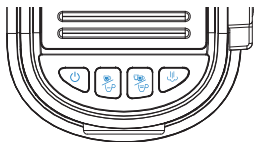

Step 2 - Long press the ON/OFF button for 2 seconds, the machine will switch off.

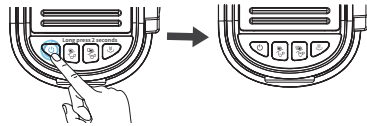

△ NOTE

After you make the milk foam, if there is no operation after 5 minutes, the machine will pass to sleep mode. All button's light will be turned off. Press the ON/OFF button, the machine will pass to ready condition without warm up and all the lights switch on. Because the machine's temperature is too high. And it is not suitable to make coffee. In this case, please refer to the section of " Make Espresso Immediately After Frothing Milk " to lower the inner the temperature down.

9. Water Shortage Mode Function Guide

- During the brew function, if the Water Tank is out of water, the machine's 4 buttons light (ON/OFF button, single cup button, double cup button, steam button) will blink blue light together and the machine will automatically stop to brew.

△ NOTE

After 1 minute without any operation, the blue light of the ON/OFF button is always on, and the lights of other buttons are off.

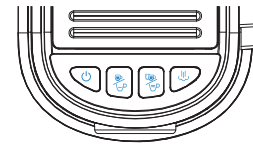

Step 1 - Press any button to return to the READY state. Then refill the Water Tank with clean water immediately.

△ NOTE

Due to the water shortage in the portafilter, the machine will have high temperature and high pressure, so we recommend you to follow the two steps:

Step 2 - Firstly, remove the portafilter and clean the coffee powder and don't use the same coffee powder again.

10. Care & Cleaning

The espresso making process involves extracting oils out of ground coffee. Deposits of grinds & oils build up over time, affecting the taste of the coffee & operation of the machine.

Purging water through the Group Head & Steam Wand, before & after making each coffee, is the easiest way to keep your machine clean.

△ IMPORTANT

Below parts are NON-Dishwasher Safe parts:
- Water Tank.
- Portafilter.
- Drip tray.

Cleaning Drip Tray

• When Required

Empty if the red Water Level Indicator appears through the Stainless Steel Grill, otherwise water will overflow.

• Weekly

Clean the Drip Tray and Grill with warm water and a little non-abrasive washing up liquid, rinse and dry.

△ NOTE

Over time it is normal for the inside of the Drip Tray to be stained by the oils in the coffee grinds.

Cleaning Warming Plate & Exterior

Wipe over the machine with a damp cloth and wipe dry. Do not use alkaline cleaning agents, abrasives or metal scourers, as these will scratch the exterior surface.

△ CAUTION

Do not immerse the machine in water.

Cleaning Portafilter & Filter Basket

• Every Time

Wash after each use by rinsing them with warm water under the tap.

• Regular Intervals

In warm soapy water using a mild detergent, rinse & dry.

Cleaning Group Head

• Every Time

Run water through before making an espresso.

• Weekly

Step 1 - Purge water through by press the Double/long cup button & water should start flowing from the Group Head.

- Allow water to run through until it stops.

10. Care & Cleaning

- The machine will return to the READY state.

Step 2 - Wipe around the inside rim with a damp cloth & brush.



Cleaning Filter Baskets

• 2-3 Months

Step 1 - Soak the Filter Baskets overnight in the Milk Jug with warm water & add Espresso Machine Cleaning Descaler.

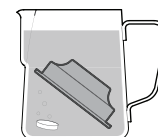

Step 2 - In the morning rinse the Milk Jug & Filter Basket (s) under running water ensuring all traces of the cleaning descaler have been removed.

Step 3 - Place a Filter Basket into Portafilter [without coffee grinds] and insert into Group Head.

Step 4 - Press Double/long cup button when the machine pass to ready condition.

- Wait for a moment, allow water to run through until it stops.

• Unblocking Filter Baskets

If the Single Wall Filter Basket becomes clogged with coffee grinds:

Step 1 - Place Filter Basket into Portafilter (without coffee) & insert into Group Head.

Step 2 - Press the Double/long cup button & water should start flowing from the Group Head.

- Allow water to run through until it stops.

- The machine will return to the READY state.

- Repeat if needed.

Cleaning Steam Wand

• Every Time

Step 1 - After frothing milk, purge the Steam wand by turning the steam/water knob to "↓/▲" for just 3-4 seconds.

Step 2 - Wipe the Steam wand with a damp cloth.

• 2-3 Months

Step 1 - Soak the Steam wand overnight in the Milk Jug with warm water & add Espresso Machine Cleaning Descaler.

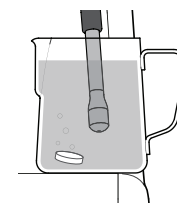

10. Care & Cleaning

Step 2 - In the morning remove the Milk Jug and rinse ensuring that all traces of the solution have been removed.

Step 3 - Wipe Steam wand with a damp cloth ensuring that all traces of the cleaning descaler have been removed.

- Run Steam through the Steam wand for 3-4 seconds.

• Unblocking Steam Wand

If the Froth nozzle becomes clogged with milk residue:

Step 1 - Turn off the machine, it is best to unplug the power plug and operate in the cold state.

Step 2 - Insert the Steam Wand Tip Pin up the Froth nozzle hole and remove.

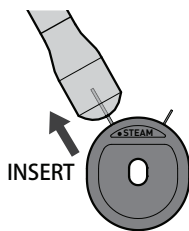

- Run Steam through the Steam wand for 3-4 seconds.

• Steam wand Remains Blocked

Step 1 - Unscrew the Froth nozzle and soak overnight in the Milk Jug with warm water & Espresso Machine Cleaning Descaler.

△ NOTE

The temperature of the steam wand is very high during use, and it is easy to burn your hands. Please turn off the machine and clean in a cold state.



Step 2 - In the morning rinse the Milk Jug & Froth nozzle under running water ensuring all traces of the cleaning descaler have been removed.

Step 3 - Use the Steam Wand Tip Pin to clean the Steam Tip.

Step 4 - Ensure transparent O-ring is present & undamaged.

Step 5 - Screw the Steam Wand Tip back into the Steam Wand Arm.

- Run Steam through the Steam wand for 3-4 seconds.

Group Head Rubber Seal

A rubber seal is located in the Group Head and creates a seal against the Filter Basket when making an espresso.

△ IMPORTANT

When your espresso machine is not being used, we recommend that you do not leave the Portafilter inserted into the Group Head, as this will reduce the life of the seal.

10. Care & Cleaning

△ NOTE

This machine has no user serviceable parts. Any servicing beyond that described in the Cleaning Section should be performed by an Authorized Service Representative only.

11. Descaling: Group Head & Steam Wand

After continued use, your espresso machine may develop a build-up of mineral deposits, and therefore require occasional 'descaling'.

We recommend descaling your machine every 4-6 months, although this period will depend on the hardness of water and frequency of use.

Descaling warning will be shown when the machine has cumulatively worked for 500 cycles. At that moment, the power button and steam button light are blue and blink and beep simultaneously about 10s.

Press steam button to cancel the descaling warning, all 4 buttons' light will keep blue fixed. Then machine come into ready condition.

△ NOTE

Descaling warning will be shown every 10 cycles after cancel the descaling warning as the machine haven't finished the descaling yet.

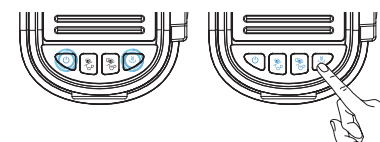

Descaling Solution

You have 3 options:

a. One espresso machine descaling tablet.

or

b. Liquid descaler.

or

c. White vinegar & warm water.

You also can use powder descalers or others to clean your machine as you like. For specific cleaning methods, please refer to the instructions provided by your descaler provider.

Descaling Program

The Descaling Program takes approximately 10 minutes to complete.

11. Descaling: Group Head & Steam Wand

⚠ IMPORTANT

If the Descaling Cycle is not completed or stopped part way through any of the Descaling Steps, then you will need to start the Descaling Cycle again from the beginning.

Preparing for Descaling

• Fill Water Tank with Solution

a. Fill Water tank with 4 cups of warm water add Espresso Machine Descaling Descaler. Allow tablet to fully dissolve. Allow solution to mix thoroughly.

or
b. In an empty Water tank add half a cap full of Liquid Descaler. Fill Water tank with 4 cups of warm water. Allow solution to mix thoroughly.

or
c. In an empty Water tank add 1½ tablespoons of white vinegar. Fill Water tank with 4 Cups of warm water. Allow solution to mix thoroughly.

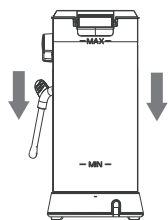

• Place Containers

- Place a 4 Cups container under Group Head and another 4 Cups container under the Steam Wand.



• Power

Ensure that:

- The steam/water knob is in a horizontal position (off-position).
- Insert the Power Plug into a 120V AC power outlet & switch the power on.
- Press the ON/OFF button to turn on the machine.
- The ON/OFF button will illuminate & pulse to indicate the Thermoblock is heating up.
- When 4 button's Light are all fully illuminated, the machine is in the READY state.

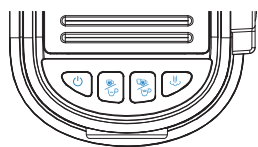

• Access the Descaling Cycle

Step 1 - Simultaneously press & hold power button and steam button for 3s, then 4 button's light keep blue fixed.

11. Descaling: Group Head & Steam Wand

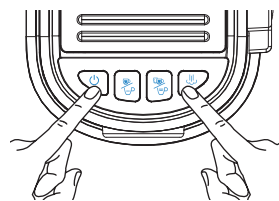

⚠ IMPORTANT

If Descaling Step 1 is not started within 5 minutes after entering the Descaling Cycle, the machine will exit the Descaling Cycle and go back to the READY state.

⚠ IMPORTANT

The Descaling Cycle can be exited at any point by pressing the any button.

1. Steam Wand Descaling

Step 1 - Move the cup under the Steam wand.

Step 2 - To start the Descaling Program and turn the steam/water knob to the steam “☽/☾” position.

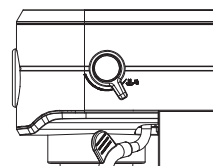

- The Pump will start and hot water will run from the Steam Wand. Over a 2 minute period the Pump will make different noises.

- The Single/short cup button and Double/long cup button blink blue light slowly.

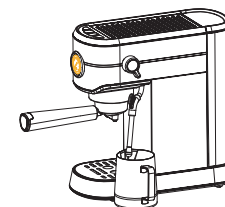

Step 3 - The Steam wand will always flow out citric acid until you turn the water/steam knob to horizontal position (off-position).

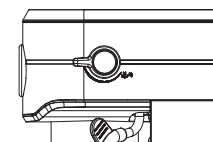

- Move to "2. Group Head Descaling".

⚠ IMPORTANT

In-between each of the Descaling Steps there is a maximum of 5 minutes allowed to start the next step before the Descaling Program will exit.

2. Group Head Descaling

Step 1 - Press and hold single cup button for three seconds, the single cup button will blink white light slowly.

11. Descaling: Group Head & Steam Wand

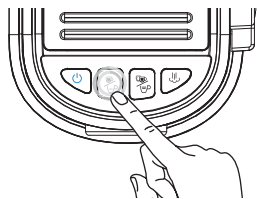

The Pump will start and hot water will run from the Group Head. Over a 2 minute period the Pump will make different noises.

Step 2 - Press the single cup button again.

The hot water has stopped being released from the Group Head, this step has finished.

- Move to "Preparing for Purge".

3. Preparing for Purge

The Steam Wand and Group Head now need to be purged clean with fresh water to remove descaling solution.

Step 1 - Rinse Water tank

Remove the Water tank & rinse thoroughly under running water, ensuring that all traces of the descaling solution have been removed.

Step 2 - Fill Water tank

Fill the Water tank to the 'MAX' line with clean water and replace.

Step 3 - Empty Containers

Empty water from the containers and replace.

- Move to "3. Steam Wand Purge".

4. Steam Wand Purge

Step 1 - To continue turn the steam/water knob to the steam “☁️/💧” position.

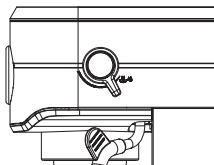

The Single/short cup button and Double/long cup button will flash combination.

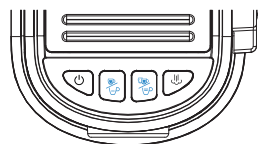

The Pump will start and hot water will run from the Steam Wand. Over a 2 minute period the Pump will make different noises.

Step 2 - When the steam wand is cleaned by hot water, turn the water/steam knob to horizontal position (off-position).

When the hot water has stopped being released from the Steam Wand, this step has finished.

the machine will return to the READY state.

- Move to "4. Group Head Purge".

11. Descaling: Group Head & Steam Wand

5. Group Head Purge

Step 1 - Press and hold single cup button for three seconds, the single cup button will blink white light slowly.

The Pump will start and hot water will run from the Group Head. Over a 2 minute period the Pump will make different noises.

Step 2 - Press the single cup button again.

- The hot water has stopped being released from the Group Head, the Descaling Program has finished.

• Complete

- The Descaling Cycle is complete. The machine will return to the READY state.

- Empty water from the containers.

12. Troubleshooting Guide - Espresso Machine

Problem	Possible Cause	Way To Check	What To Do
The coffee maker cannot work.	The power outlet is not plugged well.	Press the power button but it doesn't work, check if the plug is plugged in and if the plug is loose.	Plug the power cord into a wall outlet correctly, if the appliance still does not work, please contact with the authorized service facility for repairing.
1.Portafilter comes off during espresso pour.	Portafilter is not attached correctly, or has not been tightened sufficiently.	Portafilter is not in the center position in "Lock".	Ensure all three tabs of the Portafilter are fully inserted into the Group Head, & rotated to the center position.
	The powder is too much or over the MAX line.	Please check that the powder is the MAX line of the filter baskets.	Press the coffee powder lightly to the max line.
2.Espresso squirts out of the Group Head during pour.	Coffee grind is too fine.	The machine does not have water or the pressure gauge goes to the red area.	Change to a coarser grind.
	Coffee grinds tamped too hard.		Tamp the grinds more lightly.
	Top edge of filter is not free of coffee grinds.	The filter basket is not placed correctly on the portafilter.	Clean around the top edge of the filter and wipe the Group Head clean.
3.Espresso trickles down the side of the Portafilter.	The Group Head is dirty.	Check if the Group Head is blocked by powder.	Wipe with a damp cloth. Clean the seal including the bayonet corner areas with a brush to remove grinds.
	Group Head rubber seal is damaged or worn.	Check if the rubber of the group head is damaged or loose.	Contact Gevi Customer Care.

12. Troubleshooting Guide - Espresso Machine

Problem	Possible Cause	Way To Check	What To Do	
No coffee pours.	The silicone cap in the water tank has not been removed.	Check if the silicone cap stayed at the base of the Water Tank.	Remove the silicone cap found at the base of the Water Tank.	
	No water in the Water Tank.	All four lights are blink blue light at the same time.	Please fill up the water into the water tank but pay attention that the water to fill must not to exceed the MAX line.	
	Group Head may be blocked.	Check if the Group Head is blocked by powder.	To descale and more details, refer to "Descaling: Group Head & Steam Wand".	
		Pressurized air in the boiler is hindering the flow.	When the coffee is operated without a portafilter installed, the machine does not dispense water.	If water is still not running through from Steam Wand. It can be caused by pressurized air in the boiler hindering the flow, refer to "Prime Espresso Machine" from "Before First Use of the coffee machine".
		Grinds are too fine.	The machine cannot come out of water or the pressure gauge goes to the red area.	Change to a coarser grind.
		Coffee tamped too hard.		Tamp the grinds more lightly.
		The Single Wall Filter Baskets may be blocked.	There is no coffee coming out of the portafilter, but remove the portafilter after making coffee and find that there is a lot of water or coffee left in filter baskets.	When the filter is blocked, the Portafilter cannot be installed, To clean the filter baskets, you can refer to "Cleaning Filter Baskets" for more specific guides.

12. Troubleshooting Guide - Espresso Machine

Problem	Possible Cause	Way To Check	What To Do	
Coffee pours out in drips.	Portafilter is not attached correctly, or has not been tightened sufficiently.	Coffee leaking from the side of the portafilter.	Re-install the portafilter correctly.	
	The powder is too much or over the MAX line.		Press the coffee powder lightly to the max line.	
	Grinds are too fine.	Remove the portafilter after making the coffee and find that there is a lot of water or coffee left in it.	Change to a coarser grind.	
	Coffee tamped too hard.		Tamp the grinds more lightly.	
	Group Head may be blocked.	Check if the Group Head is blocked by powder.	To descale and more details, refer to "Descaling: Group Head & Steam Wand".	
	The Single Wall Filter Baskets may be blocked.	There is no coffee coming out of the portafilter, but remove the portafilter after making coffee and find that there is a lot of water or coffee left in filter baskets.		When the filter is blocked, the Portafilter cannot be installed, To clean the filter baskets, you can refer to "Cleaning Filter Baskets" for more specific guides.
	Machine has dirty build up.	The machine does not work smoothly, or the coffee comes out with a bad taste.		To descale and more details, refer to "Descaling: Group Head & Steam Wand".
The machine makes weak coffee.	The coffee beans are inappropriate.	The color of the coffee coming out is light, and the flow rate is too fast.	Use blended coffee beans.	
	The size of coffee grinds is too coarse.		Use fine coffee grinds.	
	The amount of coffee grinds is inappropriate.	Please check that the powder is the MAX line of the filter baskets.		Not enough coffee grinds, use more grinds.



12. Troubleshooting Guide - Espresso Machine

Problem	Possible Cause	Way To Check	What To Do
The machine makes weak coffee.	The coffee grinds are tamped too tight.	The pointer of the pressure gauge when making coffee is not within the coffee temperature range.	Ensure coffee is tamped evenly and check there is nothing obstructing the pouring spouts.
	Not an appropriate temperature for brewing coffee.	Check if the 4 buttons' Lights are fully illuminated.	Make sure the temperature is correct(89-95°C /192-203°F).
	The espresso amount is inappropriate.	Too much water for coffee.	30mL per cup.
Espresso does not have any Crema (Under Extracted).	Beans are old or pre-ground grinds are dry.	The coffee comes out with insufficient or no grease.	Use fresh beans and grinds. Be sure to store pre-ground grinds in an airtight container.
	Grinds not compacted enough.		Tamp more firmly.
	Grinds too coarse.		Use a finer grind coffee.
	Use 1 cup filter to brew 2 cup of coffee.		Select the appropriate filter to extract the corresponding cup amount.
Uneven cup filling.	Uneven tamping or obstruction in the pouring spouts.	There are bumps on the surface of the coffee powder in the portafilter that has finished making the coffee.	Ensure coffee is tamped evenly and check there is nothing obstructing the pouring spouts.
Used Espresso puck is wet.	Single Wall Filter Baskets can keep the espresso puck wet.	There is no coffee coming out of the portafilter, but remove the portafilter after making coffee and find that there is a lot of water or coffee left in filter baskets.	Keep Portafilter in Group Head until milk frothing is finished. This will give more time for the water to dissipate.

12. Troubleshooting Guide - Espresso Machine

Problem	Possible Cause	Way To Check	What To Do
Espresso tastes burnt.	Type of coffee being used.	whether to use freshly ground coffee beans.	Try different brands of coffee.
Coffee is too cold.	The cups were not warmed before extraction.	The temperature of the cup is too low.	Warm the cup before brew.
Pump makes an unusually noise.	No water in the Water Tank.	All four lights are blink blue light at the same time.	Please fill up the water into the water tank but pay attention that the water to fill must not to exceed the MAX line.
	Water tank not correctly positioned.	There is no coffee coming out of the portafilter.	Place the Water tank firmly into the back of the unit.
	Red Plug from the packaging may still be inserted.	Check if the silicone cap stayed at the base of the Water Tank.	Remove the silicone cap found at the base of the Water Tank.
Acid (vinegar) taste exists in Espresso coffee.	No proper clean after cleaning the mineral deposits.	The machine has not been cleaned for a long time.	Clean the coffee maker per the instructions "Descaling: Group Head & Steam Wand" for several times.
	The coffee powder is stored in a hot, wet place for a long time. The coffee powder turns bad.		Please use fresh coffee powder, or store unused coffee powder in a cool, dry place. After opening a package of coffee powder, reseal it tightly and store it in a refrigerator to maintain its freshness.
Water leaks from the bottom of coffee maker.	There is much water in the drip tray.	The drip tray is overflowing.	Please clean the drip tray.
	The sealing ring of the water inlet hole of the machine base is deformed.	Water tank not installed correct.	Please contact with the authorized service facility for repair.

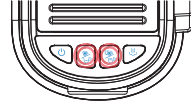

12. Troubleshooting Guide - Espresso Machine

Problem	Possible Cause	Way To Check	What To Do
Water leaks from the bottom of coffee maker.	Malfunction of the coffee maker.	Press the ON/OFF button After the machine is plugged in, the Power Light does not illuminate & pulse.	Please contact with the authorized service facility for repair.
	When the water tank is pulled up after use, it is normal that there will be water left on the desk.	there will be water left on the desk.	As the water outlet at the bottom of the water tank is a movable part and it is not leaking.
All four lights are blink blue light at the same time. 	There is not enough water in the water tank.	All four lights are blink blue light at the same time.	Please fill up the water into the water tank but pay attention that the water to fill must not to exceed the MAX line.
Single / double cup coffee light flashes alternately and alarms, always beeping. 	NTC disconnect or short circuit.	Single / double cup coffee light flashes alternately and alarms, always beeping.	Please contact with the authorized service facility for repair.
ON/OFF button and steam button blink blue lights and beep simultaneously for 10 seconds. 	Need to clean and descaling.	ON/OFF button and steam button blink blue lights and beep simultaneously for 10 seconds.	To descale and more details, refer to "Descaling: Group Head & Steam Wand".

13. Troubleshooting Guide - Steam Wand

Problem	Possible Cause	Way To Check	What To Do
No steam from the Steam Wand.	No water in the Water Tank.	Check the tank for water.	Fill tank with water. Run Hot Water through the Steam Wand to ensure water flows.
	Steam Wand Tip is blocked.	There is water when making coffee, but no steam or water from the froth nozzle when making steam.	To clean and more details, refer to "Care & Cleaning".
Not enough froth when frothing.	Milk may not be fresh.	The milk foam effect is poor.	Ensure the milk being used is fresh.
	Milk temperature is too warm.	The milk foam effect is poor.	Ensure you start frothing with milk that is around 39°F.
	Type of Milk Jug being used.	Using an unprofessional milk jug.	For best frothing results use a chilled Stainless Steel Milk Jug.
	Milk has been boiled.	The milk foam effect is poor.	Start again with fresh, chilled milk. Heat till the Milk Jug can only be held for approximately 3 seconds, 140-149°F.
	The milk is making bubbles rather than micro-foam.	The milk foam effect is poor.	Ensure the Steam Wand Tip is positioned correctly. It should be just below the surface of the milk. Tap the Milk Jug on the benchtop when finished to release larger trapped air bubbles.
	Milk is not taking in enough air.	The milk foam effect is poor.	Keep the Steam Wand Tip just under the surface of the milk. This will help to introduce air to the milk to create micro-foam.

13. Troubleshooting Guide - Steam Wand

Problem	Possible Cause	Way To Check	What To Do
Not enough froth when frothing.	The quantity of jug is inappropriate.	The milk foam effect is poor.	Using 100-150ml milk for each frothing.
	The temperature of milk is inappropriate.	The milk foam effect is poor.	The milk temperature is about 41-45°F.
	The size of jug is inappropriate.	The milk foam is poor.	Use a correct size of jug(350ml).
The ON/OFF button keep blue light fixed, the other button's light blink blue and beep at the same time.	The machine is on while the steam/water knob is not fixed in the off position.		The ON/OFF button keep blue light fixed, the other button's light blink blue and beep at the same time.
ON/OFF button blink red light quickly, and the steam button blink white light quickly.	Use steam function for more than 5 minutes.		Reset steam/water knob to horizontal position (off-position).
	Use hot water function for more than 5 minutes.		
The ON/OFF button blink red light, and single cup button and double cup button blink blue light.	The temperature inside the machine is too high, because making coffee immediately after steam.		The ON/OFF button blink red light, and single cup button and double cup button blink blue light.

13. Troubleshooting Guide - Steam Wand

Problem	Possible Cause	Way To Check	What To Do
<p>The ON/OFF button blink red light, and single cup button and double cup button blink blue light.</p> 	<p>The temperature inside the machine is too high, because making coffee immediately after making steam.</p>	<p>The ON/OFF button blink red light, and single cup button and double cup button blink blue light.</p>	<p>Natural cooling: Do nothing and let the machine stand still and wait for about half an hour.</p>

If this guide does not solve your question, contact Gevi Customer Care.

14. Warranty



This Gevi product is covered by a 12-month replacement or repair warranty after the order is issued under normal use, and we will provide customer service to answer technical questions even after 12 months.

In order to make a claim under our warranty, you must have the original proof of purchasing documentation for the product, including but not limited to Order Number and QR Code, and present it when requested. This guarantee is valid for the original retail purchaser from the date of initial retail purchase and is not transferable.

Upon receipt of your claim, Gevi will seek to resolve your difficulties. Should your product develop any defect within 12 months of purchase because of faulty materials or workmanship, we will repair or replace this product or any component of the product, at our discretion. Replacement will be made with a refurbished product or component. Refurbished parts may be used to repair the product.

Our replacement or repair warranty only applies where a defect arises as a result of faulty material or workmanship during the warranty period. Your warranty does not cover misuse or negligent handling (including

damage caused by failing to use the product in accordance with this instruction booklet), accidental damage, normal wear and tear, or lack of maintenance. Do Not attempt to repair or adjust any electrical or mechanical functions on this product. Doing so will void this guarantee.

Your warranty does not :

- * cover freight or any other costs incurred in making a claim, consumable items, accessories that by their nature and limited lifespan require periodic renewal (such as filters and seals) or any consequential loss or damage; or

- * cover damage caused by :

- power surges, power dips, voltage supply problems, or use of the product on incorrect voltage;
- servicing or modification of the product other than by Gevi or an authorized Gevi service center;
- use of the product with other accessories, attachments, product supplies, parts or devices that do not confirm to Gevi specifications; or

14. Warranty

- exposure of the product to abnormally corrosive condition.

* extend beyond 3 months if the product is used in commercial, industrial, educational or rental applications.

If your warranty claim is not accepted, we will inform you and if requested to do so by you, repair the product provided you pay the usual charges for such repair. You will also be responsible for all freight and other costs.

Transport: When sending the machine, use the original packing materials, the inner and outer cartons or use approximately 2” of bubble wrap and secure the machine properly. Any damage in transit is NOT covered by this warranty.

Should your product require repair or service after the warranty period, contact Gevi after-sales team.

15. Coffees To Try

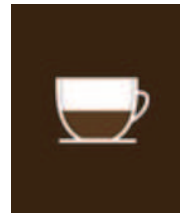

Espresso (Short Black)

Espresso is a concentrated, full bodied coffee with a stable layer of crema on top. An espresso is the foundation of all cafe coffee.

- Espresso glass (3 oz).
- Single or double shot of espresso (1-2 oz).

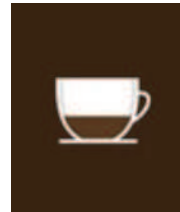

Ristretto

A ristretto is an extremely short espresso, distinguished by its intense flavor, aftertaste and its thin crema on top.

- Espresso cup (1 oz).
- Half a single shot of espresso (0.5 oz).

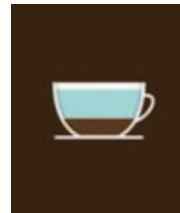

Long Black (Americano)

A standard espresso with hot water added. The hot water is added first so that the crema is maintained.

- Cup (6 oz).
- Hot Water (to preference).
- Single or double shot of espresso (1-2 oz).



Con Panna

Con Panna, Italian for "with cream", made up of an espresso topped with lightly whipped cream. It can also be dusted with cinnamon or chocolate.

- Cup (6 oz).
- Single or double shot of espresso (1-2 oz).
- Lightly whipped cream - dusted cinnamon.



Macchiato

Macchiato, Italian for 'to stain or mark'. Traditionally served as a standard espresso with a dash of cold or frothed milk & a small dollop of foam into the middle of the crema.

- Espresso glass (3 oz).
- Single or double shot of espresso (1-2 oz).
- Dash of cold or frothed milk & small dollop of foam.

15. Coffees To Try

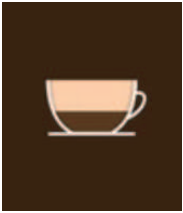

Flat White

An espresso with frothed milk & a thin layer of foam milk on top. The wider cup will create the slim layer of foam, the signature of the flat white.

- Wide cup (6 oz).
- Single or double shot of espresso (1-2 oz).
- Frothed milk & foam.

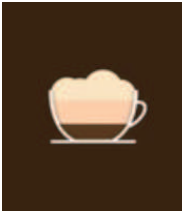

Latte

An espresso with frothed milk & a finger width layer of foam milk on top. The narrower cup will create the thicker layer of foam.

- Glass or Cup (7 oz).
- Single or double shot of espresso (1-2 oz).
- Frothed milk & foam.



Cappuccino

An espresso with 1/3 steamed frothed milk, topped with 1/3 creamy foam & a dusting of chocolate.

- Cup (6-8 oz).
- Single or double shot of espresso (1-2 oz).
- 1/3 frothed milk, 1/3 foam - dusted with chocolate.



Mocha

Made in a similar way to a cappuccino but with the addition of chocolate. Simply stir the chocolate into the espresso prior to adding the steamed milk & foam.

- Cup or tall glass (6-8 oz).
- Single or double shot of espresso (1-2 oz).
- Chocolate Syrup (to preference).
- 1/3 Frothed milk, 1/3 foam.



Babyccino

Steamed frothed milk with a layer of foamed milk. It can also be dusted with chocolate.

- Small cup (3 oz).
- No shot of espresso.
- Frothed milk & foam - dusted with chocolate.